

## **GB** Forced draught gas burners

Modulating operation

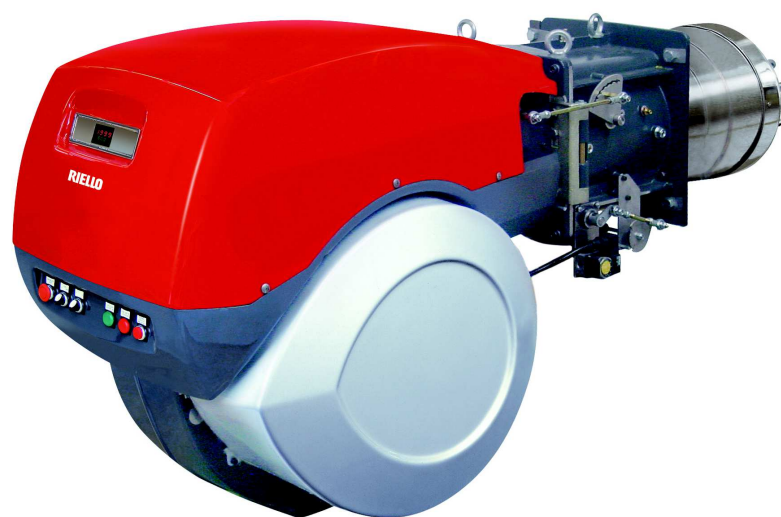

CODE	MODEL	TYPE
3898340 - 3898350	RS 300/EV BLU	849 T2
3898442 - 3898452	RS 400/EV BLU	850 T2
3899142 - 3899152	RS 500/EV BLU	856 T2
20040547	RS 650/EV BLU	1123 T2
3911080 - 3911090	RS 800/EV BLU	887 T2



**Translation of the original instructions**

<b>1</b>	<b>Declarations</b>	<b>3</b>
<b>2</b>	<b>Information and general warnings</b>	<b>4</b>
2.1	Information about the instruction manual	4
2.1.1	Introduction	4
2.1.2	General dangers	4
2.1.3	Other symbols	4
2.1.4	Delivery of the system and the instruction manual	5
2.2	Guarantee and responsibility	5
<b>3</b>	<b>Safety and prevention</b>	<b>6</b>
3.1	Introduction	6
3.2	Personnel training	6
<b>4</b>	<b>Technical description of the burner</b>	<b>7</b>
4.1	Burner designation	7
4.2	Models available	7
4.3	Technical data	8
4.4	Electrical data	8
4.5	Burner categories - Countries of destination	9
4.6	Maximum dimensions	9
4.7	Firing rates	10
4.8	Test boiler	11
4.9	Burner equipment	11
4.10	Burner description	12
4.11	Electrical panel description	13
4.12	Control box for the air/fuel ratio (LMV52...)	14
4.13	Servomotor (SQM48.4...)	16
<b>5</b>	<b>Installation</b>	<b>17</b>
5.1	Notes on safety for the installation	17
5.2	Handling	17
5.3	Preliminary checks	17
5.4	Operating position	18
5.5	Removal of the locking screws from the shutter	18
5.6	Preparing the boiler	18
5.6.1	Boring the boiler plate	18
5.6.2	Blast tube length	18
5.7	Securing the burner to the boiler	19
5.8	Access to head internal part	19
5.9	Probe-electrode position	19
5.10	Combustion head adjustment	20
5.11	Gas feeding	21
5.11.1	Gas feeding line	21
5.11.2	Gas train	22
5.11.3	Gas train installation	22
5.11.4	Gas pressure	23
5.12	Electrical wiring	24
5.12.1	Supply cables and external connections passage	24
<b>6</b>	<b>Start-up, calibration and operation of the burner</b>	<b>25</b>
6.1	Notes on safety for the first start-up	25
6.2	Adjustments prior to ignition	25
6.3	Burner start-up	25
6.4	Burner ignition	25
6.5	Combustion air adjustment	26

6.5.1	Air adjustment for maximum output .....	26
6.5.2	Air/fuel adjustment and output modulation system .....	26
6.6	Pressure switch adjustment .....	27
6.6.1	Air pressure switch - check CO.....	27
6.6.2	Maximum gas pressure switch.....	27
6.6.3	Minimum gas pressure switch.....	27
6.6.4	PVP pressure switch kit .....	27
<b>7</b>	<b>Maintenance .....</b>	<b>28</b>
7.1	Notes on safety for the maintenance .....	28
7.2	Maintenance programme .....	28
7.2.1	Maintenance frequency.....	28
7.2.2	Checking and cleaning.....	28
7.3	Opening the burner .....	29
7.4	Closing the burner.....	29
<b>8</b>	<b>Faults - Probable causes - Solutions .....</b>	<b>30</b>
<b>A</b>	<b>Appendix - Accessories .....</b>	<b>31</b>
<b>B</b>	<b>Appendix - Electrical panel layout.....</b>	<b>33</b>

**1 Declarations**

**Declaration of conformity in accordance with ISO / IEC 17050-1**

Manufacturer:	RIELLO S.p.A.		
Address:	Via Pilade Riello, 7 37045 Legnago (VR)		
Product:	Forced draught gas burners		
Model:	RS 300/EV BLU RS 400/EV BLU RS 500/EV BLU RS 650/EV BLU RS 800/EV BLU		
These products are in compliance with the following Technical Standards:			
EN 676			
EN 12100			
and according to the European Directives:			
GAD	2009/142/EC		Gas Devices Directive
MD	2006/42/EC		Machine Directive
LVD	2006/95/EC		Low Voltage Directive
EMC	2004/108/EC		Electromagnetic Compatibility
Such products are marked as follows:			
	EC-0085BO0341	RS 300-400/EV BLU	
	EC-0085BS0382	RS 500/EV BLU	
	EC-0085BT0337	RS 650/EV BLU	
	EC-0085BT0337	RS 800/EV BLU	

The quality is guaranteed by a quality and management system certified in accordance with UNI EN ISO 9001.

**Manufacturer's Declaration**

RIELLO S.p.A. declares that the following products comply with the NOx emission limits specified by German standard "1. BIm-SchV revision 26.01.2010".

Product	Type	Model	Output
Forced draught gas burners	849T2	RS 300/EV BLU	500 - 3800 kW
	850T2	RS 400/EV BLU	800 - 4550 kW
	856T2	RS 500/EV BLU	1000 - 5170 kW
	1123T2	RS 650/EV BLU	1400 - 6500kW
	887T2	RS 800/EV BLU	1200 - 8100 kW

Legnago, 21.05.2015

Executive General Manager  
RIELLO S.p.A. - Burner Department

Mr. U. Ferretti

Research & Development Director  
RIELLO S.p.A. - Burner Department

Mr. F. Comencini

**2 Information and general warnings**

**2.1 Information about the instruction manual**

**2.1.1 Introduction**

The instruction manual supplied with the burner:

- is an integral and essential part of the product and must not be separated from it; it must therefore be kept carefully for any necessary consultation and must accompany the burner even if it is transferred to another owner or user, or to another system. If the manual is lost or damaged, another copy must be requested from the Technical Assistance Service of the area;
- is designed for use by qualified personnel;
- offers important indications and instructions relating to the installation safety, start-up, use and maintenance of the burner.

**Symbols used in the manual**

In some parts of the manual you will see triangular DANGER signs. Pay great attention to these, as they indicate a situation of potential danger.

**2.1.2 General dangers**

The **dangers** can be of **3 levels**, as indicated below.



**Maximum danger level!**  
This symbol indicates operations which, if not carried out correctly, cause serious injury, death or long-term health risks.



This symbol indicates operations which, if not carried out correctly, may cause serious injury, death or long-term health risks.



This symbol indicates operations which, if not carried out correctly, may cause damage to the machine and/or injury to people.

**2.1.3 Other symbols**



**DANGER: LIVE COMPONENTS**  
This symbol indicates operations which, if not carried out correctly, lead to electric shocks with lethal consequences.



**DANGER: FLAMMABLE MATERIAL**  
This symbol indicates the presence of flammable materials.



**DANGER: BURNING**  
This symbol indicates the risks of burns due to high temperatures.



**DANGER: CRUSHING OF LIMBS**  
This symbol indicates the presence of moving parts: danger of crushing of limbs.



**WARNING: MOVING PARTS**  
This symbol indicates that you must keep limbs away from moving mechanical parts; danger of crushing.



**DANGER: EXPLOSION**  
This symbol signals places where an explosive atmosphere is present. An explosive atmosphere is defined as a mixture of dangerous substances with air, under atmospheric conditions, in the form of gases, vapours, mist or dust in which, after ignition has occurred, combustion spreads to the entire unburned mixture.



**PERSONAL PROTECTION EQUIPMENT**  
These symbols indicate the equipment that must be worn and kept by the operator for protection against threats against safety and/or health while at work.



**MOUNT CASING**  
This symbol indicates that it is mandatory to mount casing again after maintenance, cleaning or checks.



**ENVIRONMENTAL PROTECTION**  
This symbol gives indications for the use of the machine with respect for the environment.



**IMPORTANT INFORMATION**  
This symbol indicates important information that you must bear in mind.

- This symbol indicates a list.

**Abbreviations used**

Ch.	Chapter
Fig.	Figure
Page	Page
Sec.	Section
Tab.	Table

**2.1.4 Delivery of the system and the instruction manual**

When the system is delivered, it is important that:

- the instruction manual is delivered to the user by the system manufacturer, with the recommendation to keep it in the room where the heat generator is to be installed.
- The instruction manual shows:
  - the serial number of the burner;

.....

- the address and telephone number of the nearest Assistance Centre.

.....

.....

.....

- The system supplier must carefully inform the user about:
  - the use of the system;
  - any further tests that may be required before activating the system;
  - maintenance, and the need to have the system checked at least once a year by a representative of the manufacturer or another specialised technician.
 To ensure a periodic check, the manufacturer recommends the drawing up of a Maintenance Contract.

**2.2 Guarantee and responsibility**

The manufacturer guarantees its new products from the installation date, in accordance with the regulations in force and/or the sales contract. At the moment of the first start-up, check that the burner is integral and complete.



**WARNING**

Failure to observe the information given in this manual, operating negligence, incorrect installation and carrying out of non authorised modifications will result in the annulment by the manufacturer of the guarantee that it supplies with the burner.

In particular, the rights to the guarantee and the responsibility will no longer be valid, in the event of damage to things or injury to people, if such damage/injury was due to any of the following causes:

- incorrect installation, start-up, use and maintenance of the burner;
- improper, incorrect or unreasonable use of the burner;
- intervention of unqualified personnel;
- carrying out of unauthorised modifications on the equipment;
- use of the burner with safety devices that are faulty, incorrectly applied and/or not working;
- installation of untested supplementary components on the burner;
- powering of the burner with unsuitable fuels;
- faults in the fuel supply system;
- use of the burner even following an error and/or an irregularity;
- repairs and/or overhauls incorrectly carried out;
- modification of the combustion chamber with inserts that prevent the regular development of the structurally established flame;
- insufficient and inappropriate surveillance and care of those burner components most likely to be subject to wear and tear;
- the use of non-original components, including spare parts, kits, accessories and optional;
- force majeure.

**The manufacturer furthermore declines any and every responsibility for the failure to observe the contents of this manual.**

### 3 Safety and prevention

#### 3.1 Introduction

The burners have been designed and built in compliance with current regulations and directives, applying the known technical rules of safety and envisaging all the potential danger situations.

It is necessary, however, to bear in mind that the imprudent and clumsy use of the equipment may lead to situations of death risk for the user or third parties, as well as the damaging of the burner or other items. Inattention, thoughtlessness and excessive confidence often cause accidents; the same applies to tiredness and sleepiness.

It is a good idea to remember the following:

- The burner must only be used as expressly described. Any other use should be considered improper and therefore dangerous.

In particular:

it can be applied to boilers operating with water, steam, diathermic oil, and to other users expressly named by the manufacturer;

the type and pressure of the fuel, the voltage and frequency of the electrical power supply, the minimum and maximum deliveries for which the burner has been regulated, the pressurisation of the combustion chamber, the dimensions of the combustion chamber and the room temperature must all be within the values indicated in the instruction manual.

- Modification of the burner to alter its performance and destinations is not allowed.
- The burner must be used in exemplary technical safety conditions. Any disturbances that could compromise safety must be quickly eliminated.
- Opening or tampering with the burner components is not allowed, apart from the parts requiring maintenance.
- Only those parts envisaged by the manufacturer can be replaced.



The manufacturer guarantees safety and proper functioning only if all burner components are intact and positioned correctly.

#### 3.2 Personnel training

The user is the person, body or company that has acquired the machine and intends to use it for the specific purpose. He is responsible for the machine and for the training of the people working around it.

The user:

- undertakes to entrust the machine exclusively to suitably trained and qualified personnel;
- undertakes to inform his personnel in a suitable way about the application and observance of the safety instructions. With that aim, he undertakes to ensure that everyone knows the use and safety instructions for his own duties;
- Personnel must observe all the danger and caution indications shown on the machine.
- Personnel must not carry out, on their own initiative, operations or interventions that are not within their province.
- Personnel must inform their superiors of every problem or dangerous situation that may arise.
- The assembly of parts of other makes, or any modifications, can alter the characteristics of the machine and hence compromise operating safety. The manufacturer therefore declines any and every responsibility for any damage that may be caused by the use of non-original parts.

In addition:



- the user must take all the measures necessary to prevent unauthorised people gaining access to the machine;
- the user must inform the manufacturer if faults or malfunctioning of the accident prevention systems are noticed, along with any presumed danger situation.
- Personnel must always use the personal protective equipment envisaged by legislation and follow the indications given in this manual.



**4 Technical description of the burner**

**4.1 Burner designation**

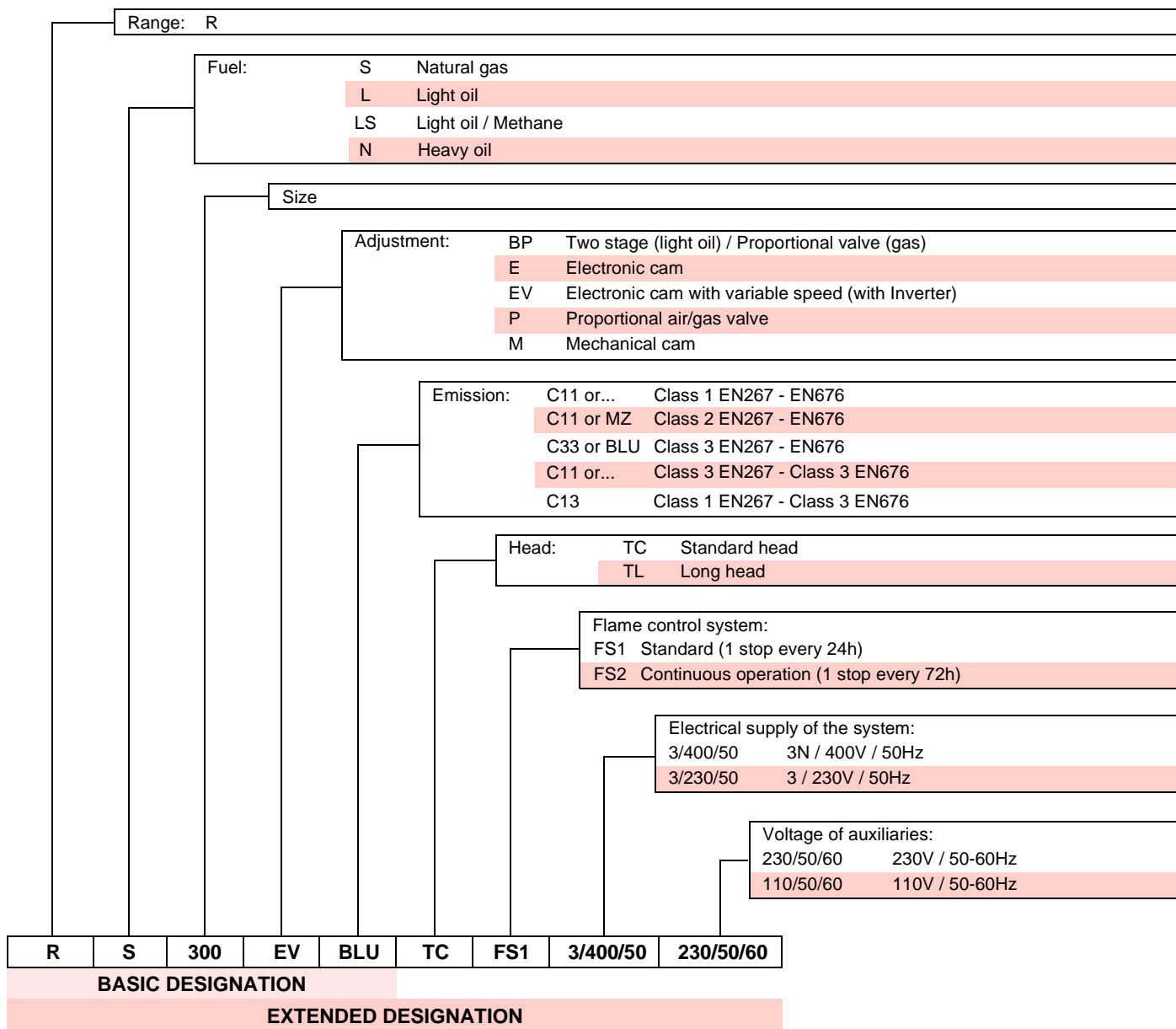

**4.2 Models available**

Designation	Voltage	Start-up	Code
RS 300/EV BLU	3/230-400/50	Direct/Inverter	3898340 - 3898350
RS 400/EV BLU	3/400/50	Direct/Inverter	3898442 - 3898452
RS 500/EV BLU	3/400/50	Direct/Inverter	3899142 - 3899152
RS 650/EV BLU	3/400/50	Direct/Inverter	20040547
RS 800/EV BLU	3/400/50	Direct/Inverter	3911080 - 3911090

Tab. A

### 4.3 Technical data

Model			RS 300/EV BLU	RS 400/EV BLU	RS 500/EV BLU	RS 650/EV BLU	RS 800/EV BLU
Type			849 T2	850 T2	856 T2	1123 T2	887 T2
Output (1)	min-max	kW	500/1350 ÷ 3800	800/1840 ÷ 4550	1000/2500÷5170	1410/3020÷6500	1200/3500÷8100
Fuels			Natural gas: G20 (methane gas) - G21 - G22 - G23 - G25				
Gas pressure at max. output (2) - Gas: G20/G25		mbar	23.3/32.7	34.3/40.2	37.6/56.1	44.8/64.4	45.5/81.2
Operation			Continuous / Intermittent				
Standard applications			Boilers: water, steam, diathermic oil				
Ambient temperature		°C	0 - 50				
Combustion air temperature		°C max	60				
Noise levels (3)							
Sound pressure		dB(A)	82	85	88	90.1	88.1
Sound power			-	-	-	104.3	102.5
Burner weight		Kg	230	240	250	300	300

Tab. B

(1) Reference conditions: Ambient temperature 20°C - Gas temperature 15°C - Barometric pressure 1013 mbar - Altitude 0 m a.s.l.

(2) Pressure at the test point of the pressure switch (20)(Fig. 4) with zero pressure in the combustion chamber and at maximum burner output.

(3) Sound pressure measured in manufacturer's combustion laboratory, with burner operating on test boiler and at maximum rated output.

### 4.4 Electrical data

Model			RS 300/EV BLU	RS 400/EV BLU	RS 500/EV BLU	RS 650/EV BLU	RS 800/EV BLU
Main electrical supply			3N ~ 400V +/-10% 50 Hz				
Fan motor IE2	rpm		2900	2900	2900	2900	2900
	V		230/400	400/690	400/690	400/690	400/690
	kW		4.5	7.5	9.2	18.5	22
	A		15/8.7	13.8/8	16.9/9.7	35.7/20.6	41.8/24.2
Ignition transformer		V1 - V2 I1 - I2	230 V - 1 x 8 kV 1 A - 20 mA				
Absorbed electrical power		kW max	5.9	9.2	10.8	20.8	24.5
Protection level			IP 54				

Tab. C

Model			RS 400/EV BLU	RS 500/EV BLU	RS 650/EV BLU	RS 800/EV BLU	
Main electrical supply			3N ~ 400V +/-10% 50 Hz				
Fan motor IE3	rpm		2920	2880	2880	2880	
	V		400/690	400/690	400/690	400/690	
	kW		7.5	9.2	18.5	22	
	A		14/8.1	16.8/9.7	32.2/18.6	38.2/22.3	
Ignition transformer		V1 - V2 I1 - I2	230 V - 1 x 8 kV 1 A - 20 mA				
Absorbed electrical power		kW max	8,8	10,6	20,5	24	
Protection level			IP 54				

Tab. D

**4.5 Burner categories - Countries of destination**

Gas category	Destination country
I <sub>2</sub> H	SE - FI - AT - GR - DK - ES - GB - IT - IE - PT - IS - CH - NO
I <sub>2</sub> ELL	DE
I <sub>2</sub> L	NL
I <sub>2</sub> Er	FR
I <sub>2</sub> E(R)B	BE
I <sub>2</sub> E	LU - PL

Tab. E

**4.6 Maximum dimensions**

The maximum dimensions of the burner are shown in Fig. 1. Bear in mind that inspection of the combustion head requires the burner to be opened and the rear part turned on the hinge.

The maximum dimensions of the open burner are indicated by the L and R positions.

The I position is reference for the refractory thickness of the boiler door.

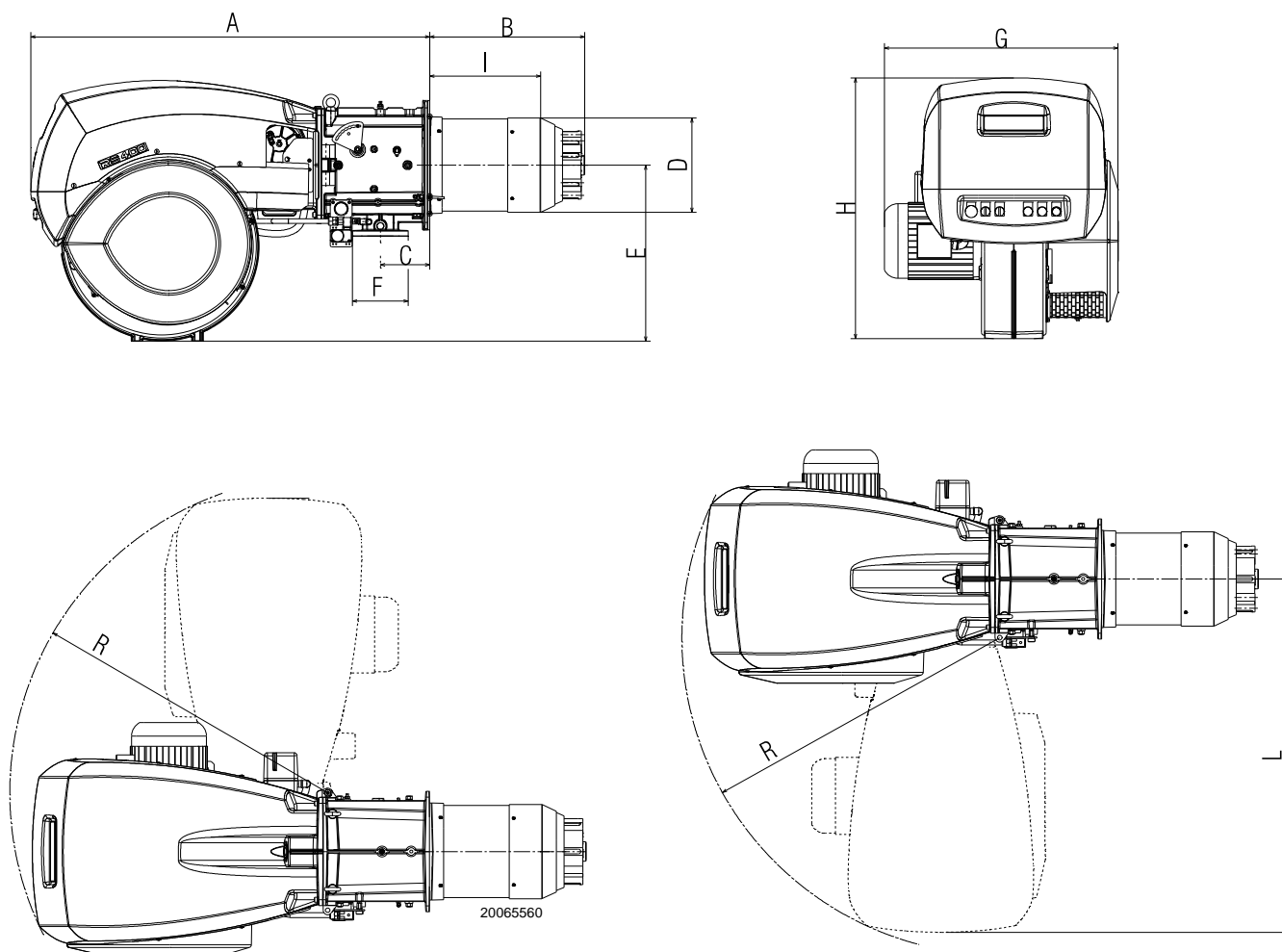

Fig. 1

mm	A	B	C	D	E	F	G	H	I	L	R
RS 300/EV BLU	1325	521	164	313	588	DN65	720	867	373	1175	1055
RS 400/EV BLU	1325	521	164	313	588	DN65	775	867	373	1175	1055
RS 500/EV BLU	1325	521	164	370	588	DN65	775	867	357	1175	1055
RS 650/EV BLU	1325	549	164	363	588	DN65	940	867	397	1175	1055
RS 800/EV BLU	1325	582	164	363	588	DN80	940	867	418	1175	1055

Tab. F

4.7 Firing rates

The **MAXIMUM OUTPUT** is chosen from within the diagram area (Fig. 2).

The **MINIMUM OUTPUT** must not be lower than the minimum limit of the diagram:



The firing rate value (Fig. 2) has been obtained considering an ambient temperature of 20C, an atmospheric pressure of 1013 mbar (approx. 0 m a.s.l.), and with the combustion head adjusted as shown on page 20.

Model	kW
RS 300/EV BLU	500
RS 400/EV BLU	800
RS 500/EV BLU	1000
RS 650/EV BLU	1400
RS 800/EV BLU	1200

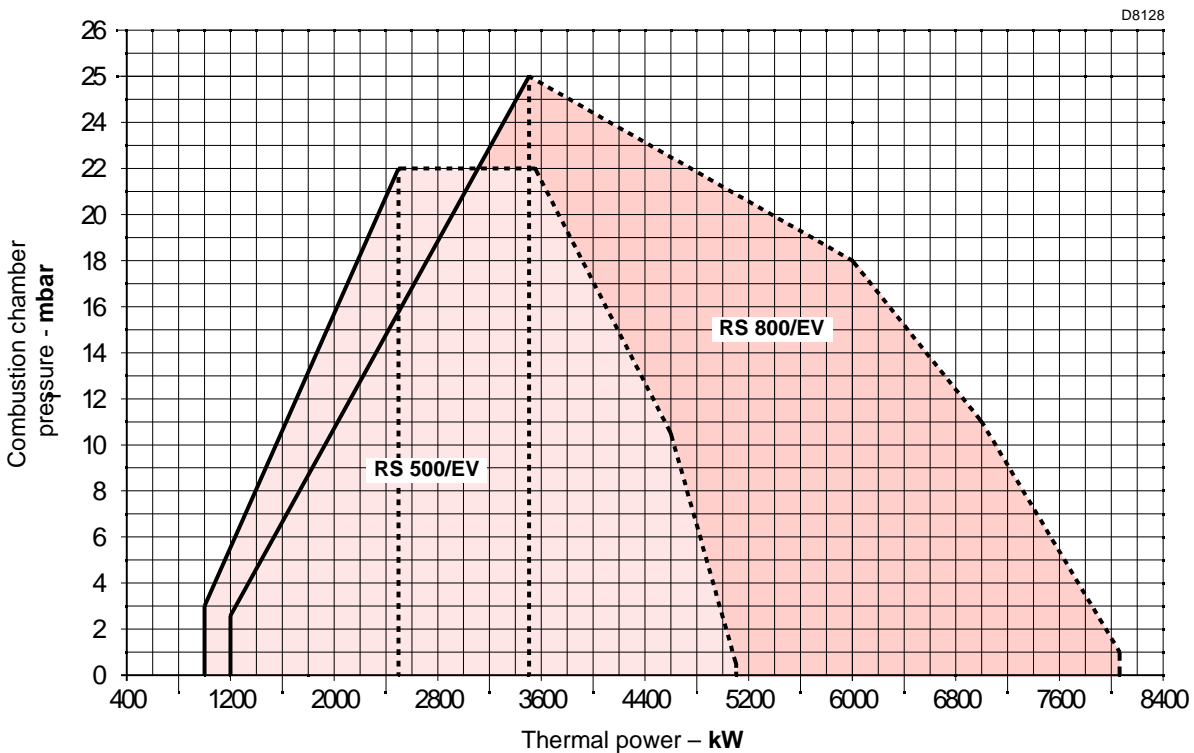
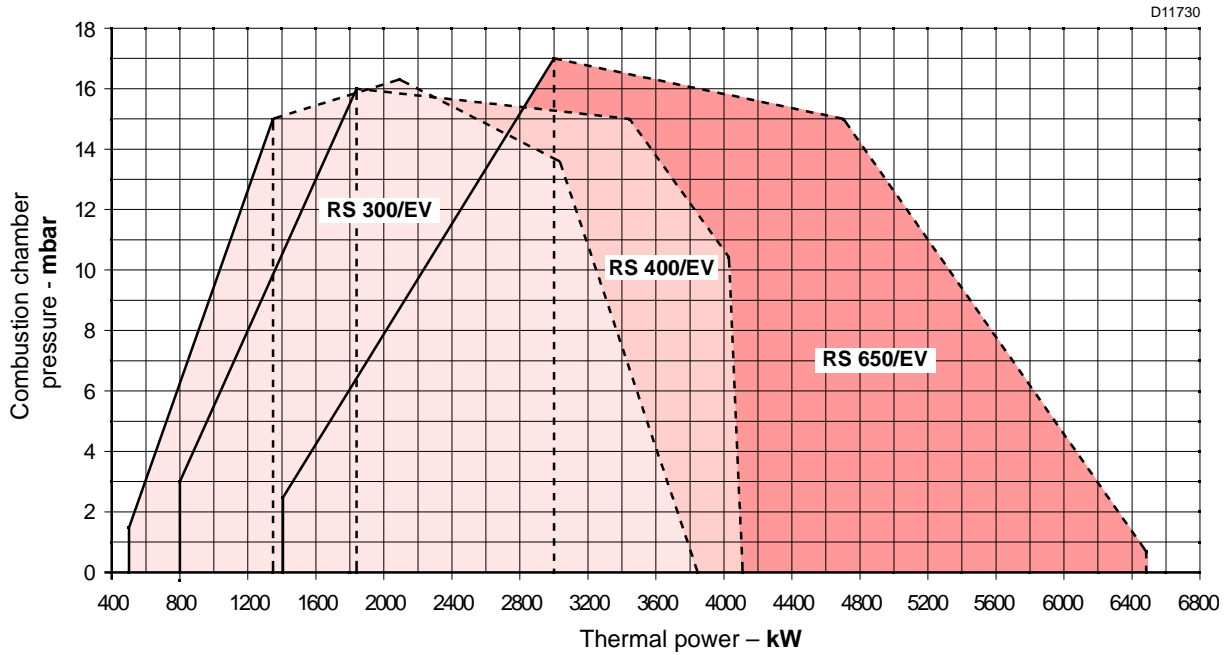

Fig. 2

**4.8 Test boiler**

The burner/boiler combination does not pose any problems if the boiler is EC approved and its combustion chamber dimensions are similar to those indicated in the diagram (Fig. 3).

If the burner must be combined with a boiler that has not been EC approved and/or its combustion chamber dimensions are clearly smaller than those indicated in the diagram, consult the manufacturer.

The firing rates were obtained in special test boilers, according to EN 676 regulations.

In Fig. 3 you can see the diameter and length of the test combustion chamber.

**Example: RS 800/EV BLU**

Output 7000 kW - diameter 120 cm - length 6 m.

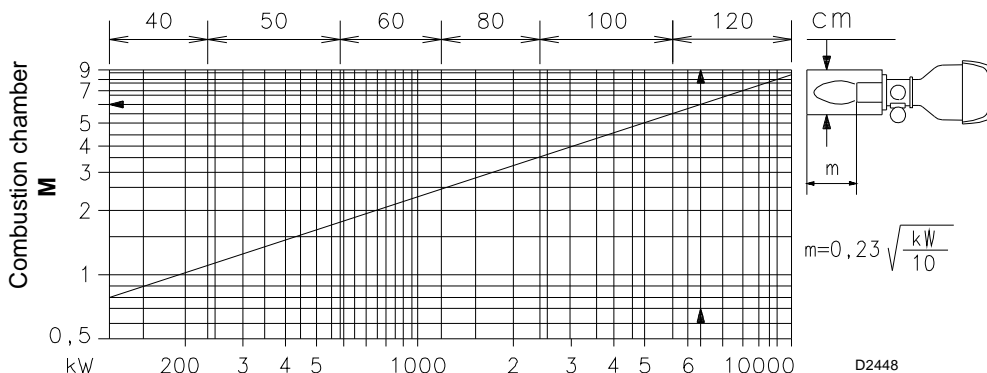

**Fig. 3**

**4.9 Burner equipment**

- Gasket for gas train adaptor . . . . . No. 1
- M16 x 70 Screws to fix the gas train adaptor . . . . . No. 8
- Thermal insulation screen . . . . . No. 1
- M 18 x 60 screws to secure the burner flange to the boiler No. 4
- Pressure switch (for leak detection control) . . . . . No. 1
- M16 x 67 stud bolts to fix the gas elbow to the pipe coupling (for RS 650-800/EV BLU only) . . . . . No. 8
- Cable grommets kit for optional electrical wiring input . . . . No. 1
- M16 nuts to fix the gas elbow to the pipe coupling (for RS 650-800/EV BLU only) . . . . . No. 8
- Spacers (Fig. 16 on page 20) . . . . . No. 2
- Instructions . . . . . No. 1
- Spare parts list . . . . . No. 1

**4.10 Burner description**

- 1 Lifting rings
- 2 Fan
- 3 Fan motor
- 4 Air damper servomotor
- 5 Combustion head gas pressure test point
- 6 Combustion head
- 7 Ignition electrode
- 8 Flame stability disc
- 9 Electrical panel casing
- 10 Gas butterfly valve servomotor
- 11 Fan air inlet
- 12 Pipe coupling
- 13 Gasket for boiler fixing
- 14 Gas butterfly valve
- 15 Shutter
- 16 Combustion head movement lever
- 17 Air damper movement gears
- 18 Air pressure switch
- 19 Combustion head air pressure test point
- 20 Maximum gas pressure switch with pressure test point
- 21 Flame sensor probe
- 22 Hinge for opening the burner
- 23 Pressure test point for air pressure switch "+"
- 24 Pressure test point for air pressure switch "-"
- 25 Rpm sensor
- 26 Gas inlet flange

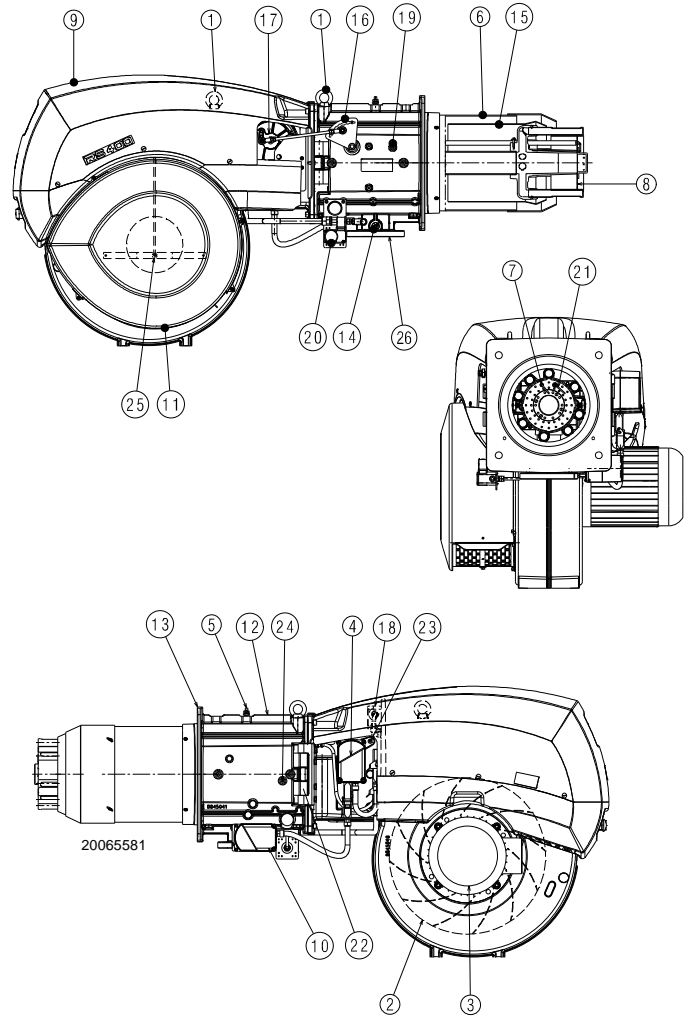

The burner can be opened to the right or to the left without links to the fuel supply side.  
When the burner is closed, the hinge can be refitted on the opposite side.

**Fig. 4**

4.11 Electrical panel description

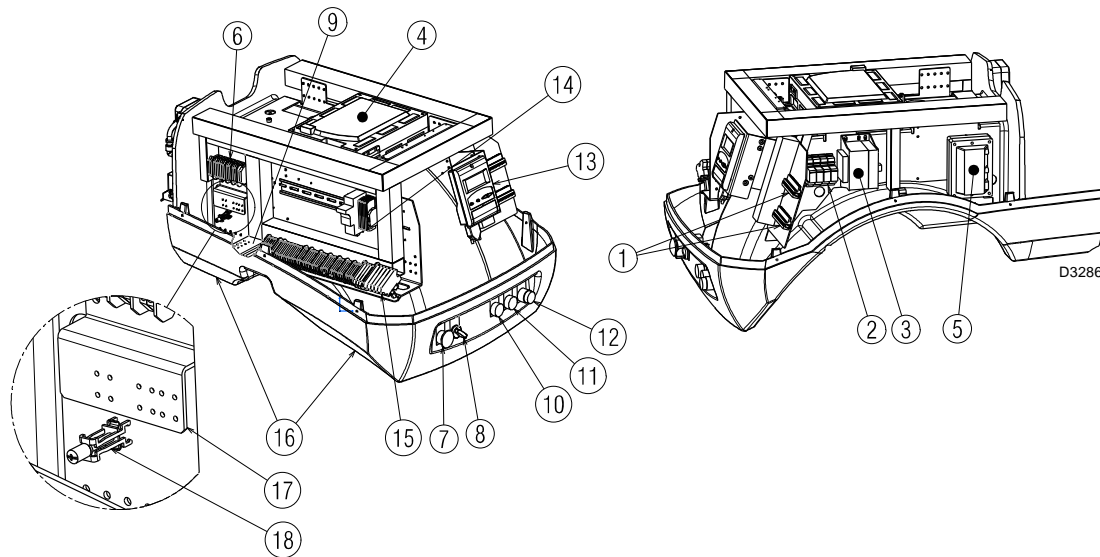

Fig. 5

- 1 O2 kit plugs-sockets
- 2 Clean contacts output relay
- 3 Electronic cam transformer
- 4 Calibration device with electronic cam
- 5 Ignition transformer
- 6 O2 sensor terminal board
- 7 Stop push-button
- 8 Off-automatic selector
- 9 Bracket for shielding and fixing shielded cables of the regulating probes
- 10 Warning lamp for voltage of auxiliaries
- 11 Fan motor lock-out warning lamp
- 12 Burner lockout warning lamp and reset switch
- 13 AZL display
- 14 Auxiliary terminal board
- 15 Main terminal supply board and Inverter kit
- 16 Supply cables, external connections and kits
- 17 Bracket for shielding and Kit O2 shielded cables
- 18 Clamp for shielded cables:



Do not overtighten, as it only ensures the continuity of the cable shielding.

**NOTE**

Two types of burner lockout may occur:

- **Flame control lockout:** if the pilot light 12)(Fig. 5) on the panel lights up, it indicates that the burner is in lockout. release by pressing the pushbutton 12)(Fig. 5).
- **Motor lockout:** refer to the Inverter manual.

The inverter kit and O2 kit must be connected by the client/installing technician in accordance with the respective documentation (wiring diagrams) supplied with burner and the kits themselves.

**4.12 Control box for the air/fuel ratio (LMV52...)**

**Warnings**



To avoid accidents, material or environmental damage, observe the following instructions!

The LMV52 control box... is a safety device! Avoid opening or modifying it, or forcing its operation. Riello S.p.A. cannot assume any responsibility for damage resulting from unauthorised interventions!

**Risk of explosion!**

An incorrect configuration can provoke fuel overcharging, with the consequential risk of explosion! Operators must be aware that incorrect settings made on the AZL5... display and operating unit and incorrect settings of the fuel and / or air actuator positions can lead to dangerous burner operating conditions.

- All interventions (assembly and installation operations, assistance, etc.) must be carried out by qualified personnel.
- Before modifying the wiring in the LMV52 control box connection area, fully disconnect the system from the power supply (omnipolar separation). Check the system is not powered and cannot be accidentally reconnected. Failure to do this will lead to the risk of electrocution.
- Protection against electrocution from the LMV5... control box and all connected electric components is obtained with correct assembly.
- Before any intervention (assembly and installation operations, assistance, etc.), ensure the wiring is in order and that the parameters are correctly set, then make the safety checks.
- Falls and collisions can negatively affect the safety functions.

In this case, the control box must not be operated, even if it displays no evident damage.

- In programming mode, the position check of actuators and VSD (checking electronic fuel / air ratio control) is different from the check during automatic operation.

As for automatic operation, the actuators are guided together to the positions requested and, if an actuator does not reach the position requested, adjustments are made until the position is actually reached. However, in contrast to automatic operation, there are no time limits to these corrective actions.

The other actuators maintain their positions until all actuators have reached the positions currently required.

This is absolutely important to set the fuel / air ratio control system.

During the time the fuel / air ratio curves are being programmed, the person making the plant settings must continuously monitor the quality of the combustion process (e.g. by means of a flue gas analyzer).

Also, if combustion levels are poor, or in the event of dangerous situations, the commissioning engineer must take appropriate action (e.g. switching off manually).

To ensure the safety and reliability of the LMV5... system, the following instructions must also be followed:

- avoid conditions that can favour the development of condensate and humidity. Otherwise, before switching on again, make sure that the entire control box is perfectly dry!

- Static charges must be avoided since they can damage the control box's electronic components when touched.



**Fig. 6**

**Mechanical structure**

The LMV5... control box is a system to check the burners, based on a microprocessor and equipped with components to adjust and monitor medium and large capacity forced draught burners. The base control box of the LMV5... system incorporates the following components:

- Burner control with gas valve proving system
- Electronic fuel / air ratio control with a maximum of 4 (LMV51...) or 6 (LMV52...) actuators
- Optional PID temperature / pressure controller (load controller)
- Optional VSD module Mechanical design

**Installation notes**

- Check the electric wiring inside the boiler complies with the national and local safety regulations.
- Do not confuse the powered conductors with the neutral ones.
- Make certain that strain relief of the connected cables is in compliance with the relevant standards (e.g. as per DIN EN 60730 and DIN EN 60 335).
- Ensure that spliced wires cannot get into contact with neighboring terminals. Use adequate ferrules.
- Arrange the HV ignition cables separately, as far as possible from the control box and the other cables.
- The burner manufacturer must protect unused AC 230 V terminals with dummy plugs (refer to sections Suppliers of other accessory items).
- When wiring the unit, make sure that AC 230 V mains voltage cables are run strictly separate from extra low-voltage cables to avoid risks of electrical shock hazard.



## Electrical connection of ionization probe and flame detector

It is important for signal transmission to be almost totally free of any disturbances or loss:

- always separate the detector cables from the other cables:
  - Line capacitance reduces the magnitude of the flame signal.
  - Use a separate cable.

- Respect the allowed cable lengths.
- The ionisation probe is not protected against the risk of electrocution. When connected to the electricity supply, the ionisation probe must be protected against any accidental contact.
- **Position the ignition electrode and the ionisation probe so that the ignition spark cannot form an arc on the probe (risk of electric overcharge).**

## Technical data

LMV52... base control box	Mains voltage	AC 230V -15% / +10%	
	Mains frequency	50 / 60 Hz ±6 %	
	Power absorption	< 30W (normal)	
	Safety class	I, with components in compliance with II and III, according to DIN EN 60730-1	
Load on 'input' terminals	F1 unit fuse (internal)	6.3 AT	
	Main fuse of perm. network (external)	Max. 16 AT	
	Undervoltage		
	• Safety switch-off from operating position to mains voltage	< AC 186 V	
	• Restart when mains voltage picks up	> AC 188 V	
	Oil pump / magnetic clutch (nominal voltage)		
• Nominal current	2A		
• Power factor	cosφ > 0.4		
Air pressure switch test valve (nominal voltage)	• Nominal current	0.5A	
	• Power factor	cosφ > 0.4	
	Load on 'output' terminals	<b>Total load on the contacts:</b>	
		• Mains voltage	AC 230 V -15 % / +10 %
• Total unit input current (safety circuit) load on contacts due to:	Max. 5 A		
	- Fan motor contactor		
	- Ignition transformer		
	- Valve		
	- Oil pump / magnetic clutch		
	<b>Single contact loading:</b>		
	Fan motor contactor (nominal voltage)		
	• Nominal current	1A	
	• Power factor	cosφ > 0.4	
	Alarm output (nominal voltage)		
	• Nominal current	1A	
	• Power factor	cosφ > 0.4	
	Ignition transformer (nominal voltage)		
	• Nominal current	2A	
	• Power factor	cosφ > 0.2	
	Fuel gas valve (nominal voltage)		
	• Nominal current	2A	
	• Power factor	cosφ > 0.4	
	Fuel oil valve (nominal voltage)		
	• Nominal current	1A	
	• Power factor	cosφ > 0.4	
Cable lengths	Main line	Max. 100 m (100 pF/m)	
Environmental conditions	Operation	DIN EN 60721-3-3	
	Climatic conditions	Classe 3K3	
	Mechanical conditions	Classe 3M3	
	Temperature range	-20...+60°C	
	Humidity	< 95% RH	

**Tab. G**

**4.13 Servomotor (SQM48.4....)**

**Warnings**



**To avoid accidents, material or environmental damage, observe the following instructions!**

**Avoid opening, modifying or forcing the actuators.**

- All interventions (assembly and installation operations, assistance, etc.) must be carried out by qualified personnel.
- Before modifying the wiring in the SQM4... system connection area, fully disconnect the burner control device from the power supply (omnipolar separation).
- To avoid the risk of electrocution, protect the connection terminals in a suitable manner and correctly fix the cover.
- Check the wiring is in order.
- Falls and collisions can negatively affect the safety functions. In this case, the unit must not be operated, even if it displays no evident damage.

**Assembly notes**

- Check the relevant national safety standards are respected.
- The connection between the actuator command shaft and the control element must be rigid, without any mechanical play.
- To avoid an excessive load on the bearings due to rigid hubs, the use of compensation clutches without any mechanical play is recommended (e.g. metal bellows-type clutches).

**Installation notes**

- Arrange the H.V. ignition cables separately, as far as possible from the control box and the other cables.
- To avoid the risk of electrocution, make sure that the 230V AC section of the SQM4... unit is fully separated from the functional low-voltage section.
- The static torque is reduced when the electrical supply of the actuator is switched off.
- The housing cover may only be removed for short periods of time for wiring or when making the addressing. In similar cases, make sure that dust or dirt does not penetrate inside the actuator.
- The actuator comprises a PCB with ESD-sensitive components.
- The top side of the board carries a cover which affords protection against direct contact. This protective cover must not be removed! The underside side of the board must not be touched.



**During the maintenance or replacement of the actuators, be careful not to invert the connectors.**

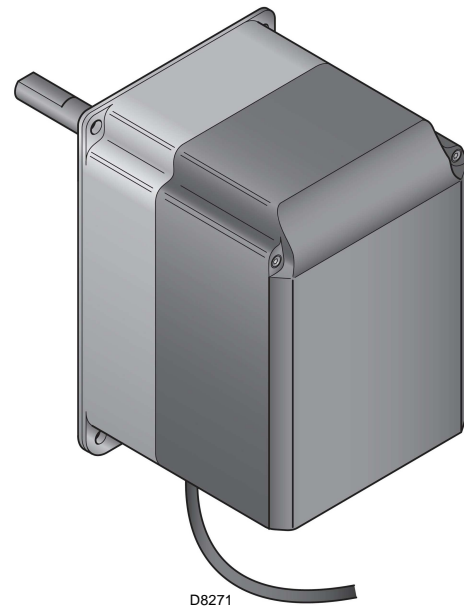

**Fig. 7**

**Technical data**

Operating voltage	AC 2 x 12 V via bus cable from the base unit or via a separate transformer
Safety class	extra low-voltage with safe isolation from mains voltage
Power consumption	26...34 VA
Degree of protection	to EN 60 529, IP 54, provided adequate cable entries are used
Cable connection	RAST3,5 connectors
Rotation direction	- Anticlockwise (standard) - Clockwise (inverted rotation)
Nominal torque (max)	20 Nm
Holding torque (max)	20 Nm
Running time (min.) for 90°	30 s.
Weight	approx. 1.6 kg
Environmental conditions:	
Operation	DIN EN 60 721-3-3
Climatic conditions	Classe 3K3
Mechanical conditions	Classe 3M3
Temperature range	-20...+60°C
Humidity	< 95% RH

**Tab. H**

**5 Installation**

**5.1 Notes on safety for the installation**

After carefully cleaning all around the area where the burner will be installed, and arranging the correct lighting of the environment, proceed with the installation operations.



All the installation, maintenance and disassembly operations must be carried out with the electricity supply disconnected.



The installation of the burner must be carried out by qualified personnel, as indicated in this manual and in compliance with the standards and regulations of the laws in force.



Combustion air inside the boiler must be free from hazardous mixes (e.g.: chloride, fluoride, halogen); if present, it is highly recommended to carry out cleaning and maintenance more frequently.

**5.2 Handling**

The packaging of the burner includes a wooden platform, so it is possible to move the burner (still packaged) with a transpallet truck or fork lift truck.



The handling operations for the burner can be highly dangerous if not carried out with the greatest attention: keep any unauthorised people at a distance; check the integrity and suitability of the available means of handling. Check also that the area in which you are working is empty and that there is an adequate escape area (i.e. a free, safe area to which you can quickly move if the burner should fall). When handling, keep the load at not more than 20-25 cm from the ground.



After positioning the burner near the installation point, correctly dispose of all residual packaging, separating the various types of material.



Before proceeding with the installation operations, carefully clean all around the area where the burner will be installed.

**5.3 Preliminary checks**

**Checking the consignment**



After removing all the packaging, check the integrity of the contents. In the event of doubt, do not use the burner; contact the supplier.



The packaging elements (wooden cage or cardboard box, nails, clips, plastic bags, etc.) must not be abandoned as they are potential sources of danger and pollution; they should be collected and disposed of in the appropriate places.

RBL	A	B	C
D	E		F
GAS: KAASU	<input checked="" type="checkbox"/>	G	H
GAZ: AERIO		G	H
I			RIELLO SpA I-37045 Legnago (VR)
			CE

D10411

**Fig. 8**

**Checking the characteristics of the burner**

Check the identification label of the burner, showing:

- the model (A) (Fig. 8) and type of burner (B);
- the year of manufacture, in cryptographic form (C);
- the serial number (D);
- the data for electrical supply and the protection level (E);
- the absorbed electrical power (F);
- the types of gas used and the relative supply pressures (G);
- the data of the burner's minimum and maximum output possibilities (H) (see Firing rate)

**Warning.** The burner output must be within the boiler's firing rate;

- the category of the appliance/countries of destination (I).



A burner label, or any other component, that has been tampered with, removed or is missing, prevents the definite identification of the burner and makes any installation or maintenance work difficult.

**5.4 Operating position**



- The burner is designed to operate only in positions 1, 2, 3 and 4 (Fig. 9).
- Installation 1 is preferable, as it is the only one that allows the maintenance operations as described in this manual.
- Installations 2, 3 and 4 permit operation but make maintenance and inspection of the combustion head more difficult.



- Any other position could compromise the correct operation of the appliance.
- Installation 5 is prohibited for safety reasons.

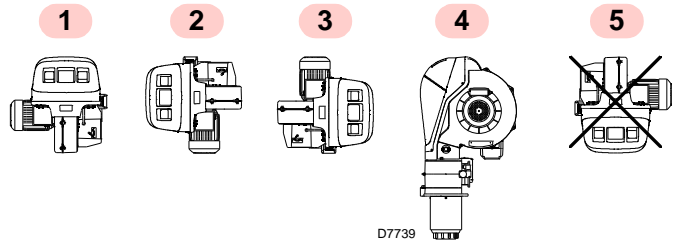

**Fig. 9**

**5.5 Removal of the locking screws from the shutter**



Remove the screws and the nuts 1)-2)(Fig. 10), before installing the burner on the boiler.

Replace them with the screws 3) M12 X 25 supplied with the burner.

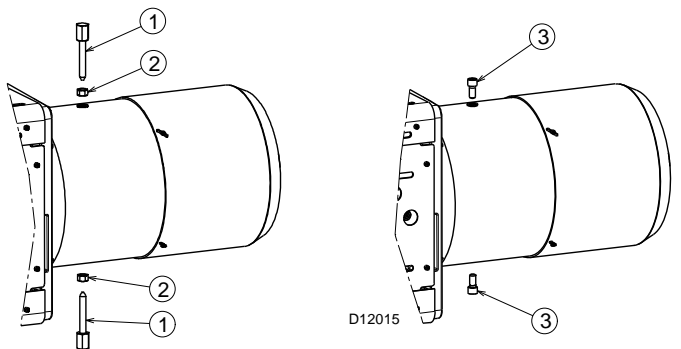

**Fig. 10**

**5.6 Preparing the boiler**

**5.6.1 Boring the boiler plate**

Pierce the closing plate of the combustion chamber, as in Fig. 11. The position of the threaded holes can be marked using the thermal insulation screen supplied with the burner.

**5.6.2 Blast tube length**

The length of the blast tube must be selected according to the indications provided by the manufacturer of the boiler, and in any case it must be greater than the thickness of the boiler door complete with its refractory.

For boilers with front flue passes 1) (Fig. 12) or flame inversion chamber, a protection in refractory material 5) must be inserted between the boiler fettling 2) and the blast tube 4).

This protection must not compromise the extraction of the blast tube.

For boilers with a water-cooled frontpiece, a refractory lining 2)-5) (Fig. 12) is not necessary, unless expressly requested by the boiler manufacturer.

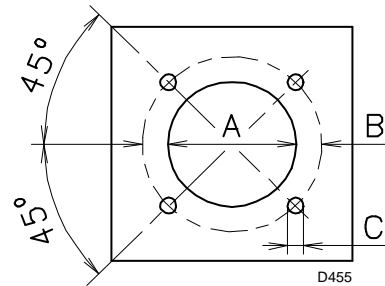

**Fig. 11**

mm	A	B	C
RS 300/EV BLU	350	452	M18
RS 400/EV BLU	350	452	M18
RS 500/EV BLU	390	452	M18
RS 650/EV BLU	400	495	M18
RS 800/EV BLU	400	495	M18

**Tab. I**

**5.7 Securing the burner to the boiler**



Prepare a suitable lifting system using the rings 3 (Fig. 12), after removing the fixing screws 7) of the casing 8).

- Fit the heat insulation supplied onto the blast tube (4) (Fig. 12).
- Fit the entire burner onto the boiler hole prepared previously (Fig. 11), and fasten with the screws supplied.



**WARNING**

**The seal between burner and boiler must be airtight.**

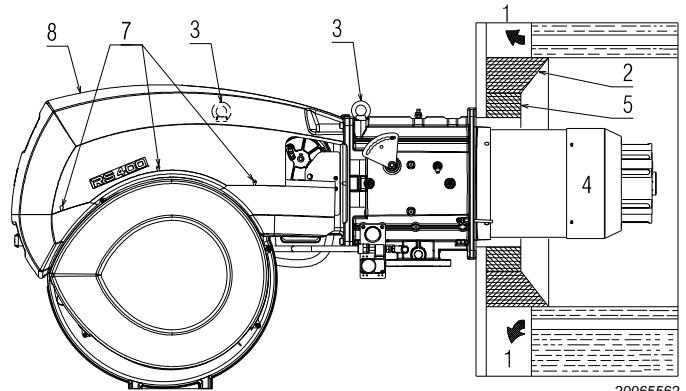

20065562

**Fig. 12**

**5.8 Access to head internal part**

- After you have uncoupled the head movement lever tie-rod 1) and removed the 4 fixing screws 2), open the burner on the hinge (Fig. 13),
- Unhook the probe cables and electrode 3).
- Tighten the underneath part of the elbow 4) until it is released from its housing.
- Remove the internal part of the head 5).

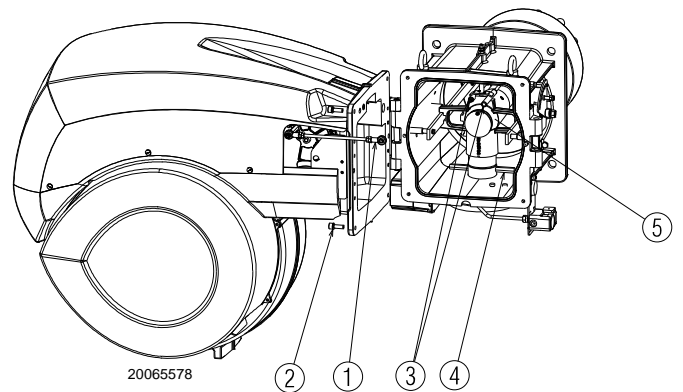

20065578

**Fig. 13**

**5.9 Probe-electrode position**



**WARNING**

Check that the probe and the electrode are placed as in Fig. 14, according to the dimensions indicated.

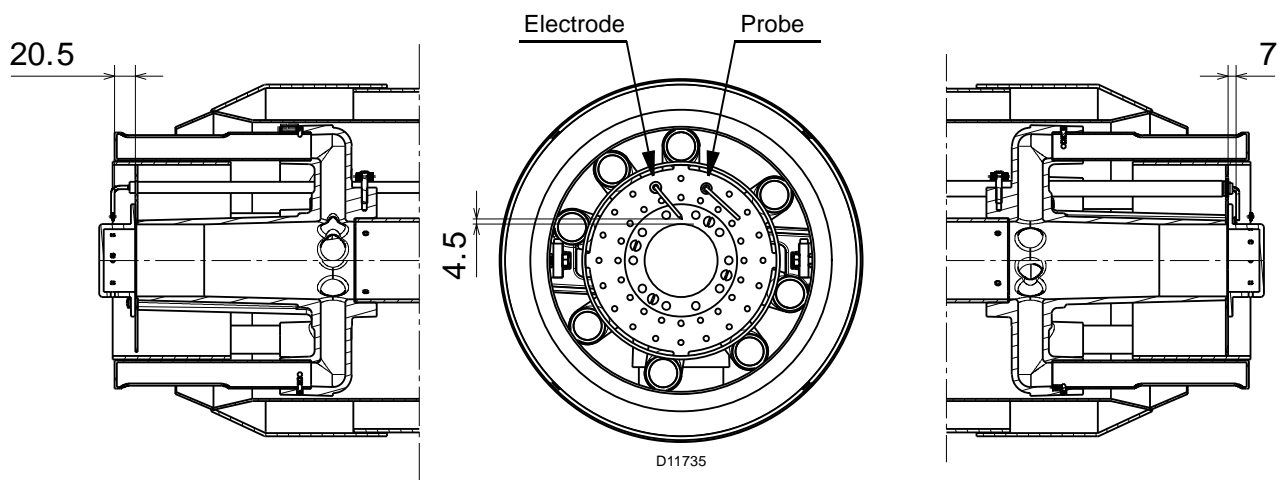

**Fig. 14**

### 5.10 Combustion head adjustment

The air damper servomotor 4)(Fig. 4 on page 12), beyond varying the air output according to the output demand, through a leverage varies the combustion head adjustment.

In the factory, the hole is adjusted for the minimum stroke (hole 1).



**WARNING**

Varying the tie-rod position on the holes 2) and 3) (Fig. 15) could cause instability during operation.



Pay attention to moving parts.  
Danger of crushing of limbs!

If it is necessary to move the hinge to the right, the spacers 4)(Fig. 16) supplied with the burner must be mounted.

For the assembly proceed as follows:

- after you have unscrewed the nuts 2), remove the tie-rod 3),
- Tighten the spacers 4) to spacer 1) and screw 5) respectively;
- mount the tie-rod and the nuts 2) again.



**WARNING**

**For RS 300-400-500/EV BLU only**

In order to work correctly in flame inversion boilers, the gas tubes must be adjusted in the hole in position 4, Fig. 17.

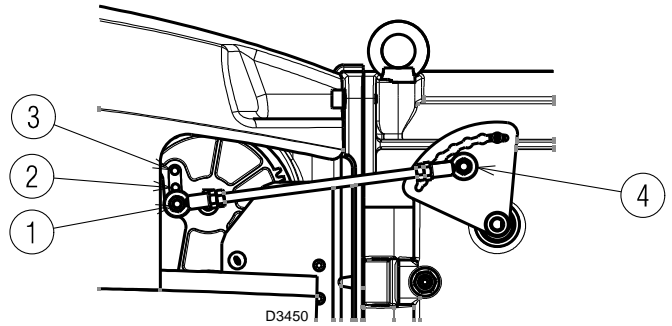

**Fig. 15**

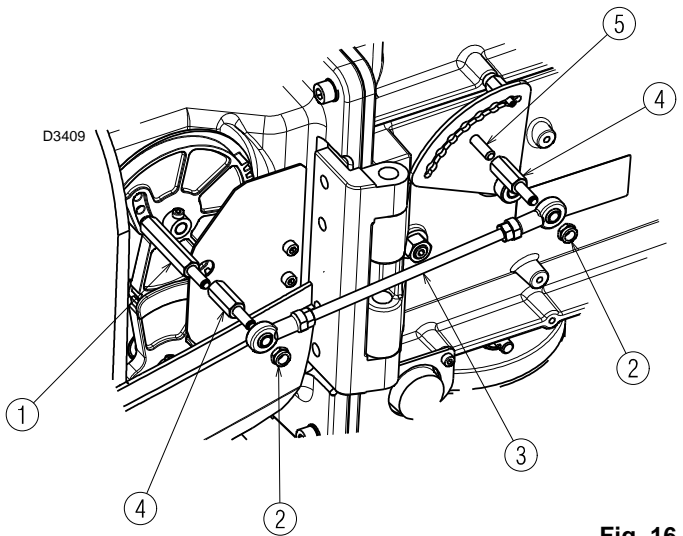

**Fig. 16**

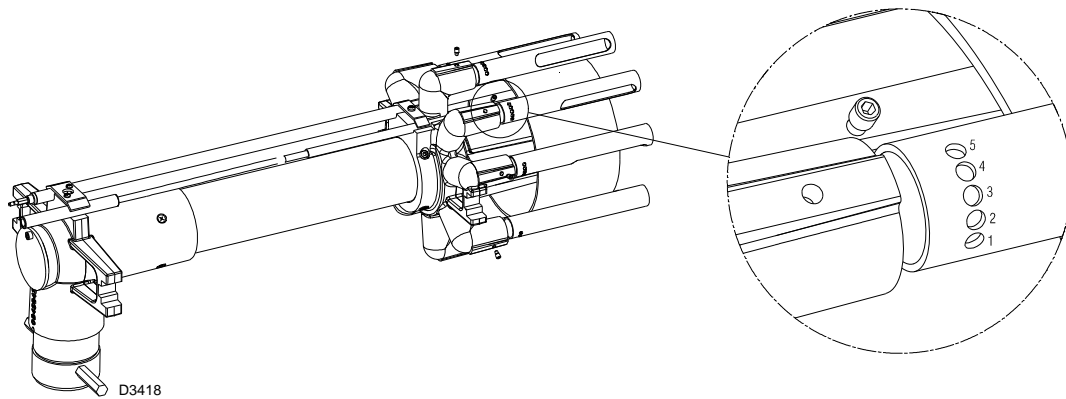

**Fig. 17**

**5.11 Gas feeding**



Explosion danger due to fuel leaks in the presence of a flammable source.

Precautions: avoid knocking, attrition, sparks and heat.

Make sure that the fuel interception tap is closed before performing any operation on the burner.



**WARNING**

The fuel supply line must be installed by qualified personnel, in compliance with current standards and laws.

**5.11.1 Gas feeding line**

Key (Fig. 18 - Fig. 19 - Fig. 20 - Fig. 21)

- 1 Gas input pipe
- 2 Manual valve
- 3 Vibration damping joint
- 4 Pressure gauge with pushbutton cock
- 5 Filter
- 6A Includes:
  - filter
  - working valve
  - safety valve
  - pressure adjuster
- 6B Includes:
  - working valve
  - safety valve
  - pressure adjuster
- 6C Includes
  - safety valve
  - working valve
- 6D Includes:
  - safety valve
  - working valve
- 7 Minimum gas pressure switch
- 8 Leak detection device, supplied as an accessory or incorporated, based on the gas train code. In compliance with the EN 676 standard, the leak detection control is compulsory for burners with maximum outputs over 1200 kW.
- 9 Gasket, for "flanged" versions only
- 10 Pressure adjuster
- P2 Upstream pressure of valves/adjuster
- P3 Upstream pressure of the filter
- L Gas train supplied separately
- L1 The responsibility of the installer

**MBC "threaded"**

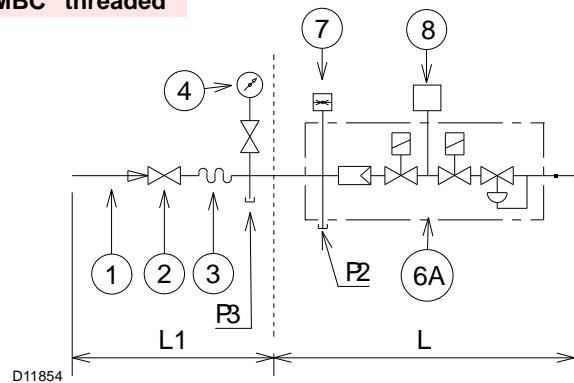

**Fig. 18**

**MBC "flanged"**

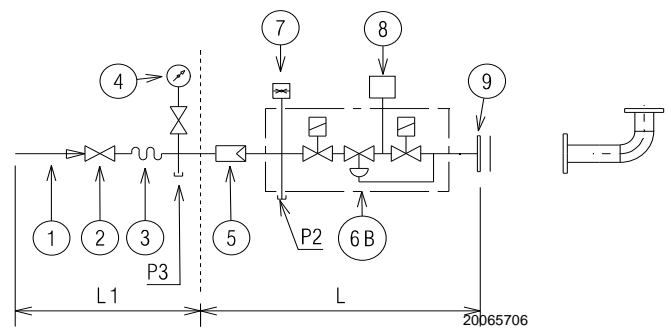

**Fig. 19**

**DMV "flanged or threaded"**

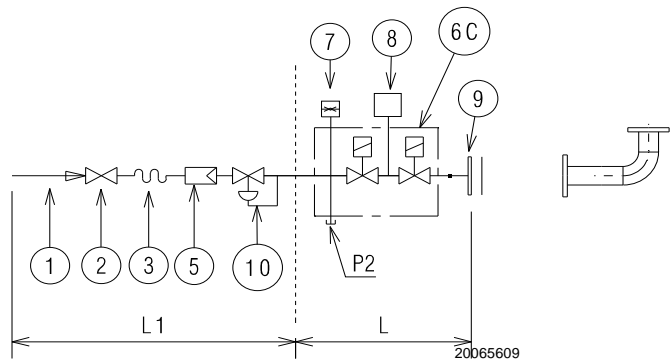

**Fig. 20**

**CB "flanged or threaded"**

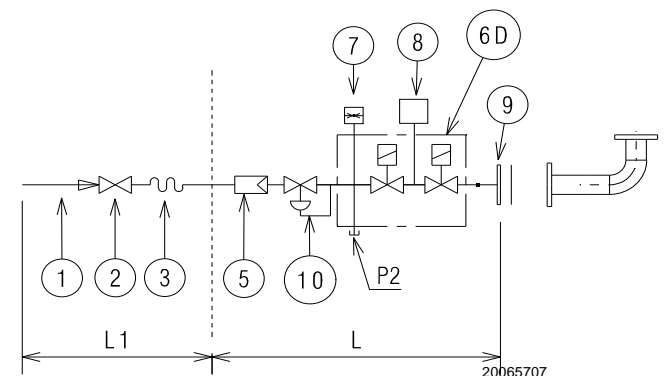

**Fig. 21**

### 5.11.2 Gas train

Type-approved in accordance with EN 676 and supplied separately from the burner.

To select the correct model of the gas train, refer to the “burner-gas train combination” manual supplied.



Beware of train movements: danger of crushing of limbs.



Make sure that the gas train is properly installed by checking for any fuel leaks.

### 5.11.3 Gas train installation



Disconnect the electrical power using the main system switch.



Check that there are no gas leaks.



The operator must use appropriate tools for installation.

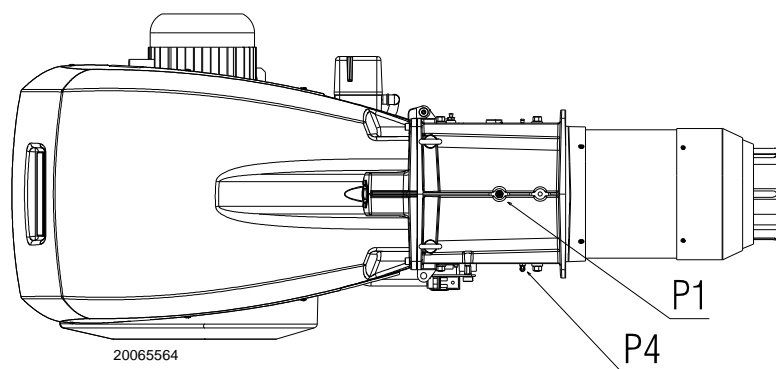

Fig. 22



**5.11.4 Gas pressure**

The Tab. J indicates the pressure drop of the combustion head and the gas butterfly valve depending on the operating output of the burner.

The values shown in Tab. J refer to:

- Natural gas G 20 NCV 9.45 kWh/Sm<sup>3</sup> (8.2 Mcal/Sm<sup>3</sup>)
- Natural gas G 25 NCV 8.13 kWh/Sm<sup>3</sup> (7.0 Mcal/Sm<sup>3</sup>)

Column 1

Pressure drop on combustion head.

Gas pressure measured at the test point P1) (Fig. 18), with:

- Combustion chamber at 0 mbar;
- Burner working at maximum modulating output;
- Combustion head adjusted as in page 20.

Column 2

Pressure loss at gas butterfly valve 10) (Fig. 18) with maximum opening: 90°.

To calculate the approximate output at which the burner operates:

- subtract the combustion chamber pressure from the gas pressure measured at test point P1) (Fig. 18).
- Find, in the table Tab. J related to the burner concerned, the pressure value closest to the result of the subtraction.
- read the corresponding output on the left.

**Example for RS 650/EV BLU with G20 natural gas:**

Maximum modulating output operation

$$\begin{aligned} \text{Gas pressure at test point P1)(Fig. 18)} &= 28.6 \text{ mbar} \\ \text{Pressure in combustion chamber} &= 5 \text{ mbar} \\ 28.6 - 5 &= 23.6 \text{ mbar} \end{aligned}$$

A pressure of 23.6 mbar, column 1, corresponds in the table Tab. J to an output of 4,500 kW.

This value serves as a rough guide; the effective output must be measured at the gas meter.

To calculate the required gas pressure at test point P1) (Fig. 18), set the maximum modulating output required from the burner operation:

- find the nearest output value in the table Tab. J for the burner in question.
- read, on the right (column 1), the pressure at the test point P1)(Fig. 18).
- Add this value to the estimated pressure in the combustion chamber.

**Example for RS 650/EV BLU with G20 natural gas:**

Maximum modulating output operation

$$\begin{aligned} \text{Gas pressure at an output of 4,500 kW} &= 23.6 \text{ mbar} \\ \text{Pressure in combustion chamber} &= 5 \text{ mbar} \\ 23.6 + 5 &= 28.6 \text{ mbar} \end{aligned}$$

Pressure required at test point P1)(Fig. 18).

	kW	1 Δp (mbar)		2 Δp (mbar)	
		G 20	G 25	G 20	G 25
RS 300/EV BLU	1,245	7.8	11.6	1.3	2.0
	1,500	9.4	13.9	1.9	2.8
	1,750	10.9	16.2	2.6	3.9
	2,000	12.4	18.5	3.4	5.0
	2,250	13.0	19.5	4.3	6.4
	2,500	13.7	20.4	5.3	7.9
	2,750	14.3	21.4	6.4	9.5
	3,000	15.0	22.4	7.6	11.3
	3,250	17.6	26.2	8.9	13.3
	3,500	20.2	30.1	10.3	15.4
RS 400/EV BLU	3,800	23.3	34.8	12.2	18.2
	1,800	6.3	9.3	2.9	4.3
	2,000	7.9	11.7	3.5	5.3
	2,250	9.9	14.7	4.5	6.7
	2,500	11.9	17.7	5.5	8.2
	2,750	13.9	20.7	6.7	10.0
	3,000	15.9	23.7	8.0	11.9
	3,250	17.9	26.7	9.3	13.9
	3,500	19.7	29.4	10.8	16.2
	3,750	21.1	31.4	12.4	18.6
RS 500/EV BLU	4,000	22.4	33.5	14.2	21.1
	4,250	27.4	40.8	16.0	23.8
	4,500	32.5	48.4	17.9	26.7
	2,500	11.5	17.2	0.6	0.8
	2,600	12.3	18.4	0.6	0.9
	2,800	13.9	20.8	0.7	1.0
	3,000	15.5	23.2	0.8	1.2
	3,200	17.1	25.5	0.9	1.4
	3,400	18.7	27.9	1.0	1.5
	3,600	20.5	30.6	1.2	1.7
RS 650/EV BLU	3,800	22.5	33.6	1.3	1.9
	4,000	24.5	36.6	1.4	2.1
	4,200	26.5	39.5	1.6	2.3
	4,400	28.5	42.5	1.7	2.6
	4,600	30.5	45.5	1.9	2.8
	4,800	33.0	49.2	2.0	3.1
	5,000	35.5	53.0	2.2	3.3
	5,200	38.0	56.7	2.4	3.6
	3,000	11.0	13.7	1.0	1.5
	3,250	13.1	16.7	1.1	1.7
3,500	15.2	19.8	1.3	2.0	
3,750	17.3	22.8	1.5	2.3	
4,000	19.4	25.8	1.7	2.6	
4,250	21.5	28.9	1.9	2.9	
4,500	23.6	31.9	2.1	3.3	
4,750	25.7	35.1	2.4	3.7	
5,000	28.4	39.3	2.6	4.0	
5,250	31.2	43.5	2.9	4.5	
5,500	33.9	47.7	3.2	4.9	
5,750	36.6	51.9	3.5	5.4	
6,000	39.3	56.0	3.8	5.8	
6,250	42.1	60.2	4.1	6.3	
6,500	44.8	64.4	4.5	6.8	
RS 800/EV BLU	3,500	9.4	12.8	0.6	0.7
	4,000	12.8	17.7	0.7	0.9
	4,500	16.2	22.5	0.9	1.1
	5,000	19.6	27.3	1.2	1.4
	5,500	23.0	32.1	1.4	1.7
	6,000	26.4	37.0	1.7	2.0
	6,500	30.9	44.7	2.0	2.3
	7,000	35.5	52.4	2.3	2.7
	7,500	40.9	59.8	2.6	3.1
	8,000	46.3	67.1	3.0	3.5
8,060	47.0	68.0	3.0	3.5	

Tab. J

**5.12 Electrical wiring**

**Notes on safety for the electrical wiring**



- The electrical wiring must be carried out with the electrical supply disconnected.
- Electrical wiring must be made in accordance with the regulations currently in force in the country of destination and by qualified personnel. Refer to the wiring diagrams.
- The manufacturer declines all responsibility for modifications or connections different from those shown in the wiring diagrams
- Check that the electrical supply of the burner corresponds to that shown on the identification label and in this manual.
- The burner has been type-approved for continuous use. This means they should compulsorily be stopped at least once every 72 hours to enable the control box to perform checks of its own start-up efficiency. Normally, burner stopping is guaranteed by the boiler's thermostat/pressure switch.
- If this is not the case, a time switch should be fitted in series to TL to stop the burner at least once every 72 hours. Refer to the wiring diagrams.
- The electrical safety of the device is obtained only when it is correctly connected to an efficient earthing system, made according to current standards. It is necessary to check this fundamental safety requirement. In the event of doubt, have the electrical system checked by qualified personnel. Do not use the gas tubes as an earthing system for electrical devices.
- The electrical system must be suitable for the maximum power absorption of the device, as indicated on the label and in the manual, checking in particular that the section of the cables is suitable for that level of power absorption.
- For the main power supply of the device from the electricity mains:
  - do not use adapters, multiple sockets or extensions;
  - use a multiple pole switch with at least a 3 mm gap between the contacts (overvoltage category III), as envisaged by the present safety standards.
- Do not touch the device with wet or damp body parts and/or in bare feet.
- Do not pull the electric cables.

Before carrying out any maintenance, cleaning or checking operations:



Disconnect the electrical supply from the burner by means of the main system switch.



Close the fuel interception tap.



Avoid condensate, ice and water leaks from forming.

If the hood is still present, remove it and proceed with the electrical wiring according to the wiring diagrams.

Use flexible cables in compliance with the EN 60 335-1 standard.

**5.12.1 Supply cables and external connections passage**

All the cables to be connected to the burner must be threaded through cable grommets. The use of the cable grommets can take various forms. by way of example see Fig. 23.

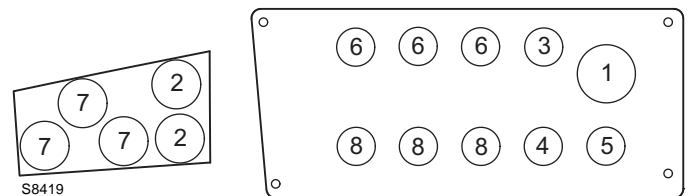

**Fig. 23**

Key (Fig. 23)

- 1 Electrical supply
- 2 Regulating probes
- 3 minimum gas pressure switch
- 4 Pressure switch kit for PGVP gas valve leak detection
- 5 Gas train
- 6 Consents/Safety
- 7 O2 kit probes and O2 kit supply
- 8 available



Perform all maintenance, cleaning or inspection operations and mount the casing again.

**6 Start-up, calibration and operation of the burner**

**6.1 Notes on safety for the first start-up**



The first start-up of the burner must be carried out by qualified personnel, as indicated in this manual and in compliance with the standards and regulations of the laws in force.



Check the correct working of the adjustment, command and safety devices.

**6.2 Adjustments prior to ignition**

Combustion head adjustment is already described on page 20.

In addition, the following adjustments must also be made:

- open manual valves upline from the gas train.
- Adjust the minimum gas pressure switch to the start of the scale.
- Adjust the maximum gas pressure switch to the end of the scale.
- Adjust the air pressure switch to the start of the scale.
- Purge the air from the gas line.

We recommend using a plastic tube routed outside the building and to purge air until gas is smelt.

- Fit a U-type pressure gauge or a differential pressure gauge (Fig. 24), with socket (+) on the gas pressure of the pipe coupling and (-) in the combustion chamber.

The manometer readings are used to calculate MAX burner output using the Tab. J.

- Connect two lamps or testers to the two gas line solenoids to check the exact moment in which voltage is supplied. This operation is unnecessary if each of the two solenoids is equipped with a pilot light that signals voltage passing through.



Before starting up the burner, it is good practice to adjust the gas train so that ignition takes place in conditions of maximum safety, i.e. with gas delivery at the minimum.

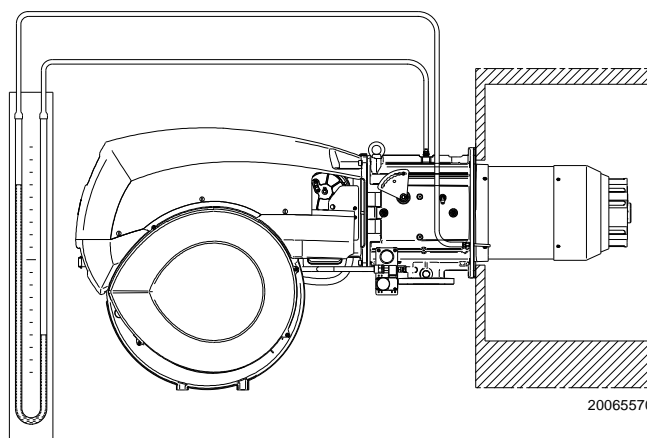

20065570

**Fig. 24**



Configure the Inverter according to the manual and the instructions supplied.

**6.3 Burner start-up**

Close all consents and safety devices and put the selector to position "AUTO" (Fig. 25).

Select the "MANUAL" mode (for further information refer to the relevant control box manual).



Make sure that the lights or testers connected to the solenoids, or the pilot lights on the solenoids themselves, indicate that no voltage is present. If voltage is present, stop the burner immediately and check the electrical connections.

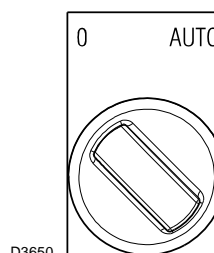

D3650

**Fig. 25**

**6.4 Burner ignition**

Once the above steps are complete, the burner should light.

If the motor starts up, but the flame does not appear and the control box goes into lockout, reset it and wait for a new ignition attempt.

If ignition does not occur, it may be that gas is not reaching the combustion head within the safety time period of 3 seconds. In this case, increase gas ignition delivery.

The arrival of gas at the pipe coupling is indicated by the U-type pressure gauge (Fig. 24).

Once the burner has ignited, proceed with the global adjustment of the burner.

Once regulations have been made, select the "AUTOMATIC" mode on the AZL display.

**6.5 Combustion air adjustment**

Fuel/combustion air synchronization is done with the relevant servomotors (air and gas) by logging a calibration curve by means of the electronic cam.

It is advisable, to reduce the loss and for a wide calibration field, to adjust the servomotors to the maximum of the output used, the nearest possible to the maximum opening (90°).

On the gas butterfly valve, fuel step according to the burner output required, with servomotor completely open, is carried out by the pressure stabilizer placed on the gas train.

If the O<sub>2</sub> control kit is present, follow the commissioning operations indicated in the relevant LMV manual, supplied at the time of training by the Technical Assistance Service.

**6.5.1 Air adjustment for maximum output**

**Excluding RS 800/EV BLU model**

- Adjust the servomotor to maximum opening (nearly 90°) so that the air butterfly valves are entirely open;
- Loosen the screw 2 (Fig. 26) placed under the burner suction line and close progressively the grid 1 until the required output is reached.

Steps in suction line are not necessary only in case in which the burner is working at maximum of the firing rate on page 10.



It is advisable to reach the maximum output required manually and, just after defining the steps in suction line, the gas pressure and the combustion head adjustment, carry out complete calibration and logging of the fuel/combustion synchronisation curves.

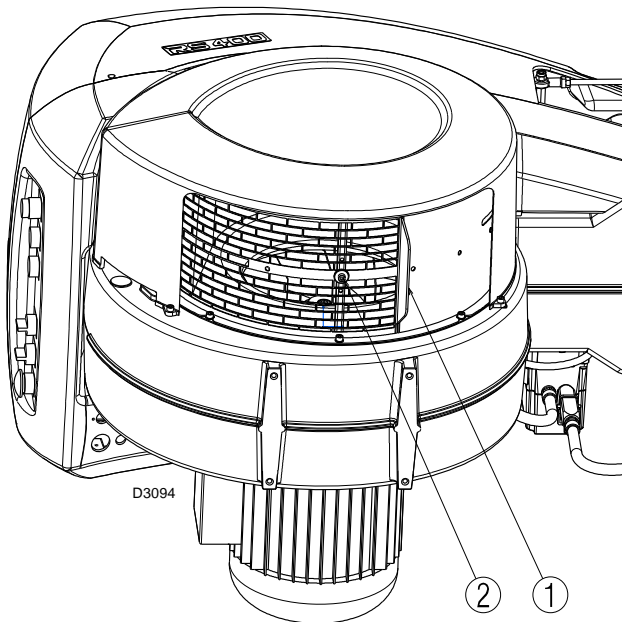

**Fig. 26**

**6.5.2 Air/fuel adjustment and output modulation system**

The air/gas regulator and output modulation system equipping **RS/EV** series burners performs a number of integrated functions in a single control device in order to optimise burner function, in both individual installations and in combination with other units (e.g. double furnace boiler or multiple heat generators in parallel).

The basic system functions control:

- 1 The dosage of the air and fuel through positioning using direct servocommands of the relevant valves eliminating the possible play in the calibration systems with mechanical cam lever mechanisms, used on traditional modulating burners.
- 2 The modulation of the burner output in accordance with the load required by the system, with maintenance of the pressure or temperature of the boiler at the operating values set.
- 3 the fine, continuous adjustment of the air flow rate according to the gas analysis made at the flue (O<sub>2</sub>); this function requires the O<sub>2</sub> kit, containing the PLL module and the QGO<sub>2</sub> sensor;
- 4 the measurement of the combustion yield (this function requires the O<sub>2</sub> kit);
- 5 the sequence (cascade adjustment) of several boilers, suitably connected.

Further interfaces and communication functions with computers, for remote control or integration in central supervision systems are available on the basis of the configuration of the system.



**WARNING**

The first start up and every further internal setting operation of the adjustment system or the expansion of the base functions require access by means of password and are to be carried out by service personnel who are especially trained for the internal programming of the instrument and the specific application created with this burner.

The specific reference manual for the instrument is supplied during training to provide technical assistance.

## 6.6 Pressure switch adjustment

### 6.6.1 Air pressure switch - check CO

Adjust the air pressure switch (Fig. 27) after performing all other burner adjustments with the air pressure switch set to the start of the scale.

With the burner working at MIN output, insert a combustion analyser in the stack, slowly close the suction inlet of the fan (for example, with a piece of cardboard) until the CO value does not exceed 100 ppm.

Slowly turn the appropriate knob clockwise until the burner goes into lockout.

Check the indication of the arrow pointing upwards on the graduated scale. Turn the knob clockwise again, until the value shown on the graduated scale corresponds with the arrow pointing downwards, and so recovering the hysteresis of the pressure switch (shown by the white mark on a blue background, between the two arrows).

Now check the correct start-up of the burner.

If the burner locks out again, turn the knob anticlockwise a little bit more.

On **RS 300-400-500/EV BLU** burners the air pressure switch is fitted in a "differential" mode, that is, with two pipes connected to the specific pressure test points "+" and "-" 22)-23)(Fig. 4 on page 12).

On **RS 650-800/EV BLU** burners the air pressure switch is fitted in an "absolute" mode, that is, connected only to the pressure test point "+" 22) (Fig. 4 on page 12).



Fig. 27

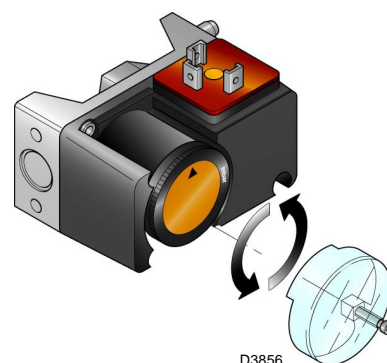

Fig. 28

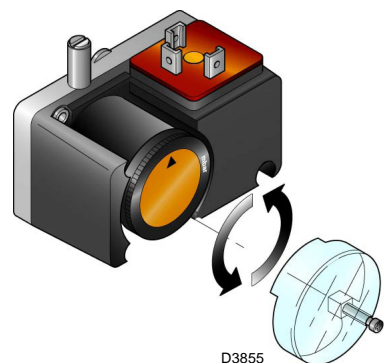

Fig. 29

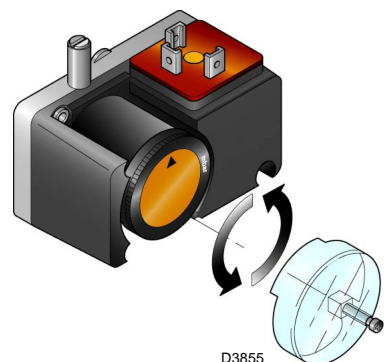

Fig. 30

### 6.6.2 Maximum gas pressure switch

Adjust the maximum gas pressure switch (Fig. 28) after performing all other burner adjustments with the maximum gas pressure switch set to the end of the scale.

With the burner operating at maximum output, lower adjustment pressure by slowly turning the relative knob anticlockwise until the burner locks out.

Turn the knob clockwise by 2 mbar and repeat the start-up of the burner.

If the burner locks out again, turn the knob clockwise again by 1 mbar.

### 6.6.3 Minimum gas pressure switch

Adjust the minimum gas pressure switch (Fig. 29) after performing all the other burner adjustments with the pressure switch set to the start of the scale.

With the burner operating at maximum output, increase adjustment pressure by slowly turning the relative knob clockwise until the burner locks out.

Then turn the knob anticlockwise by 2 mbar and repeat burner start-up to ensure it is uniform.

If the burner locks out again, turn the knob anticlockwise again by 1 mbar.

### 6.6.4 PVP pressure switch kit

Adjust the pressure switch for the leak detection control (Fig. 30) according to the instructions supplied with the kit.

**7 Maintenance**

**7.1 Notes on safety for the maintenance**

The periodic maintenance is essential for the good operation, safety, yield and duration of the burner. It allows you to reduce consumption and polluting emissions and to keep the product in a reliable state over time.



The maintenance interventions and the calibration of the burner must only be carried out by qualified, authorised personnel, in accordance with the contents of this manual and in compliance with the standards and regulations of current laws.

Before carrying out any maintenance, cleaning or checking operations:



Disconnect the electrical supply from the burner by means of the main system switch.



Close the fuel interception tap.



Wait for the components in contact with heat sources to cool down completely.

**7.2 Maintenance programme**

**7.2.1 Maintenance frequency**



The gas combustion system should be checked at least once a year by a representative of the manufacturer or another specialised technician.

**7.2.2 Checking and cleaning**



The operator must use the required equipment during maintenance.

**Combustion**

Carry out an analysis of the combustion discharge gases. Significant differences with respect to the previous check indicate the points where more care should be exercised during maintenance.

**Combustion head**

Open the burner and make sure that all components of the combustion head are in good condition, not deformed by the high temperatures, free of impurities from the surroundings and correctly positioned.

**Burner**

Check that there are not excess wear or loosen screws. Clean the outside of the burner.

**Fan**

Check to make sure that no dust has accumulated inside the fan or on its blades, as this condition will cause a reduction in the air flow rate and provoke polluting combustion.

**Boiler**

Clean the boiler as indicated in its accompanying instructions in order to maintain all the original combustion characteristics intact, especially the flue gas temperature and combustion chamber pressure.

**Flame presence check**

The burner is fitted with an ionisation system to check that a flame is present. The minimum current for control box operation is 6  $\mu\text{A}$  (Fig. 31).

The burner provides a much higher current, so controls are not normally required.

However, if it is necessary to measure the ionisation current, disconnect the plug-socket on the ionisation probe cable and insert a direct current microammeter with a base scale of 100  $\mu\text{A}$ .

Carefully check the polarities!

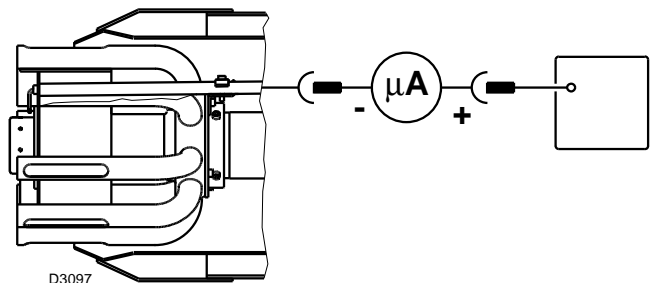

**Fig. 31**

**Gas leaks**

Make sure that there are no gas leaks on the pipes between the gas meter and the burner.

**Gas filter**

Replace the gas filter when it is dirty.

**Combustion**

If the combustion values measured before starting maintenance do not comply with applicable legislation or do not indicate efficient combustion, consult the Tab. K or contact our Technical Support Service to implement the necessary adjustments. It is advisable to set the burner according to the type of gas used and following the indications in Tab. K.

EN 676		Air excess			
		Max. output $\lambda \leq 1.2$		Min. output $\lambda \leq 1.3$	
GAS	CO <sub>2</sub> theoretical al max. 0% O <sub>2</sub>	CO <sub>2</sub> % Calibration		CO	NO <sub>x</sub>
		$\lambda = 1.2$	$\lambda = 1.3$	mg/kWh	mg/kWh
G 20	11.7	9.7	9.0	≤ 100	≤ 170
G 25	11.5	9.5	8.8	≤ 100	≤ 170
G 30	14.0	11.6	10.7	≤ 100	≤ 230
G 31	13.7	11.4	10.5	≤ 100	≤ 230

Tab. K

**7.3 Opening the burner**



Disconnect the electrical supply from the burner by means of the main system switch.



Close the fuel interception tap.



Wait for the components in contact with heat sources to cool down completely.

- Remove the tie-rod 1)(Fig. 32) of the head movement lever, undoing the nut 2).
- Disconnect the socket 3) of the gas servomotor.
- Disconnect the socket 4) of the gas pressure switch.
- Remove the screws 5).

At this point, it is possible to open the burner on the hinge.

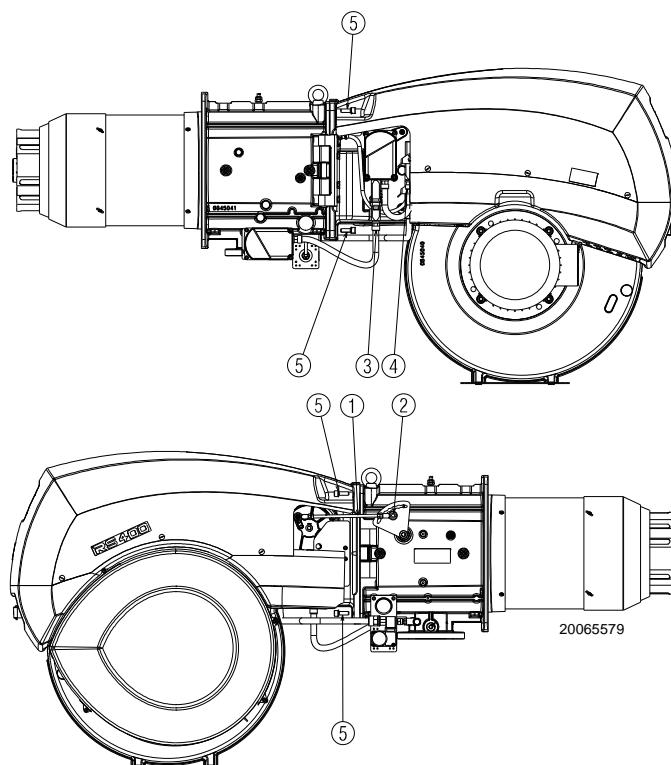

Fig. 32

**7.4 Closing the burner**

Refit following the steps described but in reverse order; refit all burner components as they were originally assembled.



Carry out all maintenance work and mount the casing again.

**8** **Faults - Probable causes - Solutions**

If faults arise in ignition or operations, the burner performs a “safety stop”, which is signalled by the red burner lockout LED.

The display visualises alternately the lockout code and the relative diagnostic. To reset the start-up conditions, refer to the “Reset procedure” indicated in the control box manual supplied.

When the burner starts again, the red LED goes out and the control box is reset.

**WARNING**

In the event of a burner lockout, more than two consecutive burner reset operations could cause damage to the installation. On the third lockout, contact the Aftersales Service.

**DANGER**

If further lockouts or burner faults occur, interventions must only be made by qualified, authorised personnel (as indicated in this manual, and in compliance with the laws and regulations currently in force).



**A Appendix - Accessories****Long head Kit**

Burner	Standard head length (mm)	Extended head length (mm)	Code
RS 300-400/EV BLU	521 (B) - 373 (I)	621 (B) - 473 (I)	3091427
RS 300-400/EV BLU	521 (B) - 373 (I)	671 (B) - 523 (I)	3091919
RS 300-400/EV BLU	521 (B) - 373 (I)	721 (B) - 573 (I)	20022815
RS 500/EV BLU	521 - 357	671 - 507	20028449

For (B) - (I) positions, refer to paragraph "Maximum dimensions".

**Inverter kit (VSD)**

Burner	Max. output (kW)	Code
RS 300/EV BLU	5,5	20081675
RS 400/EV BLU	7,5	20081645
RS 500/EV BLU	11	20081646
RS 650/EV BLU	18,5	20081661
RS 800/EV BLU	22	20081664

**Kit for modulating operation**

Burner	Probe	Adjustment field	Code
All models	PT 100 temperature	- 100...+ 500°C	3010110
All models	4 - 20 mA pressure	0...2.5 bar	3010213
All models	4 - 20 mA pressure	0...16 bar	3010214

**AZL Kit (display and operating unit) - (Russia only)**

Burner	Code
All models	3010469

**Infrared flame detector**

Burner	Code
All models	3010354

**Oxygen control kit (QGO<sub>2</sub>)**

Burner	Code
All models	3010378

**Efficiency kit with oxygen control kit**

Burner	Code
All models	3010377

**Kit software interface (ACS 450)**

---

<b>Burner</b>	<b>Code</b>
All models	3010388

**Soundproofing box kit**

---

<b>Burner</b>	<b>Type</b>	<b>dB(A)</b>	<b>Code</b>
All models	C7	10	3010376

**GPL kit**

---

<b>Burner</b>	<b>Code</b>
RS 300/EV BLU	3010445
RS 400-500/EV BLU	20012916
RS 800/EV BLU	20007822

**Continuous purging kit**

---

<b>Burner</b>	<b>Code</b>
All models	3010094

**Spacer kit**

---

<b>Burner</b>	<b>Code</b>
All models	20008903

**Gas trains in compliance with EN 676**

---

Please refer to manual.

**B Appendix - Electrical panel layout**

<b>1</b>	<b>Index of layouts</b>
<b>2</b>	Indication of references
<b>3</b>	Single-wire output layout
<b>4</b>	LMV52.... functional layout
<b>5</b>	LMV52.... functional layout
<b>6</b>	LMV52.... functional layout
<b>7</b>	LMV52.... functional layout
<b>8</b>	LMV52.... functional layout
<b>9</b>	LMV52.... functional layout Functional layout LMV52.... with O <sub>2</sub> kit
<b>10</b>	LMV52.... functional layout
<b>11</b>	PLL52../QGO20...functional layout PLL52../QGO20... functional layout with O <sub>2</sub> kit
<b>12</b>	Electrical wiring that the installer is responsible for
<b>13</b>	Electrical wiring that the installer is responsible for

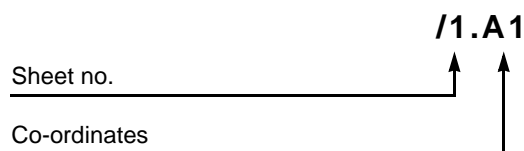
**2 Indication of references**

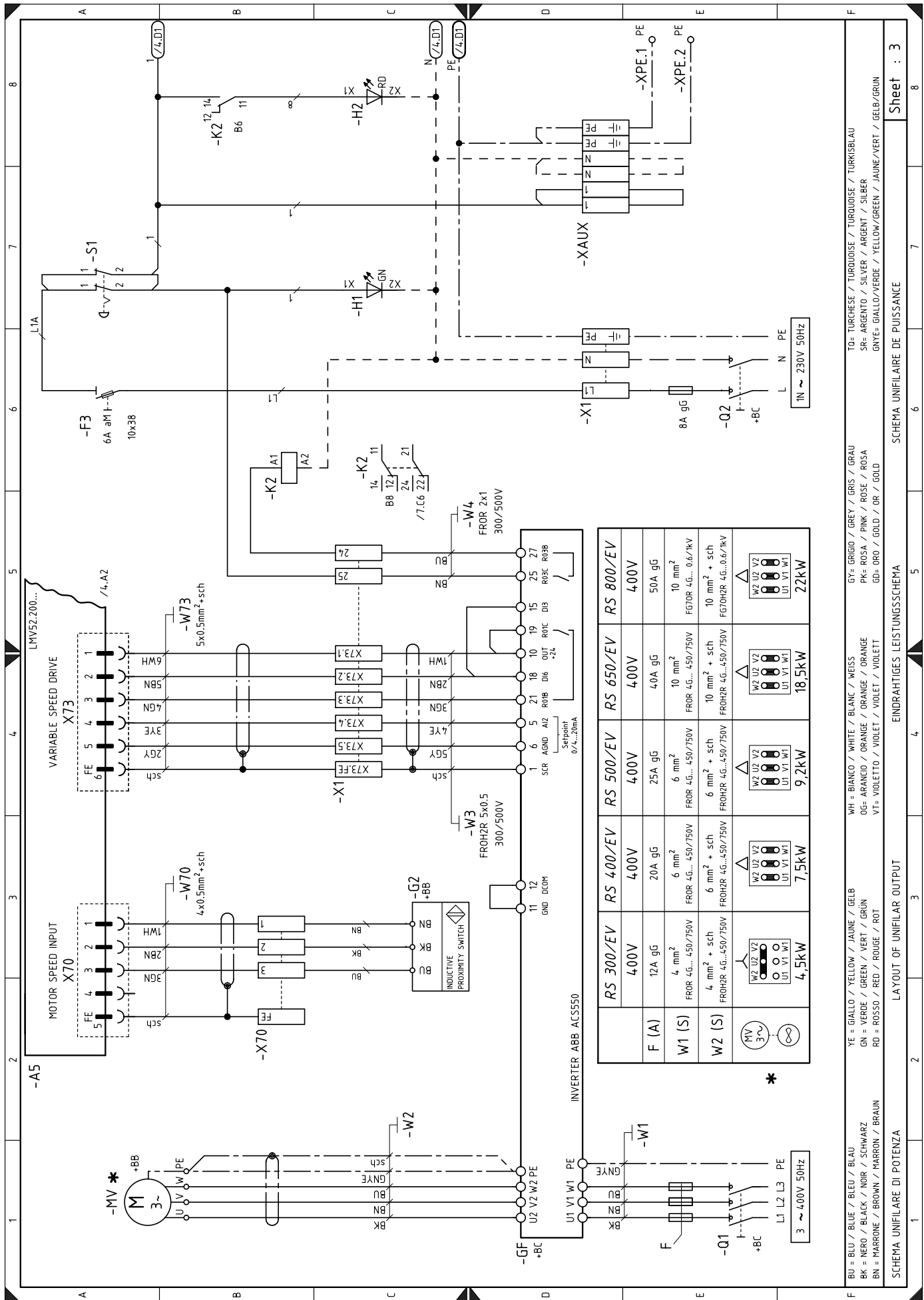

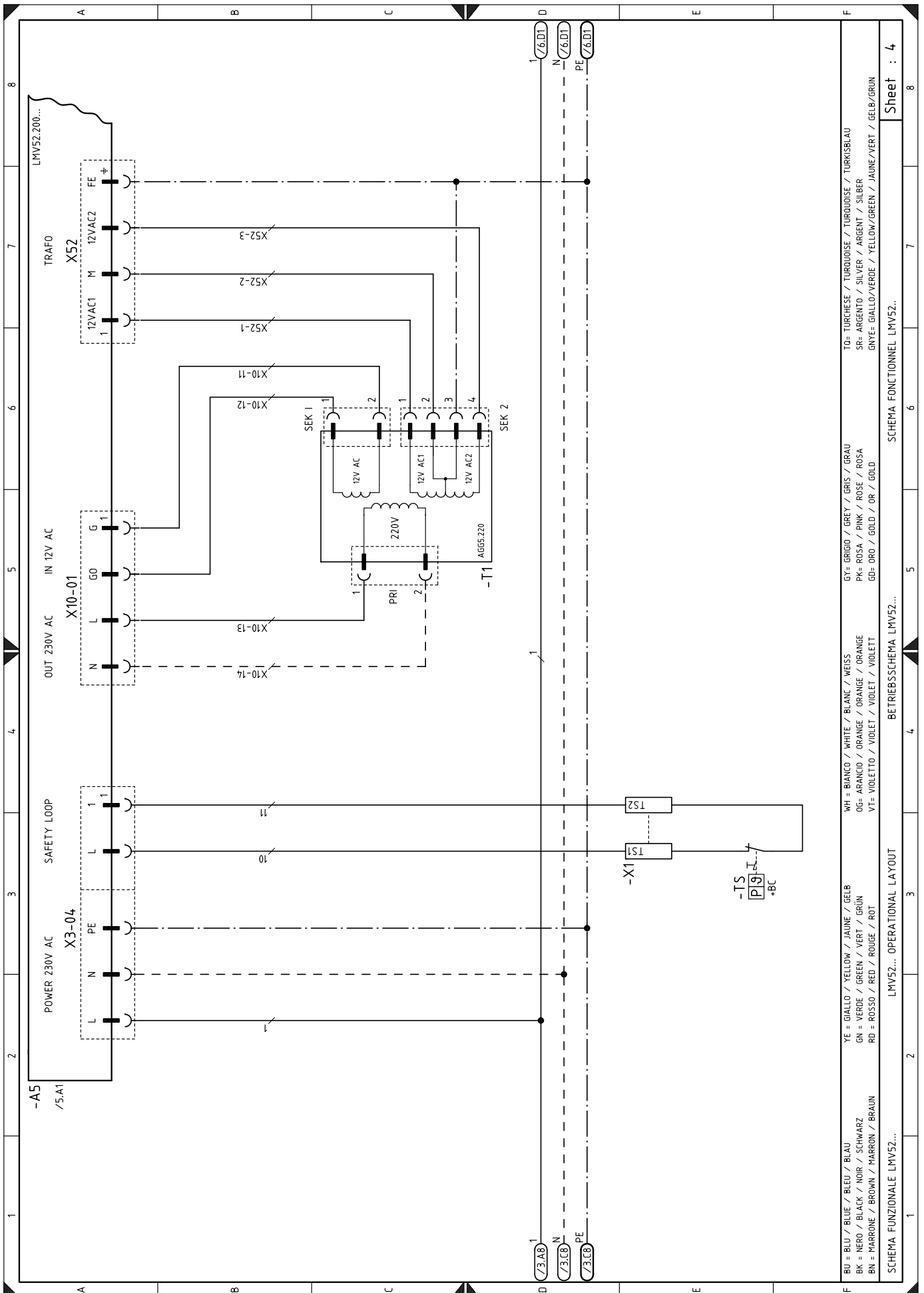

BU = BLU / BLUE / BLEU / BLAU	WH = BIANCO / WHITE / BLANC / WEISS	GY = GRIGIO / GREY / GRIS / GRAU	TO = TURCHESE / TURQUOISE / TURKOISE / TURKISBLAU
BK = NERO / BLACK / NOIR / SCHWARZ	OG = ARANCIO / ORANGE / ORANGE / ORANGE	PK = ROSA / PINK / ROSE / ROSA	SR = ARGENTO / SILVER / ARGENT / SILBER
BN = MARRONE / BROWN / MARRON / BRAUN	VF = VIOLETO / VIOLET / VIOLET / VIOLETT	GD = GRD / GOLD / OR / GOLD	GN = GIALLO / VERDE / YELLOW / GREEN / JAUNE / VERT / GELB / GRÜN

SCHEMA FUNZIONALE LMV52...  
 LMV52... OPERATIONAL LAYOUT  
 BETRIEBSSCHEMA LMV52...  
 SCHEMA FONCTIONNEL LMV52...

Sheet : 4

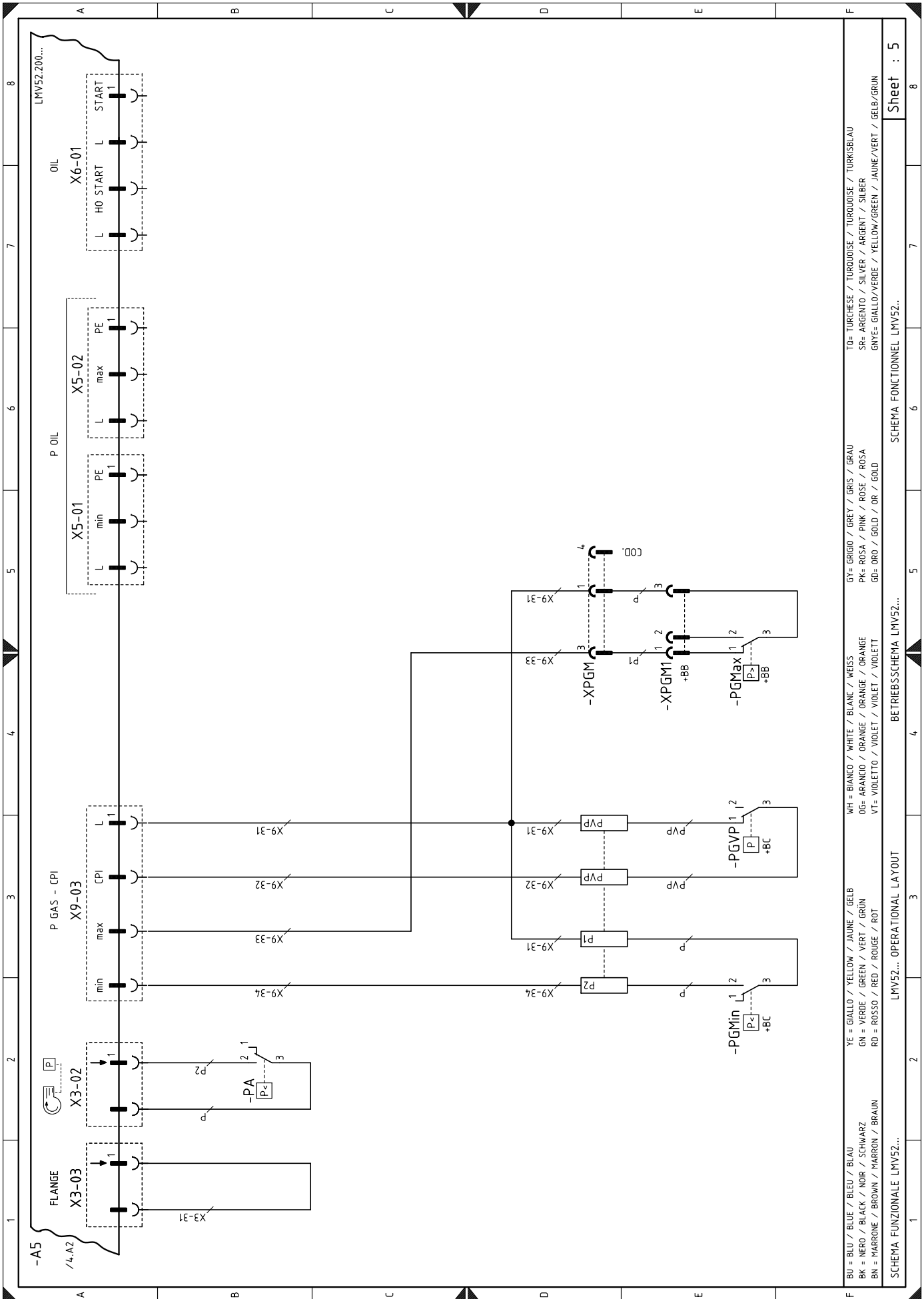

Sheet : 5

SCHEMA FONCTIONNEL LMV52...

BETRIEBSSCHEMA LMV52...

LMV52... OPERATIONAL LAYOUT

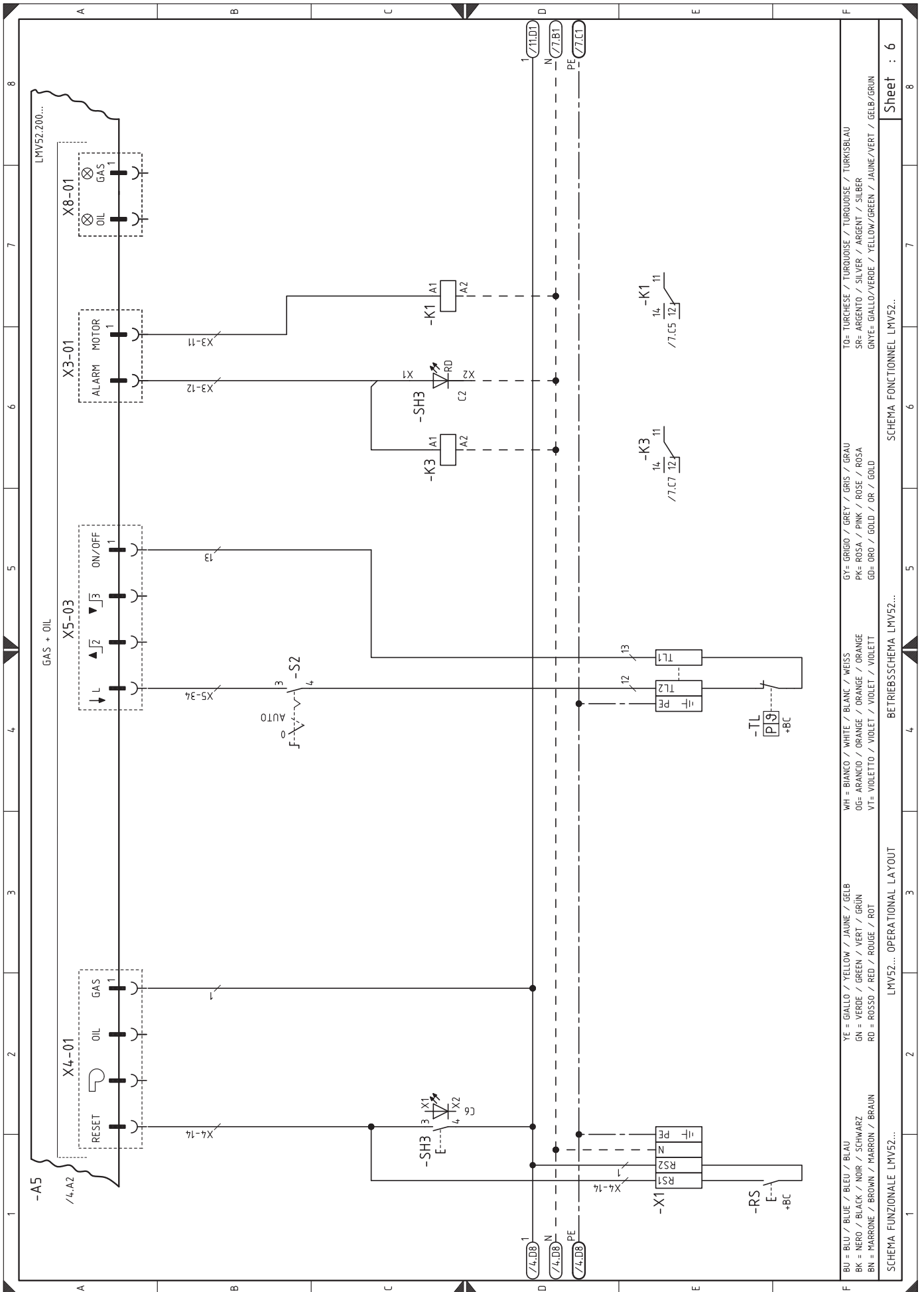

RU = BLU / BLUE / BLEU / BLAU	WH = BIANCO / WHITE / BLANC / WEISS	GY = GRIGIO / GREY / GRIS / GRAU	TO = TURCHESE / TURQUOISE / TURKOISE / TURKISBLAU
BN = NERO / BLACK / NOIR / SCHWARZ	OG = ARANCIO / ORANGE / ORANGE / ORANGE	PK = ROSA / PINK / ROSE / ROSA	SR = ARGENTO / SILVER / ARGENT / SILBER
BN = MARRONE / BROWN / MARRON / BRAUN	VI = VIOLETTA / VIOLET / VIOLET / VIOLETT	GD = ORO / GOLD / OR / GOLD	GN = GIALLO / YELLOW / JAUNE / GELB
			GN = GIALLO / VERDE / YELLOW / GREEN / JAUNE / VERT / GELB / GRÜN

SCHEMA FUNZIONALE LMV52...  
 SCHEMA FONCTIONNEL LMV52...  
 SCHEMA FUNCTIONNEL LMV52...

BETRIEBSSCHEMA LMV52...  
 OPERATIONAL LAYOUT  
 OPERATIONAL LAYOUT

LMV52... OPERATIONAL LAYOUT  
 LMV52... OPERATIONAL LAYOUT  
 LMV52... OPERATIONAL LAYOUT

Sheet : 6

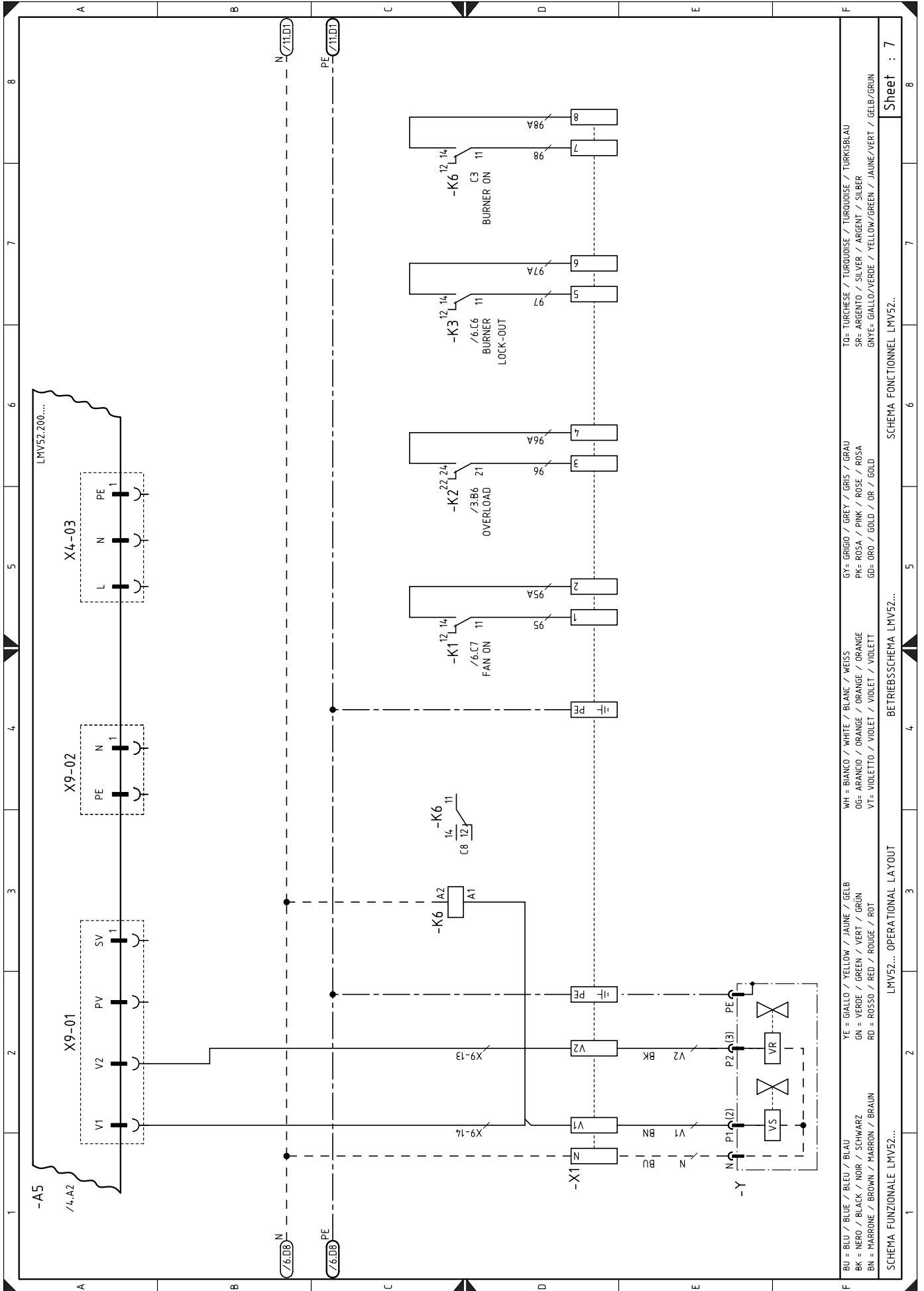

Sheet : 7



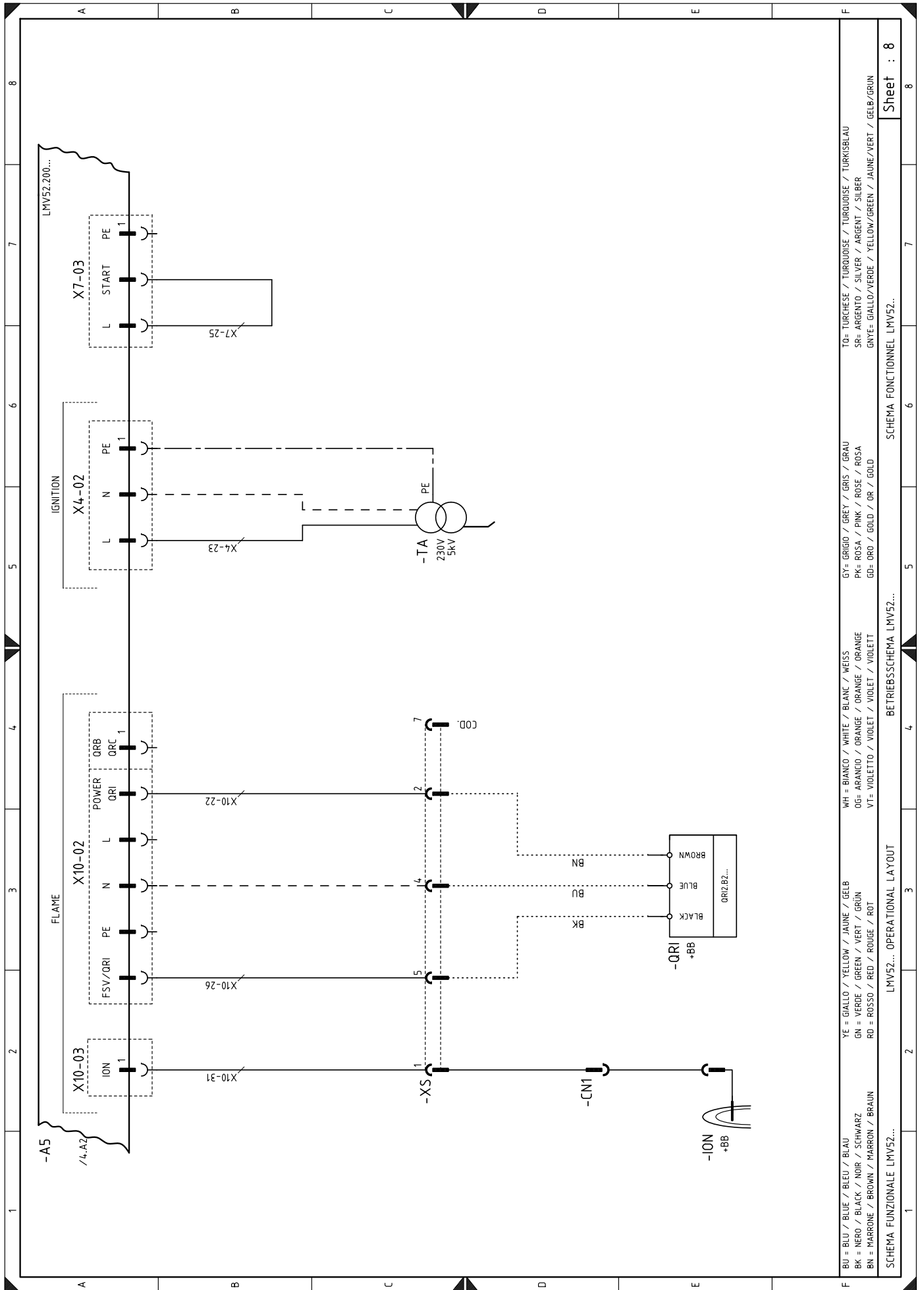

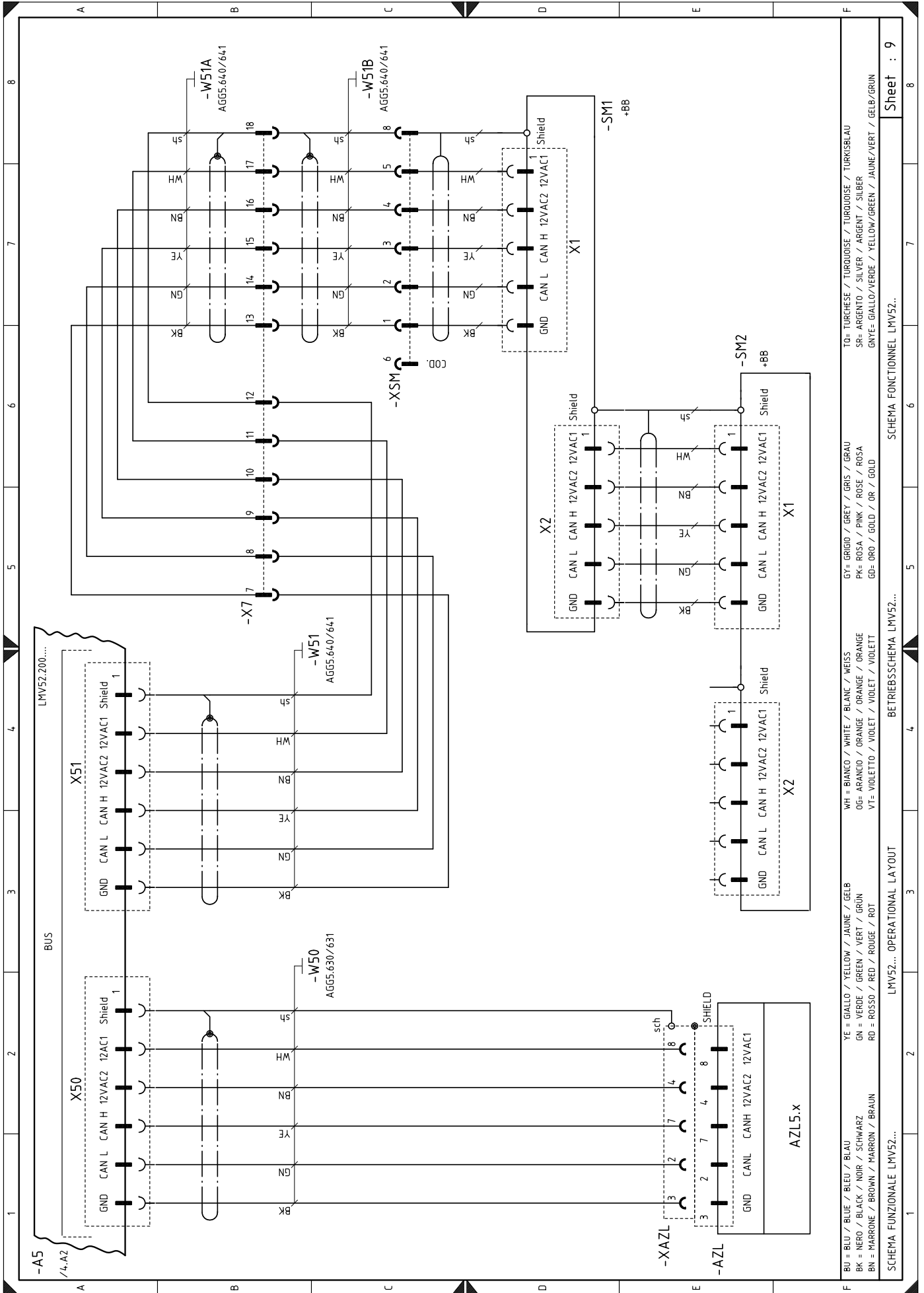

TO= TURCHESE / TURQUOISE / TURQUOISE / TURKISBLAU  
 SR= ARGENTO / SILVER / ARGENT / SILBER  
 GNYE= GIALLO/VERDE / YELLOW/GREEN / JAUNE/VERT / GELB/GRÜN

GY= GRIGIO / GREY / GRIS / GRAU  
 PK= ROSA / PINK / ROSE / ROSA  
 GB= GRU / GOLD / OR / GOLD

WH = BIANCO / WHITE / BLANC / WEISS  
 OG= ARANCIO / ORANGE / ORANGE / ORANGE  
 VT= VIOLETTO / VIOLET / VIOLET / VIOLETT

YE = GIALLO / YELLOW / JAUNE / GELB  
 GN = VERDE / GREEN / VERT / GRÜN  
 RD = ROSSO / RED / ROUGE / ROT

BK = NERO / BLACK / NOIR / SCHWARZ  
 BN = MARRONE / BROWN / MARRON / BRAUN

BU = BLU / BLUE / BLEU / BLAU

LMV52... OPERATIONAL LAYOUT  
 LMV52... BETRIEBSSCHEMA LMV52....  
 SCHEMA FONCTIONNEL LMV52...

Sheet : 9

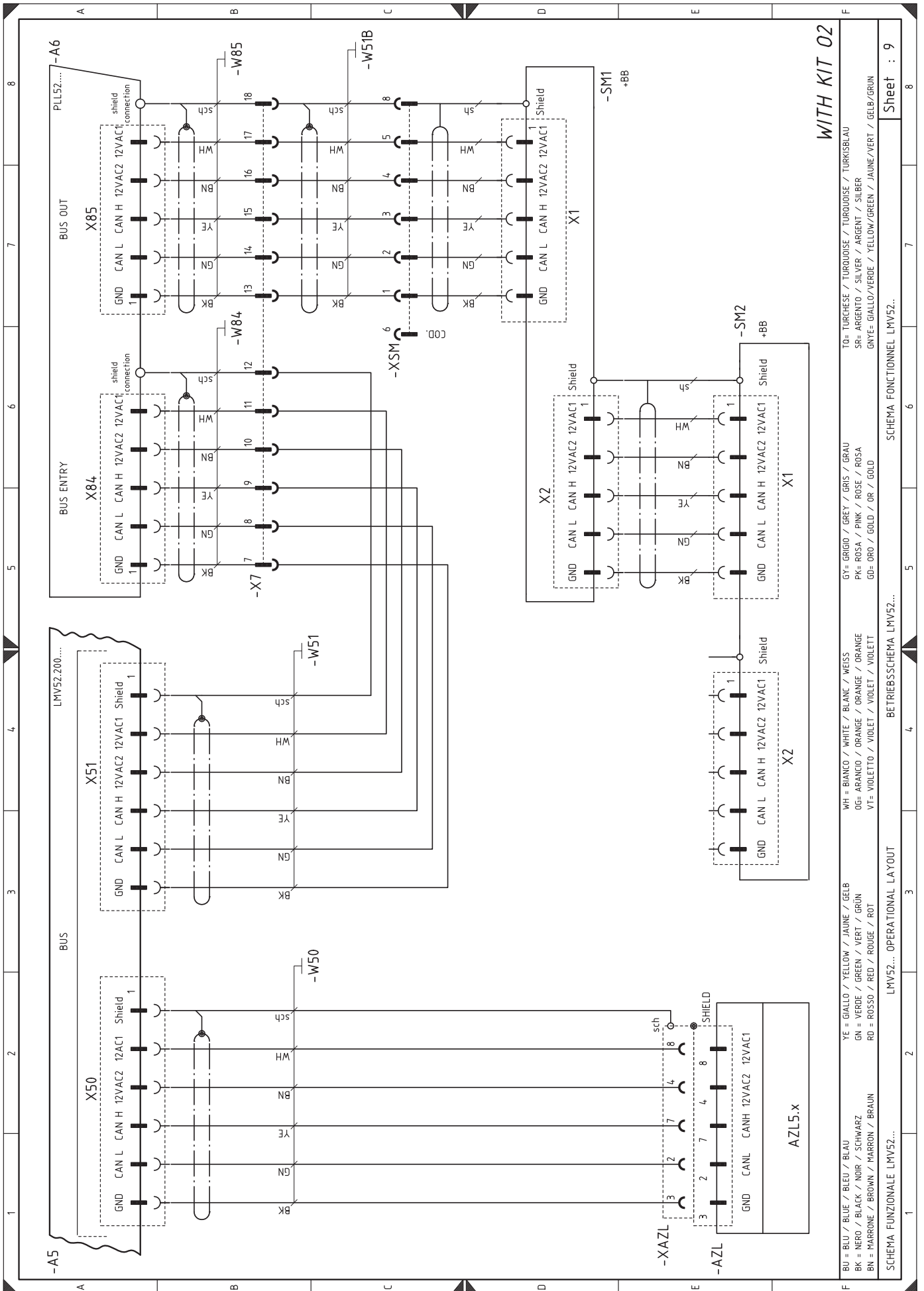

WITH KIT 02

BU = BLU / BLUE / BLEU / BLAU	WH = BIANCO / WHITE / BLANK / WEISS	GY = GRIGIO / GREY / GRIS / GRAU	TO = TURCHESE / TURQUOISE / TURKOISE / TURKISBLAU
BK = NERO / BLACK / NOIR / SCHWARZ	OG = ARANCIO / ORANGE / ORANGE / ORANGE	PK = ROSA / PINK / ROSE / ROSA	SR = ARGENTO / SILVER / ARGENT / SILBER
BN = MARRONE / BROWN / MARRON / BRAUN	VI = VIOLETTA / VIOLET / VIOLET / VIOLETT	GD = ORO / GOLD / OR / GOLD	GNVE = GIALLO/VERDE / YELLOW/GREEN / JAUNE/VERT / GELB/GRÜN

SCHEMA FUNZIONALE LHV52... LHV52... OPERATIONAL LAYOUT BETRIEBSSSCHEMA LHV52... SCHEMA FONCTIONNEL LHV52... SHEET : 9

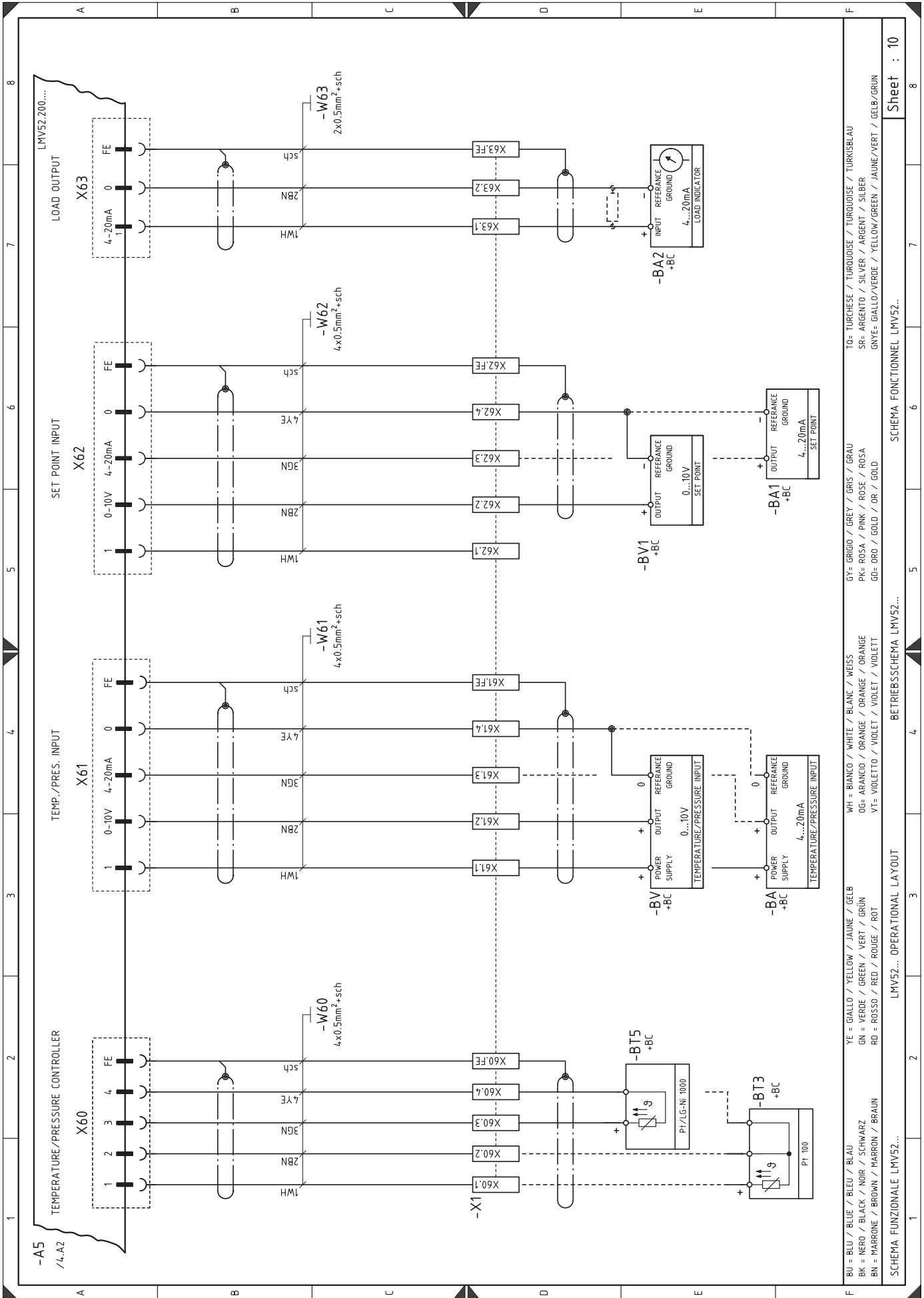

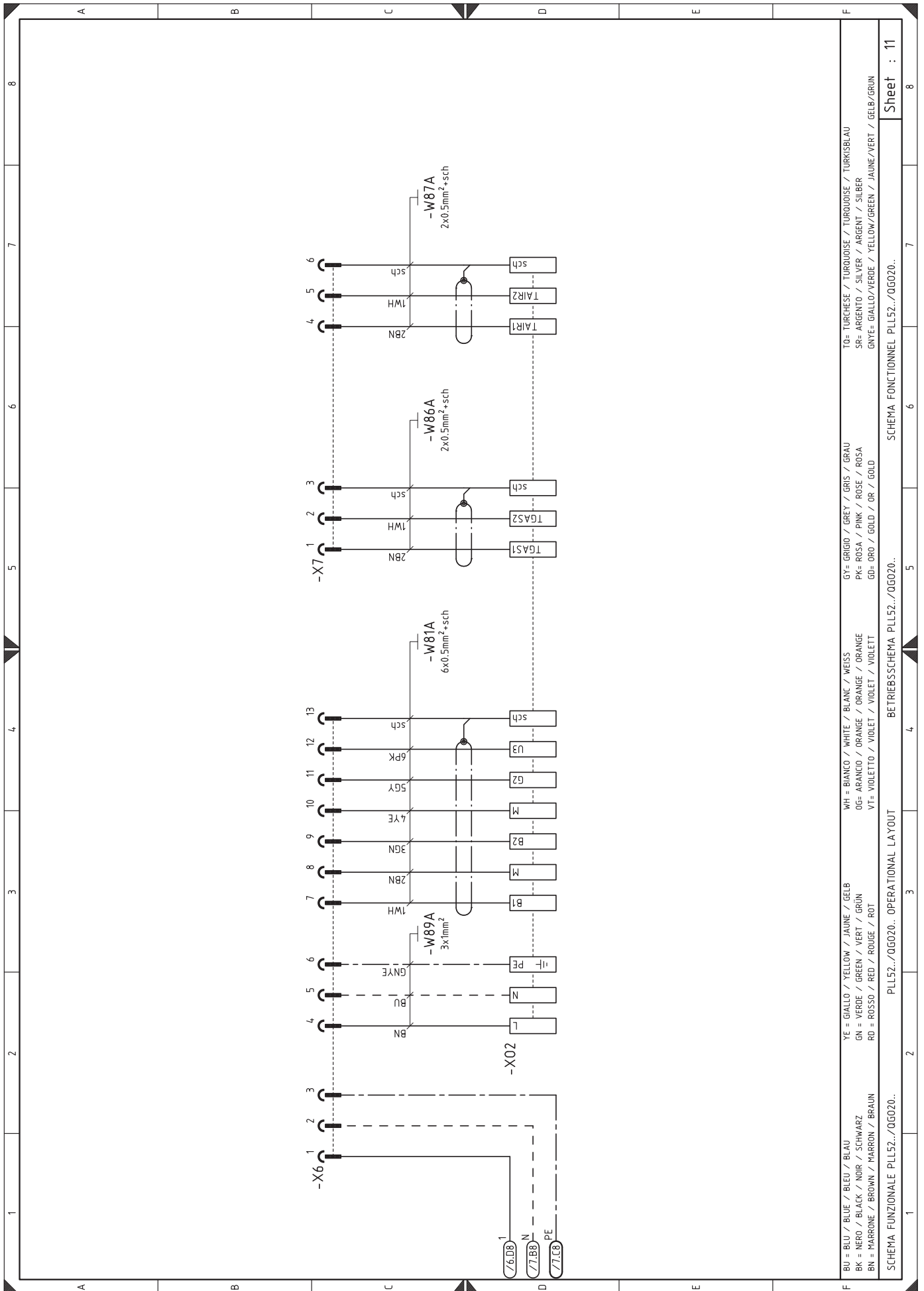

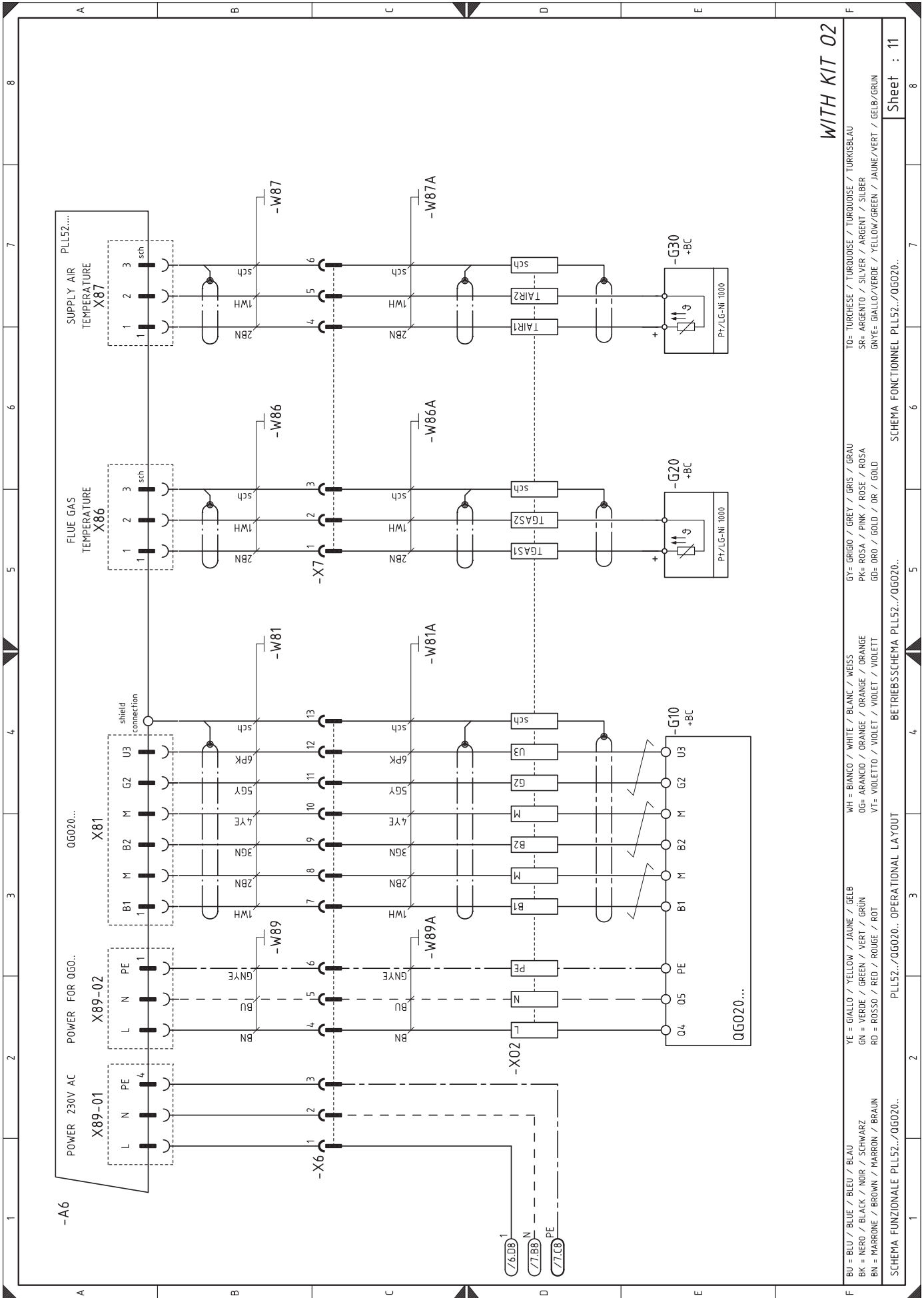

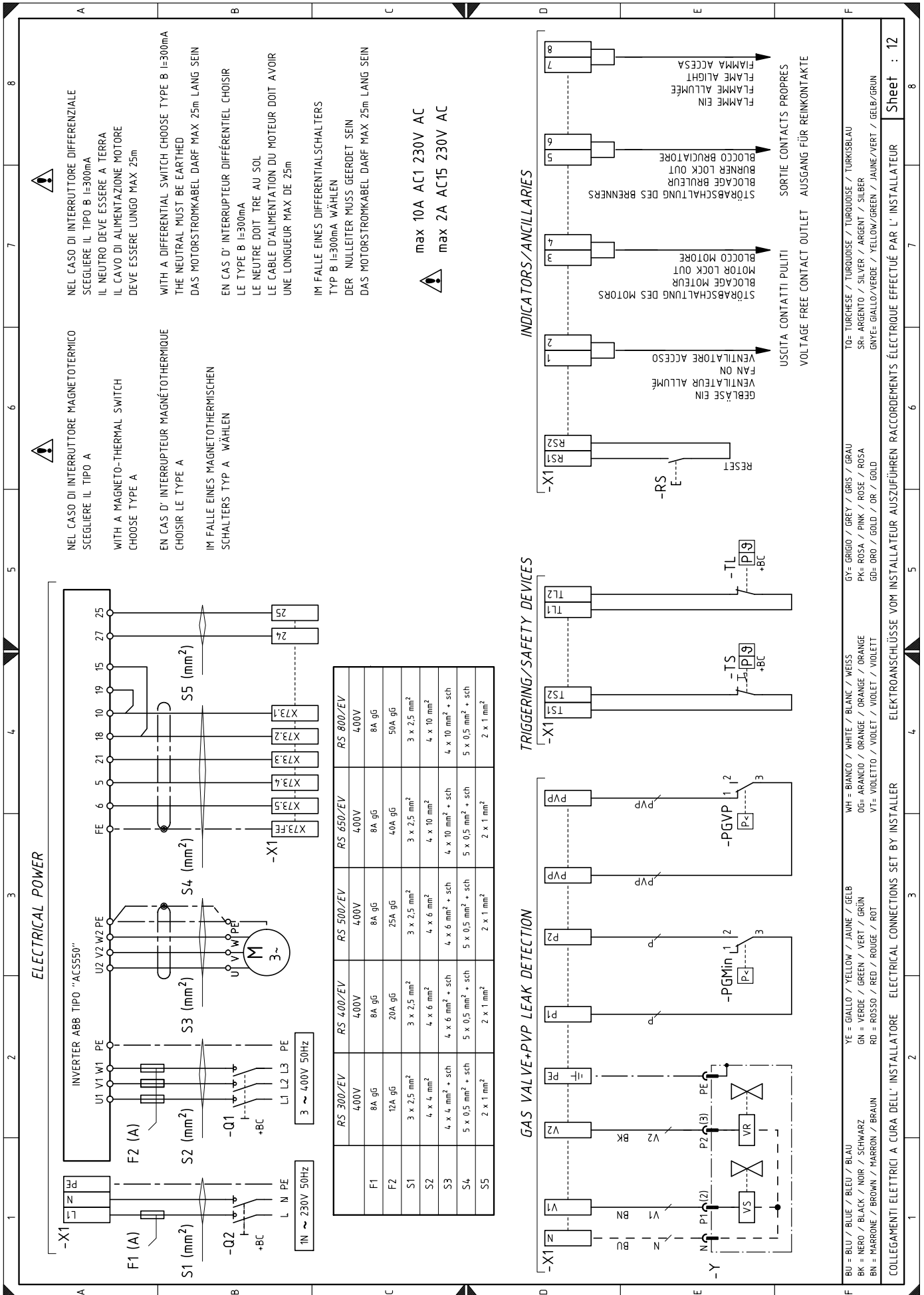

**⚠**

NEL CASO DI INTERRUPTORE MAGNETOTERMICO SCEGLIERE IL TIPO A

WITH A MAGNETO-THERMAL SWITCH CHOOSE TYPE A

EN CAS D' INTERRUPTEUR MAGNÉTO-THERMIQUE CHOISIR LE TYPE A

IM FALLE EINES MAGNETOTHERMISCHEN SCHALTERS TYP A WÄHLEN

**⚠**

NEL CASO DI INTERRUPTORE DIFFERENZIALE SCEGLIERE IL TIPO B I=300mA

IL NEUTRO DEVE ESSERE A TERRA

IL CAVO DI ALIMENTAZIONE MOTORE DEVE ESSERE LUNGO MAX 25m

WITH A DIFFERENTIAL SWITCH CHOOSE TYPE B I=300mA

THE NEUTRAL MUST BE EARTHED

DAS MOTORSTROMKABEL DARF MAX 25m LANG SEIN

EN CAS D' INTERRUPTEUR DIFFÉRENTIEL CHOISIR LE TYPE B I=300mA

LE NEUTRE DOIT ÊTRE AU SOL

LE CABLE D'ALIMENTATION DU MOTEUR DOIT AVOIR UNE LONGUEUR MAX DE 25m

IM FALLE EINES DIFFERENTIALSCHALTERS TYP B I=300mA WÄHLEN

DER NULLEITER MUSS GEEDET SEIN

DAS MOTORSTROMKABEL DARF MAX 25m LANG SEIN

**⚠**

max 10A AC1 230V AC

max 2A AC15 230V AC

**GAS VALVE+PVP LEAK DETECTION**

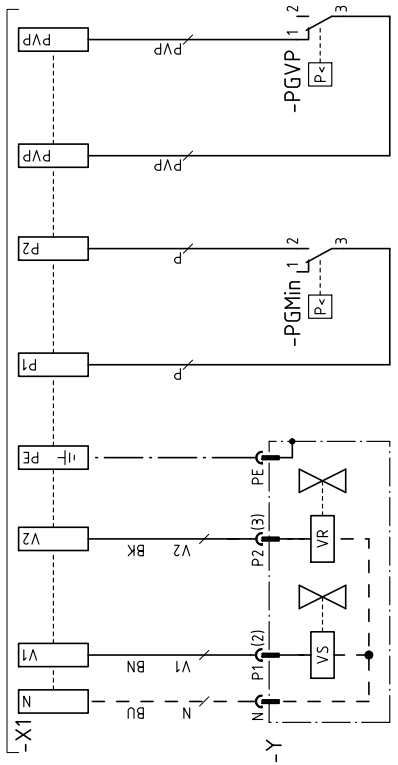

**TRIGGERING/SAFETY DEVICES**

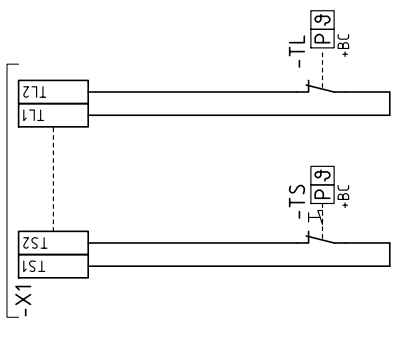

**INDICATORS/ANCILLARIES**

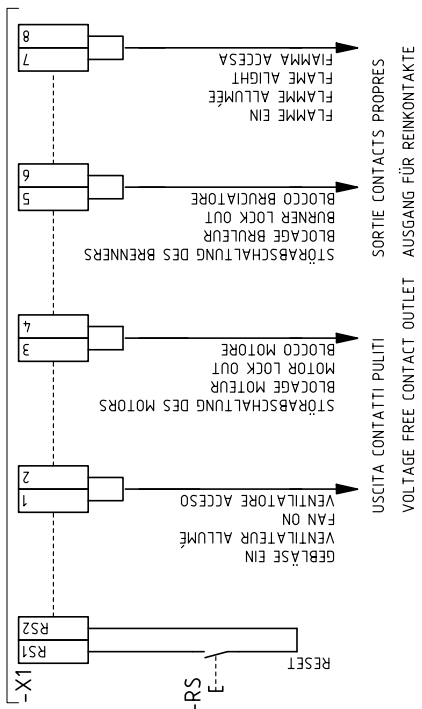

BU = BLU / BLUE / BLEU / BLAU	YE = GIALLO / YELLOW / JAUNE / GELB	WH = BIANCO / WHITE / BLANC / WEISS	GY = GRIGIO / GREY / GRIS / GRAU	TO = TURCHESE / TURQUOISE / TURKOISE / TURKISBLAU
BK = NERO / BLACK / NOIR / SCHWARZ	GN = VERDE / GREEN / VERT / GRÜN	OG = ARANCIO / ORANGE / ORANGE / ORANGE	SR = ARGENTO / SILVER / ARGENT / SILBER	SR = ARGENTO / SILVER / ARGENT / SILBER
BN = MARRONE / BROWN / MARRON / BRAUN	RD = ROSSO / RED / ROUGE / ROT	VI = VIOLETTA / VIOLET / VIOLET / VIOLETT	GNVE = GIALLO/VERDE / YELLOW/GREEN / JAUNE/VERT / GELB/GRÜN	

COLLEGAMENTI ELETTRICI A CURA DELL'INSTALLATORE ELECTRICAL CONNECTIONS SET BY INSTALLER ELEKTROANSCHLÜSSE VOM INSTALLATEUR AUSZUFÜHREN RACCORDEMENTS ÉLECTRIQUE EFFECTUÉ PAR L'INSTALLATEUR

Sheet : 12

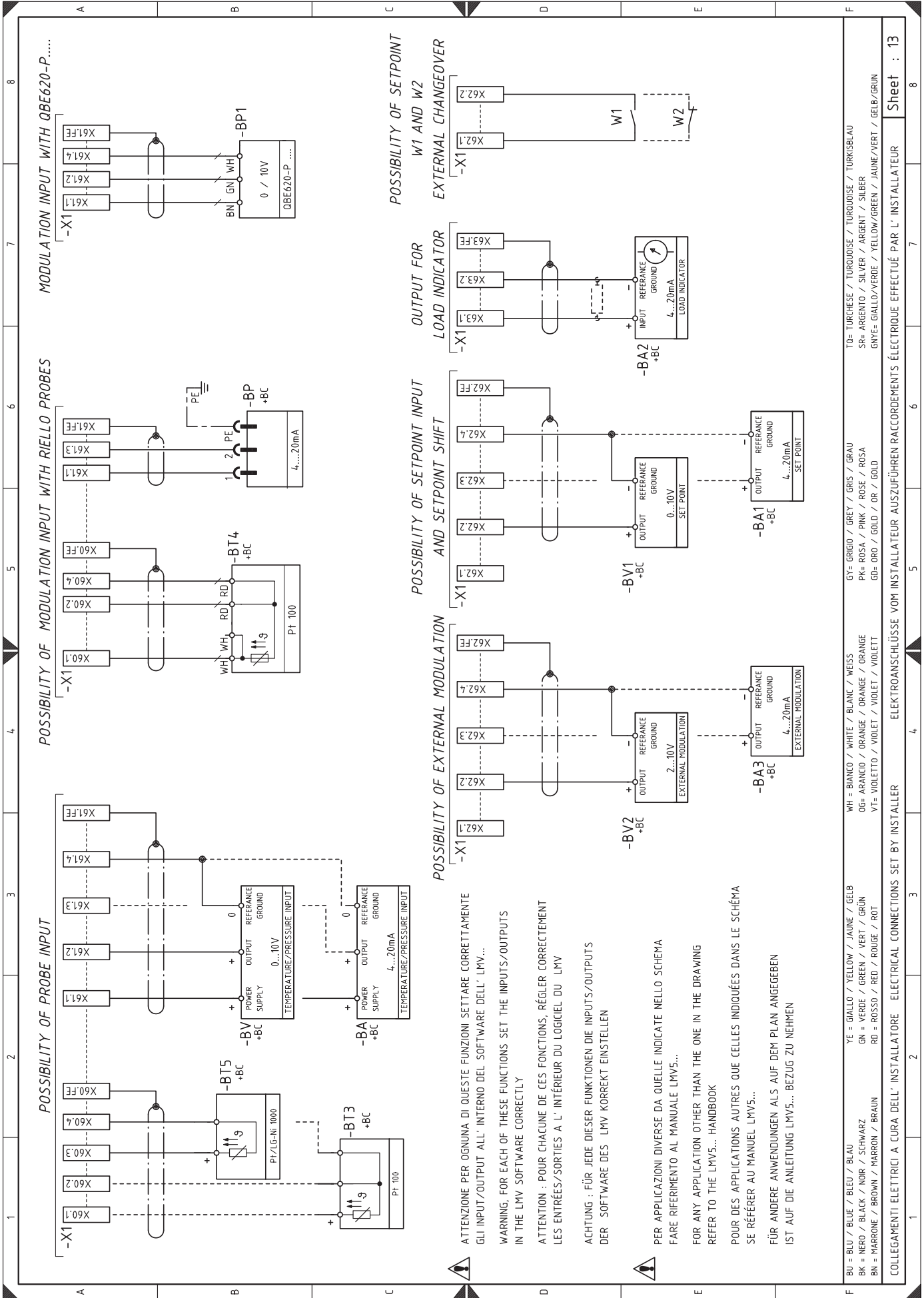



**Wiring layout key**

A5	Electronic cam	XAUX	Auxiliary terminal board
A6	O2 module PLL type..	XAZL	AZL plug on board
AZL	Display and calibration unit	XO2	O2 sensor terminal board
BA	Input in current DC 4...20 mA	XPGM.1	Maximum gas pressure switch connector
BA1	Input in current DC 4...20 mA to modify remote set-point	XS	Flame sensors connector
BA2	Load indicator	XSM	Air and gas servomotor connector
BA3	Input in current DC 4...20 mA		
BP	Pressure probe		
BP1	Pressure probe		
BT3	Probe Pt100, 3 wires		
BT4	Probe Pt100, 3 wires		
BT5	PT/LG-Ni1000 probe		
BV	Input in voltage DC 0...10V		
BV1	Input in voltage DC 0...10V to modify remote setpoint		
CN1	Ionisation probe connector		
F3	Auxiliary fuse		
GF	Inverter		
G2	Rpm sensor (with Inverter kit only)		
G10	O2 sensor OGO20 type..		
G20	Combustion fume temperature sensor probe		
G30	Air temperature control probe		
H1	Light signalling of mains live state		
H2	Fan motor lock-out warning lamp		
ION	Ionisation probe		
K1	Volt-free fan on contacts output relay		
K2	Clean contacts output relay motor lockout		
K3	Clean contacts output relay burner lockout		
K6	Clean contacts output relay burner switched on		
MV	Fan motor		
PA	Air pressure switch		
PE	Burner earth		
PGMax	Maximum gas pressure switch		
PGMin	Minimum gas pressure switch		
PGVP	Gas pressure switch for valve leak detection control device		
QRI	Infrared sensor		
RS	Remote reset button		
S1	Emergency stop button		
S2	Automatic / off selector		
SH3	Burner reset button and light signalling of lock-out signal		
SM1	Air servomotor		
SM2	Gas servomotor		
T1	Electronic cam transformer		
TA	Ignition transformer		
TL	Limit thermostat/pressure switch		
TS	Safety thermostat/pressure switch		
Y	Gas adjustment valve + gas safety valve		
X1	Main terminal supply board		
X6.7	O2 kit plugs-sockets		
X70	RPM sensor terminal board		





---

**RIELLO**

RIELLO S.p.A.  
I-37045 Legnago (VR)  
Tel: +39.0442.630111  
[http:// www.riello.it](http://www.riello.it)  
[http:// www.rielloburners.com](http://www.rielloburners.com)