

- I** Bruciatori di gas ad aria soffiata
- GB** Forced draught gas burners
- F** Brûleurs gaz à air soufflé
- D** Gas-Gebläsebrenner
- E** Quemadores de gas de aire soplado

Funzionamento bistadio
Two-stage operation
Fonctionnement à deux allures
Zweistufiger Betrieb
Funcionamiento de dos llama

CODICE - CODE CÓDIGO	MODELLO - MODEL - MODELE MODELL - MODELO	TIPO - TYPE - TYP
3785814	RS 190	835 T1
20011705	RS 190	835 T1

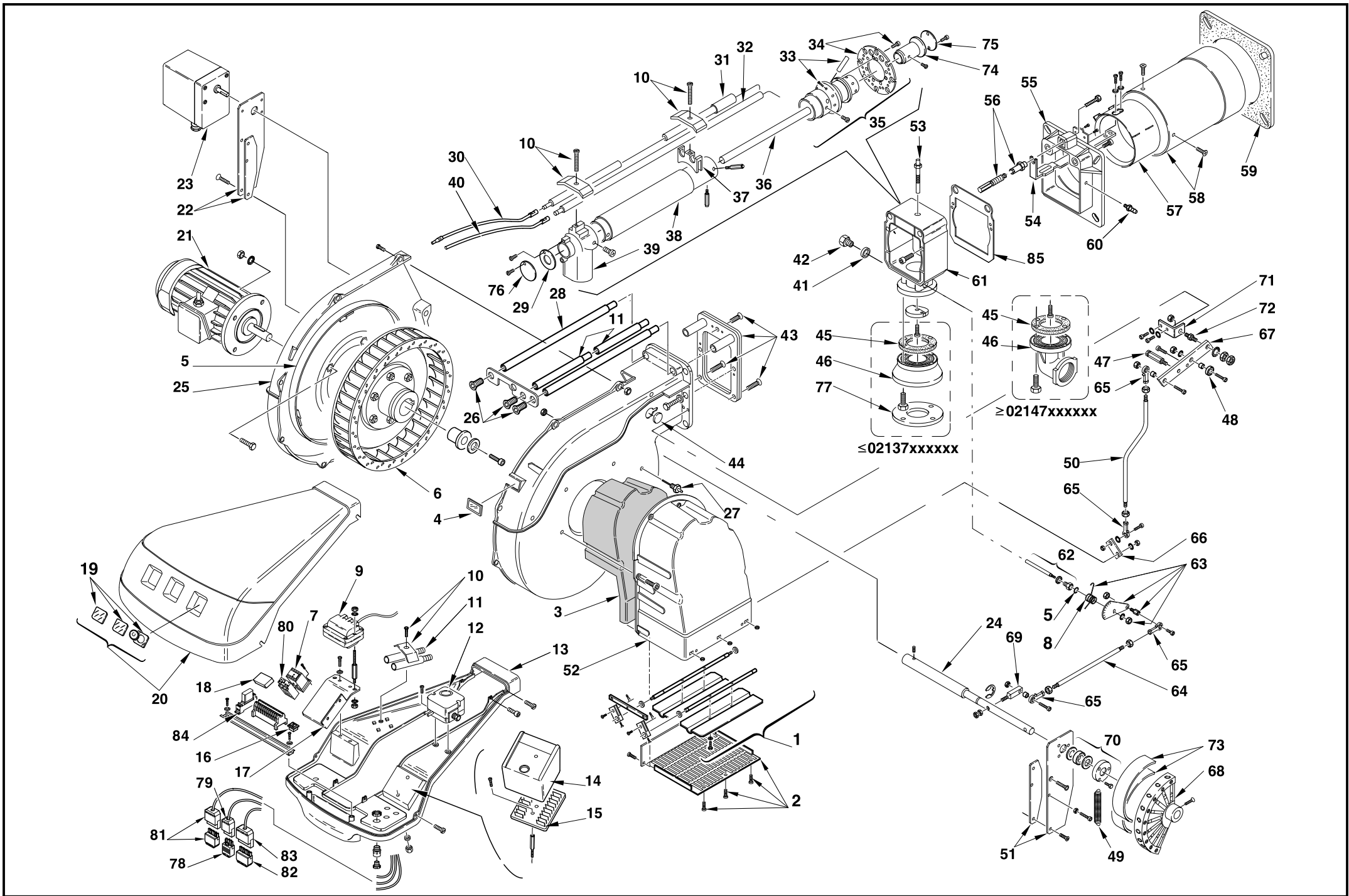

N.	COD.	3785814 20011705	DESCRIZIONE	DESCRIPTION	DESCRIPTION	BESCHREIBUNG	DENOMINACION	MATRICOLA BRUCIATORE BURNER SERIAL NUMBER MATRICULE BRULEUR BRENNER KENN-NUMMER MATRICULA QUEMADORES	*
1	3012583	•	GRUPPO SERRANDA	AIR DAMPER ASSEMBLY	GROUPE VOLET AIR	LUFTKLAPPE	CONJUNTO REGISTRO AIRE	≤ 02406xxxxxx	
1	3013684	•	GRUPPO SERRANDA	AIR DAMPER ASSEMBLY	GROUPE VOLET AIR	LUFTKLAPPE	CONJUNTO REGISTRO AIRE	≥ 02416xxxxxx	
1	3013684	•	GRUPPO SERRANDA	AIR DAMPER ASSEMBLY	GROUPE VOLET AIR	LUFTKLAPPE	CONJUNTO REGISTRO AIRE		
2	3003086	•	PROTEZIONE	GRID	PROTECTION	SCHUTZGITTER	PROTECION	≤ 02406xxxxxx	
2	3013683	•	PROTEZIONE	GRID	PROTECTION	SCHUTZGITTER	PROTECION	≥ 02416xxxxxx	
2	3013683	•	PROTEZIONE	GRID	PROTECTION	SCHUTZGITTER	PROTECION		
3	3012553	•	FONOASSORBENTE	SOUND DAMPING	INSONORISANT	GERÄUSCHDÄMMUNG	AISLAMIENTO ACÚSTICO	≤ 02406xxxxxx	C
3	3013682	•	FONOASSORBENTE	SOUND DAMPING	INSONORISANT	GERÄUSCHDÄMMUNG	AISLAMIENTO ACÚSTICO	≥ 02416xxxxxx	C
3	3013682	•	FONOASSORBENTE	SOUND DAMPING	INSONORISANT	GERÄUSCHDÄMMUNG	AISLAMIENTO ACÚSTICO		C
4	3003763	••	VISORE	INSPECTION WINDOW	WISEUR	SICHTFENSTER	VISOR		
5	3012573	••	ANELLO	PISTON SEAL	JOINT TORIQUE	LIPPENDICHTUNG	ANILLO		
6	3012555	••	GIRANTE	FAN	TURBINE	GEBLÄSERAD	TURBINA		C
7	3003637	•	CONTATTORE	CONTACTOR	CONTACTEUR	SCHÜTZ	CONTACTOR	≤ 02179xxxxxx	C
7	3013978	•	CONTATTORE	CONTACTOR	CONTACTEUR	SCHÜTZ	CONTACTOR	≥ 02189xxxxxx	C
7	3013978	•	CONTATTORE	CONTACTOR	CONTACTEUR	SCHÜTZ	CONTACTOR		C
8	3013204	••	MOLLA	SPRING	RESSORT	FEDER	MUELLE		B
9	3003847	••	TRASFORMATORE	TRANSFORMER	TRANSFORMATEUR	ZÜNDTRANSFORMATOR	TRANSFORMADOR		B
10	3003409	••	CAVALLOTTO	U BOLT	CAVALIER	BÜGELBOLZEN	FIJACION ELECTRODO		
11	3003956	•	PROLUNGA PERNO	BAR EXTENSION	RALLONGE DE GLISSIERE	VERLÄNGERUNG	EXTENSIÓN PERNO	≤ 02406xxxxxx	
11	3013687	•	PROLUNGA PERNO	BAR EXTENSION	RALLONGE DE GLISSIERE	VERLÄNGERUNG	EXTENSIÓN PERNO	≥ 02416xxxxxx	
11	3013687	•	PROLUNGA PERNO	BAR EXTENSION	RALLONGE DE GLISSIERE	VERLÄNGERUNG	EXTENSIÓN PERNO		
12	3007444	••	PRESSOSTATO ARIA	AIR PRESSURE SWITCH	PRESSOSTAT AIR	LUFTDRUCKWÄCHTER	PRESOSTATO DEL AIRE		A
13	3012008	•	MENSOLA	BASE PLATE	PLAQUE DE SUPPORT	GRUNDPLATTE	REPISA	≤ 02188xxxxxx	
13	3014124	•	MENSOLA	BASE PLATE	PLAQUE DE SUPPORT	GRUNDPLATTE	REPISA	≥ 02198xxxxxx	
13	3014124	•	MENSOLA	BASE PLATE	PLAQUE DE SUPPORT	GRUNDPLATTE	REPISA		
14	3013073	••	APPARECCHIATURA	CONTROL BOX	BOITE DE CONTROLE	STEUERGERÄT	CAJA CONTROL		B
15	3003784	••	MORSETTIERA	CONTROL BOX BASE	SOCLE	STECKSOCKEL	ZOCALO CAJA CONTROL		C
16	3003770	••	INTERRUTTORE	SWITCH	INTERRUPTEUR	SCHALTER	INTERUCTOR		C
17	3003957	•	SUPPORTO	SUPPORT	SUPPORT	HALTER	CORCHETE	≤ 02179xxxxxx	
18	3012155	••	FILTRO ANTIDISTURBO	DEGLITCHER	FILTRE	ENTSTÖRER	FILTRO ANTI-INTERFEREN- CIA		C
19	3013678	••	MEMBRANA + VETRINO	MEMBRANE+VIEWING PORT	MEMBRANE+REGARD	MEMBRAN+VERSCHLUßS- TOPFEN	MEMBRANA+MIRILLA		
20	3013119	••	COFANO	COVER	COFFRET	VERKLEIDUNG	ENVOLVENTE		
21	20050960	••	MOTORE	MOTOR	MOTEUR	MOTOR	MOTOR		C

N.	COD.	3785814 20011705	DESCRIZIONE	DESCRIPTION	DESCRIPTION	BESCHREIBUNG	DENOMINACION	MATRICOLA BRUCIATORE BURNER SERIAL NUMBER MATRICULE BRULEUR BRENNER KENN-NUMMER MATRICULA QUEMADORES	*
22	3012585	• •	PIASTRA	ANCHOR PLATE	PLATINE DE BLOCAGE	ARRETIERPLATTE	PLACA		
23	3012586	• •	SERVOMOTORE	SERVOMOTOR	SERVOMOTEUR	STELLMOTOR	SERVOMOTOR		B
24	3012349	• •	ALBERO	SHAFT	ARBRE	WELLE	ARBOLILLO		
25	3012587	• •	GUSCIO	HALF-SHELL	COUVERCLE	HAUBE	CÀSCARA		
26	3003481	•	VITE	SCREW	VIS	SCHRAUBE	TORNILLO	≤ 02406xxxxxx	
26	3013681	•	VITE	SCREW	VIS	SCHRAUBE	TORNILLO	≥ 02416xxxxxx	
26	3013681	•	VITE	SCREW	VIS	SCHRAUBE	TORNILLO		
27	3003891	• •	RACCORDO	CONNECTOR	MAMELON	NIPPEL	RACORD		C
28	3012013	•	PERNO	BAR	GLISSIERE	BOLZEN	PERNO	≤ 02406xxxxxx	C
29	3012588	• •	DISCO	DISC	DISQUE	SCHEIBE	TUBO LLAMA		
30	3003795	• •	COLLEGAMENTO ELET- TRODO	H.T. LEAD	CONNEXION POUR ELEC- TRODE	VERBINDUNG FÜR ELE- KTRODE	CABLE ELECTRODO		A
31	3012016	• •	ELETTRODO	ELECTRODE	ELECTRODE PORCELAINE	ELEKTRODE	ELECTRODO		A
32	3012178	• •	SONDA	PROBE	SONDE	FÜHLER	SONDA		A
33	3012025	• •	TUBETTO	TUBE	TUYAU	RÖHRCHEN	TUBITO		
34	3012027	• •	DISCO	DISC	DISQUE	SCHEIBE	TUBO LLAMA		A
35	3012589	• •	DISTRIBUTORE	GAS HEAD	DISTRIBUTEUR	GASVERTEILER	DISTRIBUIDOR		
36	3012590	• •	TUBO INTERNO	INTERIOR TUBE	TUYAU INTERIEUR	INNERER ROHR	TUBO INTERNO		
37	3012193	• •	SUPPORTO	SUPPORT	SUPPORT	HALTER	CORCHETE		
38	3012591	• •	TUBO ESTERNO	EXTERIOR TUBE	TUYAU EXTERIEUR	AUSSERER ROHR	TUBO EXTERNO		
39	3012042	• •	GOMITO	ELBOW	COUDE	SCHLITTEN	DISCO		
40	3012043	• •	COLLEGAMENTO SONDA	PROBE LEAD	CONNEXION POUR SONDE	VERBINDUNG FÜR SONDE	CABLE SONDA DE IONIZA- CIÓN		A
41	3007088	• •	GUARNIZIONE	SEAL	RONDELLE	METALLDICHTUNG	JUNTA		B
42	3003863	• •	TAPPO	PLUG	BOUCHON A VIS	SCHRAUBSTÖPSEL	TAPÓN		
43	3013685	•	GRUPPO PIASTRE	PLATES ASSEMBLY	GROUPE PLATINES	PLATTEN GROUPE	CONJUNTO PLACAS	≥ 02416xxxxxx	
43	3013685	•	GRUPPO PIASTRE	PLATES ASSEMBLY	GROUPE PLATINES	PLATTEN GROUPE	CONJUNTO PLACAS		
44	3003996	• •	TAPPO	PLUG	BOUCHON A VIS	SCHRAUBSTÖPSEL	TAPÓN		
45	3005482	• •	GUARNIZIONE	SEAL	RONDELLE	METALLDICHTUNG	JUNTA		B
46	3006803	•	FLANGIA E GOMITO	FLANGE AND ELBOW	BRIDE ET COUDE	ANSCHLUSSFLANSCH UND GASVERTEILER	BRIDA Y CODO	≥ 02147xxxxxx	
46	3006803	•	FLANGIA E GOMITO	FLANGE AND ELBOW	BRIDE ET COUDE	ANSCHLUSSFLANSCH UND GASVERTEILER	BRIDA Y CODO		
46	3012592	•	FLANGIA	FLANGE	BRIDE	ANSCHLUSSFLANSCH	BRIDA	≤ 02137xxxxxx	
47	3012352	• •	PERNO	BAR	GLISSIERE	BOLZEN	PERNO		C
48	3003841	• •	CUSCINETTO	BEARING	ROULEMENT	LAGER	COJINETE		

N.	COD.	3785814 20011705	DESCRIZIONE	DESCRIPTION	DESCRIPTION	BESCHREIBUNG	DENOMINACION	MATRICOLA BRUCIATORE BURNER SERIAL NUMBER MATRICULE BRULEUR BRENNER KENN-NUMMER MATRICULA QUEMADORES	*
49	3012356	• •	MOLLA	SPRING	RESSORT	FEDER	MUELLE		
50	3012646	• •	TIRANTE	TIE ROD	TIRANT	GESTÄNGE	TIRANTE		C
51	3012594	• •	PIASTRA	ANCHOR PLATE	PLATINE DE BLOCAGE	ARRETIERPLATTE	PLACA		
52	3012595	•	BOCCA D'ASPIRAZIONE	AIR INTAKE	BOITIER D'ASPIRATION	ANSAUGÖFFNUNG	BOCA ASPIRACION	≤ 02406xxxxxx	
53	3012049	• •	VITE	SCREW	VIS	SCHRAUBE	TORNILLO		
54	3013698	•	SQUADRETTA	SQUARE	EQUERRE - SUPPORT	HALTER	ESCUADRA	≥ 02416xxxxxx	
54	3013698	•	SQUADRETTA	SQUARE	EQUERRE - SUPPORT	HALTER	ESCUADRA		
55	3012559	•	FRONTONE	FRONT PIECE	FACADE	VORDERTEIL	TUBO LLAMA	≤ 02406xxxxxx	
56	3013291	•	GRUPPO REGOLATORE	CONTROL DEVICE	GROUPE OBTURATION	DRUCKREGULIERUNG	GRUPO REGULACION	≤ 02406xxxxxx	
56	3012639	•	GRUPPO REGOLATORE	CONTROL DEVICE	GROUPE OBTURATION	DRUCKREGULIERUNG	GRUPO REGULACION	≥ 02416xxxxxx	C
56	3012639	•	GRUPPO REGOLATORE	CONTROL DEVICE	GROUPE OBTURATION	DRUCKREGULIERUNG	GRUPO REGULACION		C
57	3012560	• •	OTTURATORE	SHUTTER	OBTURATEUR	SCHIEBER	OBTURADOR		C
58	3012596	•	IMBUTO FIAMMA	END CONE	EMBOUT GUEULARD	FLAMMENROHR	TUBO EXTREMO	≤ 02406xxxxxx	B
58	3013699	•	IMBUTO FIAMMA	END CONE	EMBOUT GUEULARD	FLAMMENROHR	TUBO EXTREMO	≥ 02416xxxxxx	
58	3013699	•	IMBUTO FIAMMA	END CONE	EMBOUT GUEULARD	FLAMMENROHR	TUBO EXTREMO		
59	3012562	• •	SCHERMO	FLANGE GASKET	ECRAN THERMIQUE	FLASCHDICHTUNG	JUNTA AISLANTE		A
60	3003322	• •	RACCORDO	CONNECTOR	MAMELON	NIPPEL	RACORD		C
61	3012597	•	MANICOTTO	MANIFOLD	MANCHON	GASANSCHLUSS	MANGUITO	≤ 02382000584	
61	3013166	•	MANICOTTO	MANIFOLD	MANCHON	GASANSCHLUSS	MANGUITO	≥ 02382000585; ≤ 02406xxxxxx	
62	3012598	• •	ALBERO MANICOTTO	BUTTERFLY VALVE SHAFT	AXE DE LA VANNE PAPILLON	SPINDEL GASDROSSEL	ARBORILLO MANGUITO		
63	3012599	• •	QUADRANTE	GRADUATE SECTOR	SECTEUR GRADUE	SKALENSEGMENT	CUADRANTE		
64	3012600	•	TIRANTE	TIE ROD	TIRANT	GESTÄNGE	TIRANTE	≤ 02406xxxxxx	C
64	3013897	•	TIRANTE	TIE ROD	TIRANT	GESTÄNGE	TIRANTE	≥ 02416xxxxxx	C
64	3013897	•	TIRANTE	TIE ROD	TIRANT	GESTÄNGE	TIRANTE		C
65	3006098	• •	SNODO SFERICO	PIN JOINT	CHAPE A ROTULE	KUGELGELENK	ARTICOLACION ESFERICA		C
66	3012601	• •	LEVA	LEVER	LEVIER	HEBEL	PALANCA		C
67	3012354	• •	LEVA	LEVER	LEVIER	HEBEL	PALANCA		C
68	3012358	• •	CAMMA	CAM	CAME	NOCKEN	EXCÉNTRICO		C
69	3012350	• •	LEVA	LEVER	LEVIER	HEBEL	PALANCA		C
70	3012357	• •	CUSCINETTO	BEARING	ROULEMENT	LAGER	COJINETE		
71	3012602	• •	SUPPORTO	SUPPORT	SUPPORT	HALTER	CORCHETE		
72	3012603	• •	PERNO	BAR	GLISSIERE	BOLZEN	PERNO		C
73	3006097	• •	MOLLA	SPRING	RESSORT	FEDER	MUELLE		A

N.	COD.	3785814 20011705	DESCRIZIONE	DESCRIPTION	DESCRIPTION	BESCHREIBUNG	DENOMINACION	MATRICOLA BRUCIATORE BURNER SERIAL NUMBER MATRICULE BRULEUR BRENNER KENN-NUMMER MATRICULA QUEMADORES	*
74	3012604	• •	DIFFUSORE GAS	NOZZLE	DIFFUSEUR	GAS VERTEILER	DIFUSOR		
75	3012605	• •	DISCO	DISC	DISQUE	SCHEIBE	TUBO LLAMA		
76	3012606	• •	DISCO	DISC	DISQUE	SCHEIBE	TUBO LLAMA		B
77	3006589	•	GUARNIZIONE	SEAL	RONDELLE	METALLDICHTUNG	JUNTA	≤ 02137xxxxxx	
78	3006948	• •	SPINA 4 POLI	4 POLE PLUG	FICHE 4 POLES	STECKER 4 POLEN	CONEC.HEMBRA DE 4 CONTA.		
79	3006949	• •	PRESA 4 POLI	4 POLE SOCKET	PRISE 4 POLES	STECKERBUCHSE 4 POLE.	CONEC.MACHO DE 4 CONTA.		
80	3013676	•	RELE' TERMICO	THERMAL OVERLOAD	RELAIS THERMIQUE	ÜBERSTROMAUSLÖSER	RÉLE TÉRMICO	≤ 02179xxxxxx	C
80	3013980	•	RELE' TERMICO	THERMAL OVERLOAD	RELAIS THERMIQUE	ÜBERSTROMAUSLÖSER	RÉLE TÉRMICO	≥ 02189xxxxxx	C
80	3013676	•	RELE' TERMICO	THERMAL OVERLOAD	RELAIS THERMIQUE	ÜBERSTROMAUSLÖSER	RÉLE TÉRMICO		C
81	3013202	• •	SPINA - PRESA A 6 POLI	6 POLE PLUG - SOCKET	FICHE - PRISE 6 POLES	STECK. - STECKERBUCHSE 6 POLEN	CONEC. MACHO-HEMBRA DE 6 CONTAC.		
82	3006938	• •	PRESA 7 POLI	7 POLE SOCKET	PRISE 7 POLES	STECKERBUCHSE 7 POLE.	CONEC.MACHO DE 7 CONTA.		
83	3006937	• •	SPINA 7 POLI	7 POLE PLUG	FICHE 7 POLES	STECKER 7 POLEN	CONEC.HEMBRA DE 7 CONTA.		
84	3013407	•	RELE' TERMICO	THERMAL OVERLOAD	RELAIS THERMIQUE	ÜBERSTROMAUSLÖSER	RÉLE TÉRMICO	≥ 02195000418	C
84	3013407	•	RELE' TERMICO	THERMAL OVERLOAD	RELAIS THERMIQUE	ÜBERSTROMAUSLÖSER	RÉLE TÉRMICO		C
85	3013856	•	GUARNIZIONE	SEAL	RONDELLE	METALLDICHTUNG	JUNTA	≥ 02416xxxxxx	B
85	3013856	•	GUARNIZIONE	SEAL	RONDELLE	METALLDICHTUNG	JUNTA		B

★

RICAMBI CONSIGLIATI - ADVISED PARTS - RECHANGE CONSEIL - EMPFOHLENE ERSATZTEILE - RECAMBIOS ACONSEJADOS

A = Ricambi per dotazione minima - Spare parts for minimum fittings - Pièces détachées pour équipement minimum - Ersatzteile für minimale Ausstattung - Recambios para equipamiento mínimo

A+B = Ricambi per dotazione base di sicurezza - Spare parts for basic safety fittings - Pièces détachées pour équipement standard de sécurité - Ersatzteile für Sicherheitsgrundausrüstung - Recambios para equipamiento básico de seguridad

A+B+C = Ricambi per dotazione estesa di sicurezza - Spare parts for extended safety fittings - Pièces détachées pour équipement complet de sécurité - Ersatzteile für erweiterte Sicherheitsausstattung - Recambios para equipamiento general de seguridad

RIELLO

RIELLO S.p.A.
I-37045 Legnago (VR)
Tel.: +39.0442.630111
[http:// www.riello.it](http://www.riello.it)
[http:// www.rielloburners.com](http://www.rielloburners.com)