

- I** Bruciatori di gas ad aria soffiata
- GB** Forced draught gas burners
- F** Brûleurs gaz à air soufflé
- D** Gas-Gebläsebrenner
- E** Quemadores de gas de aire soplado

Funzionamento bistadio progressivo o modulante
Progressive two-stage or modulating operation
Fonctionnement à 2 allures progressives ou modulant
Gleitend-zweistufiger oder modulierender Betrieb
Funcionamiento a dos llamas progresivas o modulante

CODICE - CODE CÓDIGO	MODELLO - MODEL - MODELE MODELL - MODELO	TIPO - TYPE - TYP
20038459 - 20038484	RS 55/M BLU	832 T
20038482 - 20038486	RS 55/M BLU	832 T

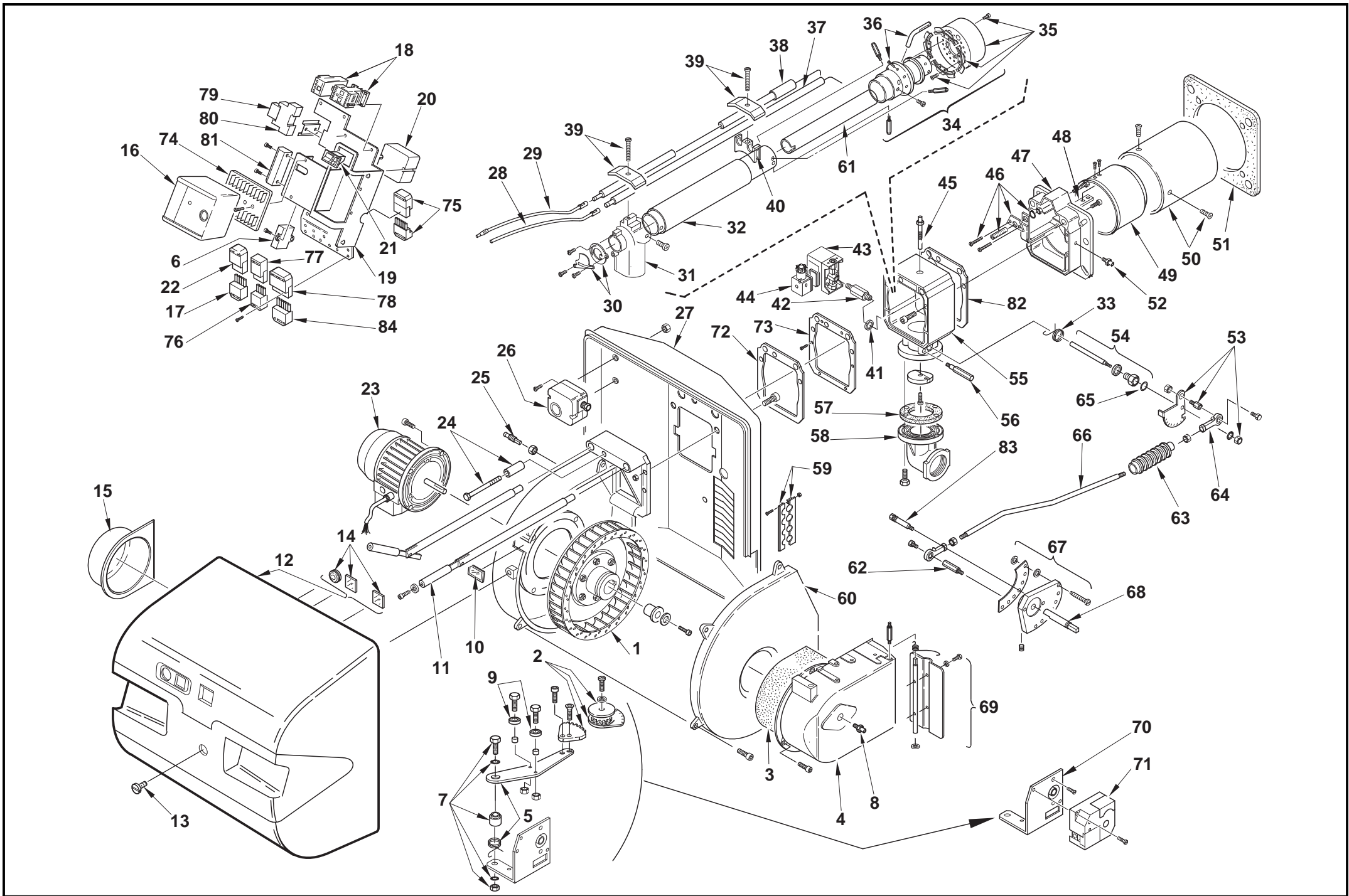

N.	COD.	20038459-20038484 20038482-20038486 *	DESCRIZIONE	DESCRIPTION	DESCRIPTION	BESCHREIBUNG	DENOMINACION	MATRICOLA BRUCIATORE BURNER SERIAL NUMBER MATICULE BRULEUR BRENNER KENN-NUMMER MATICULA QUEMADORES	**
1	3013768	• •	GIRANTE	FAN	TURBINE	GEBLÄSERAD	TURBINA		C
2	3012063	• •	QUADRANTE	GRADUATE SECTOR	SECTEUR GRADUE	SKALENSEGMENT	MIRILLA		
3	3003830	• •	FONOASSORBENTE	SOUND DAMPING	INSONORISANT	GERÄUSCHDÄMMUNG	AISLAMIENTO ACUSTICO		
4	3012077	• •	BOCCA D'ASPIRAZIONE	AIR INTAKE	BOITIER D'ASPIRATION	ANSAUGÖFFNUNG	BOCA ASPIRACION		
5	3013478	• •	MOLLA - LEVA	SPRING - LEVER	RESSORT - LEVIER	FEDER - HEBEL	MUELLE - LEVA		
6	3012155	• •	FILTRO ANTIRADIODISTURBO	DEGLITCHER	FILTRE	ENTSTÖRER	FILTRO ANTI-INTERFERENCIA		C
7	3003843	• •	PERNO	SCREW	VIS CREUSE	HOHLKERNSCHRAUBE	GUIA		
8	3012088	• •	RACCORDO	CONNECTOR	MAMELON	NIPPEL	RACORD		C
9	3003841	• •	CUSCINETTO	BEARING	ROULEMENT	LAGER	COJINETE		
10	3003763	• •	VISORE	INSPECTION WINDOW	WISEUR	SICHTFENSTER	VISOR		
11	3013769	• •	PERNO	BAR EXTENSION	RALLONGE DE GLISSIERE	VERLÄNGERUNG	EXTENSIÓN PERNO		C
12	3013770	• •	COFANO	COVER	COFFRET	VERKLEIDUNG	ENVOLVENTE		
13	3003766	• •	VITE	SCREW	VIS	SCHRAUBE	TORNILLO		
14	3013679	• •	MEMBRANA + VETRINO	MEMBRANE + VIEWING PORT	MEMBRANE + REGARD	MEMBRAN + VERSCHLUßS- TOPFEN	MEMBRANA + MIRILLA		
15	3013771	• •	PROTEZIONE MOTORE	GRID MOTOR	PROTECTION MOTEUR	SCHUTZGITTER MOTOR	PROTECCIÓN MOTOR		
16	3013362	• •	APPARECCHIATURA	CONTROL BOX	BOITE DE CONTROLE	STEUERGERÄT	CAJA CONTROL		B
17	3007589	• •	SPINA A 5 POLI	5 POLE PLUG	FICHE 5 POLES	STECKER 5 POLEN	CONECTOR MACHO DE 5 CONTAC.		
18	3003959	• •	AVVIATORE	STARTER	DEMARREUR	ANLASSER	ARRANCADOR		C
19	3013772	• •	SUPPORTO	SUPPORT	SUPPORT	HALTER	CORCHETE		
20	3002480	• •	TRASFORMATORE	TRANSFORMER	TRANSFORMATEUR	ZÜNDTRANSFORMATOR	TRANSFORMADOR		B
21	3012080	• •	INTERRUTTORE	SWITCH	INTERRUPTEUR	SCHALTER	INTERUCTOR		
22	3007434	• •	PRESA 5 POLI	5 POLE SOCKET	PRISE 5 POLES	5 - POLIGE STECKDOSE	CONECTOR HEMBRA DE 5 CONTAC.		
23	20019536	• •	MOTORE	MOTOR	MOTEUR	MOTOR	MOTOR		
24	3003778	• •	ALBERINO	SHORT SHAFT	AXE	KLEINWELLE	ARBORILLO		
25	3003891	• •	RACCORDO	CONNECTOR	MAMELON	NIPPEL	RACORD		C
26	3007444	• •	PRESSOSTATO ARIA	AIR PRESSURE SWITCH	PRESSOSTAT AIR	LUFTDRUCKWÄCHTER	PRESÓSTATO AIRE		A

N.	COD.	20038459-20038484 20038482-20038486 *	DESCRIZIONE	DESCRIPTION	DESCRIPTION	BESCHREIBUNG	DENOMINACION	MATRICOLA BRUCIATORE BURNER SERIAL NUMBER MATRICULE BRULEUR BRENNER KENN-NUMMER MATRICULA QUEMADORES	**
27	3013773	• •	SCUDO ANTERIORE	FRONT SHIELD	BOUCLIER AVANT	VORDERES SCHILD	ESCUDO ANTERIOR		
28	3003848	• •	COLLEGAMENTO SONDA	PROBE LEAD	CONNEXION POUR SONDE	VERBINDUNG FÜR SONDE	CABLE CONEXIÓN SONDA		A
29	3003794	• •	COLLEGAM. ELETTRODO	H.T. LEAD	CONNEXION POUR ELEC- TRODE	VERBINDUNG FÜR ELE- KTRODE	CABLE CONEXIÓN ELEC- TRODO		A
30	3012014	• •	GHIERA	RING NUT	BAGUE	NUTMUTTER	TUERCA		
31	3012412	• •	GOMITO	ELBOW	COUDE	SCHLITTEN	CODO		
32	3012040	•	TUBO ESTERNO	EXTERIOR TUBE	TUYAU EXTERIEUR	AUSSERER ROHR	TUBO EXTERNO		
32	3012041	•	TUBO ESTERNO	EXTERIOR TUBE	TUYAU EXTERIEUR	AUSSERER ROHR	TUBO EXTERNO		
33	3013204	• •	MOLLA	SPRING	RESSORT	FEDER	MUELLE		
34	20048998	• •	DISTRIBUTORE	GAS HEAD	DISTRIBUTEUR	GASVERTEILER	DISTRIBUIDOR		
35	20049000	• •	TAZZA	AIR DIFFUSER	DIFFUSEUR D'AIR	STAUSCHEIBE	DIFUSOR DEL AIRE		
36	3012715	• •	TUBETTO	TUBE	TUYAU	RÖHRCHEN	TUBITO		
37	3012176	•	SONDA	PROBE	SONDE	FÜHLER	SONDA		A
37	3012179	•	SONDA	PROBE	SONDE	FÜHLER	SONDA		A
38	3012017	•	ELETTRODO	ELECTRODE	ELECTRODE PORCELAINE	ELEKTRODE	ELECTRODO		A
38	3012018	•	ELETTRODO	ELECTRODE	ELECTRODE PORCELAINE	ELEKTRODE	ELECTRODO		A
39	3003409	• •	CAVALLOTTO	U BOLT	CAVALIER	BÜGELBOLZEN	SOPORTE FIJACIÓN		
40	3012419	• •	SUPPORTO	SUPPORT	SUPPORT	HALTER	SOPORTE		
41	3007166	• •	GUARNIZIONE	SEAL	RONDELLE	METALLDICHTUNG	JUNTA		
42	3003864	• •	RACCORDO	CONNECTOR	MAMELON	NIPPEL	RACORD		
43	3003660	• •	PRESSOSTATO GAS	GAS PRESSURE SWITCH	PRESSOSTAT GAZ	GASDRUCKWÄCHTER	PRESOSTATO DEL AIRE		
44	3006953	• •	PRESA	SOCKET	PRISE	STECKDOSE	CONECTOR		
45	3012049	• •	GRUPPO MISURAZIONE	TEST POINT	PRISE DE PRESSION	MESSNIPPEL	GRUPO TOMA DE PRESION		B
46	3012618	• •	GRUPPO REGOLAZIONE	ADJUSTMENT ASSEMBLY	GROUPE OBTURATION	DRUCKREGULIERUNG	GRUPO REGULACIÓN		
47	3012413	• •	FRONTONE	FONT PIECE	FACADE	VORDERTEIL	SOPORTE QUEMADOR		
48	3014095	•	SQUADRETTA	SQUARE	EQUERRE-SUPPORT	HALTER	ESCUADRA		
48	3014096	•	SQUADRETTA	SQUARE	EQUERRE-SUPPORT	HALTER	ESCUADRA		
49	3012416	• •	OTTURATORE	SHUTTER	OBTURATEUR	SCHIEBER	OBTURADOR		C

N.	COD.	20038459-20038484 20038482-20038486 *	DESCRIZIONE	DESCRIPTION	DESCRIPTION	BESCHREIBUNG	DENOMINACION	MATRICOLA BRUCIATORE BURNER SERIAL NUMBER MATRICULE BRULEUR BRENNER KENN-NUMMER MATRICULA QUEMADORES	**
50	3012415	•	IMBUTO FIAMMA	END CONE	EMBOUT GUEULARD	FLAMMENROHR	TUBO EXTREMO		B
50	3012930	•	IMBUTO FIAMMA	END CONE	EMBOUT GUEULARD	FLAMMENROHR	TUBO EXTREMO		B
51	3003991	• •	SCHERMO	FLANGE GASKET	ECRAN THERMIQUE	FLANSCHDICHTUNG	JUNTA AISLANTE		A
52	3003322	• •	RACCORDO	CONNECTOR	MAMELON	NIPPEL	RACORD		
53	3012355	• •	QUADRANTE	GRADUATE SECTOR	SECTEUR GRADUE	SKALENSEGMENT	MIRILLA		
54	3012059	• •	ALBERO MANICOTTO	BUTTERFLY VALVE SHAFT	AXE DE LA VANNE PAPILLON	SPINDEL GASDROSSEL	ARBORILLO MANGUITO		
55	3013779	• •	MANICOTTO	MANIFOLD	MANCHON	GASANSCHLUSS	MANGUITO		
56	3013780	• •	INDICE	INDEX	REPERE	INDEXSTIFT	INDICE		
57	3005482	• •	GUARNIZIONE	SEAL	RONDELLE	METALLDICHTUNG	JUNTA		B
58	3006803	• •	FLANGIA E GOMITO	FLANGE AND ELBOW	BRIDE ET COUDE	ANSCHLUSSFLANSCHGAS	BRIDA Y CODO		
59	3003780	• •	PASSACAVO	FAIRLEAD	PASSE-CABLE	KABELDURCHGANG	PASACABLES		
60	3013781	• •	GUSCIO	HALF-SHELL	COUVERCLE	HAUBE	CÁSCARA		
61	20049005	•	TUBO INTERNO	INTERIOR TUBE	TUYAU INTERIEUR	INNERER ROHR	TUBO INTERNO		
61	20049006	•	TUBO INTERNO	INTERIOR TUBE	TUYAU INTERIEUR	INNERER ROHR	TUBO INTERNO		
62	3003888	• •	DISTANZIALE	SPACER	ENTRETOISE	DISTANZSTÜCK	DISTANCIATOR		
63	3003883	• •	CUFFIA	COWLING	PROTECTION CAOUTCHOUC	SCHUTZ	CAPUZÓN		C
64	3006098	• •	SNODO SFERICO	PIN JOINT	CHAPE A ROTULE	KUGELGELENK	ARTICOLACION ESFERICA		
65	3003203	• •	ANELLO	PISTON SEAL	JOINT TORIQUE	LIPPENDICHTUNG	ANILLO		
66	3013782	• •	TIRANTE	TIE ROD	TIRANT	GESTÄNGE	TIRANTE		C
67	3012062	• •	CAMMA COMPLETA	CAM ASSEMBLY	CAME COMPLETE	VERBUNDREGLER	EXCÉNTRICO COMPLETO		C
68	3003885	• •	ALBERO CAMMA	CAM SHAFT	PIVOT DE LA CAME	NOCKENWELLE	ARBORILLO EXCÉNTRICO		
69	3012085	• •	GRUPPO SERRANDA	AIR DAMPER ASSEMBLY	GROUPE VOLET AIR	LUFTKLAPPE	CONJUNTO REGISTRO AIRE		
70	3013783	• •	SUPPORTO	SUPPORT	SUPPORT	HALTER	SOPORTE		
71	3012885	• •	SERVOMOTORE	SERVOMOTOR	SERVOMOTEUR	STELLMOTOR	SERVOMOTOR		B
72	3013784	• •	GUARNIZIONE	SEAL	RONDELLE	METALLDICHTUNG	JUNTA		C
73	3013785	• •	STAFFA	BRACKET	SUPPORT	HALTEBLECH	SOPORTE		
74	3003784	• •	MORSETTIERA	CONTROL BOX BASE	SOCLE	STECKSOCKEL	ZÓCALO CAJA CONTROL		C

N.	COD.	20038459-20038484 20038482-20038486 *	DESCRIZIONE	DESCRIPTION	DESCRIPTION	BESCHREIBUNG	DENOMINACION	MATRICOLA BRUCIATORE BURNER SERIAL NUMBER MATRICULE BRULEUR BRENNER KENN-NUMMER MATRICULA QUEMADORES	**
75	3013202	• •	PRESA + SPINA 6 POLI	6 POLE PLUG + SOCKET	FICHE + PRISE 6 POLES	STECK.+ STECKERBUCHSE 6 POLEN	CONEC. MACHO-HEMBRA DE 6 CONTAC.		
76	3006948	• •	SPINA A 4 POLI	4 POLE PLUG	FICHE 4 POLES	STECKER 4 POLEN	CONECTOR MACHO DE 4 CONTAC.		
77	3006949	• •	PRESA A 4 POLI	4 POLE SOCKET	PRISE 4 POLES	4 - POLIGE STECKDOSE	CONECTOR HEMBRA DE 4 CONTAC.		
78	3006938	• •	PRESA A 7 POLI	7 POLE SOCKE	PRISE 7 POLES	7 - POLIGE STECKDOSE	CONECTOR HEMBRA DE 7 CONTAC.		
79	3012842	• •	RELÈ	RELAY	RELAIS	RELAIS	RELÉ		
80	3012841	• •	ZOCCOLO RELE'	RELAY BASE	RELAIS BORNIER	RELAIS SOCKEL	RELÉ + ZOCALO		
81	3013813	• •	MORSETTIERA	CONTROL BOX BASE	SOCLE	STECKSOCKEL	ZÓCALO CAJA CONTROL		C
82	3012735	• •	GUARNIZIONE	SEAL	RONDELLE	METALLDICHTUNG	JUNTA		B
83	3003888	• •	DISTANZIALE	SPACER	ENTRETOISE	DISTANZSTÜCK	DISTANCIATOR		
84	3006937	• •	SPINA A 7 POLI	7 POLE PLUG	FICHE 7 POLES	STECKER 7 POLEN	CONECTOR MACHO DE 7 CONTAC.		

*

Versione Testa Lunga - Long Combustion Head Version - Version Tête Longue - Langer Brennkopf Ausführung - Versión alargado de tubo llama

**

RICAMBI CONSIGLIATI - ADVISED PARTS - RECHANGE CONSEIL - EMPFOHLENE ERSATZTEILE - RECAMBIOS ACONSEJADOS

A = Ricambi per dotazione minima - Spare parts for minimum fittings - Pièces détachées pour équipement minimum - Ersatzteile für minimale Ausstattung - Recambios para equipamiento mínimo

A+B = Ricambi per dotazione base di sicurezza - Spare parts for basic safety fittings - Pièces détachées pour équipement standard de sécurité - Ersatzteile für Sicherheitsgrundausrüstung - Recambios para equipamiento básico de seguridad

A+B+C = Ricambi per dotazione estesa di sicurezza - Spare parts for extended safety fittings - Pièces détachées pour équipement complet de sécurité - Ersatzteile für erweiterte Sicherheitsausstattung - Recambios para equipamiento general de seguridad

RIELLO

RIELLO S.p.A.
I-37045 Legnago (VR)
Tel.: +39.0442.630111
[http:// www.riello.it](http://www.riello.it)
[http:// www.rielloburners.com](http://www.rielloburners.com)