

**GB** **Forced draught gas burners**

Modulating operation



**RS BLU**

CODE	MODEL	TYPE
20072969	RS 1000/EV BLU	1133 T2
20072970	RS 1200/EV BLU	1134 T2



**Translation of the original instructions**

<b>1</b>	<b>Declarations</b> .....	<b>3</b>
<b>2</b>	<b>Information and general warnings</b> .....	<b>4</b>
2.1	Information about the instruction manual .....	4
2.1.1	Introduction.....	4
2.1.2	General dangers.....	4
2.1.3	Other symbols .....	4
2.1.4	Delivery of the system and the instruction manual.....	5
2.2	Guarantee and responsibility.....	5
<b>3</b>	<b>Safety and prevention</b> .....	<b>6</b>
3.1	Introduction.....	6
3.2	Personnel training .....	6
<b>4</b>	<b>Technical description of the burner</b> .....	<b>7</b>
4.1	Burner designation .....	7
4.2	Models available.....	7
4.3	Technical data .....	8
4.4	Electrical data.....	8
4.5	Burner categories - Countries of destination .....	9
4.6	Maximum dimensions.....	9
4.7	Firing rates .....	10
4.8	Test boiler.....	10
4.9	Burner description .....	11
4.10	Electrical panel description.....	12
4.11	Burner equipment.....	12
4.12	Control box for the air/fuel ratio (LMV52...) .....	13
4.13	Servomotor.....	15
<b>5</b>	<b>Installation</b> .....	<b>16</b>
5.1	Notes on safety for the installation .....	16
5.2	Handling .....	16
5.3	Preliminary checks .....	16
5.4	Operating position .....	17
5.5	Removal of the locking screws from the shutter.....	17
5.6	Preparing the boiler .....	17
5.6.1	Boring the boiler plate .....	17
5.6.2	Blast tube length.....	17
5.7	Securing the burner to the boiler .....	18
5.8	Access to head internal part.....	18
5.9	Electrodes and ionisation probe adjustment .....	19
5.10	Combustion head adjustment.....	19
5.11	Gas feeding .....	21
5.11.1	Gas feeding line .....	21
5.11.2	Gas train.....	22
5.11.3	Gas train installation.....	22
5.11.4	Gas pressure.....	22
5.12	Electrical wiring .....	24
5.12.1	Supply cables and external connections passage .....	24
5.12.2	Shielding the connections .....	25
5.12.3	Motor rotation .....	25
<b>6</b>	<b>Start-up, calibration and operation of the burner</b> .....	<b>26</b>
6.1	Notes on safety for the first start-up .....	26
6.2	Adjustments prior to ignition .....	26
6.2.1	Revolution sensor.....	26

6.3	Burner start-up .....	27
6.4	Burner ignition .....	27
6.5	Combustion air adjustment .....	27
6.5.1	Air / gas adjustment and output modulation .....	28
6.6	Pressure switch adjustment .....	29
6.6.1	Air pressure switch - check CO .....	29
6.6.2	Maximum gas pressure switch .....	29
6.6.3	Minimum gas pressure switch .....	29
6.6.4	PVP pressure switch kit .....	29
6.7	Final checks (with burner operating) .....	30
<b>7</b>	<b>Maintenance .....</b>	<b>31</b>
7.1	Notes on safety for the maintenance .....	31
7.2	Maintenance programme .....	31
7.2.1	Maintenance frequency .....	31
7.2.2	Checking and cleaning .....	31
7.2.3	Positioning the revolution sensor .....	32
7.3	Opening the burner .....	33
7.4	Closing the burner .....	33
<b>8</b>	<b>Faults - Probable causes - Solutions .....</b>	<b>34</b>
<b>A</b>	<b>Appendix - Accessories .....</b>	<b>35</b>
<b>B</b>	<b>Appendix - Electrical panel layout .....</b>	<b>37</b>

**1 Declarations**

**Declaration of conformity in accordance with ISO / IEC 17050-1**

Manufacturer: RIELLO S.p.A.  
 Address: Via Pilade Riello, 7  
 37045 Legnago (VR)  
 Product: Forced draught gas burners  
 Model: RS 1000/EV BLU  
 RS 1200/EV BLU

These products are in compliance with the following Technical Standards:  
 EN 676  
 EN 12100  
 and according to the European Directives:

GAD	2009/142/EC	Gas Devices Directive
MD	2006/42/EC	Machine Directive
LVD	2006/95/EC	Low Voltage Directive
EMC	2004/108/EC	Electromagnetic Compatibility

Such products are marked as follows:

 RS 1000/EV BLU CE-0085CN0119 Class 3 (EN 676)  
 RS 1200/EV BLU CE-0085CN0120 Class 3 (EN 676)

The quality is guaranteed by a quality and management system certified in accordance with UNI EN ISO 9001.

**Manufacturer's Declaration**

RIELLO S.p.A. declares that the following products comply with the NOx emission limits specified by German standard "1. BImSchV revision 26.01.2010".

Product	Type	Model	Output
Forced draught gas burners	1133 T2	RS 1000/EV BLU	1100 - 10100 kW
	1134 T2	RS 1200/EV BLU	1500 - 11100 kW

Legnago, 21.05.2015

Executive General Manager  
 RIELLO S.p.A. - Burner Department  
 Mr. U. Ferretti

Research & Development Director  
 RIELLO S.p.A. - Burner Department  
 Mr. F. Comencini

**2 Information and general warnings**

**2.1 Information about the instruction manual**

**2.1.1 Introduction**

The instruction manual supplied with the burner:

- is an integral and essential part of the product and must not be separated from it; it must therefore be kept carefully for any necessary consultation and must accompany the burner even if it is transferred to another owner or user, or to another system. If the manual is lost or damaged, another copy must be requested from the Technical Assistance Service of the area;
- is designed for use by qualified personnel;
- offers important indications and instructions relating to the installation safety, start-up, use and maintenance of the burner.

**Symbols used in the manual**

In some parts of the manual you will see triangular DANGER signs. Pay great attention to these, as they indicate a situation of potential danger.

**2.1.2 General dangers**

The **dangers** can be of **3 levels**, as indicated below.



Maximum danger level!  
This symbol indicates operations which, if not carried out correctly, cause serious injury, death or long-term health risks.



This symbol indicates operations which, if not carried out correctly, may cause serious injury, death or long-term health risks.



This symbol indicates operations which, if not carried out correctly, may cause damage to the machine and/or injury to people.

**2.1.3 Other symbols**



**DANGER: LIVE COMPONENTS**  
This symbol indicates operations which, if not carried out correctly, lead to electric shocks with lethal consequences.



**DANGER: FLAMMABLE MATERIAL**  
This symbol indicates the presence of flammable materials.



**DANGER: BURNING**  
This symbol indicates the risks of burns due to high temperatures.



**DANGER: CRUSHING OF LIMBS**  
This symbol indicates the presence of moving parts: danger of crushing of limbs.



**WARNING: MOVING PARTS**  
This symbol indicates that you must keep limbs away from moving mechanical parts; danger of crushing.



**DANGER: EXPLOSION**  
This symbol signals places where an explosive atmosphere may be present. An explosive atmosphere is defined as a mixture - under atmospheric conditions - of air and flammable substances in the form of gases, vapours, mist or dust in which, after ignition has occurred, combustion spreads to the entire unburned mixture.



**PERSONAL PROTECTION EQUIPMENT**  
These symbols indicate the equipment that must be worn and kept by the operator for protection against threats against safety and/or health while at work.



**OBLIGATION TO ASSEMBLE THE HOOD AND ALL THE SAFETY AND PROTECTION DEVICES**  
This symbol signals the obligation to reassemble the hood and all the safety and protection devices of the burner after any maintenance, cleaning or checking operations.



**ENVIRONMENTAL PROTECTION**  
This symbol gives indications for the use of the machine with respect for the environment.



**IMPORTANT INFORMATION**  
This symbol indicates important information that you must bear in mind.

- This symbol indicates a list.

**Abbreviations used**

Ch.	Chapter
Fig.	Figure
Page	Page
Sec.	Section
Tab.	Table

**2.1.4 Delivery of the system and the instruction manual**

When the system is delivered, it is important that:

- the instruction manual is delivered to the user by the system manufacturer, with the recommendation to keep it in the room where the heat generator is to be installed.
- The instruction manual shows:
  - the serial number of the burner;

.....

- the address and telephone number of the nearest Assistance Centre.

.....  
 .....  
 .....

- The system supplier must carefully inform the user about:
  - the use of the system;
  - any further tests that may be required before activating the system;
  - maintenance, and the need to have the system checked at least once a year by a representative of the manufacturer or another specialised technician.
 To ensure a periodic check, the manufacturer recommends the drawing up of a Maintenance Contract.

**2.2 Guarantee and responsibility**

The manufacturer guarantees its new products from the installation date, in accordance with the regulations in force and/or the sales contract. At the moment of the first start-up, check that the burner is integral and complete.



**WARNING**

Failure to observe the information given in this manual, operating negligence, incorrect installation and carrying out of non authorised modifications will result in the annulment by the manufacturer of the guarantee that it supplies with the burner.

In particular, the rights to the guarantee and the responsibility will no longer be valid, in the event of damage to things or injury to people, if such damage/injury was due to any of the following causes:

- incorrect installation, start-up, use and maintenance of the burner;
- improper, incorrect or unreasonable use of the burner;
- intervention of unqualified personnel;
- carrying out of unauthorised modifications on the equipment;
- use of the burner with safety devices that are faulty, incorrectly applied and/or not working;
- installation of untested supplementary components on the burner;
- powering of the burner with unsuitable fuels;
- faults in the fuel supply system;
- use of the burner even following an error and/or an irregularity;
- repairs and/or overhauls incorrectly carried out;
- modification of the combustion chamber with inserts that prevent the regular development of the structurally established flame;
- insufficient and inappropriate surveillance and care of those burner components most likely to be subject to wear and tear;
- the use of non-original components, including spare parts, kits, accessories and optional;
- force majeure.

**The manufacturer furthermore declines any and every responsibility for the failure to observe the contents of this manual.**

## 3 Safety and prevention

### 3.1 Introduction

The burners have been designed and built in compliance with current regulations and directives, applying the known technical rules of safety and envisaging all the potential danger situations.

It is necessary, however, to bear in mind that the imprudent and clumsy use of the equipment may lead to situations of death risk for the user or third parties, as well as the damaging of the burner or other items. Inattention, thoughtlessness and excessive confidence often cause accidents; the same applies to tiredness and sleepiness.

It is a good idea to remember the following:

- The burner must only be used as expressly described. Any other use should be considered improper and therefore dangerous.

In particular:

it can be applied to boilers operating with water, steam, diathermic oil, and to other users expressly named by the manufacturer;

the type and pressure of the fuel, the voltage and frequency of the electrical power supply, the minimum and maximum deliveries for which the burner has been regulated, the pressurisation of the combustion chamber, the dimensions of the combustion chamber and the room temperature must all be within the values indicated in the instruction manual.

- Modification of the burner to alter its performance and destinations is not allowed.
- The burner must be used in exemplary technical safety conditions. Any disturbances that could compromise safety must be quickly eliminated.
- Opening or tampering with the burner components is not allowed, apart from the parts requiring maintenance.
- Only those parts envisaged by the manufacturer can be replaced.



The manufacturer guarantees safety and proper functioning only if all burner components are intact and positioned correctly.

### 3.2 Personnel training

The user is the person, body or company that has acquired the machine and intends to use it for the specific purpose. He is responsible for the machine and for the training of the people working around it.

The user:

- undertakes to entrust the machine exclusively to suitably trained and qualified personnel;
- undertakes to inform his personnel in a suitable way about the application and observance of the safety instructions. With that aim, he undertakes to ensure that everyone knows the use and safety instructions for his own duties;
- Personnel must observe all the danger and caution indications shown on the machine.
- Personnel must not carry out, on their own initiative, operations or interventions that are not within their province.
- Personnel must inform their superiors of every problem or dangerous situation that may arise.
- The assembly of parts of other makes, or any modifications, can alter the characteristics of the machine and hence compromise operating safety. The manufacturer therefore declines any and every responsibility for any damage that may be caused by the use of non-original parts.

In addition:



- the user must take all the measures necessary to prevent unauthorised people gaining access to the machine
- the user must inform the manufacturer if faults or malfunctioning of the accident prevention systems are noticed, along with any presumed danger situation
- personnel must always use the personal protective equipment envisaged by legislation and follow the indications given in this manual



**4 Technical description of the burner**

**4.1 Burner designation**

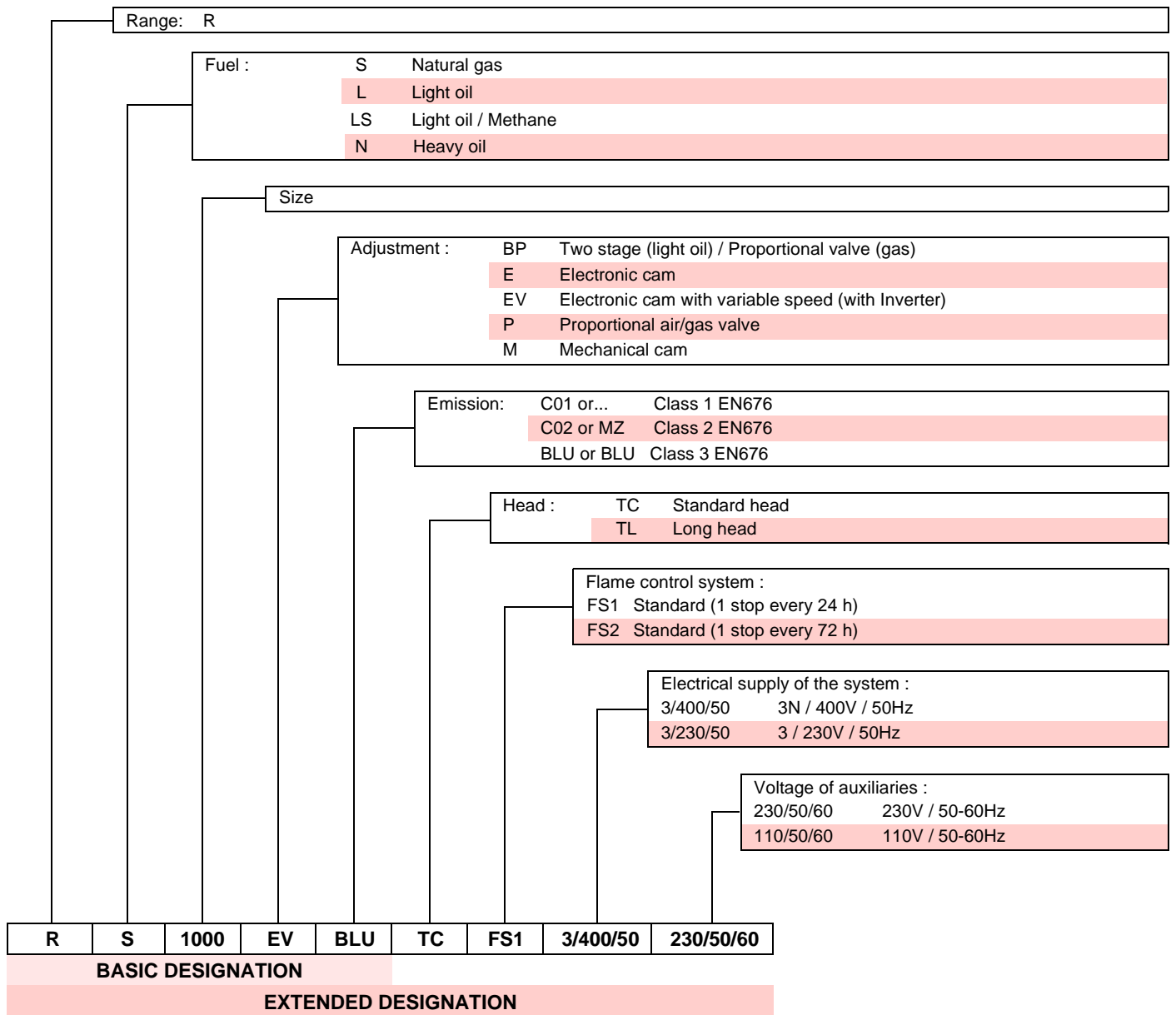

**4.2 Models available**

Designation		Voltage	Start-up	Code
RS 1000/EV BLU	TC	3/400/50	Direct/Inverter	20072969
RS 1200/EV BLU	TC	3/400/50	Direct/Inverter	20072970

Tab. A

**4.3 Technical data**

Model			RS 1000/EV BLU	RS 1200/EV BLU
Type			1133 T2	1134 T2
Power (1)	min - max	kW	1100/4000 - 10100	1500/5500 - 11100
Output (1)				
Fuels			Natural gas: G20 (methane gas) - G21 - G22 - G23 - G25	
Gas pressure at max. output (2) - Gas: G20/G25		mbar	64.5/92.7	80.5/114
Operation (3)			- Intermittent (min. 1 stop in 24 hours) - Modulating	
Standard applications			Boilers: water, steam, diathermic oil	
Ambient temperature		°C	0 - 50	
Combustion air temperature		°C max	60	
Noise levels (4)	Sound pressure	dB(A)	85	89.3
	Sound power		99	99.7
Weight		Kg	460	500

**Tab. B**

- (1) Reference conditions: Ambient temperature 20°C - Gas temperature 15°C - Barometric pressure 1013 mbar - Altitude 0 m a.s.l.
- (2) Pressure on the socket 5) (Fig. 4) with zero pressure in the combustion chamber and at maximum burner output.
- (3) The burner is factory set for FS1 operation (1 stop every 24 hours); it can be converted to FS2 operation (continuous - 1 stop every 72 hours), by changing the parameters using the AZL Display menu.
- (4) Sound pressure measured in manufacturer's combustion laboratory, with burner operating on test boiler and at maximum rated output. The sound power is measured with the "Free Field" method, as per EN 15036, and according to an "Accuracy: Category 3" measuring accuracy, as set out in EN ISO 3746.

**4.4 Electrical data**

Model			RS 1000/EV BLU	RS 1200/EV BLU
Electrical supply			3N ~ 400V +/-10% 50Hz	
Fan motor IE2	rpm		2964	2920
	Hz		50	50
	V		400/690	400/690
	kW		22	25
	A		38.6/22.3	44.1 - 25.5
Ignition transformer	V1 - V2 I1 - I2		230 V - 2 x 5 kV 1,9 A - 35 mA	
Absorbed electrical power	kW max		24	27
Protection level			IP 54	

**Tab. C**

Model			RS 1000/EV BLU	RS 1200/EV BLU
Electrical supply			3N ~ 400V +/-10% 50 Hz	
Fan motor IE3	rpm		2880	2880
	Hz		50	50
	V		400/690	400/690
	kW		22	25
	A		38.2/22.3	43.4/25.1
Ignition transformer	V1 - V2 I1 - I2		230 V - 2 x 5 kV 1,9 A - 35 mA	
Absorbed electrical power	kW max		24	27
Protection level			IP 54	

**Tab. D**

**4.5 Burner categories - Countries of destination**

Country of destination	Gas category
SE - FI - AT - GR - DK - ES - GB - IT - IE - PT - IS - CH - NO	I <sub>2H</sub>
DE	I <sub>2ELL</sub>
NL	I <sub>2L</sub>
FR	I <sub>2Er</sub>
BE	I <sub>2E(R)B</sub>
LU - PL	I <sub>2E</sub>

Tab. E

**4.6 Maximum dimensions**

The maximum dimensions of the burner are shown in Fig. 1. Bear in mind that inspection of the combustion head requires the burner to be opened and the rear part turned on the hinge.

The maximum dimensions of the open burner are indicated by the L and R positions.

The I position is reference for the refractory thickness of the boiler door.

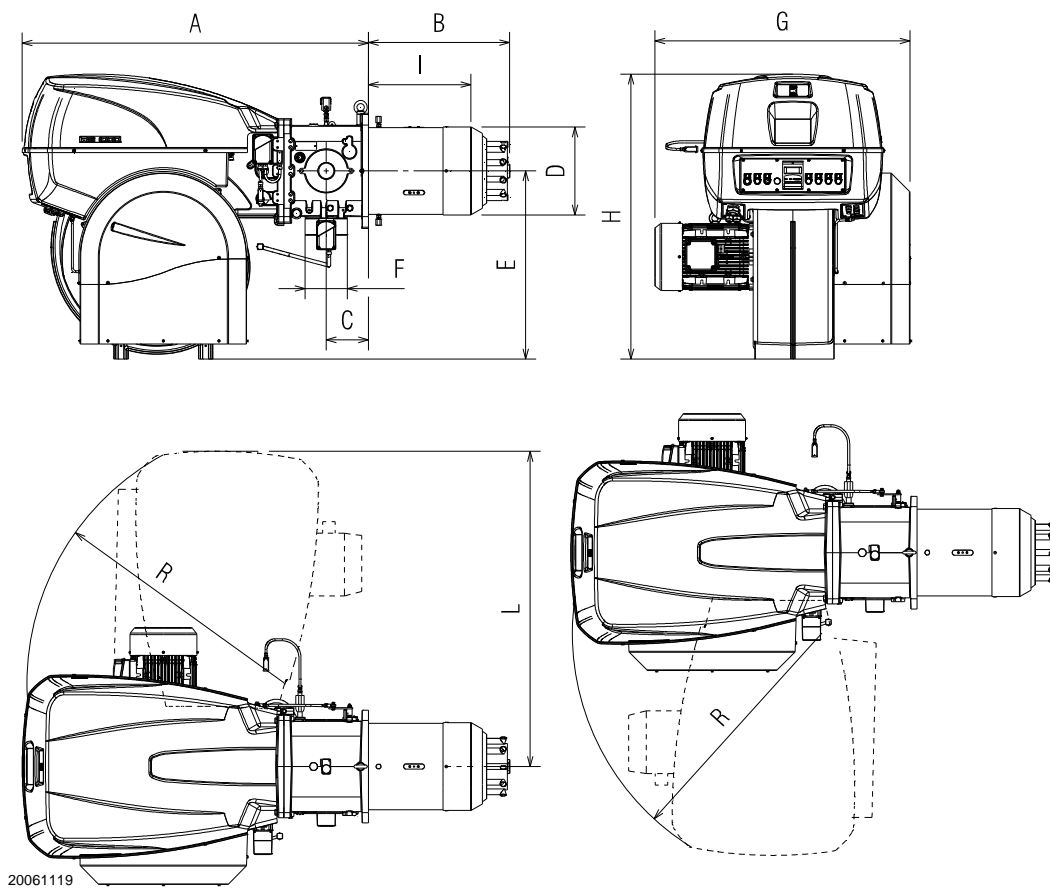

Fig. 1

mm	A	B	C	D	E	F	G	H	I	L	R
RS 1000/EV BLU	1637	669	200	413	885	DN80	1206	1338	485	1493	1350
RS 1200/EV BLU	1637	670	200	456	885	DN80	1250	1338	485	1493	1350

Tab. F

**4.7 Firing rates**

The **MAXIMUM OUTPUT** is chosen from within the continuous diagram area (Fig. 2).

The **MINIMUM OUTPUT** must not be lower than the minimum limit of the diagram:

- RS 1000/EV BLU = 4000 kW
- RS 1200/EV BLU = 5500 kW



The firing rate value (Fig. 2) has been obtained considering an ambient temperature of 20°C, an atmospheric pressure of 1013 mbar (approx. 0 m a.s.l.), and with the combustion head adjusted as shown on page 19.

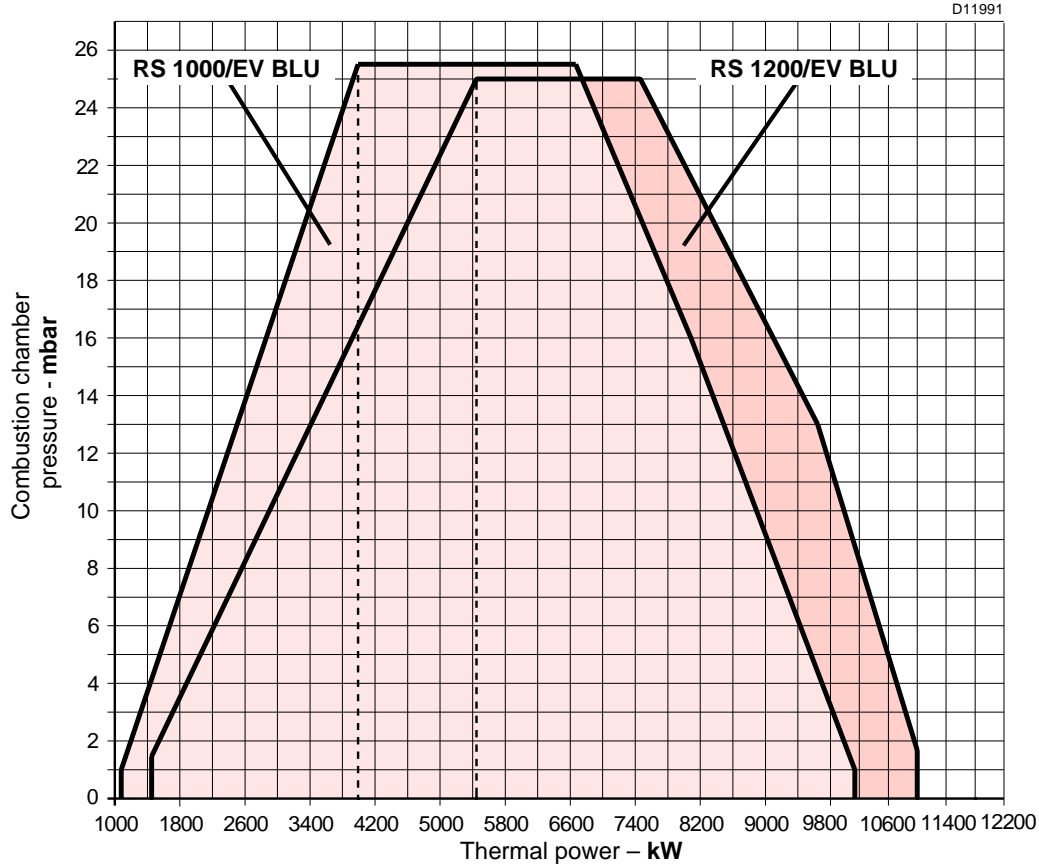

Fig. 2

**4.8 Test boiler**

The burner/boiler combination does not pose any problems if the boiler is EC approved and its combustion chamber dimensions are similar to those indicated in the diagram (Fig. 3).

If the burner must be combined with a boiler that has not been EC approved and/or its combustion chamber dimensions are clearly smaller than those indicated in the diagram, consult the manufacturer.

The firing rates were obtained in special test boilers, according to EN 676 regulations.

In Fig. 3 you can see the diameter and length of the test combustion chamber.

**Example:**  
Output 7000 kW - diameter 120cm - length 6m.

**MODULATING RATIO**

The modulating ratio, obtained in test boilers in accordance with standard EN 676, is 1:7.

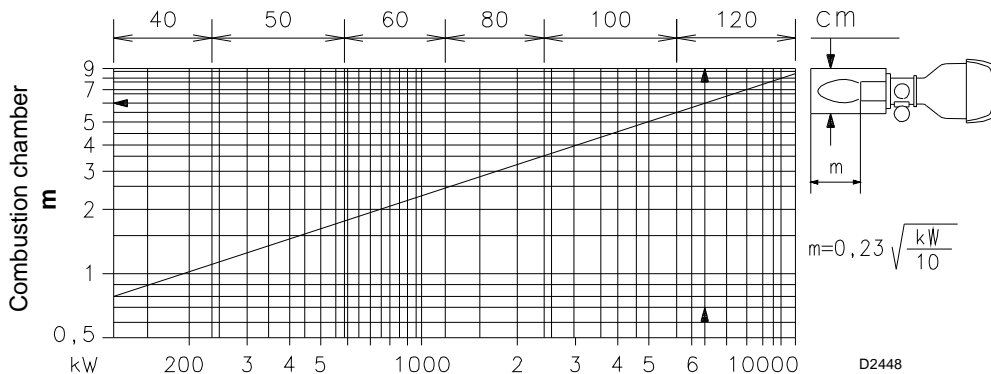

Fig. 3

4.9 Burner description

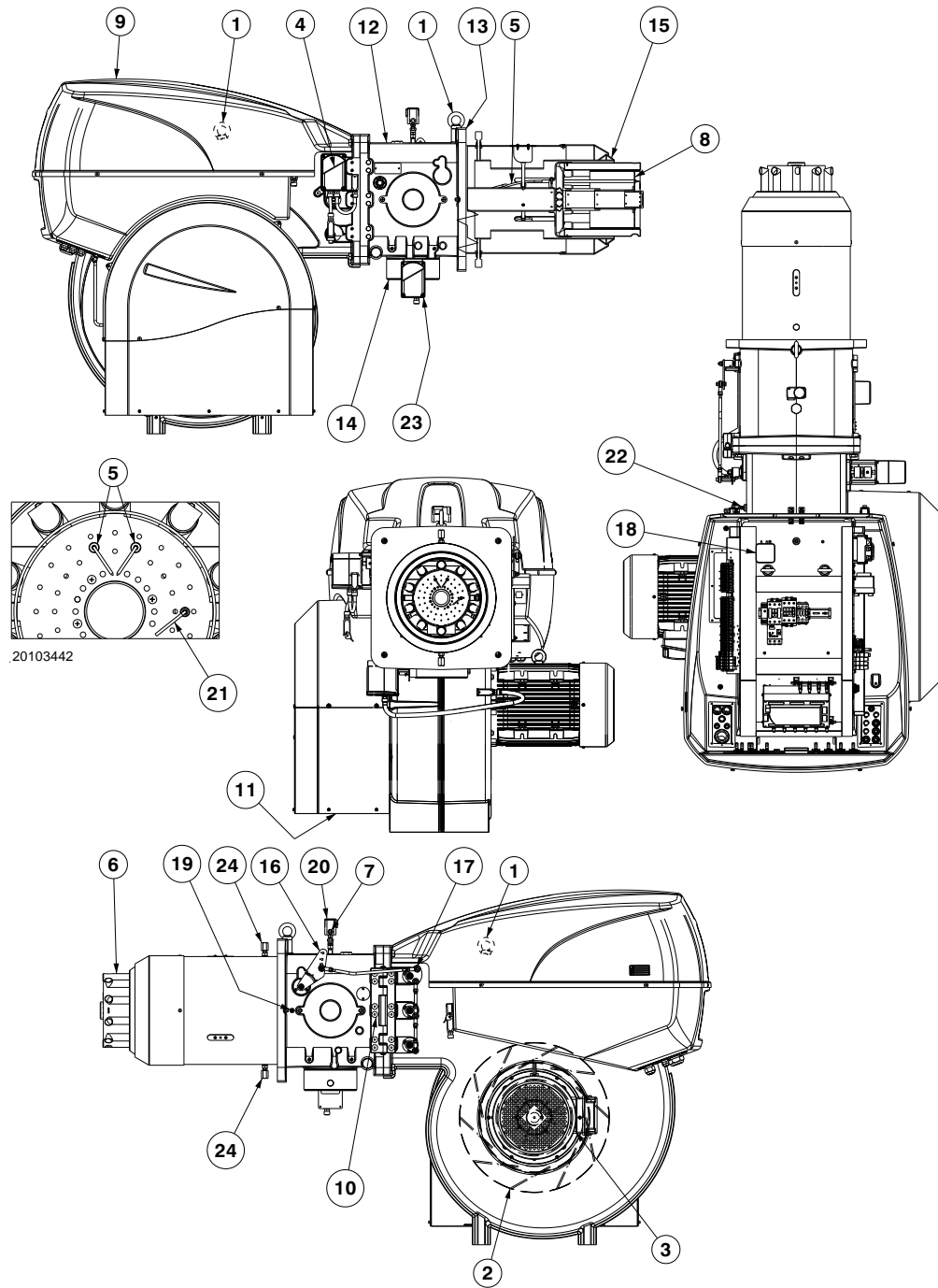

Fig. 4

- |  |   |
|--|---|
| <ul style="list-style-type: none"> <li>1 Lifting rings</li> <li>2 Fan</li> <li>3 Fan motor with speed sensor</li> <li>4 Air damper servomotor</li> <li>5 Electrodes</li> <li>6 Combustion head</li> <li>7 Combustion head gas pressure test point</li> <li>8 Flame stability disc</li> <li>9 Electrical panel casing</li> <li>10 Hinge for opening the burner</li> <li>11 Fan air inlet</li> <li>12 Pipe coupling</li> <li>13 Gasket for boiler fixing</li> <li>14 Gas regulator</li> <li>15 Shutter</li> <li>16 Combustion head movement lever</li> <li>17 Air damper movement lever</li> </ul> | <ul style="list-style-type: none"> <li>18 Air pressure switch (differential operating type)</li> <li>19 Combustion head air pressure test point</li> <li>20 Maximum gas pressure switch with pressure test point</li> <li>21 Ionisation probe</li> <li>22 Pressure test point for air pressure switch “+”</li> <li>23 Gas butterfly valve servomotor</li> <li>24 Locking screws of the shutter during the transport (replace them with the screws M12x16 supplied with the burner)</li> </ul> |
|--|---|



The burner can be opened to the right or to the left without links to the fuel supply side.  
When the burner is closed, the hinge can be refitted on the opposite side.

**4.10 Electrical panel description**

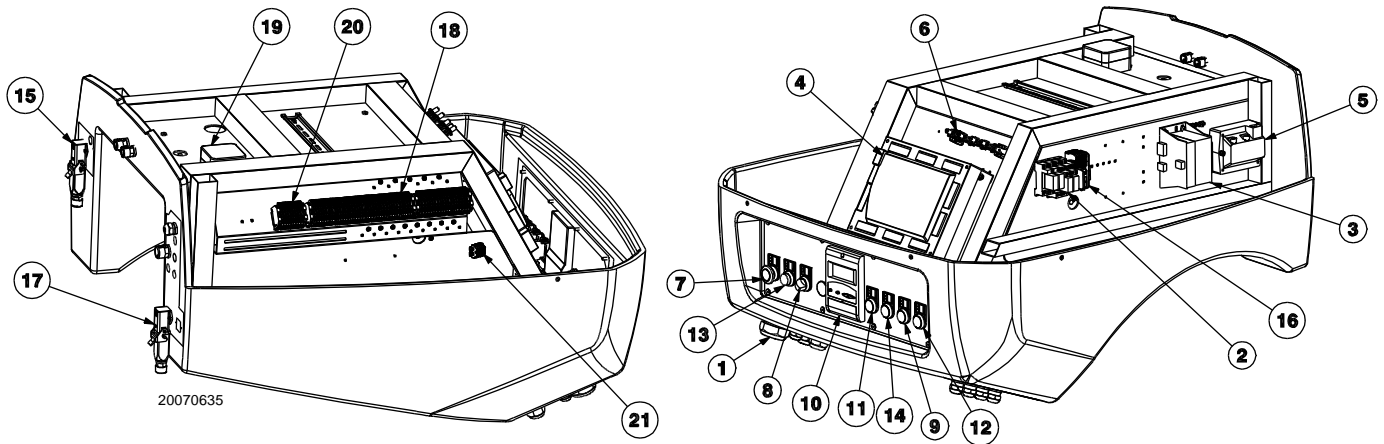

**Fig. 5**

- 1 Supply cables, external connections and kits
- 2 Clean contacts output relay
- 3 Electronic cam transformer
- 4 Electronic control box
- 5 Ignition transformer
- 6 Shielding terminals
- 7 Stop push-button
- 8 Off-automatic selector
- 9 Light signalling of main fuel valve open
- 10 AZL display
- 11 Light signalling of mains live state
- 12 Fan motor lockout warning lamp
- 13 Light signalling of burner lockout and reset switch
- 14 Heat request signal
- 15 Plug/socket servomotor
- 16 Auxiliary circuits fuse

- 17 Flame sensor plug/sensor socket
- 18 Main terminal supply board
- 19 Air pressure switch
- 20 Terminal board for O<sub>2</sub> kit
- 21 Revolution sensor terminal board

**NOTE**

Two types of burner lockout may occur:

- **Control box lockout:** switching on of button 13)(Fig. 5) (**red led**) signals that the burner is in lockout. Release by pressing button 13) or else use the Display 10).
- **Motor lockout:** to release the motor see the inverter manual.

**4.11 Burner equipment**

Gasket for gas train flange . . . . .	No. 1
Thermal insulation screen . . . . .	No. 1
Screws M12x16 . . . . .	No. 2
Gas flange fixing screws M16x70 . . . . .	No. 8
Screws M20x70 to secure the burner flange to the boiler . . . . .	No. 4
Pressure switch (for leak detection control) . . . . .	No. 1
Cable grommets kit for optional electrical wiring input . . . . .	No. 1
Technical instructions . . . . .	No. 1
Spare parts list . . . . .	No. 1

## 4.12 Control box for the air/fuel ratio (LMV52...)

### Warnings



To avoid accidents, material or environmental damage, observe the following instructions!

The LMV52 control box... is a safety device! Avoid opening or modifying it, or forcing its operation. Riello S.p.A. cannot assume any responsibility for damage resulting from unauthorised interventions!

#### Risk of explosion!

An incorrect configuration can provoke fuel overcharging, with the consequential risk of explosion! Operators must be aware that incorrect settings made on the AZL5... display and operating unit and incorrect settings of the fuel and / or air actuator positions can lead to dangerous burner operating conditions.

- All interventions (assembly and installation operations, assistance, etc.) must be carried out by qualified personnel.
- Before modifying the wiring in the LMV52 control box connection area, fully disconnect the system from the power supply (omnipolar separation). Check the system is not powered and cannot be accidentally reconnected. Failure to do this will lead to the risk of electrocution.
- Protection against electrocution from the LMV5... control box and all connected electric components is obtained with correct assembly.
- Before any intervention (assembly and installation operations, assistance, etc.), ensure the wiring is in order and that the parameters are correctly set, then make the safety checks.
- Falls and collisions can negatively affect the safety functions.

In this case, the control box must not be operated, even if it displays no evident damage.

- In programming mode, the position check of actuators and VSD (checking electronic fuel / air ratio control) is different from the check during automatic operation.

As for automatic operation, the actuators are guided together to the positions requested and, if an actuator does not reach the position requested, adjustments are made until the position is actually reached. However, in contrast to automatic operation, there are no time limits to these corrective actions.

The other actuators maintain their positions until all actuators have reached the positions currently required.

This is absolutely important to set the fuel / air ratio control system.

During the time the fuel / air ratio curves are being programmed, the person making the plant settings must continuously monitor the quality of the combustion process (e.g. by means of a flue gas analyser).

Also, if combustion levels are poor, or in the event of dangerous situations, the commissioning engineer must take appropriate action (e.g. switching off manually).

To ensure the safety and reliability of the LMV5... system, the following instructions must also be followed:

- avoid conditions that can favour the development of condensate and humidity. Otherwise, before switching on again, make sure that the entire control box is perfectly dry!
- Static charges must be avoided since they can damage the control box's electronic components when touched.



D9301

**Fig. 6**

### Mechanical structure

The LMV5... control box is a system to check the burners, based on a microprocessor and equipped with components to adjust and monitor medium and large capacity forced draught burners. The base control box of the LMV5... system incorporates the following components:

- Burner adjustment device with system for checking the seal of the gas valves
- Electronic fuel/air ratio monitoring device with a maximum of 6 (LMV52...) actuators
- Optional PID temperature / pressure controller (load controller)
- Optional VSD module Mechanical design

### Installation notes

- Check the electric wiring inside the boiler complies with the national and local safety regulations.
- Do not confuse the powered conductors with the neutral ones.
- Make certain that strain relief of the connected cables is in compliance with the relevant standards (e.g. as per DIN EN 60730 and DIN EN 60 335).
- Ensure that spliced wires cannot get into contact with neighbouring terminals. Use adequate ferrules.
- Arrange the HV ignition cables separately, as far as possible from the control box and the other cables.
- The burner manufacturer must protect unused AC 230V terminals with dummy plugs (refer to sections Suppliers of other accessory items).
- When wiring the unit, make sure that AC 230V mains voltage cables are run strictly separate from extra low-voltage cables to avoid risks of electrical shock hazard.

### Electrical connection of flame detector

It is important for signal transmission to be almost totally free of any disturbances or loss:

- always separate the detector cables from the other cables:
  - Line capacitance reduces the magnitude of the flame signal.
  - Use a separate cable.
- Respect the allowed cable lengths.

### Technical data

LMV52... base control box	Mains voltage	AC 230V -15% / +10%
	Mains frequency	50 / 60 Hz $\pm 6\%$
	Power absorption	< 30W (normal)
	Safety class	I, with components in compliance with II and III, according to DIN EN 60730-1
Load on 'input' terminals	F1 unit fuse (internal)	6.3 AT
	Main fuse of perm. network (external)	Max. 16 AT
	Undervoltage	
	• Safety switch-off from operating position to mains voltage	< AC 186 V
	• Restart when mains voltage picks up	> AC 188 V
	Oil pump / magnetic clutch (nominal voltage)	
	• Nominal current	2A
• Power factor	$\cos\phi > 0.4$	
Load on 'output' terminals	Air pressure switch test valve (nominal voltage)	
	• Nominal current	0.5A
	• Power factor	$\cos\phi > 0.4$
	<b>Total load on the contacts:</b>	
• Mains voltage	AC 230 V -15 % / +10 %	
• Total unit input current (safety circuit) load on contacts due to:	Max. 5 A	
- Fan motor contactor		
- Ignition transformer		
- Valve		
- Oil pump / magnetic clutch		
Cable lengths	<b>Single contact loading:</b>	
	Fan motor contactor (nominal voltage)	
	• Nominal current	1A
	• Power factor	$\cos\phi > 0.4$
	Alarm output (nominal voltage)	
	• Nominal current	1A
	• Power factor	$\cos\phi > 0.4$
	Ignition transformer (nominal voltage)	
	• Nominal current	2A
	• Power factor	$\cos\phi > 0.2$
	Fuel gas valve (nominal voltage)	
	• Nominal current	2A
	• Power factor	$\cos\phi > 0.4$
	Fuel oil valve (nominal voltage)	
• Nominal current	1A	
• Power factor	$\cos\phi > 0.4$	
Environmental conditions	Main line	Max. 100 m (100 pF/m)
	Operation	DIN EN 60721-3-3
	Climatic conditions	Classe 3K3
	Mechanical conditions	Classe 3M3
	Temperature range	-20...+60°C
Humidity	< 95% RH	

Tab. G



4.13 Servomotor

Warnings



WARNING

To avoid accidents, material or environmental damage, observe the following instructions!

Avoid opening, modifying or forcing the actuators.

- All interventions (assembly and installation operations, assistance, etc.) must be carried out by qualified personnel.
- Before modifying the wiring in the SQM4... system connection area, fully disconnect the burner control device from the power supply (omnipolar separation).
- To avoid the risk of electrocution, protect the connection terminals in a suitable manner and correctly fix the cover.
- Check the wiring is in order.
- Falls and collisions can negatively affect the safety functions. In this case, the unit must not be operated, even if it displays no evident damage.

Assembly notes

- Check the relevant national safety standards are respected.
- The connection between the actuator command shaft and the control element must be rigid, without any mechanical play.
- To avoid an excessive load on the bearings due to rigid hubs, the use of compensation clutches without any mechanical play is recommended (e.g. metal bellows-type clutches).

Installation notes

- Arrange the H.V. ignition cables separately, as far as possible from the control box and the other cables.
- To avoid the risk of electrocution, make sure that the 230V AC section of the SQM4... unit is fully separated from the functional low-voltage section.
- The static torque is reduced when the electrical supply of the actuator is switched off.
- The housing cover may only be removed for short periods of time for wiring or when making the addressing. In similar cases, make sure that dust or dirt does not penetrate inside the actuator.
- The actuator comprises a PCB with ESD-sensitive components.
- The top side of the board carries a cover which affords protection against direct contact. This protective cover must not be removed! The underside side of the board must not be touched.



WARNING

During the maintenance or replacement of the actuators, be careful not to invert the connectors.

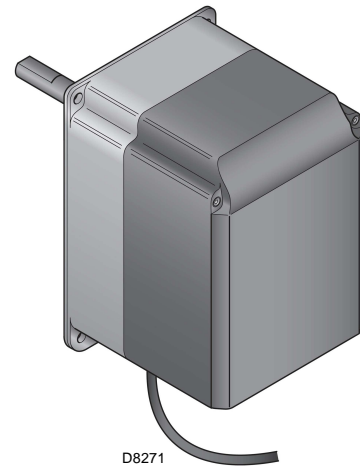

Fig. 7

Technical data

Operating voltage	AC 2 x 12V via bus cable from the base unit or via a separate transformer
Safety class	extra low-voltage with safe isolation from mains voltage
Power absorption	
– SQM45...	9...15 VA
– SQM48...	26...34 VA
Degree of protection	to EN 60 529, IP 54, provided adequate cable entries are used
Cable connection	RAST3,5 connectors
Rotation direction	- Anticlockwise (standard) - Clockwise (inverted rotation)
Nominal torque (max)	
– SQM45...	3 Nm
– SQM48...	20 Nm
Holding torque (max)	
– SQM45...	1.5 Nm
– SQM48...	20 Nm
Running time (min.) for 90°	
– SQM45...	10 s.
– SQM48...	30 s.
Weight	
– SQM45...	1 kg approx.
– SQM48...	1.6 kg approx.
Environmental conditions:	
Operation	DIN EN 60 721-3-3
Climatic conditions	Class 3K3
Mechanical conditions	Class 3M3
Temperature range	-20...+60°C
Humidity	< 95% RH

Tab. H

**5 Installation**

**5.1 Notes on safety for the installation**

After carefully cleaning all around the area where the burner will be installed, and arranging the correct lighting of the environment, proceed with the installation operations.



All the installation, maintenance and disassembly operations must be carried out with the electricity supply disconnected.



The installation of the burner must be carried out by qualified personnel, as indicated in this manual and in compliance with the standards and regulations of the laws in force.



Combustion air inside the boiler must be free from hazardous mixes (e.g.: chloride, fluoride, halogen); if present, it is highly recommended to carry out cleaning and maintenance more frequently.

**5.2 Handling**

The packaging of the burner includes a wooden platform, so it is possible to move the burner (still packaged) with a transpallet truck or fork lift truck.



The handling operations for the burner can be highly dangerous if not carried out with the greatest attention: keep any unauthorised people at a distance; check the integrity and suitability of the available means of handling.

Check also that the area in which you are working is empty and that there is an adequate escape area (i.e. a free, safe area to which you can quickly move if the burner should fall).

When handling, keep the load at not more than 20-25 cm from the ground.



After positioning the burner near the installation point, correctly dispose of all residual packaging, separating the various types of material.



Before proceeding with the installation operations, carefully clean all around the area where the burner will be installed.

**5.3 Preliminary checks**

**Checking the consignment**



After removing all the packaging, check the integrity of the contents. In the event of doubt, do not use the burner; contact the supplier.



The packaging elements (wooden cage or cardboard box, nails, clips, plastic bags, etc.) must not be abandoned as they are potential sources of danger and pollution; they should be collected and disposed of in the appropriate places.

RBL	A	B	C
D	E	F	
GAS-KAASU <input checked="" type="checkbox"/>	G	H	
GAZ-AEFO	G	H	
I			RIELLO SpA I-37045 Legnago (VR)
			CE

D10411

**Fig. 8**

**Checking the characteristics of the burner**

Check the identification label of the burner (Fig. 8), showing:

- A the burner model
- B the burner type
- C the cryptographic year of manufacture
- D the serial number
- E the data for electrical supply and the protection level
- F the electrical power consumption
- G the types of gas used and the relative supply pressures
- H the data of the burner's minimum and maximum output possibilities (see Firing rate)
- Warning.** The burner output must be within the boiler's firing rate
- I the category of the appliance/countries of destination



A burner label, or any other component, that has been tampered with, removed or is missing, prevents the definite identification of the burner and makes any installation or maintenance work difficult.

**5.4 Operating position**



- The burner is designed to operate only in positions 1, 2, 3 and 4 (Fig. 9).
- Installation 1 is preferable, as it is the only one that allows the maintenance operations as described in this manual.
- Installations 2, 3 and 4 permit operation but make maintenance and inspection of the combustion head more difficult.



- Any other position could compromise the correct operation of the appliance.
- Installation 5 is prohibited for safety reasons.

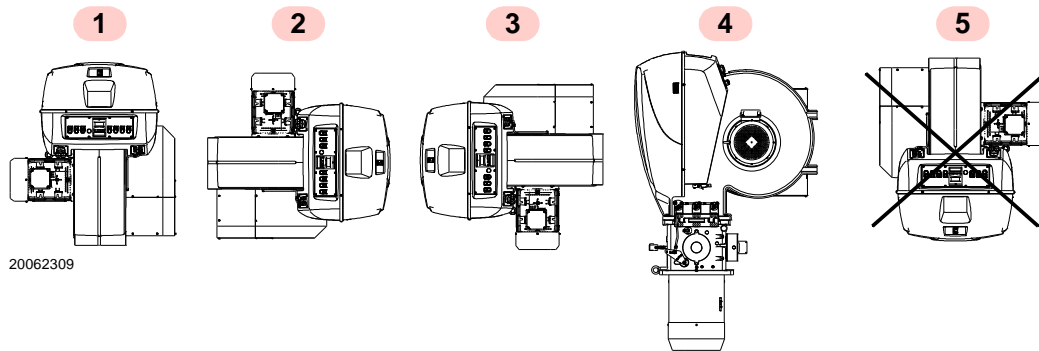

Fig. 9

**5.5 Removal of the locking screws from the shutter**



Remove the screws and the nuts 1)- 2)(Fig. 10), before installing the burner on the boiler.  
Replace them with the screws 3) M12x16 supplied with the burner.

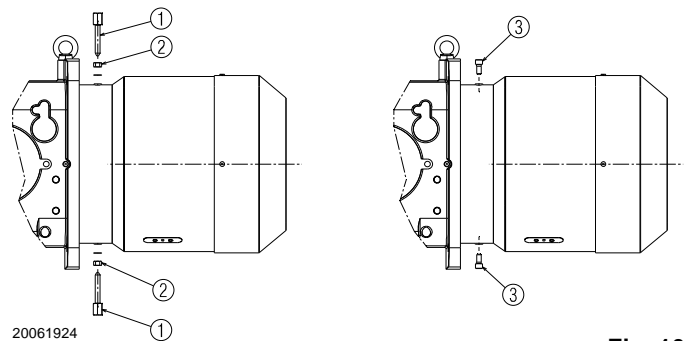

Fig. 10

**5.6 Preparing the boiler**

**5.6.1 Boring the boiler plate**

Pierce the closing plate of the combustion chamber, as in Fig. 11.  
The position of the threaded holes can be marked using the thermal insulation screen supplied with the burner.

**5.6.2 Blast tube length**

The length of the blast tube must be selected according to the indications provided by the manufacturer of the boiler, and in any case it must be greater than the thickness of the boiler door complete with its refractory.

For boilers with front flue passes 1) (Fig. 12) or flame inversion chamber, a protection in refractory material 5) must be inserted between the boiler fettling 2) and the blast tube 4).

This protection must not compromise the extraction of the blast tube.

For boilers with a water-cooled frontpiece, a refractory lining 2)-5)(Fig. 12) is not necessary, unless expressly requested by the boiler manufacturer.

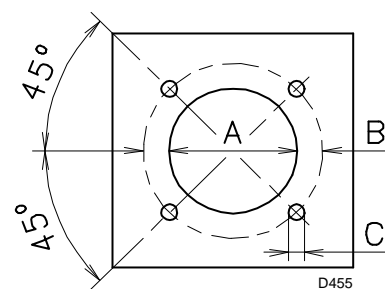

Fig. 11

mm	A	B	C
RS 1000/EV BLU	460	608	M 20
RS 1200/EV BLU	500	608	M 20

Tab. I

**5.7 Securing the burner to the boiler**



Prepare a suitable lifting system using rings 3)(Fig. 12).



The seal between burner and boiler must be airtight.

- Insert the thermal protection supplied with the blast tube 4).
- Insert the entire burner on the boiler hole, previously fitted, as in Fig. 11, and fix it with the screws supplied.

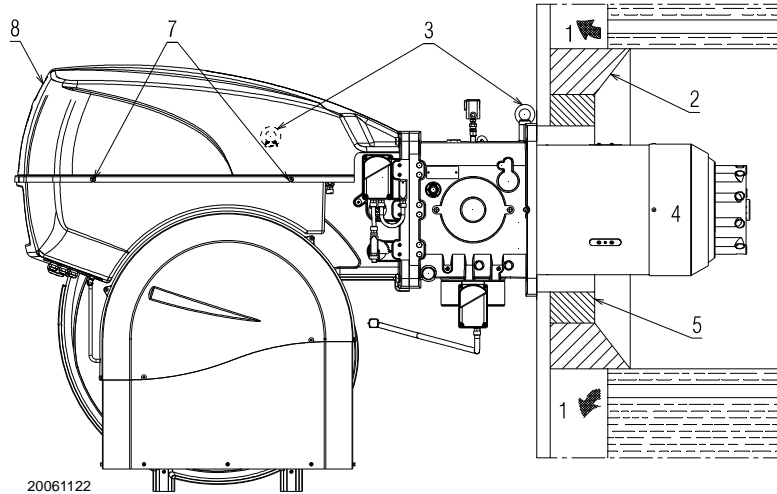

20061122

**Fig. 12**

**5.8 Access to head internal part**

In order to reach inside the combustion head (Fig. 13) proceed as follows:

- disconnect the gas servomotor socket 1);
- disconnect the head movement leverage 2);
- disconnect the connection to the gas pressure switch;
- remove the 4 fixing screws 3);
- partially open the burner (about 150 mm) on the hinge;
- disconnect the electrode cables 4) and ionisation probe;

- fully open the burner;
- remove the screw/gas pressure socket 5) of the head;
- pull out the inner part of the head 6).



Be careful as some drops of fuel may leak out during this phase.

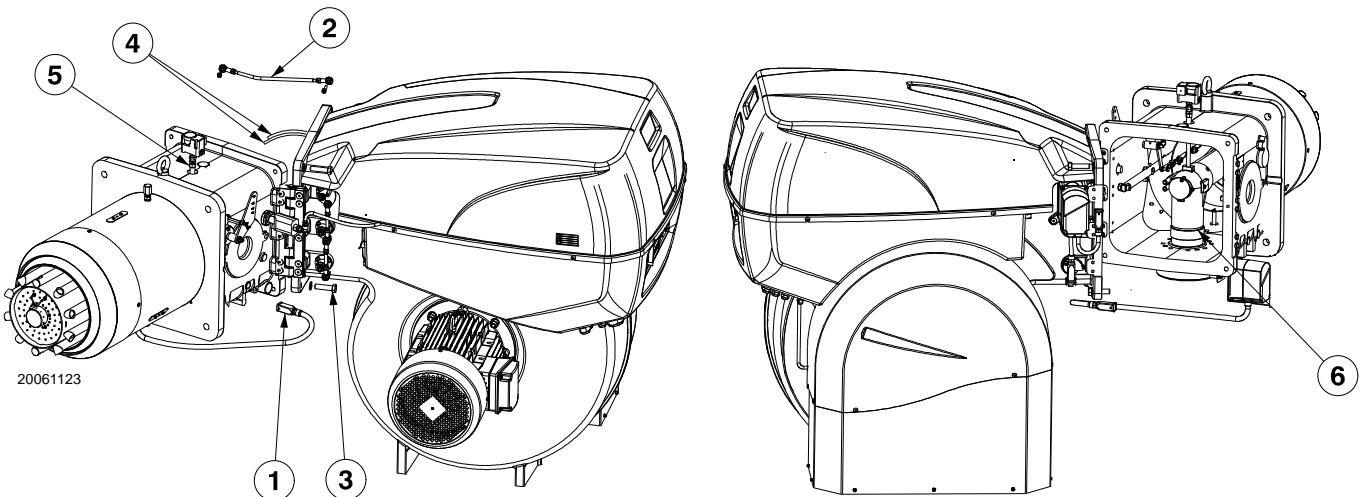

20061123

**Fig. 13**

**5.9 Electrodes and ionisation probe adjustment**



Position the electrodes and the ionisation probe according to the dimensions shown in Fig. 14.

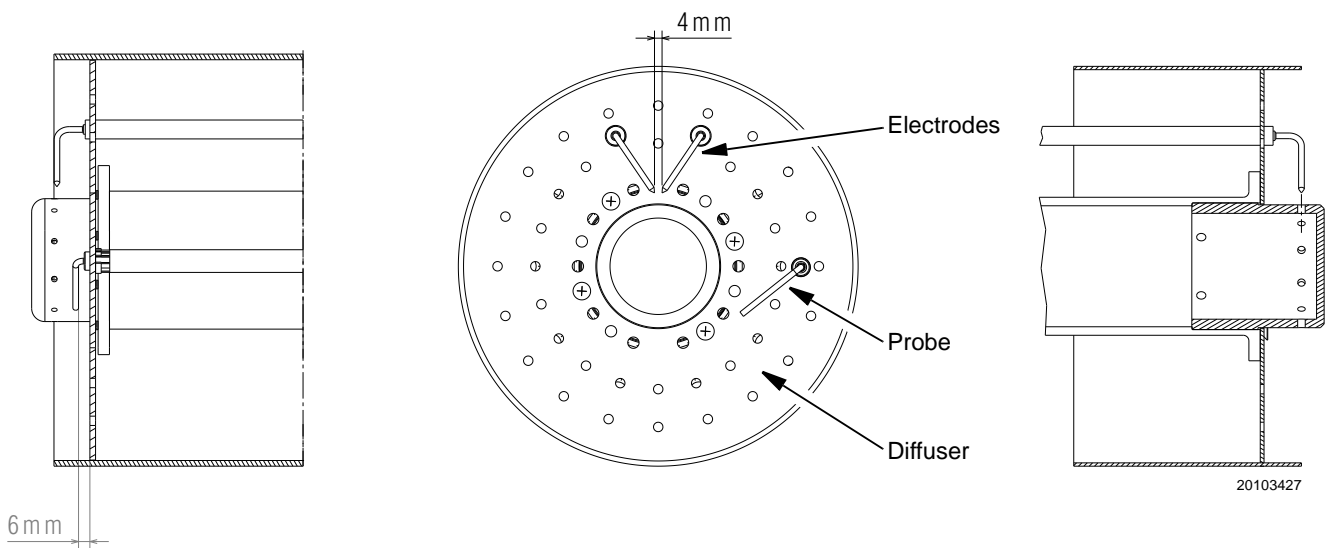

**Fig. 14**

**5.10 Combustion head adjustment**

The air damper servomotor 4)(Fig. 4 on page 11), beyond varying the air output according to the output demand, through a leverage varies the combustion head adjustment.

This system allows an optimum adjustment also at minimum firing rate.

Similarly to servomotor rotation, it is possible to vary the opening of the combustion head moving the tie-rod on the holes (5-6-7-8-10)(Fig. 15).

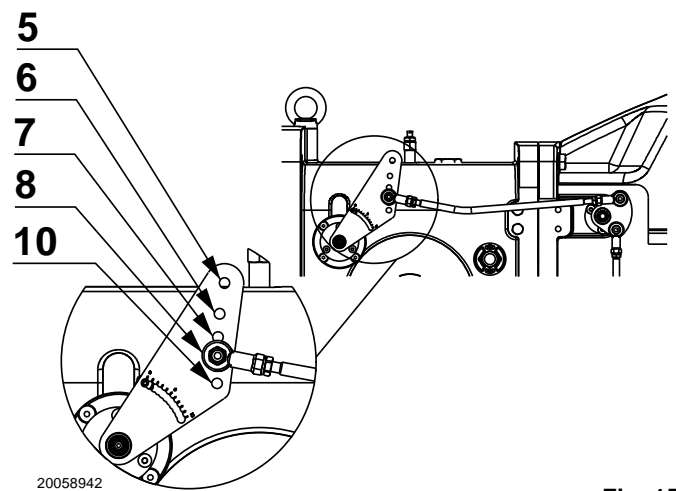

**Fig. 15**

The selection of the hole to be used is determined based on the maximum output requested, as illustrated in Tab. J.

In the factory, the adjustment is adjusted for the maximum stroke (hole 10, Fig. 15).



**WARNING**

The gas pipes leave the factory calibrated at notch 1.

The adjustment shown in Fig. 16 allows the gas pipes to be positioned in the best way for the application on which the burner is installed (e.g. boilers with flame inversion chamber).

	Leverage hole	Output (kW)	
		From	A
RS 1000	5	1100	4000
	5	4000	6600
	6	6600	8100
	8	8100	10100
RS 1200	5	1500	5500
	6	5500	7500
	8	7500	9650
	10	9650	11100

**Tab. J**

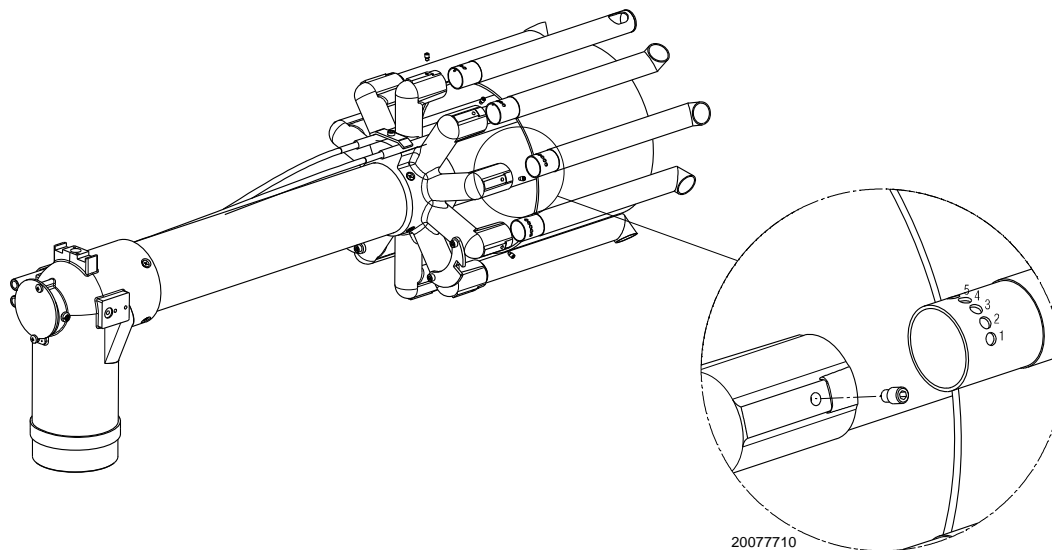

20077710

**Fig. 16**

**5.11 Gas feeding**



Explosion danger due to fuel leaks in the presence of a flammable source.

Precautions: avoid knocking, attrition, sparks and heat.

Make sure that the fuel interception tap is closed before performing any operation on the burner.



**WARNING**

The fuel supply line must be installed by qualified personnel, in compliance with current standards and laws.

**5.11.1 Gas feeding line**

Key (Fig. 17 - Fig. 18 - Fig. 19 - Fig. 20)

- 1 Gas input pipe
- 2 Manual valve
- 3 Vibration damping joint
- 4 Pressure gauge with pushbutton cock
- 5 Filter
- 6A Includes:
  - Filter
  - working valve
  - safety valve
  - pressure adjuster
- 6B Includes:
  - working valve
  - safety valve
  - pressure adjuster
- 6C Includes
  - safety valve
  - working valve
- 6D Includes:
  - safety valve
  - working valve
- 7 Minimum gas pressure switch
- 8 Leak detection device, supplied as an accessory or incorporated, based on the gas train code. In compliance with the EN 676 standard, the leak detection control is compulsory for burners with maximum outputs over 1200 kW.
- 9 Gasket, for "flanged" versions only
- 10 Pressure adjuster
- 11 Train-burner adaptor, supplied separately
- P2 Upstream pressure of valves/adjuster
- P3 Upstream pressure of the filter
- L Gas train supplied separately
- L1 The responsibility of the installer

**MBC "threaded"**

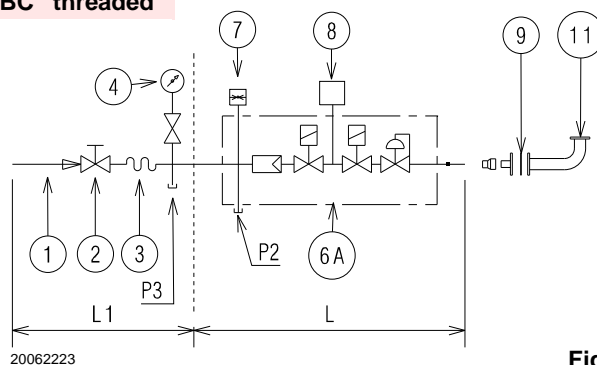

**Fig. 17**

**MBC "flanged"**

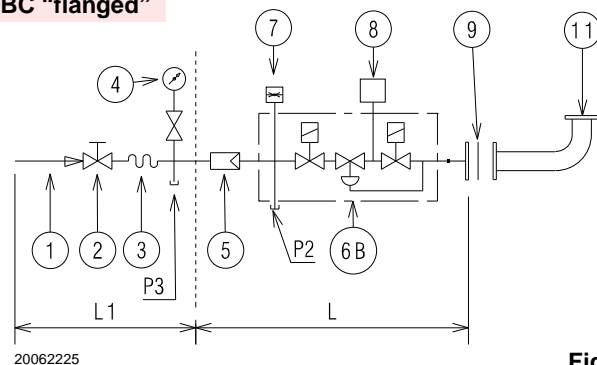

**Fig. 18**

**DMV "flanged or threaded"**

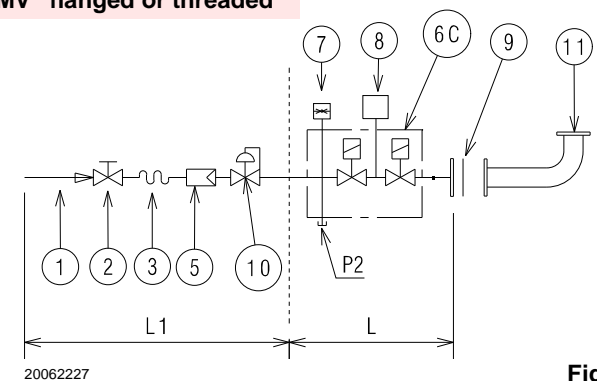

**Fig. 19**

**CB "flanged or threaded"**

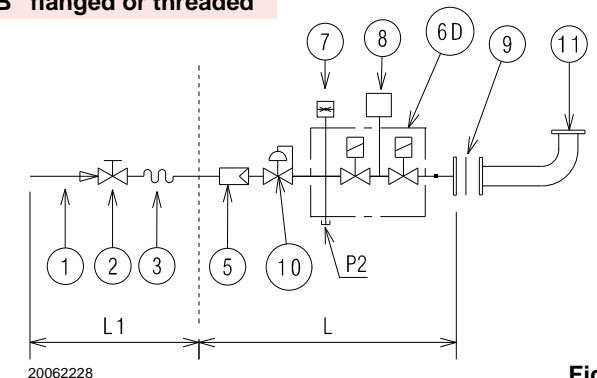

**Fig. 20**



**5.11.2 Gas train**

Type-approved in accordance with EN 676 and supplied separately from the burner.

To select the correct model of the gas train, refer to the “burner-gas train combination” manual supplied.

**5.11.3 Gas train installation**



Disconnect the electrical power using the main system switch.



Check that there are no gas leaks.



Beware of train movements: danger of crushing of limbs.



Make sure that the gas train is properly installed by checking for any fuel leaks.



The operator must use appropriate tools for installation.

The gas train is prearranged to be connected to the burner by the flange 1)(Fig. 21).

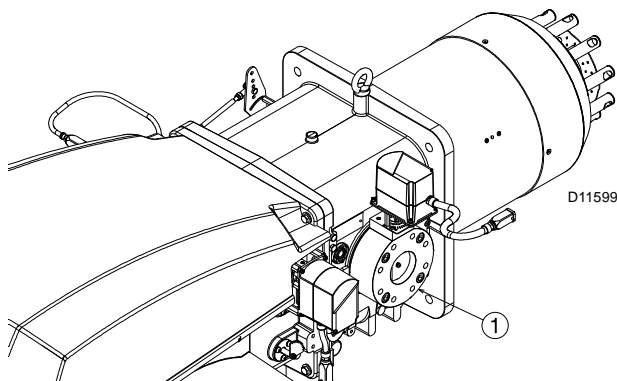

**Fig. 21**

**5.11.4 Gas pressure**

Tab. K indicates the pressure drop of the combustion head and the gas butterfly valve depending on the operating output of the burner.

	kW	1 Δp (mbar)		2 Δp (mbar)	
		G 20	G 25	G 20	G 25
<b>RS 1000/EV BLU</b>	4000	9.9	14.4	1.2	1.7
	4500	13.0	18.8	1.5	2.2
	5000	16.0	23.2	1.8	2.7
	5500	19.1	27.6	2.2	3.3
	6000	22.1	32.0	2.6	3.9
	6500	25.2	36.3	3.1	4.6
	7000	28.9	41.6	3.6	5.3
	7500	32.9	47.2	4.1	6.1
	8000	36.9	52.7	4.7	7.0
	8500	41.5	59.4	5.3	7.9
	9000	46.4	66.3	5.9	8.8
	9500	51.2	73.3	6.6	9.8
<b>RS 1200/EV BLU</b>	10000	56.0	80.2	7.3	10.9
	10100	57.0	81.6	7.5	11.1
	5500	18.2	26.6	2.2	3.3
	6000	22.1	32.1	2.6	3.9
	6500	26.0	37.6	3.1	4.6
	7000	29.9	43.2	3.6	5.3
	7500	33.8	48.7	4.1	6.1
	8000	38.6	55.4	4.7	7.0
	8500	43.4	62.1	5.3	7.9
	9000	48.2	68.8	6.0	8.8
	9500	53.1	75.5	6.6	9.8
	10000	58.6	83.1	7.4	10.9
10500	64.4	91.0	8.1	12.0	
11000	70.2	99.0	8.9	13.2	
11100	71.4	100.6	9.1	13.4	

**Tab. K**

The values shown in Tab. K refer to:

- Natural gas G 20 NCV 9.45 kWh/Sm<sup>3</sup> (8.2 Mcal/Sm<sup>3</sup>)
- Natural gas G 25 NCV 8.13 kWh/Sm<sup>3</sup> (7.0 Mcal/Sm<sup>3</sup>)

Column 1

Pressure drop on combustion head.

Gas pressure measured at the test point 1) (Fig. 22), with:

- combustion chamber at 0 mbar;
- burner working at maximum modulating output;
- combustion head set as on page 19.

Column 2

Pressure loss at gas butterfly valve 2)(Fig. 22) with maximum opening: 90°.

To calculate the approximate output at which the burner operates:

- subtract the combustion chamber pressure from the gas pressure measured at test point 1)(Fig. 22).
- Find, in Tab. K related to the burner concerned, the pressure value closest to the result of the subtraction.
- Read off the corresponding output on the left.



**Example RS 1000/EV BLU with G20 natural gas:**

Maximum modulating output operation

Gas pressure at test point 1) (Fig. 22) = 59.2 mbar  
 Pressure in combustion chamber = 10 mbar  
 $59.2 - 10 = 49.2$  mbar

A pressure of 49.2 mbar, column 1, corresponds in Tab. K to an output of 9000 kW.

This value serves as a rough guide; the effective output must be measured at the gas meter.

To calculate the required gas pressure at test point 1) (Fig. 22), set the maximum modulating output required from the burner operation:

- find the nearest output value in Tab. K for the burner in question.
- read, on the right (column 1), the pressure at the test point 1) (Fig. 22).
- Add this value to the estimated pressure in the combustion chamber.

**Example RS 1000/EV BLU with G20 natural gas:**

Maximum modulating output operation

Gas pressure at an output of 9000 kW = 49.2 mbar  
 Pressure in combustion chamber = 10 mbar  
 $49.2 + 10 = 59.2$  mbar

Pressure required at test point 1)(Fig. 22).

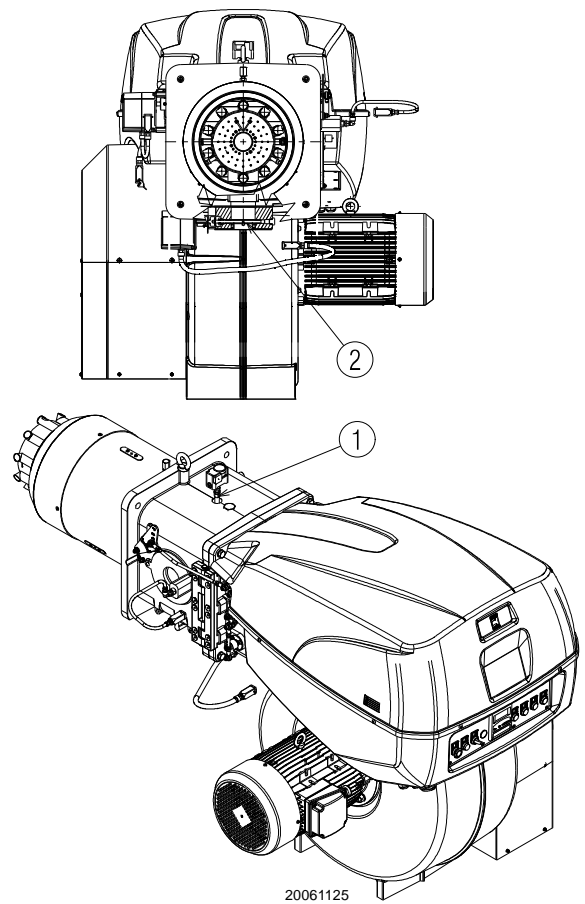

**Fig. 22**

**5.12 Electrical wiring**

**Notes on safety for the electrical wiring**



- The electrical wiring must be carried out with the electrical supply disconnected.
- Electrical wiring must be made in accordance with the regulations currently in force in the country of destination and by qualified personnel. Refer to the wiring diagrams.
- The manufacturer declines all responsibility for modifications or connections different from those shown in the wiring diagrams
- Check that the electrical supply of the burner corresponds to that shown on the identification label and in this manual.
- The burner has been type-approved for intermittent use (FS1). This means they should compulsorily be stopped at least once every 24 hours to enable the control box to perform checks of its own start-up efficiency. Normally, burner stopping is guaranteed by the boiler's thermostat/pressure switch. If this is not the case, a time switch should be fitted in series to TL to stop the burner at least once every 24 hours. Refer to the wiring diagrams.
- The burner is factory set for FS1 operation (1 stop every 24 hours); it can be converted to FS2 operation (continuous - 1 stop every 72 hours), by changing the parameters using the menu of the AZL Display.
- The electrical safety of the device is obtained only when it is correctly connected to an efficient earthing system, made according to current standards. It is necessary to check this fundamental safety requirement. In the event of doubt, have the electrical system checked by qualified personnel. Do not use the gas tubes as an earthing system for electrical devices.
- The electrical system must be suitable for the maximum power absorption of the device, as indicated on the label and in the manual, checking in particular that the section of the cables is suitable for that level of power absorption.
- For the main power supply of the device from the electricity mains:
  - do not use adapters, multiple sockets or extensions;
  - use a multiple pole switch with at least a 3mm gap between the contacts (overvoltage category III), as envisaged by the present safety standards.
- Do not touch the device with wet or damp body parts and/or in bare feet.
- Do not pull the electric cables.

Before carrying out any maintenance, cleaning or checking operations:



Disconnect the electrical supply from the burner by means of the main system switch.



Close the fuel interception tap.



Avoid condensate, ice and water leaks from forming.

If the hood is still present, remove it and proceed with the electrical wiring according to the wiring diagrams.

Use flexible cables in compliance with the EN 60 335-1 standard.

**5.12.1 Supply cables and external connections passage**

All the cables to be connected to the burner should be passed through cable grommets, as shown in Fig. 23.



To guarantee the protection level of the burner, it is necessary to close any holes that are still free, using the plugs supplied.

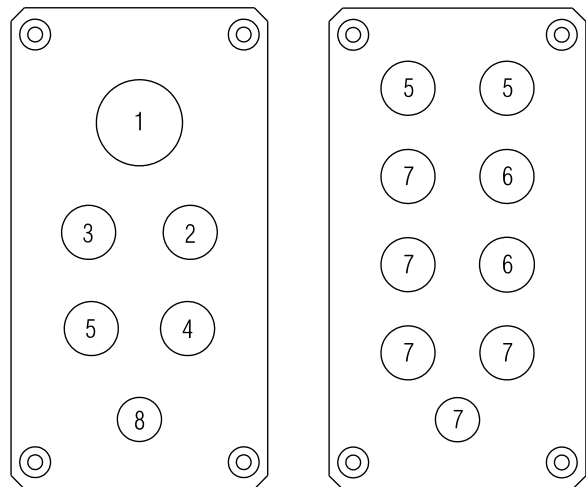

20096726

**Fig. 23**

**Key (Fig. 23)**

- 1 Electrical supply
- 2 Minimum gas pressure switch
- 3 Pressure switch for VPS gas valve leak detection
- 4 Gas train
- 5 Consents/Safety
- 6 Available
- 7 Plug
- 8 Revolution sensor



After carrying out maintenance, cleaning or checking operations, reassemble the hood and all the safety and protection devices of the burner.

### 5.12.2 Shielding the connections



**WARNING**

For the burner to operate correctly, where required, it is necessary to shield the connections.

To shield the motor connection, proceed as follows:

- to access the motor casing, loosen the four screws 1)(Fig. 24) and remove the cover 2);
- remove the shielded coupling 3) screwed to the motor casing.



**CAUTION**

To make the correct shielding, it is important to bear in mind the necessary length of the connections inside the motor casing.

- Shield the cable 4) running from the VSD (inverter), as shown in Fig. 25 and using the coupling 6);
- install the cable 4) with its relative coupling on the motor casing, fixing it carefully in place with the ring nut 5)(Fig. 24).
- Carry out the motor connection as shown in the wiring diagrams.
- Fix the grommets/cable terminals of the connections securely and tidily to the terminal board of the motor.
- Make a final visual check, then close the motor casing by tightening the 4 screws 1)(Fig. 24).

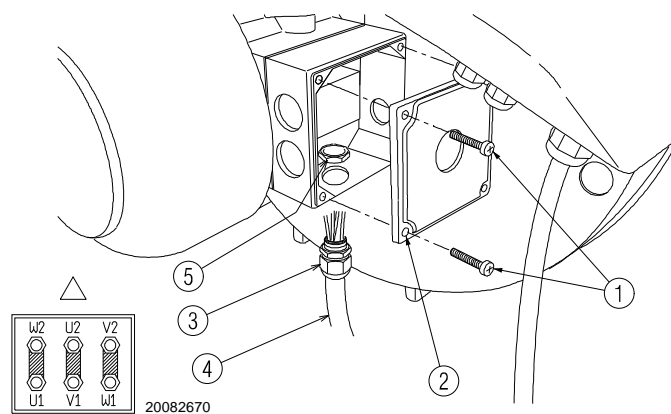

**Fig. 24**

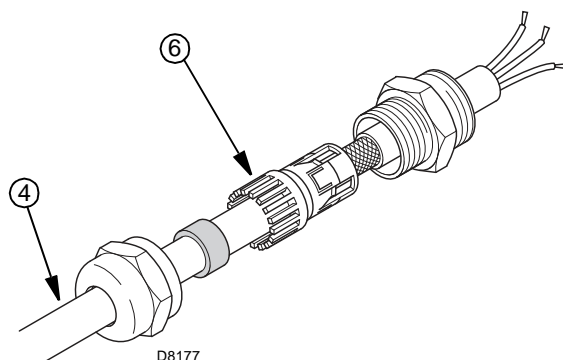

**Fig. 25**

### 5.12.3 Motor rotation

As the burner is not fitted with a phase sequence checking device, the motor rotation may be incorrect.



**WARNING**

As soon as the burner starts up, go in front of the fan motor cooling fan and check it is rotating anti-clockwise (Fig. 26).

If this is not the case:

- turn the burner switch to position "0" (OFF) and wait for the control box to carry out the switch-off phase;
- disconnect the power supply to the main panel;
- invert the phases on the three-phase power supply.



**DANGER**

This operation must be carried out with the electrical supply disconnected.

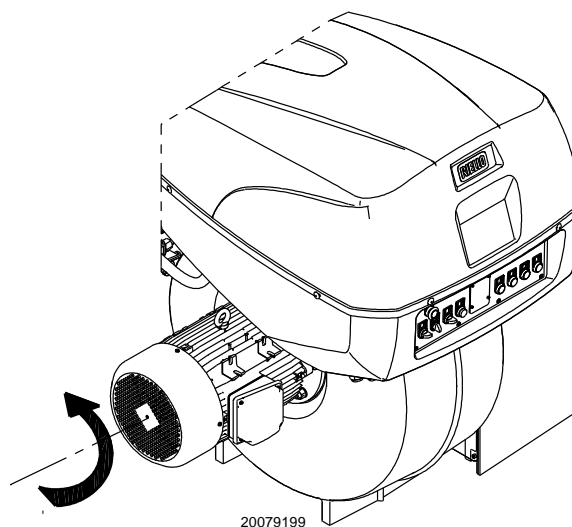

**Fig. 26**

**6 Start-up, calibration and operation of the burner**

**6.1 Notes on safety for the first start-up**



The first start-up of the burner must be carried out by qualified personnel, as indicated in this manual and in compliance with the standards and regulations of the laws in force.



Check the correct working of the adjustment, command and safety devices.

**6.2 Adjustments prior to ignition**

The adjustments to be carried out are:

- Slowly open the manual valves situated upstream from the gas train.
- Adjust the minimum gas pressure switch (Fig. 32) to the start of the scale.
- Adjust the maximum gas pressure switch (Fig. 31) to the end of the scale.
- Adjust the air pressure switch (Fig. 30) to the start of the scale.
- Purge the air from the gas line.  
We recommend using a plastic tube routed outside the building and to purge air until gas is smelt.
- Fit a U-type pressure gauge or a differential pressure gauge (Fig. 27), with socket (+) on the gas pressure of the pipe coupling and (-) in the combustion chamber.  
Used to approximately calculate the MAX burner output.
- Connect two lamps or testers to the two gas line solenoids to check the exact moment in which voltage is supplied.  
This operation is unnecessary if each of the two solenoid valves is equipped with a pilot light that signals voltage passing through.



Before starting up the burner, it is good practice to adjust the gas train so that ignition takes place in conditions of maximum safety, i.e. with gas delivery at the minimum.

**6.2.1 Revolution sensor**

This is located inside the motor cover and measures the revolution using the reading plate.

The revolution sensor is factory set.



To ensure that the burner operates correctly, the revolution sensor must be positioned as shown in Fig. 28.

If it needs adjusting, see the section Positioning the revolution sensor.

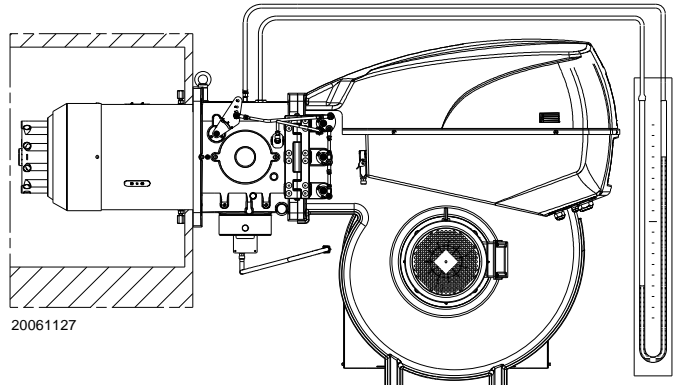

**Fig. 27**

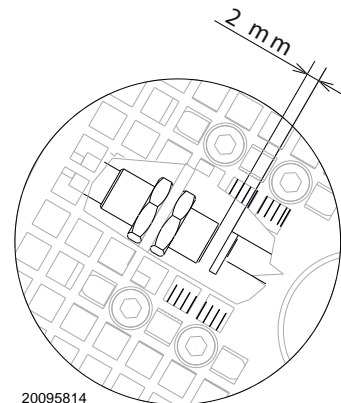

**Fig. 28**

### 6.3 Burner start-up

Close the remote controls and position the selector 1)(Fig. 29) to "AUTO".

Make sure that the lights or testers connected to the solenoids, or the pilot lights on the solenoids themselves, indicate that no voltage is present.

If voltage is present, stop the burner immediately and check the electrical connections.

When the limit thermostat (TL) is closed, the "HEAT REQUEST" 2)(Fig. 29) signal must be on and the burner starts the starting cycle.

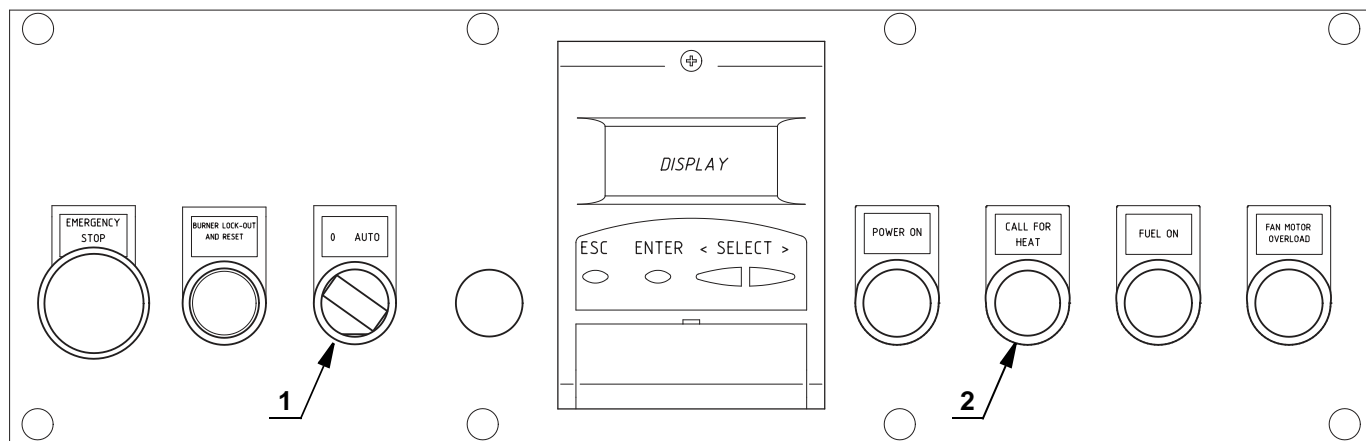

D11968

Fig. 29

### 6.4 Burner ignition

Once the above steps are complete, the burner should light.

If the motor starts up, but the flame does not appear and the control box goes into lockout, reset it and wait for a new ignition attempt.

If ignition is still not achieved, it may be that gas is not reaching the combustion head within the safety time period of 3 seconds. In this case increase gas ignition delivery.

The arrival of gas at the pipe coupling is indicated by the U-type pressure gauge (Fig. 27).

If further burner lockouts occur, refer to the "Release procedure" given in the equipment manual supplied.

Once the burner has ignited, proceed with the global adjustment of the burner.

### 6.5 Combustion air adjustment

Fuel/combustion air synchronisation is done with the relevant servomotors (air and gas) by logging a calibration curve by means of the electronic cam.

It is advisable, to reduce the loss and for a wide calibration field, to adjust the servomotors to the maximum of the output used, the nearest possible to the maximum opening (90°).

On the gas butterfly valve, fuel step according to the burner output required, with servomotor completely open, is carried out by the pressure stabiliser placed on the gas train.

The values given in Tab. L may be used as guidelines for correctly calibrating combustion.

EN 676		Air excess		CO
		Max. output $\lambda \leq 1.2$	Max. output $\lambda \leq 1.3$	
GAS	Theoretical max. CO <sub>2</sub> 0 % O <sub>2</sub>	CO <sub>2</sub> % Calibration		mg/kWh
		$\lambda = 1.2$	$\lambda = 1.3$	
G 20	11.7	9.7	9	≤ 1000
G 25	11.5	9.5	8.8	≤ 1000
G 30	14.0	11.6	10.7	≤ 1000
G 31	13.7	11.4	10.5	≤ 1000

Tab. L

### 6.5.1 Air / gas adjustment and output modulation

The air/gas regulator and output modulation system equipping **RS** series burners performs a number of integrated functions to optimise burner function, in both individual installations and in combination with other units (e.g. double furnace boiler or multiple heat generators in parallel).

The basic system functions control:

- 1 The dosage of the air and fuel through positioning using direct servocommands of the relevant valves eliminating the possible play in the calibration systems with mechanical cam lever mechanisms, used on traditional modulating burners.
- 2 The modulation of the burner output in accordance with the load required by the system, with maintenance of the pressure or temperature of the boiler at the operating values set.
- 3 The sequence (cascade adjustment) of more than one boiler through the suitable connection of the various units and the activation of the internal software of the individual systems (option).

Further interfaces and communication functions with computers, for remote control or integration in central supervision systems are available on the basis of the configuration of the system.



**WARNING**

The first start up and every further internal setting operation of the adjustment system or the expansion of the base functions require access by means of password and are to be carried out by service personnel who are especially trained for the internal programming of the instrument and the specific application created with this burner.

The first start-up and curve synchronisation manual is supplied with the burner.

At request, the complete manual for the control and setting of all parameters is available.

**6.6 Pressure switch adjustment**

**6.6.1 Air pressure switch - check CO**

Adjust the air pressure switch after performing all other burner adjustments with the air pressure switch set to the start of the scale (Fig. 30).

With the burner working at MIN output, insert a combustion analyser in the stack, slowly close the suction inlet of the fan (for example, with a piece of cardboard) until the CO value does not exceed 100 ppm.

Slowly turn the appropriate knob clockwise until the burner goes into lockout.

Check the indication of the arrow pointing upwards on the graduated scale.

Turn the knob clockwise again, until the value shown on the graduated scale corresponds with the arrow pointing downwards, and so recovering the hysteresis of the pressure switch (shown by the white mark on a blue background, between the two arrows). Now check the correct start-up of the burner.

If the burner locks out again, turn the knob anticlockwise a little bit more.

**6.6.2 Maximum gas pressure switch**

Adjust the maximum gas pressure switch after performing all other burner adjustments with the maximum gas pressure switch set to the end of the scale (Fig. 31).

With the burner operating at maximum output, lower the adjustment pressure by slowly turning the relative knob anticlockwise until the burner locks out.

Now turn the knob clockwise by 2 mbar and repeat the start-up of the burner.

If the burner locks out again, turn the knob clockwise again by 1 mbar.

**6.6.3 Minimum gas pressure switch**

Adjust the minimum gas pressure switch after performing all the other burner adjustments with the pressure switch set to the start of the scale (Fig. 32).

With the burner operating at maximum output, increase adjustment pressure by slowly turning the relative knob clockwise until the burner stops.

Now turn the knob anticlockwise by 2 mbar and repeat burner start-up to ensure it is uniform.

If the burner locks out again, turn the knob anticlockwise again by 1 mbar.

**6.6.4 PVP pressure switch kit**

Adjust the pressure switch for the leak detection control (PVP kit) (Fig. 33) according to the instructions supplied with the kit.



**Fig. 30**

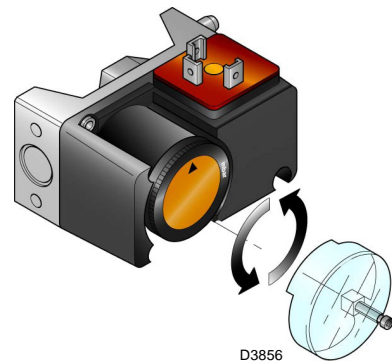

**Fig. 31**

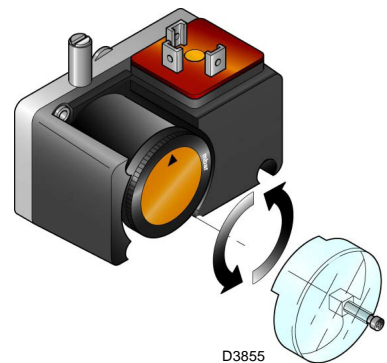



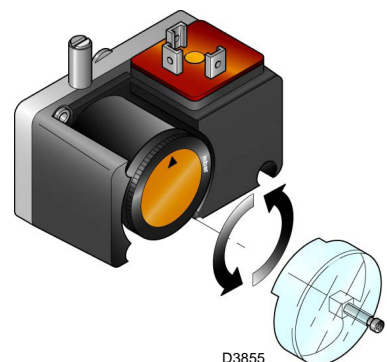

**Fig. 32**



**Fig. 33**

**6.7 Final checks (with burner operating)**

<ul style="list-style-type: none"> <li>➤ Open the thermostat/pressure switch TL</li> <li>➤ Open the thermostat/pressure switch TS</li> </ul>		The burner must stop
<ul style="list-style-type: none"> <li>➤ Turn the gas maximum pressure switch knob to the minimum end of scale position</li> <li>➤ Turn the air pressure switch to the maximum end of scale position</li> </ul>		The burner must stop in lockout
<ul style="list-style-type: none"> <li>➤ Turn off the burner and cut off the power</li> <li>➤ Disconnect the minimum gas pressure switch connector</li> </ul>		The burner must not start
<ul style="list-style-type: none"> <li>➤ Disconnect the ionisation probe wire</li> </ul>		The burner must stop in lockout due to ignition failure

**Tab. M**



**WARNING**

Make sure that the mechanical locking systems on the various adjustment devices are fully tightened.



## 7 Maintenance

### 7.1 Notes on safety for the maintenance

The periodic maintenance is essential for the good operation, safety, yield and duration of the burner.

It allows you to reduce consumption and polluting emissions and to keep the product in a reliable state over time.



The maintenance interventions and the calibration of the burner must only be carried out by qualified, authorised personnel, in accordance with the contents of this manual and in compliance with the standards and regulations of current laws.

Before carrying out any maintenance, cleaning or checking operations:



Disconnect the electrical supply from the burner by means of the main system switch.



Close the fuel interception tap.



Wait for the components in contact with heat sources to cool down completely.

### 7.2 Maintenance programme

#### 7.2.1 Maintenance frequency



The gas combustion system should be checked at least once a year by a representative of the manufacturer or another specialised technician.

#### 7.2.2 Checking and cleaning



The operator must use the required equipment during maintenance.

#### Combustion

Carry out an analysis of the combustion discharge gases. Significant differences with respect to the previous check indicate the points where more care should be exercised during maintenance.

#### Combustion head

Open the burner and make sure that all components of the combustion head are in good condition, not deformed by the high temperatures, free of impurities from the surroundings and correctly positioned.

#### Fan

Check to make sure that no dust has accumulated inside the fan or on its blades, as this condition will cause a reduction in the air flow rate and provoke polluting combustion.

#### Burner

Clean the outside of the burner.

#### Boiler

Clean the boiler as indicated in its accompanying instructions in order to maintain all the original combustion characteristics intact, especially the flue gas temperature and combustion chamber pressure.

#### Flame presence check

The burner is fitted with an ionisation probe to check that a flame is present.

The minimum current for control box operation is 6  $\mu\text{A}$ . The burner provides a much higher current, so controls are not normally required.

However, whenever you want to measure the ionisation current, you need to remove the bridge between terminals ION1-ION2 (Fig. 34) on the terminal board and insert a microamperometer for continuous current with a 100  $\mu\text{A}$  base scale.

Carefully check polarities!

As the normal flame variations produce ionisation current values that are sometimes unstable, you are advised to always maintain a current of at least 20  $\mu\text{A}$  while making the calibrations. Once the operation is finished, put back the bridge between the terminals.

#### NOTE:

reaching the maximum output, the flame root tends to increase and the ionisation current consequently decreases. In relation to this, the high output measurements are very important.

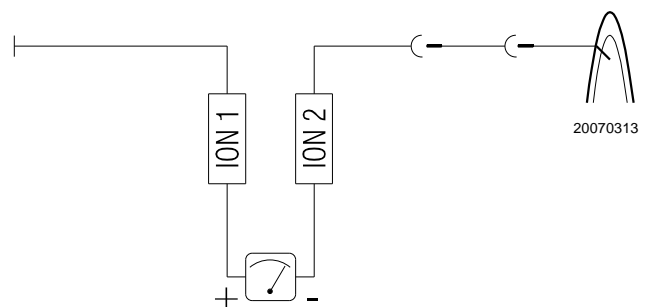

Fig. 34

#### Gas leaks

Make sure that there are no gas leaks on the pipes between the gas meter and the burner.

#### Gas filter

Replace the gas filter when it is dirty.

### Combustion

If the combustion values found at the start of the intervention do not satisfy current standards or anyway indicate a poor state of combustion (consult the table below), contact the Technical Assistance Service for the necessary adjustments.

### 7.2.3 Positioning the revolution sensor



**WARNING**

In the event the revolution sensor is malfunctioning or needs replacing, check/reset its position inside the fan motor cover.

To adjust, proceed as follows:

- loosen the screws 3) and rest the sensor against the plate of the disc 2);
- referring to the scale 4) draw back the revolution sensor by about a notch so that there is a distance of about 2 mm from the disc plate 2).

Key (Fig. 35)

- 1 Revolution sensor
- 2 Disc
- 3 Screw
- 4 Scale

EN 676		Air excess		CO
		Max. output $\lambda \leq 1.2$	Max. output $\lambda \leq 1.3$	
GAS	Theoretical max. CO <sub>2</sub> 0 % O <sub>2</sub>	CO <sub>2</sub> % Calibration		mg/kWh
		$\lambda = 1.2$	$\lambda = 1.3$	
G 20	11.7	9.7	9	≤ 1000
G 25	11.5	9.5	8.8	≤ 1000
G 30	14.0	11.6	10.7	≤ 1000
G 31	13.7	11.4	10.5	≤ 1000

**Tab. N**

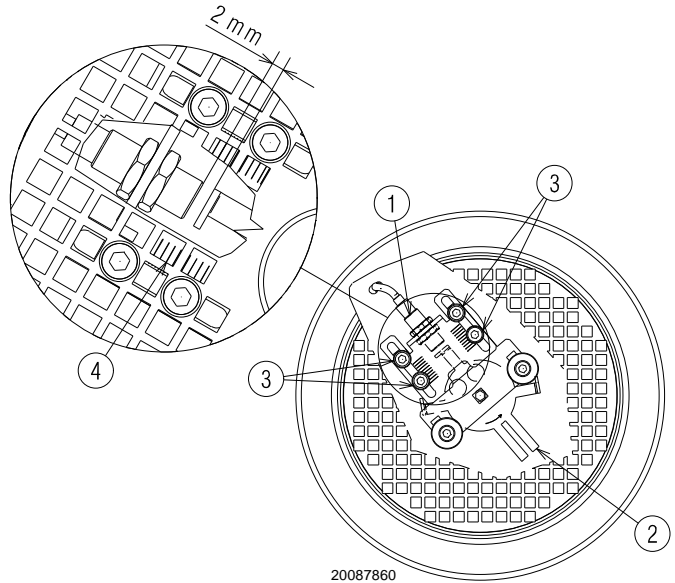

**Fig. 35**

### 7.3 Opening the burner



Disconnect the electrical supply from the burner by means of the main system switch.



Close the fuel interception tap.



Wait for the components in contact with heat sources to cool down completely.

- Remove the tie-rod 1)(Fig. 36) of the head movement lever, undoing the nut 2);
- disconnect the socket 4) of the gas servomotor;
- disconnect the connection to the gas pressure switch;
- remove the screws 3);
- partially open the burner;
- disconnect the electrodes and the ionisation probe.
- At this point, it is possible to open the burner on the hinge.

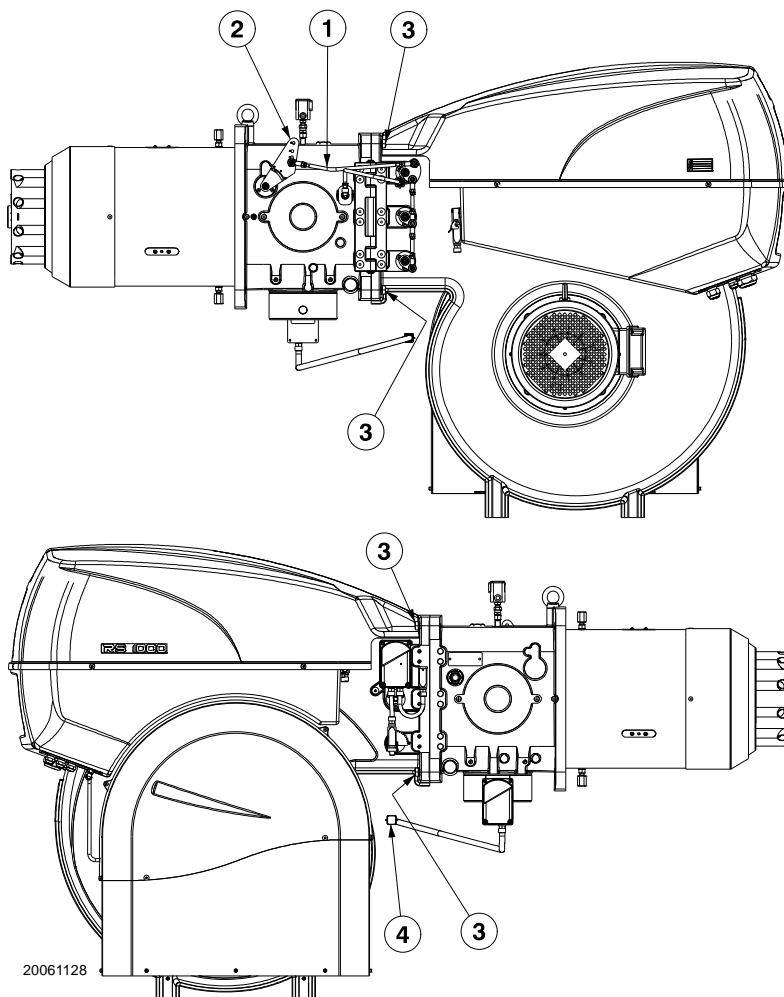

Fig. 36

### 7.4 Closing the burner

Refit following the steps described but in reverse order; refit all burner components as they were originally assembled.



After carrying out maintenance, cleaning or checking operations, reassemble the hood and all the safety and protection devices of the burner.

**8** **Faults - Probable causes - Solutions**

If faults arise in ignition or operations, the burner performs a “safety stop”, which is signalled by the red burner lockout LED.

The display visualises alternately the lockout code and the relative diagnostic. To reset the start-up conditions, refer to the “Reset procedure” indicated in the control box manual supplied.

When the burner starts again, the red LED goes out and the control box is reset.

**WARNING**

In the event of a burner lockout, more than two consecutive burner reset operations could cause damage to the installation. On the third lockout, contact the Aftersales Service.

**DANGER**

If further lockouts or burner faults occur, interventions must only be made by qualified, authorised personnel (as indicated in this manual, and in compliance with the laws and regulations currently in force).

**A Appendix - Accessories****Probe for checking temperature/pressure**

Parameter to be checked		Probe	
	Adjustment field	Type	Code
Temperature	- 100...+ 500°C	PT 100	3010110
Pressure	0...2.5 bar	Output probe 4....20 mA	3010213
	0...16 bar		3010214

**Probe for checking the air/combustion fume temperature**

Parameter to be checked		Probe	
	Adjustment field	Type	Code
Temperature	- 100...+ 500°C	PT 1000/Ni1000	3010377

**Inverter (VSD) kit**

Burner	Power supply	Inverter Output	Code
RS 1000/EV BLU	3Ph/400V/50Hz	22 kW	3090913
RS 1200/EV BLU	3Ph/400V/50Hz	30 kW	20030338



The use of inverters other than those indicated by the Manufacturer may lead to burner failure and, in extreme cases, a potential risk of harm to people and damage to property.

The Manufacturing company shall not be liable for any such damage arising from non-observance of the requirements contained in this manual.

**O<sub>2</sub> kit**

Burner	Code
RS 1000/EV BLU RS 1200/EV BLU	20045187

**Software interface kit**

Burner	Code
RS 1000/EV BLU RS 1200/EV BLU	3010388

**Soundproofing box kit**

Burner	Code
RS 1000/EV BLU RS 1200/EV BLU	3010401

**AZL kit (display and operating unit) (Russia only)**

Burner	Code
RS 1000/EV BLU RS 1200/EV BLU	3010469

**Pressure switch kit for leak detection control (supplied as standard)**

---

Burner	Code
RS 1000/EV BLU RS 1200/EV BLU	3010344

**Gas trains in compliance with EN 676**

---

Please refer to manual.

**B Appendix - Electrical panel layout**

<b>1</b>	<b>Index of layouts</b>
<b>2</b>	Indication of references
<b>3</b>	Layout of unifilar output
<b>4</b>	LMV52... operational layout
<b>5</b>	LMV52... operational layout
<b>6</b>	LMV52... operational layout
<b>7</b>	LMV52... operational layout
<b>8</b>	LMV52... operational layout
<b>9</b>	LMV52... operational layout
<b>10</b>	LMV52... operational layout
<b>11</b>	LMV52... operational layout
<b>12</b>	PLL52.../QGO20... operational layout
<b>13</b>	Electrical connections set by installer
<b>14</b>	Electrical connections set by installer
<b>15</b>	PLL52.../QGO20... operational layout

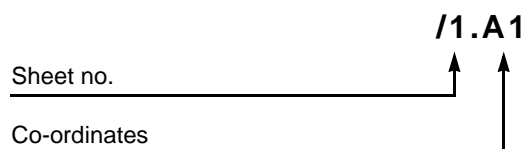
**2 Indication of references**

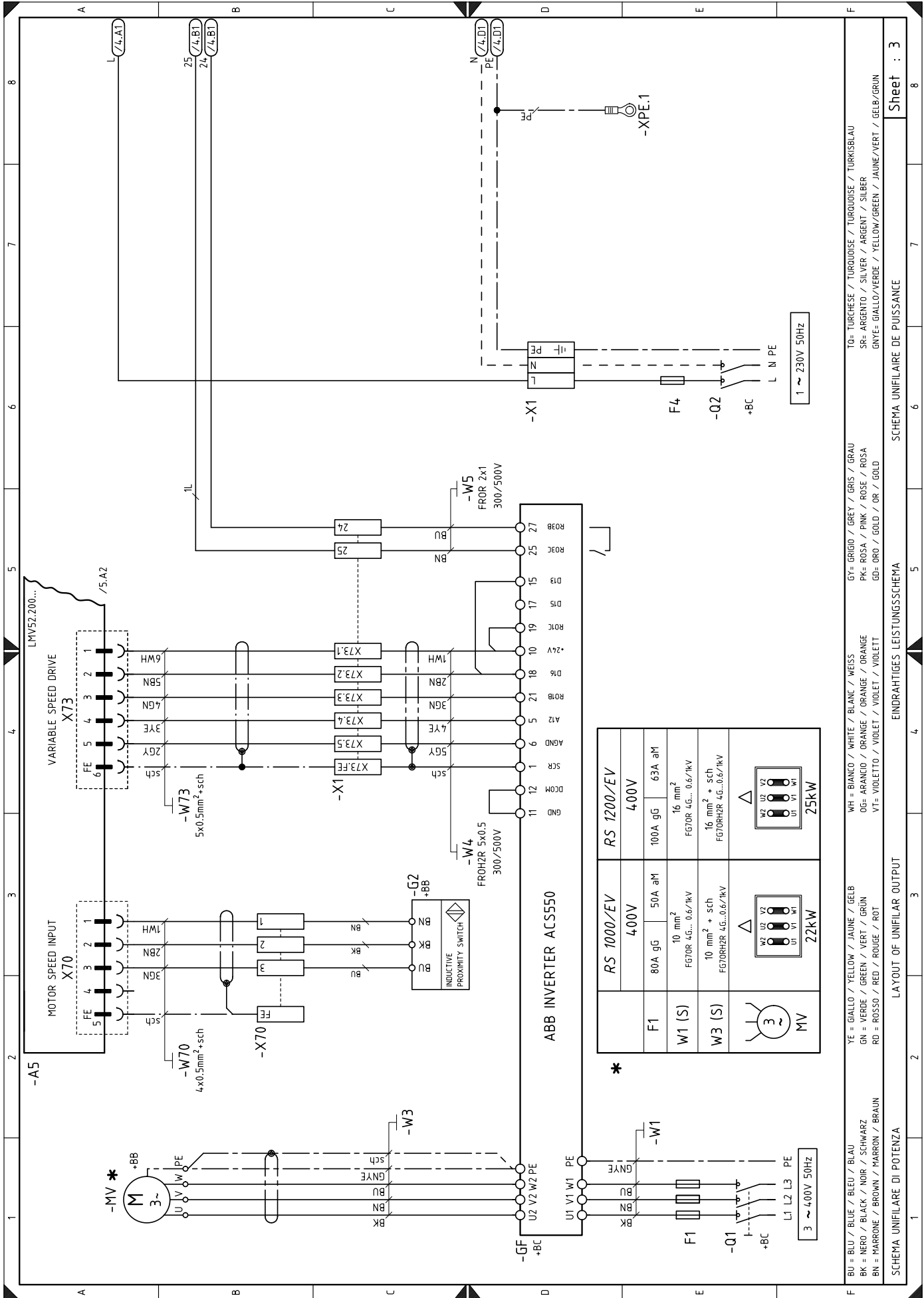

TO= TURCHESE / TURQUOISE / TURKOISE / TURKISBLAU  
 SR= ARGENTO / SILVER / ARGENT / SILBER  
 GNYE= GIALLO/VERDE / YELLOW/GREEN / JAUNE/VERT / GELB/GRUN

GY= GRIGIO / GREY / GRIS / GRAU  
 PK= ROSA / PINK / ROSE / ROSA  
 GD= ORO / GOLD / OR / GOLD

WH = BIANCO / WHITE / BLANC / WEISS  
 OG= ARANCIO / ORANGE / ORANGE / ORANGE  
 VT= VIOLETTO / VIOLET / VIOLET / VIOLETT

YE = GIALLO / YELLOW / JAUNE / GELB  
 GN = VERDE / GREEN / VERT / GRUN  
 RD = ROSSO / RED / ROUGE / ROT

BU = BLU / BLUE / BLEU / BLAU  
 BK = NERO / BLACK / NOIR / SCHWARZ  
 BN = MARRONE / BROWN / MARRON / BRAUN

SCHEMA UNIFILARE DI POTENZA  
 LAYOUT OF UNIFILAR OUTPUT  
 ENDRAHTIGES LEISTUNGSSCHEMA  
 SCHEMA UNIFILAIRE DE PUISSANCE

Sheet : 3



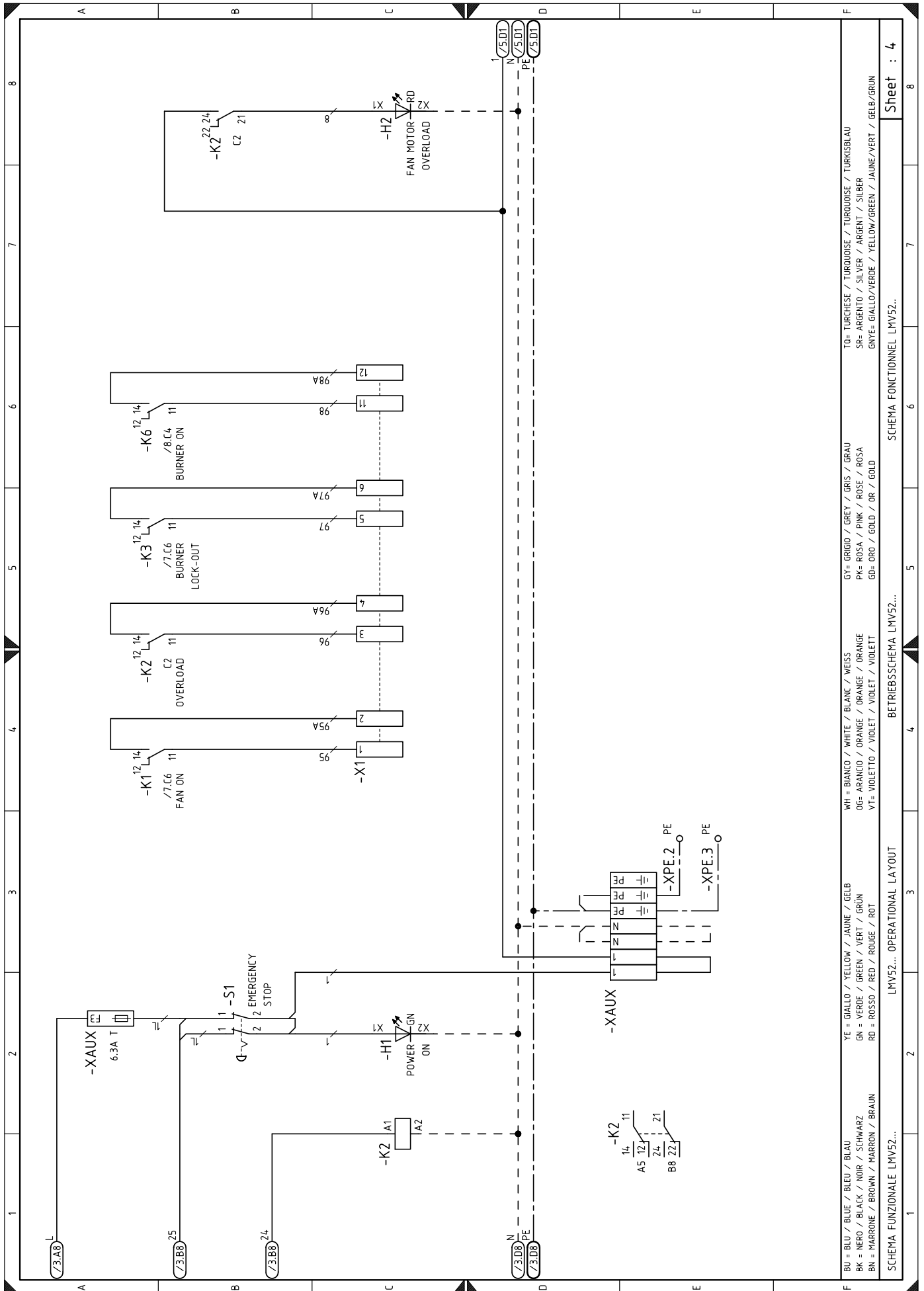



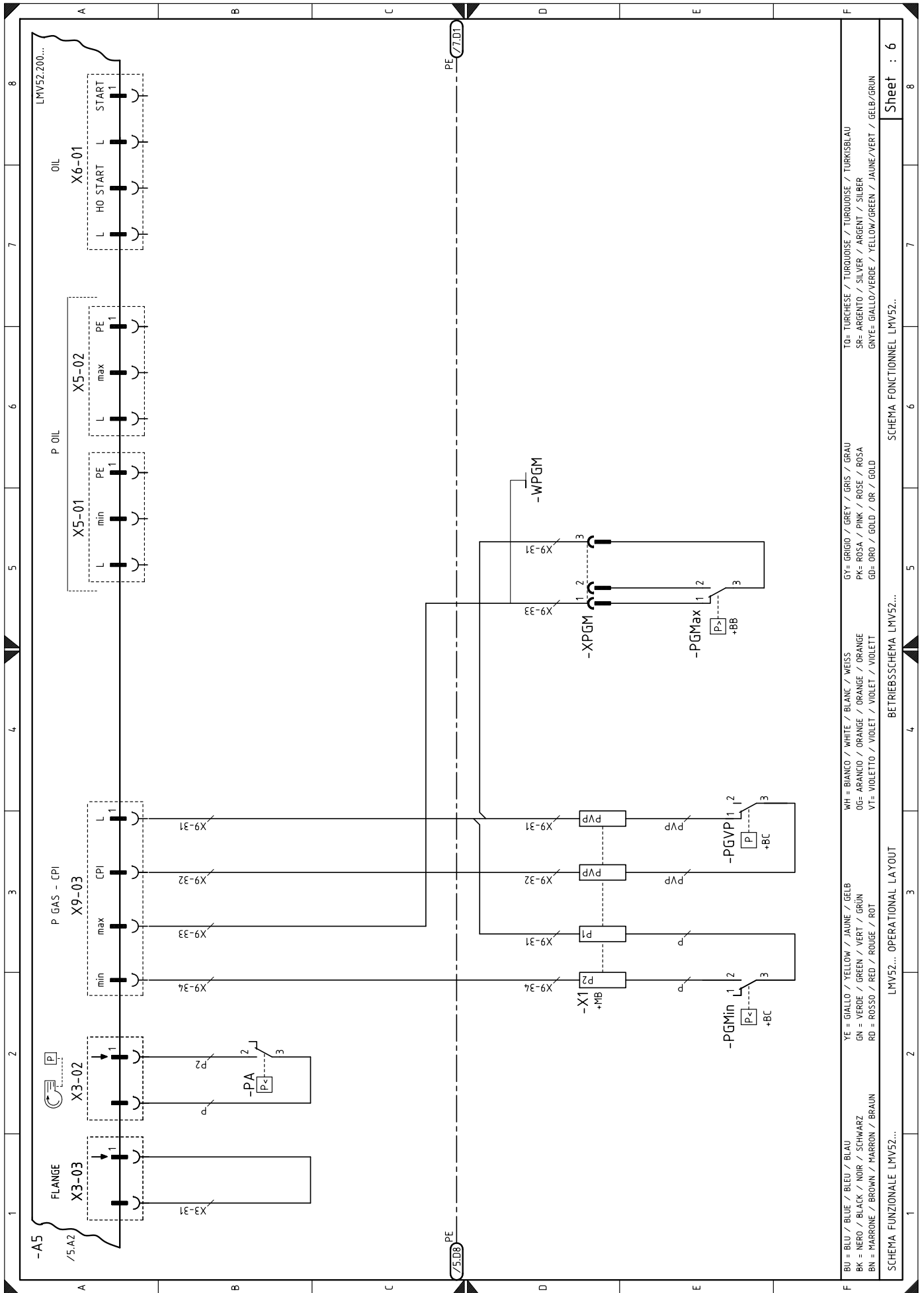

BU = BLU / BLUE / BLEU / BLAU	YE = GIALLO / YELLOW / JAUNE / GELB	WH = BIANCO / WHITE / BLANC / WEISS	GY = GRIGIO / GREY / GRIS / GRAU	TO = Turchese / TURQUOISE / TURKOISE / TURKSBLAU
BK = NERO / BLACK / NOIR / SCHWARZ	GN = VERDE / GREEN / VERT / GRÜN	OG = ARANCIO / ORANGE / ORANGE / ORANGE	PK = ROSA / PINK / ROSE / ROSA	SR = ARGENTO / SILVER / ARGENT / SILBER
BN = MARRONE / BROWN / MARRON / BRAUN	RD = ROSSO / RED / ROUGE / ROT	VT = VIOLETTA / VIOLET / VIOLET / VIOLETT	GD = ORO / GOLD / OR / GOLD	GNYE = GIALLO/VERDE / YELLOW/GREEN / JAUNE/VERT / GELB/GRÜN

SCHEMA FUNZIONALE LMV52... OPERATIONAL LAYOUT  
 SCHEMA FONCTIONNEL LMV52...  
 Sheet : 6





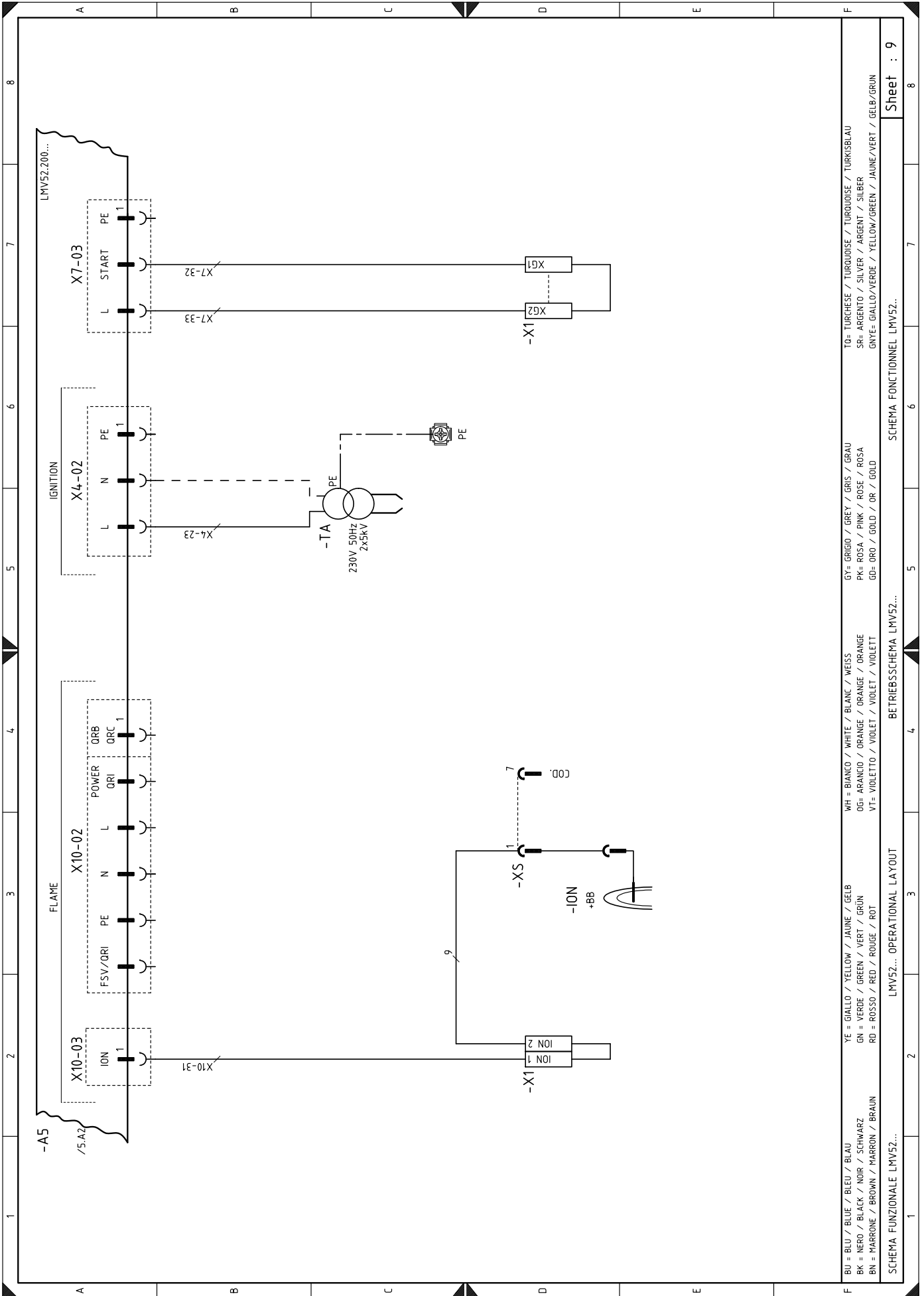

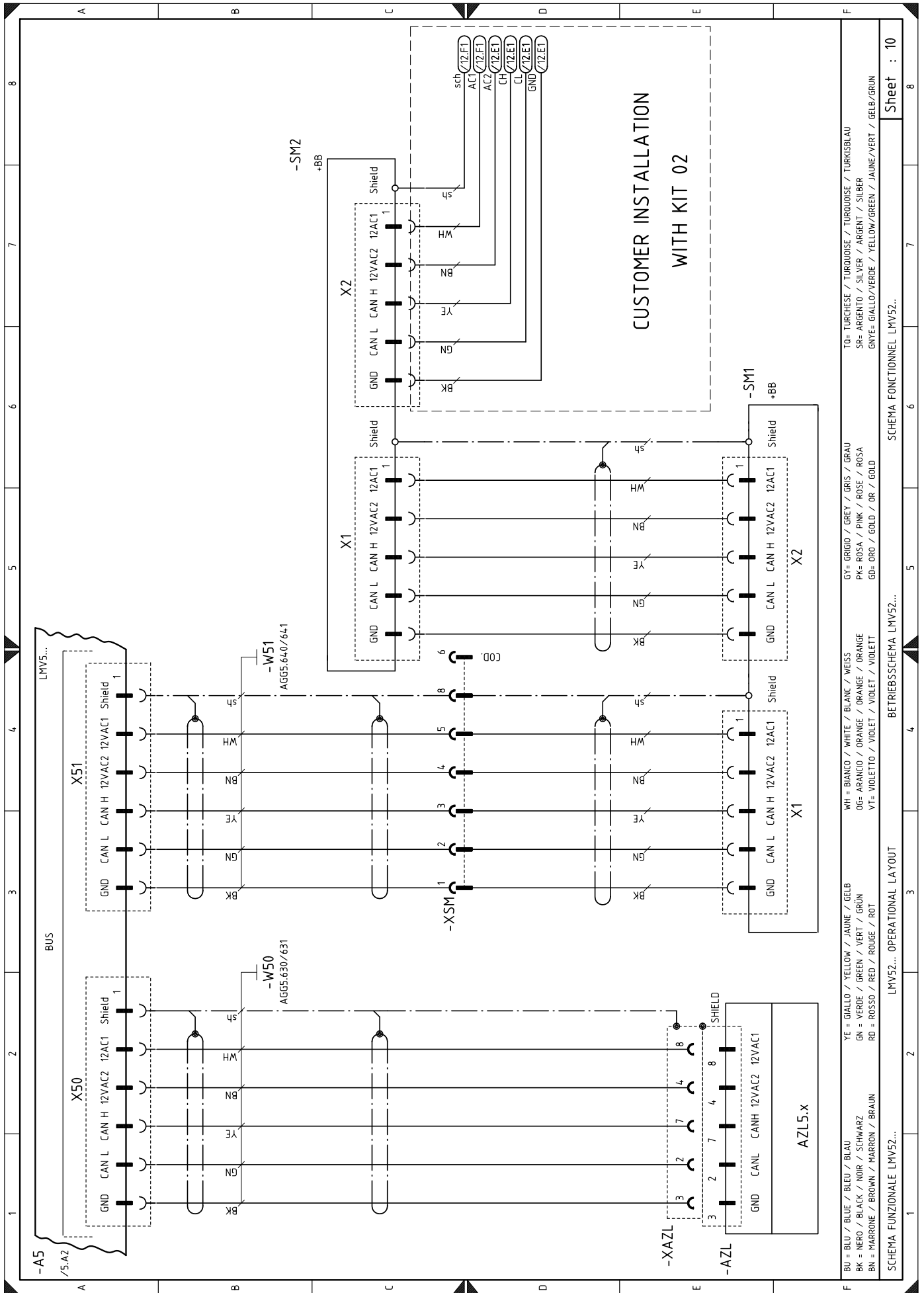

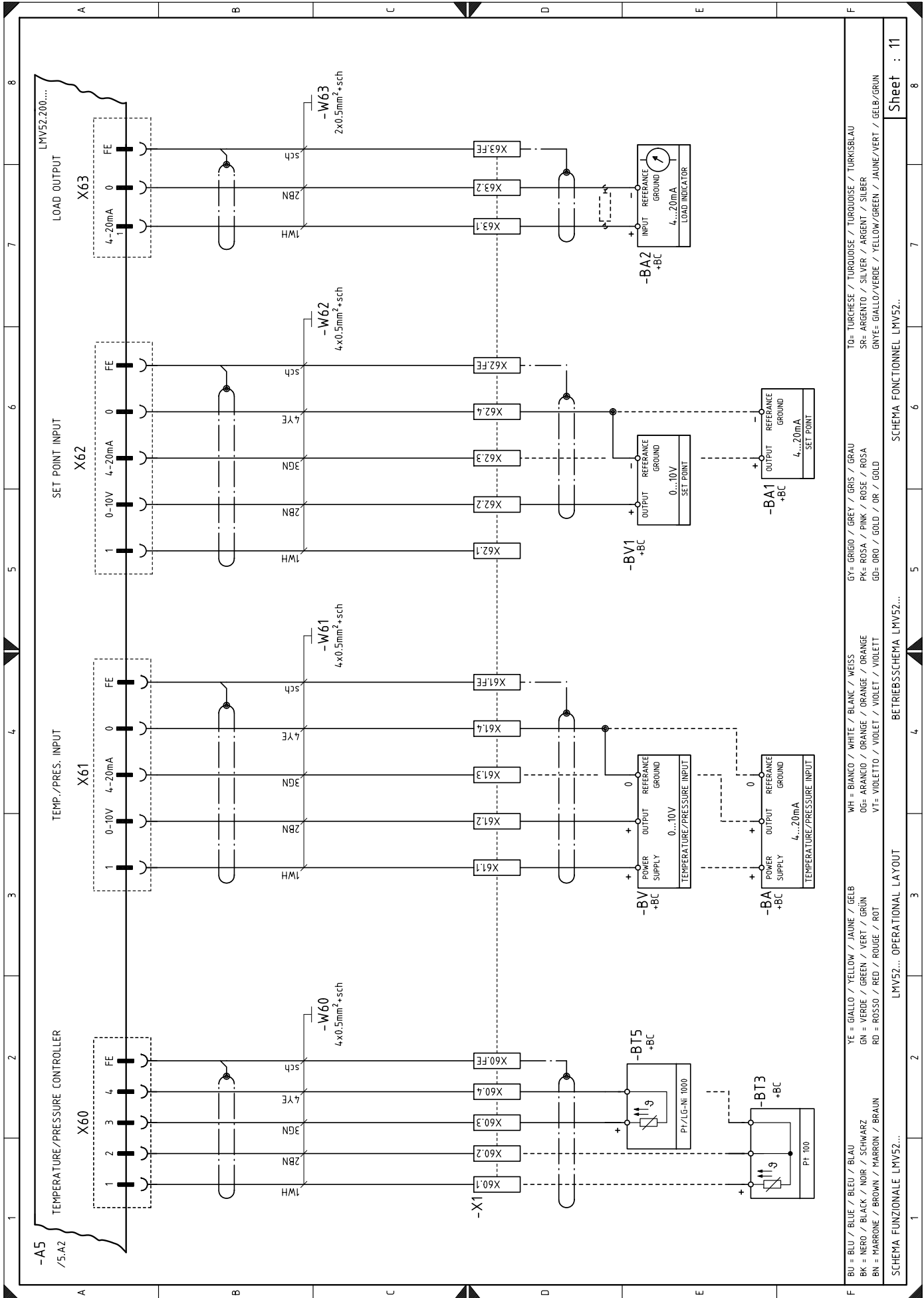



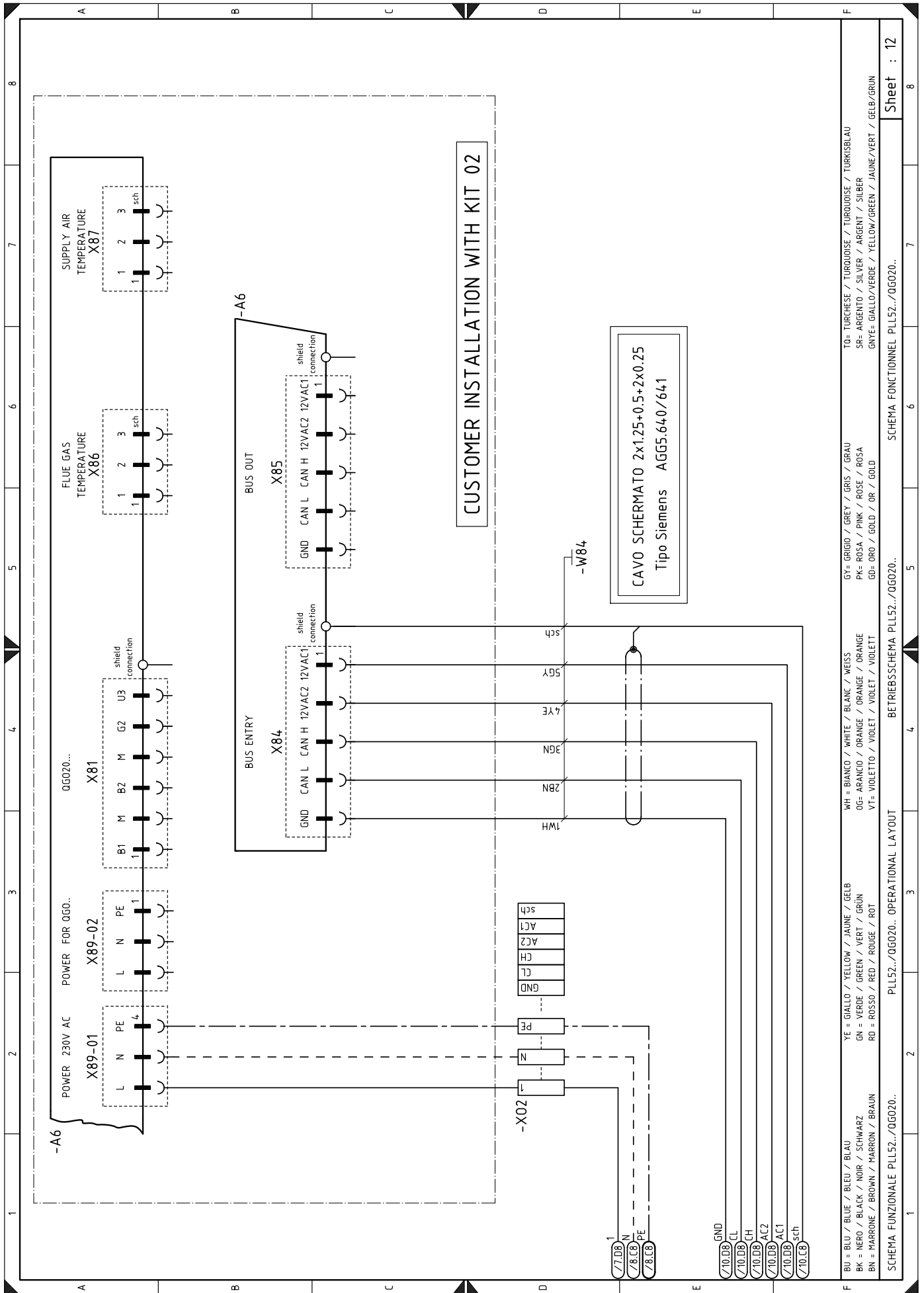

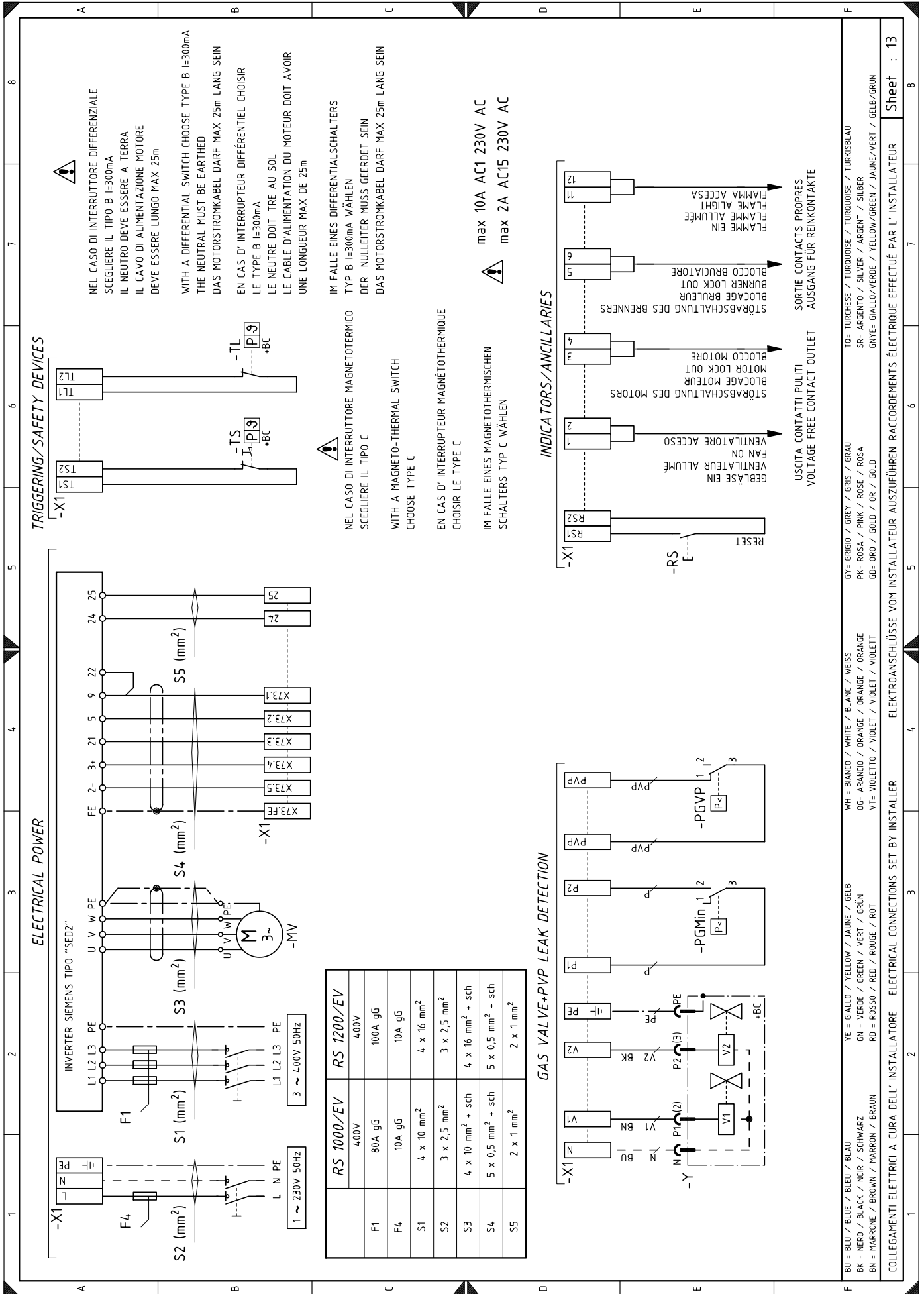

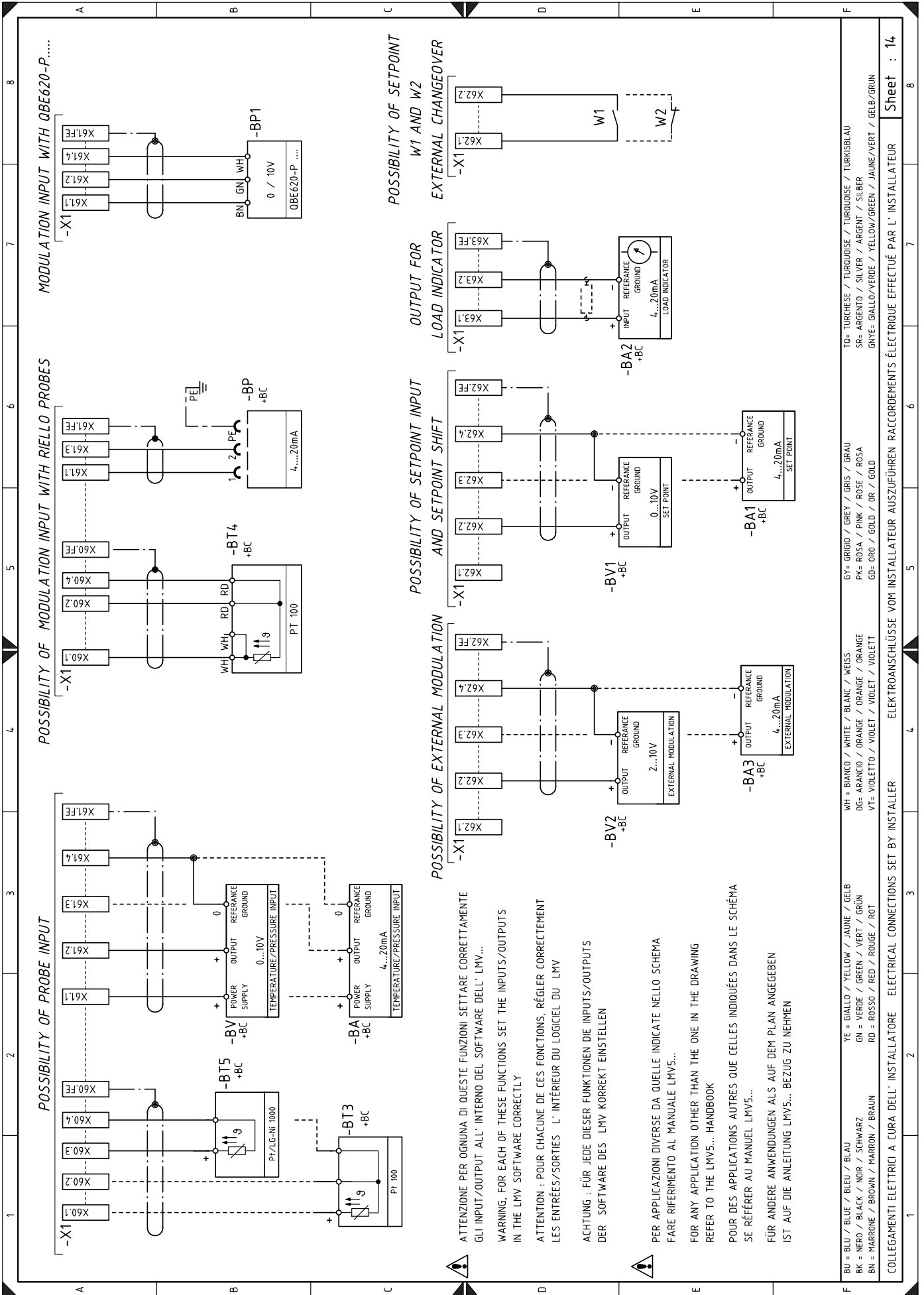

BU = BLU / BLUE / BLEU / BLAU	YE = GIALLO / YELLOW / JAUNE / GELB	WH = BIANCO / WHITE / BLANK / WEISS	GY = GRIGIO / GREY / GRIS / GRAU	TO = TURCHESE / TURKHOISE / TURKISBLAU
BK = NERO / BLACK / NOIR / SCHWARZ	GN = VERDE / GREEN / VERT / GRÜN	OG = ARANCIO / ORANGE / ORANGE / ORANGE	PK = ROSA / PINK / ROSE / ROSA	SR = ARGENTO / SILVER / ARGENT / SILBER
BN = MARRONE / BROWN / MARRON / BRAUN	RD = ROSSO / RED / ROUGE / ROT	VT = VIOLETTA / VIOLET / VIOLET / VIOLETT	GO = ORO / GOLD / OR / GOLD	GNVE = GIALLO/VERDE / YELLOW/GREEN / JAUNE/VERT / GELB/GRÜN

COLLEGAMENTI ELETTRICI A CURA DELL' INSTALLATORE    ELETTRICAL CONNECTIONS SET BY INSTALLER    ELEKTROANSCHLÜSSE VOM INSTALLATEUR AUSZUFÜHREN RACCORDEMENTS ÉLECTRIQUE EFFECTUÉ PAR L' INSTALLATEUR

Sheet : 14

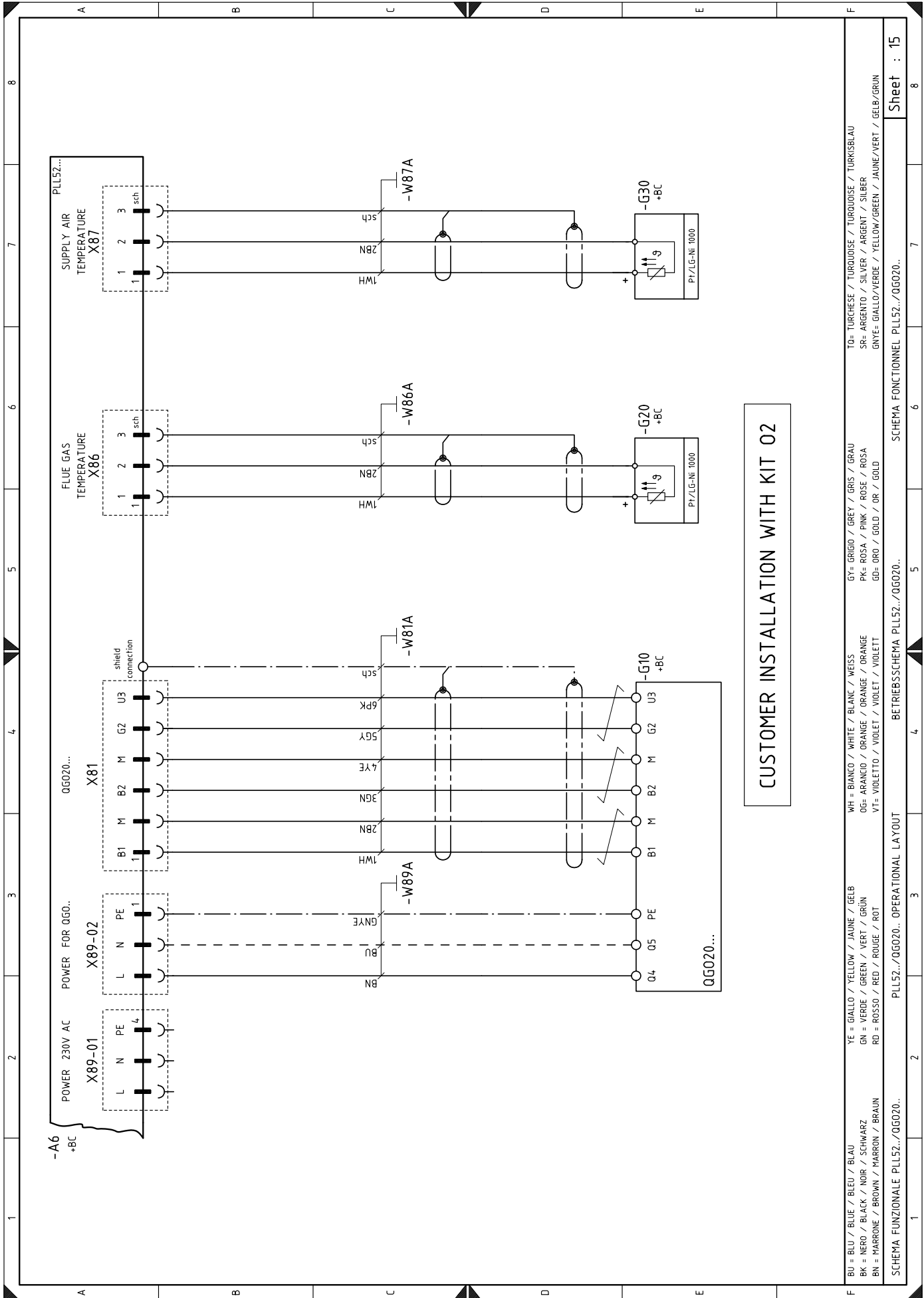

Sheet : 15

CUSTOMER INSTALLATION WITH KIT 02

BU = BLU / BLUE / BLEU / BLAU	GY = GRIGIO / GREY / GRIS / GRAU	TO = TURCHESE / TURQUOISE / TURKISBLAU
BK = NERO / BLACK / NOIR / SCHWARZ	OG = ARANCIO / ORANGE / ORANGE / ORANGE	SR = ARGENTO / SILVER / ARGENT / SILBER
BN = MARRONE / BROWN / MARRON / BRAUN	VT = VIOLETTA / VIOLET / VIOLET / VIOLETT	GNYE = GIALLO/VERDE / YELLOW/GREEN / JAUNE/VERT / GELB/GRÜN
YE = GIALLO / YELLOW / JAUNE / GELB	WH = BIANCO / WHITE / BLANC / WEISS	
GN = VERDE / GREEN / VERT / GRÜN	OG = ARANCIO / ORANGE / ORANGE / ORANGE	
RD = ROSSO / RED / ROUGE / ROT	VT = VIOLETTA / VIOLET / VIOLET / VIOLETT	
PLL52.../QG020... OPERATIONAL LAYOUT	BETRIEBSSCHEMA PLL52.../QG020...	SCHEMA FONCTIONNEL PLL52.../QG020...

**Wiring layout key**

A5	Control box	T1	Control box transformer
A6	O <sub>2</sub> module	XAZL	AZL display connector
AZL	Display for control box	XAUX	Auxiliary terminal board
BA	Probe with output under current	XPGM	Maximum gas pressure switch connector
BA1	Device with output under current, for modifying remote set-point	XS	Ionisation probe connector
BA2	Load indicator with input under current	XSM	Servomotor connector
BA3	Device with current output for remote modulation	X1	Main terminal supply board
BP	Pressure probe	X02	Kit O <sub>2</sub> terminal strip
BP1	Pressure probe	X70	Rpm sensor terminal board
BT3	Probe Pt100, 3 wires	Y	Gas adjustment valve + gas safety valve
BT4	Probe Pt100, 3 wires		
BT5	PT 1000 probe, 2 wires		
BV	Output probe in voltage		
BV1	Output device in voltage to modify remote set-point		
BV2	Device with voltage current output for remote modulation		
F1	Inverter power supply fuses		
F2	Line fuses		
F3	Auxiliary fuse		
F4	Line fuses		
GF	Inverter		
G2	Rpm sensor		
G10	Oxygen sensor		
G20	Fuel temperature probe		
G30	Air temperature probe		
H1	Light signalling burner on		
H2	Fan motor lockout warning lamp		
H3	Heat request lighting signal		
H4	Burner working lighting signal		
ION	Ionisation probe		
K1	Clean contacts output relay with fan motor working		
K2	Clean contacts output relay motor lockout		
K3	Clean contacts output relay for burner lockout		
K6	Clean contacts output relay burner switched on		
MV	Fan motor		
PA	Air pressure switch		
PE	Burner earth		
PGMax	Maximum gas pressure switch		
PGMin	Minimum gas pressure switch		
PGVP	Gas pressure switch for valve leak detection control device		
Q1	Inverter power supply disconnect switch		
Q2	Line disconnect switch		
RS	Remote burner reset button		
S1	Emergency stop button		
S2	0 / AUTO selector		
SH3	Burner reset button and lock-out signal		
SM1	Air servomotor		
SM2	Fuel servomotor		
TA	Ignition transformer		
TL	Limit thermostat/pressure switch		
TS	Safety thermostat/pressure switch		

---

**RIELLO**

RIELLO S.p.A.  
I-37045 Legnago (VR)  
Tel: +39.0442.630111  
[http:// www.riello.it](http://www.riello.it)  
[http:// www.riello.com](http://www.riello.com)