

## RLS 500÷1200/M MX SERIES

RLS/M burners are characterised by a modular monoblock structure that means all necessary components can be combined in a single unit thus making installation easier, faster and, above all, more flexible.

The series covers a firing range from 1120 to 11500 kW, and it has been designed for use in hot water boilers, overheated water boilers as well as steam boilers.

Operation can be "two stage progressive" or alternatively "modulating", for both fuels, light oil and gas, with the installation of a PID logic regulator .

The mechanical cam device of regulation allows to catch up a high modulation ratio on all firing rates range. The burners can, therefore, supply with precision the demanded power, guaranteeing a high efficiency system level and the stability setting, obtaining fuel consumption and operating costs reduction.

The combustion head guarantees reduced polluting emissions (NOx < 80 mg/kWh on gas operation). An exclusive design guarantees low sound emissions, low electrical consumption, easy use and maintenance.



RLS 500/M MX	1120/2500 ÷ 5050 kW
RLS 650/M MX	1430/3000 ÷ 6550 kW
RLS 800/M MX	1750/3500 ÷ 8000 kW
RLS 1000/M MX	1200/3750 ÷ 10600 kW
RLS 1200/M MX	1500/5500 ÷ 11500 kW

# Low NOx Modulating Dual Fuel Burners

## RLS 500÷1200/M MX SERIES

### FIRING RATES

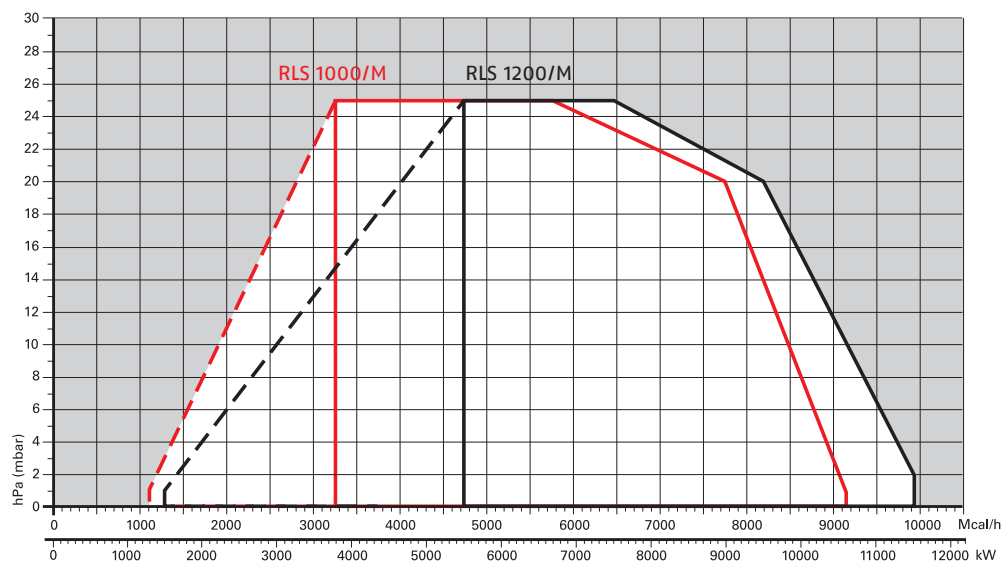
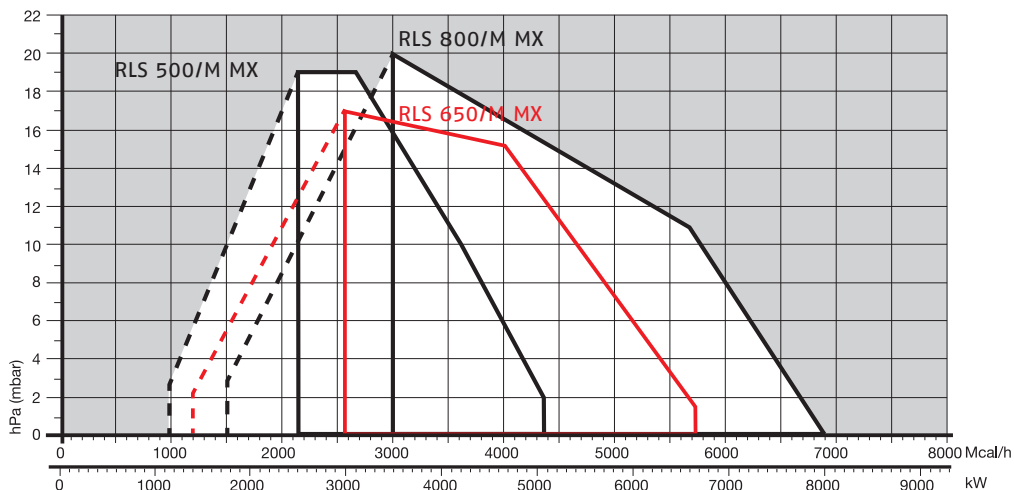

## Overall dimensions (mm)

### BURNER

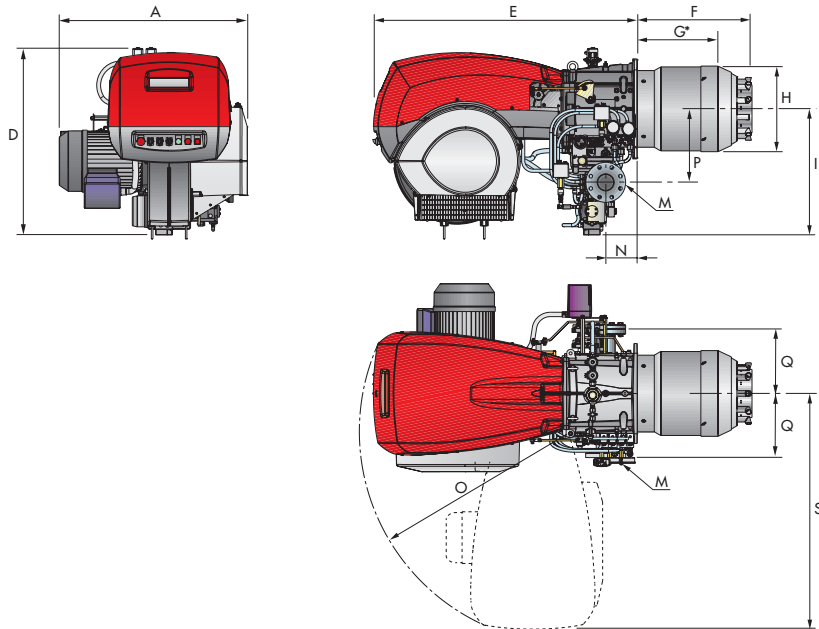

MODEL	A	D	E	F	G*	H	I	M	N	O	P	Q	S
▶ RLS 500/M MX	900	890	1325	544	390	370	605	DN80	164	1055	342	320	1175
▶ RLS 650/M MX	880	950	1325	562	360	410	630	DN80	164	1055	427	320	1190
▶ RLS 800/M MX	940	937	1325	558	382	428	630	DN80	164	1055	427	320	1190

\* Maximum depth of the boiler door including the depth of the burner flange insulating gasket.

### BURNER - BOILER MOUNTING FLANGE

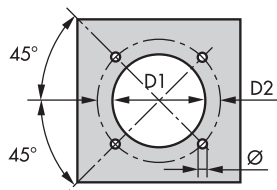

MODEL	D1	D2	Ø
▶ RLS 500/M MX	390	452	M18
▶ RLS 650/M MX	440	495	M18
▶ RLS 800/M MX	440	495	M18

### PACKAGING

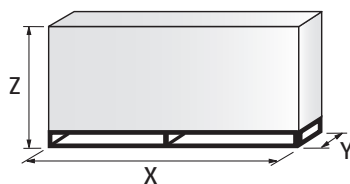

MODEL	X	Y	Z	kg
▶ RLS 500/M MX	1960	970	1100	280
▶ RLS 650/M MX	2190	1110	1450	320
▶ RLS 800/M MX	2190	1110	1450	320

# Low NOx Modulating Dual Fuel Burners

## RLS 500÷1200/M MX SERIES

### Overall dimensions (mm)

#### BURNER

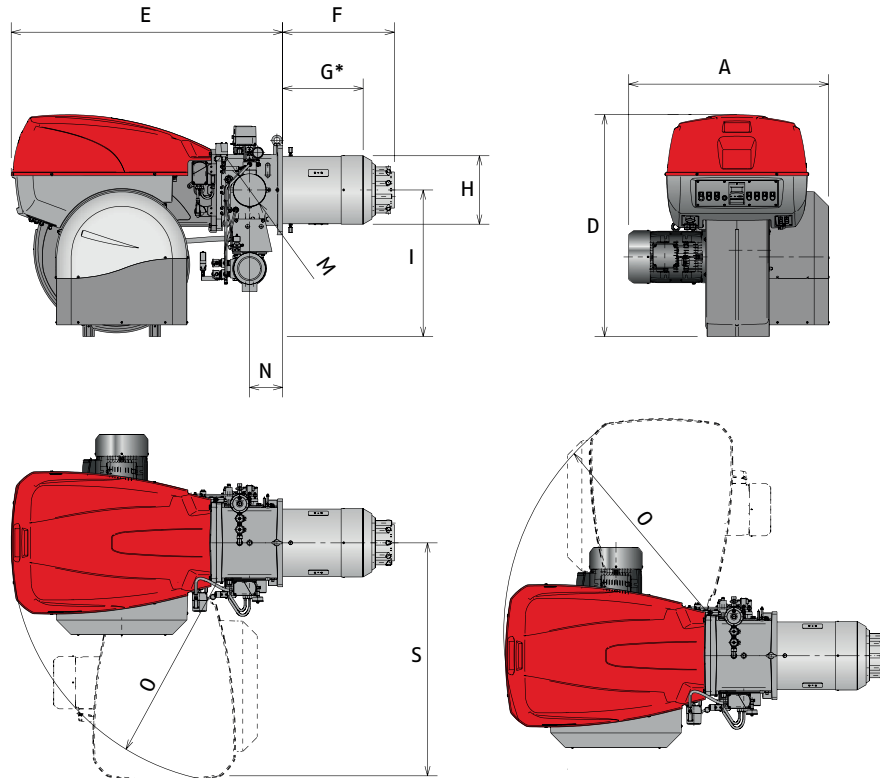

#### BURNER - BOILER MOUNTING FLANGE

MODEL	A	D	E	F	G*	H	I	M	N	O	S
► RLS 1000/M MX	1206	1338	1637	674	484	413	885	DN80	200	1350	1425
► RLS 1200/M MX	1250	1338	1637	658	465	456	885	DN80	200	1350	1425

\* Maximum depth of the boiler door including the depth of the burner flange insulating gasket.

#### BURNER - BOILER MOUNTING FLANGE

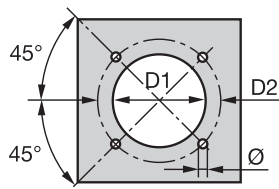

MODEL	D1	D2	Ø
► RLS 1000/M MX	460	608	M20
► RLS 1200/M MX	500	608	M20

#### PACKAGING

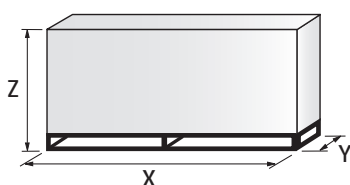

MODEL	X	Y	Z	kg
► RLS 1000/M MX	2400	1400	1595	550
► RLS 1200/M MX	2400	1400	1595	600

## RLS 500÷1200/M MX SERIES

# Specification

## DESIGNATION OF SERIES

Series: R	
Fuel:	S Natural Gas
	L Light oil
	LS Light oil/Natural Gas
	N Heavy oil
Size	
Setting:	/1 Single stage
	/B Two stage
	/M Modulating - Mechanical cam
	/P Proportioning air/gas valve
	/E Electronic cam
	/EV Electronic cam predisposed for variable speed (with inverter)
Emission:	C11 or ... Class 1 EN267 - EN676
	C22 or MZ Class 2 EN267 - EN676
	C33 or BLU Class 3 EN267 - EN676
	C23 or MX Class 2 EN267 - Class 3 EN676
	C13 Class 1 EN267 - Class 3 EN676
Head length:	TC standard head
	TL extended head
Flame control system:	FS1 Standard (1 stop every 24 h)
	FS2 Continuous working (1 stop every 72 h)
Electrical supply to the system:	
	1/230/50 1/230V/50Hz
	3/230/50 3/230V/50Hz
	3/400/50 3N/400V/50Hz
	3/230-400/50 3/230V/50Hz - 3N/400V/50Hz
	3/220/60 3/220V/60Hz
	3/380/60 3N/380V/60Hz
	3/220-380/60 3/220/60Hz - 3N/380V/60Hz
Auxiliary voltage:	230/50-60 230V/50-60Hz
	110/50-60 110V/50-60Hz

R	LS	1200	/M	MX	TC	FS1	3/400/50	230/50-60
BASIC DESIGNATION					EXTENDED DESIGNATION			

# Low NOx Modulating Dual Fuel Burners

## RLS 500÷1200/M MX SERIES

### Specification

#### STATE OF SUPPLY

Monoblock forced draught gas burner with modulating operation, fully automatic, made up of:

- High performance fan
- Air suction circuit lined with sound-proofing material
- Air damper for air setting controlled by a high precision servomotor
- Air pressure switch
- Fan starting motor at 2800 rpm, three-phase, 400V, 50Hz
- Low emission combustion head, that can be set on the basis of required output, fitted with:
  - stainless steel end cone, resistant to corrosion and high temperatures
  - ignition electrodes
  - ignition by gas pilot with gas train for RLS 650 - 800 - 1000 - 1200 models
  - flame stability disk
- Mechanical cam with gas and oil modulator
- Maximum gas pressure switch, with pressure test point, to stop the burner in the case of over pressure on the fuel supply line
- Flame control panel for controlling the system safety - Infrared flame detector
- Star/delta starter for the fan motor - Main electrical supply terminal board
- Burner on/off switch
- Auxiliary voltage led signal
- Burner working led signal
- Contacts motor and thermal relay with release button
- Motor internal thermal protection
- Motor failure led signal
- Burner failure led signal and lighted release button
- Emergency button
- Coded connection plugs-sockets
- Burner opening hinge
- Lifting rings
- IP 54 electric protection level
- Light oil gears pump for high pressure fuel supply
- Dedicated pump starting motor
- Valve unit with double oil safety valve on the output circuit and double safety valve on the return circuit
- Maximum an minimum oil pressure switches
- Oil pressure gauges on supply and return oil lines
- Oil/Gas selector
- Flame inspection window.
- The gas train can only enter from the left side of the burner (fan motor side)
- The RLS 1000-1200/M dual fuel burners are equipped with as spray lance for light oil, activated by compressed air.

#### Standard equipment:

- 1 flange gasket
- 4 screws for fixing the flange
- 1 thermal screen
- 4 screws for fixing the burner flange to the boiler
- 2 flexible pipes for connection to the oil supply network
- 2 nipples for connection to the pump with gaskets
- Seal control pressure switch (for installation on gas train)
- Instruction handbook for installation, use and maintenance
- Spare parts catalogue.

## RLS 500÷1200/M MX SERIES

### Available models

#### Burners

CODE	MODEL	HEAT OUTPUT			TOTAL ELECTRICAL POWER (kW)	CERTIFICATION
		(kW)	LIGHT OIL (kg/h)	NATURAL GAS (Nm <sup>3</sup> /h)		
3899612	RLS 500/M MX TC FS1 3/400/50 230/50-60	1120/2500-5050	95/211-426	112/250-505	13,9 (oil) 15,7 (gas)	CE-0085CL0207
20026139	RLS 650/M MX TC FS1 3/400/50 230/50-60	1430/3000-6550	121/253÷552	143/300÷655	22,4 (oil) 20,6 (gas)	CE-0085CL0207
3911112	RLS 800/M MX TC FS1 3/400/50 230/50-60	1750/3500-8000	148/295-675	175/350-800	25,8 (oil) 24 (gas)	CE-0085CL0422
20057525	RLS 1000/M MX TC FS1 3/400/50 230/50-60	1200/3750-10600	110/320-793	130/380-940	27 (oil) 24 (gas)	CE-0085CN0119
20053012	RLS 1200/M MX TC FS1 3/400/50 230/50-60	1500/5500-11500	126/464-970	150/550-1150	32 (oil) 27,2 (gas)	CE-0085CN0120

Net calorific value light oil: 11,8 kWh/kg; 10.200 kcal/kg - Viscosity at 20°C: 4-6 mm<sup>2</sup>/s (cSt).

Net calorific value G20 gas: 10 kWh/Nm<sup>3</sup>; 8.600 kcal/Nm<sup>3</sup> - Density: 0,71 kg/Nm<sup>3</sup>.

The burners of RLS/M MX series are in according to 2009/142 EC - 2004/108 - 2006/95 - EC Directive and EN 267 - 676 Norm.

#### Gas Trains

CODE	GAS TRAIN MODEL	Ø	C.T.	VPS CODE	ADAPTER CODE				
					RLS 500	RLS 650	RLS 800	RLS 1000	RLS 1200
3970221*	MBC 1200/1 - RSM 60	Rp 2"	-	3010367	3000826 + 20042324				
3970225**	MBC 1200/1 CT RSM 60	Rp 2"	◆	-					
3970222*	MBC 1900/1 - FSM 40	DN 65	-	3010367	3010221 - 3010369				
3970226**	MBC 1900/1 CT FSM 40	DN 65	◆	-					
3970223*	MBC 3100/1 - FSM 40	DN 80	-	3010367	3010222 (i)				
3970227**	MBC 3100/1 CT FSM 40	DN 80	◆	-					
3970224*	MBC 5000/1 - FSM 80	DN 100	-	3010367	3010223 - 3010370				
3970228**	MBC 5000/1 CT FSM 80	DN 100	◆	-					
3970146*	CB 520/1 - RSM 30	Rp 2"	-	3010367	3000826 +	●	●	●	●
3970160**	CB 520/1 CT RSM 30	Rp 2"	◆	-	20042324	●	●	●	●
20044659*	CB 525/1 - RSM 30	Rp 2"	-	3010367	3000826 + 20042324				
20044660**	CB 525/1 CT RSM 30	Rp 2"	◆	-					
3970147*	CB 5065/1 - FSM 30	DN 65	-	3010367	3010221 - 3010369				
3970161**	CB 5065/1 CT FSM 30	DN 65	◆	-					
3970148*	CB 5080/1 - FSM 30	DN 80	-	3010367	3010222 (i)				
3970162**	CB 5080/1 CT FSM 30	DN 80	◆	-					
3970149*	CB 50100/1 - FSM 30	DN 100	-	3010367	3010223 - 3010370				
3970163**	CB 50100/1 CT FSM 30	DN 100	◆	-					
20015871*	CB 50125/1 - FSM 30	DN 125	-	3010367	3010224				
3970196**	CB 50125/1 CT FSM 30	DN 125	◆	-					

Please see designation of Gas Train Series in the page before the Catalogue index.

\* 230V/50Hz -220V/60Hz electrical supply.

\*\* 230V/50Hz electrical supply.

The valve seal control device is compulsory (conforming to EN 676) on gas trains to burners with a maximum output over 1200 kW.

To select the gas train please refer to the technical data leaflet and/or instruction manual.

C.T. Gas valve leak detection control device:

- gas train not equipped with leak detection control device; this device can be ordered separately - see VPS column - and installed later.

◆ gas train equipped with leak detection control device.

VPS Valve leak detection control device. Supplied separately from the gas train (please see Gas train accessories paragraph for both 50 Hz and 60 Hz codes).

(i) To use it is necessary to space out the gas train from the burner.

● Not available.

# Low NOx Modulating Dual Fuel Burners

## RLS 500÷1200/M MX SERIES

### Burner accessories

#### Nozzles

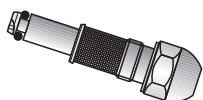

Return nozzles without needle are used on RLS/M MX burners. The nozzle must be ordered as accessory. The following table shows the features and codes on the basis of the maximum required fuel output.

BURNER	NOZZLE TYPE	RATED DELIVERY (kg/h)	NOZZLE CODE
▶ RLS 500/M MX	N2	350	3045495
▶ RLS 500/M MX	N2	400	3045499
▶ RLS 500/M MX	N2	450	3045501
▶ RLS 500/M MX	N2	500	3045503
▶ RLS 650/M MX	N2	350	3045495
▶ RLS 650/M MX	N2	450	3045501
▶ RLS 650/M MX	N2	550	3045505
▶ RLS 650/M MX	N2	600	3045507
▶ RLS 800/M MX	B5 SA 45°	375	3009332
▶ RLS 800/M MX	B5 SA 45°	550	3009346
▶ RLS 800/M MX	B5 SA 45°	650	3009352
▶ RLS 800/M MX	B5 SA 45°	750	3009356
▶ RLS 1000/M MX	B5 AA 60°	350	20047954
▶ RLS 1000/M MX	B5 AA 60°	600	20047978
▶ RLS 1000/M MX	B5 AA 60°	750	20047985
▶ RLS 1000/M MX	B5 AA 60°	900	20047994
▶ RLS 1200/M MX	CT5 60°	700	20006479
▶ RLS 1200/M MX	CT5 60°	700	20006479
▶ RLS 1200/M MX	CT5 60°	900	20006482
▶ RLS 1200/M MX	CT5 60°	1100	20006484

For more information please contact Riello Burners Commercial and Technical Department, our Application Engineers will be pleased to help you.

#### Accessories for modulating operation

##### POWER CONTROLLER



To obtain modulating operation, the RLS/M MX series of burners requires a regulator.

BURNER	REGULATOR TYPE	REGULATOR CODE
▶ All models	RWF 40 Basic version with 3 position output	3010356
▶ All models	RWF 40 High version with additional modulating output and RS 485 Interface	3010357

##### PROBE



The relative temperature or pressure probes fitted to the regulator, must be chosen on the basis of the application.

BURNER	PROBE TYPE	RANGE (°C) (bar)	PROBE CODE
▶ All models	Temperature PT 100	-100 ÷ 500°C	3010110
▶ All models	Pressure 4 ÷ 20 mA	0 ÷ 2,5 bar	3010213
▶ All models	Pressure 4 ÷ 20 mA	0 ÷ 16 bar	3010214
▶ All models	Pressure 4 ÷ 20 mA	0 ÷ 25 bar	3090873



## Burner accessories

### ANALOG CONTROL SIGNAL CONVERTER



BURNER	TYPE (INPUT SIGNAL)	CODE
► All models	0/2 - 10 V (impedance 200 K $\Omega$ ) 0/4 - 20 mA (impedance 250 $\Omega$ )	3010390

### POTENTIOMETER



BURNER	KIT CODE
► RLS 500-650-800/M	3010402
► RLS 1000-1200/M	in progress

It is necessary for analogic control signal converter operation.

## Fuel remote selection kit



BURNER	KIT CODE
► RLS 500-650-800/M	3010372

## Sound proofing box

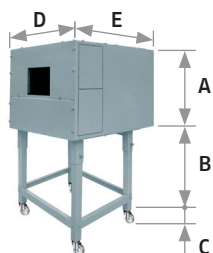

If noise emission needs reducing even further, sound-proofing boxes are available. In case of generator heights, where a lower dimension "B" is required, ask for the Box Support Kit code 20065135. The useful dimensions are 40 mm less than the total dimensions indicated in the table (A, D, E). Not suitable for outdoor use.

BURNER	BOX TYPE	A (mm)	B (mm) min-max	C (mm)	D (mm)	E (mm)	[dB(A)] (*)	BOX CODE
► RLS 500-650-800/M	C7	1255	160 - 980	110	1140	1345	10	3010376
► RLS 1000-1200/M	C8	1425	285 - 1000	110	1500	1800	10	3010401

(\*) Average noise reduction according to EN 15036-1 standard

## Spacer kit

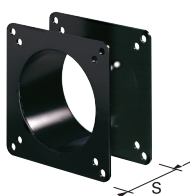

If burner head penetration into the combustion chamber needs reducing, varying thickness spacers are available, as given in the following table:

BURNER	SPACER THICKNESS S (mm)	KIT CODE
► RLS 500-650-800/M	180	20008903

# Low NOx Modulating Dual Fuel Burners

## RLS 500÷1200/M MX SERIES

### Burner accessories

#### Continuous ventilation kit



If the burner requires continuous ventilation in the stages without flame, a special kit is available as given in the following table:

BURNER	KIT CODE
► RLS 1000-1200/M	20086519

### Gas train accessories

#### Adapters

In certain cases, an adapter must be fitted between the gas train and the burner, when the diameter of the gas train is different from the set diameter of the burner. Below are given the available adapters; please see on the Gas Train list the correct adapter codes to select.

ADAPTER	DIMENSIONS					ADAPTER CODE
	Ø1 DN	Ø0 DN	A mm	B mm	C mm	
	65	80	400	-	-	3010221
	80	80	400	-	-	3010222
	100	80	400	-	-	3010223
	125	80	320	-	-	3010224
	65	80	10	-	-	3010369
	100	80	50	-	-	3010370
	-	-	35	-	-	3000843
	-	-	300	-	-	3000826
	-	-	65	-	-	20042324

## RLS 500÷1200/M MX SERIES

### Gas train accessories

#### Stabiliser spring



To vary the pressure range of the gas train stabilisers, accessory springs are available. The following table shows these accessories with their application range. Please refer to the technical manual for the correct choice of spring.

GAS TRAIN	SPRING COLOUR	SPRING PRESSURE RANGE mbar	SPRING CODE
▶ MBC 1900/1 - 3100/1 MBC 5000/1	White	4 - 20	3010381
	Red	20 - 40	3010382
	Black	40 - 80	3010383
	Green	80 - 150	3010384
▶ CB 5065/1-5080/1	Red	25 - 55	3010133
	Black	60 - 110	3010135
	Pink	100 - 150	3090456
	Grey	140 - 200	3090992
▶ CB 50100/1	Red	25 - 55	3010134
	Black	60 - 110	3010136
	Pink	100 - 150	3090489
	Grey	140 - 200	3092174
▶ CB 50125/1	Red	25 - 55	3010315
	Yellow	30 - 70	3010316
	Black	60 - 110	3010317
	Pink	100 - 150	3010318

#### Seal control kit



To test the valve seals on the gas train, a special "seal control kit" is available. The valve seal control device is compulsory (EN 676) on gas trains to burners with a maximum output over 1200 kW. The seal control is type VPS 504.

GAS TRAIN	KIT CODE for 50 Hz operation	KIT CODE for 60 Hz operation
▶ MBC/1 type	3010367	20029057
▶ CB/1 type	3010367	20029057