

- I** Bruciatori policombustibile gasolio/gas
- GB** Dual fuel gas oil/gas burners
- F** Brûleurs mixtes fioul/gaz
- D** Mehrstoffbrenner Heizöl/Gas
- E** Quemadores policombustible gasòleo/gas

Funzionamento bistadio progressivo o modulante
Two stage progressive or modulating operation
Fonctionnement à 2 allures progressif ou modulant
Zweistufig gleitender oder modulierender Betrieb
Funcionamiento a dos llamas progresivas o modulante

CODICE - CODE CÓDIGO	MODELLO - MODEL - MODELE MODELL - MODELO	TIPO - TYPE - TYP
20034254	RLS 1000/M C13	1311T
20034255	RLS 1200/M C13	1312T

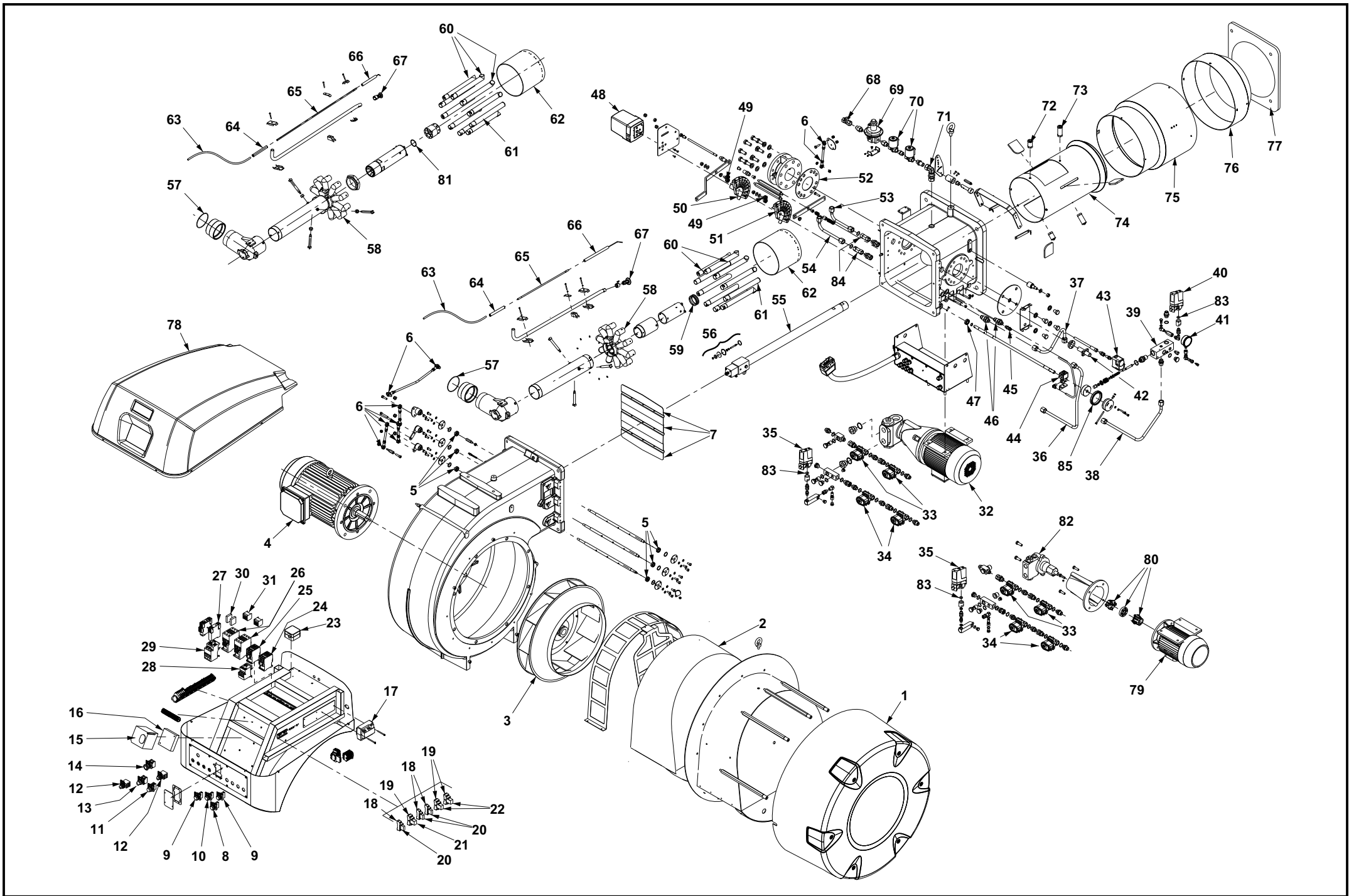

N.	COD.	20034254	20034255	DESCRIZIONE	DESCRIPTION	DESCRIPTION	BESCHREIBUNG	DENOMINACION	MATRICOLA BRUCIATORE BURNER SERIAL NUMBER MATRICULE BRULEUR BRENNER KENN-NUMMER MATRICULA QUEMADORES	*
		•	•							
1	20032624	•	•	COFANO	COVER	CAPOT	VERKLEIDUNG	ENVOLVENTE		B
2	20032626	•	•	FONOASSORBENTE	SOUND DAMPING	INSONORISANT	GERÄUSCHDÄMMUNG	AISLAMIENTO ACUSTICO		
3	20039344	•		GIRANTE	FAN	TURBINE	GEBLÄSERAD	TURBINA		C
3	20039521	•		GIRANTE	FAN	TURBINE	GEBLÄSERAD	TURBINA		C
4	20039345	•		MOTORE VENTILATORE	FAN MOTOR	MOTEUR VENTILATEUR	GEBLÄSEMOTOR	MOTOR VENTILADOR		C
4	3013963	•		MOTORE VENTILATORE	FAN MOTOR	MOTEUR VENTILATEUR	GEBLÄSEMOTOR	MOTOR VENTILADOR		C
5	3012795	•	•	CUSCINETTO	BEARING	ROULEMENT	LAGER	COJINETE		C
6	3012669	•	•	SNODO SFERICO	PIN JOINT	CHAPE A ROTULE	KUGELGELENK	ARTICOLACION ESFERICA		C
7	20032625	•	•	GRUPPO SERRANDA ARIA	AIR DAMPER ASSEMBLY	GROUPE VOLET AIR	LUFTREGULIERUNG	CONJUNTO REGISTRO AIRE		
8	20027018	•	•	INDICATORE LUMINOSO ROSSO	RED SIGNAL LIGH	SIGNAL LUMINEUX ROUGE	ROTE LEUCHTANZEIGE	INDICADOR LUMINOSO ROJO		A
9	20036017	•	•	INDICATORE LUMINOSO VERDE	GREEN SIGNAL LIGHT	SIGNAL LUMINEUX VER	GRÜNE LEUCHTANZEIGE	INDICADOR LUMINOSO VERDE		A
10	20036019	•	•	INDICATORE LUMINOSO BIANCO	WHITE SIGNAL LIGHT	SIGNAL LUMINEUX BLANC	WEISS LEUCHTANZEIGE	INDICADOR LUMINOSO BLANCO		A
11	3013354	•	•	PULSANTE LUMINOSO	SIGNAL BUTTON	BOUTON DE SIGNALISATION	ANZEIGETASTE	PULSADOR LUMINOSO		
12	3013474	•	•	SELETTORE	SWITCH	SÉLECTEUR	SCHALTER	SELECTIVO		C
13	3013335	•	•	SELETTORE	SWITCH	SÉLECTEUR	SCHALTER	SELECTIVO		C
14	3013333	•	•	PULSANTE DI EMERGENZA	SAFETY BUTTON	BOUTON DE SÉCURITÉ	SICHEREITSTASTE	PULSADOR DE LA EMERGENCIA		
15	3006090	•	•	APPARECCHIATURA	CONTROL BOX	BOITE DE CONTROLE	STEUERGERÄT	CAJA DE CONTROL		B
16	3013010	•	•	ZOCCOLO	CONTROL BOX BASE	SOCLE	SOCKEL	ZOCALO		
17	3003847	•	•	TRASFORMATORE	TRANSFORMER	TRANSFORMATEUR	TRANSFORMER	TRANSFORMADOR		
18	3012841	•	•	ZOCCOLO	CONTROL BOX BASE	SOCLE	SOCKEL	ZOCALO		
19	3003935	•	•	ZOCCOLO	CONTROL BOX BASE	SOCLE	SOCKEL	ZOCALO		
20	3012842	•	•	RELÈ	RELAY	RELAIS	RELAIS	RELÉ		C
21	3012368	•	•	RELÈ	RELAY	RELAIS	RELAIS	RELÉ		C
22	20005520	•	•	RELÈ	RELAY	RELAIS	RELAIS	RELÉ		C
23	3013449	•	•	PRESSOSTATO ARIA	AIR PRESSURE SWITCH	PRESSOSTAT AIR	LUFTDRUCKWÄCHTER	PRESÓSTATO AIRE		A
24	3013569	•	•	CONTATTORE	CONTACTOR	CONTACTEUR	SCHÜTZ	CONTADOR		C
25	3013571	•	•	CONTATTORE	CONTACTOR	CONTACTEUR	SCHÜTZ	CONTADOR		C
26	20032710	•	•	CONTATTORE	CONTACTOR	CONTACTEUR	SCHÜTZ	CONTADOR		C
27	3013573	•	•	TEMPORIZZATORE	TIMER	TEMPORISATEUR	ZEITRELAIS	TEMPORIZADOR		B
28	20027917	•	•	RELÈ TERMICO	OVERLOAD	RELAIS THERMIQUE	ÜBERSTROMAUSLÖSER	RELÈ TERMICO		C
29	20039354	•	•	RELÈ TERMICO	OVERLOAD	RELAIS THERMIQUE	ÜBERSTROMAUSLÖSER	RELÈ TERMICO		C
30	20013967	•	•	CONTATTO AUSILIARIO NO	AUXILIARY CONTACT NO	CONTACTES AUXILIARES NO	HILFSKONTAKT NO	CONTACTO AUXILIAR NO		C
31	20013969	•	•	CONTATTO AUSILIARIO NC	AUXILIARY CONTACT NC	CONTACTES AUXILIARES NC	HILFSKONTAKT NC	CONTACTO AUXILIAR NC		C
32	20034263	•		GRUPPO POMPA	PUMP ASSEMBLY	GROUPE POMPE	PUMPESYSTEM	CONJUNTO BOMBA		
33	20036036	•	•	VALVOLA DI SICUREZZA	SAFETY VALVE	SOUPAGE DE SÛRETÉ	SICHERHEITSVENTIL	VÁLVULA DE SEGURIDAD		

N.	COD.	20034254	20034255	DESCRIZIONE	DESCRIPTION	DESCRIPTION	BESCHREIBUNG	DENOMINACION	MATRICOLA BRUCIATORE BURNER SERIAL NUMBER MATRICULE BRULEUR BRENNER KENN-NUMMER MATRICULA QUEMADORES	*
		•	•							
34	3012659	•	•	VALVOLA DI SICUREZZA	SAFETY VALVE	SOUPAGE DE SÛRETÉ	SICHERHEITSVENTIL	VÁLVULA DE SEGURIDAD		
35	3014167	•	•	PRESSOSTATO OLIO	OIL PRESSURE SWITCH	PRESSOSTAT FIOUL	ÖLDRUCKWÄCHTER	PRESÓSTATO ACEITE		A
36	20039372	•		TUBO	TUBE	TUYAU	RÖHRCHEN	TUBO		
36	20039732	•		TUBO	TUBE	TUYAU	RÖHRCHEN	TUBO		
37	20040468	•	•	TUBO	TUBE	TUYAU	RÖHRCHEN	TUBO		
38	20040471	•	•	TUBO OLIO	OIL TUBE	TUYAU FIOUL	ÖLRÖHRCHEN	TUBO ACEITE		
38	20040494	•		TUBO OLIO	OIL TUBE	TUYAU FIOUL	ÖLRÖHRCHEN	TUBO ACEITE		
39	20040472	•	•	MODULATORE	MODULATOR	MODULATEUR	MODULATOR	MODULATOR		B
40	20042551	•	•	PRESSOSTATO OLIO	OIL PRESSURE SWITCH	PRESSOSTAT FIOUL	ÖLDRUCKWÄCHTER	PRESÓSTATO ACEITE		A
41	3012662	•	•	MANOMETRO	PRESSURE GAUGE	MANOMETRE	MANOMETER	MANOMETRO		
42	20005518	•	•	FOTOCELLULA UV	UV PHOTOCELL	PHOTOCELLULE UV	UV PHOTOZELLE	FOTOCÉLULA UV		A
43	3012197	•	•	PRESSOSTATO GAS	GAS PRESSURE SWITCH	PRESSOSTAT GAZ	GASDRUCKWÄCHTER	PRESOSTATO DE GAS		B
44	20037836	•	•	VALVOLA A 3 VIE	3 WAY VALVE	VANNE A 3 VOIES	DREIWEGEVENTIL	VÁLVULA DE 3 VÍAS		B
45	20039374	•	•	RACCORDO	CONNECTOR	MAMELON	NIPPEL	RACORD		C
46	20039375	•	•	RACCORDO	CONNECTOR	MAMELON	NIPPEL	RACORD		C
47	3013650	•	•	CUSCINETTO	BEARING	ROULEMENT	LAGER	COJINETE		C
48	3000871	•	•	SERVOMOTORE	SERVOMOTOR	SERVOMOTEUR	STELLANTRIEB	SERVOMOTOR		B
49	3013652	•	•	GRUPPO FLOTTANTE	FLOATING ASSEMBLY	GROUPE FLOTTANTE	SCHWIMMERSYSTEM	CONJUNTO FLOTANTE		
50	3013865	•	•	CAMMA	CAM	CAME	NOCKEN	EXCÉNTRICO		C
51	3012864	•	•	CAMMA	CAM	CAME	NOCKEN	EXCÉNTRICO		C
52	3013430	•	•	GUARNIZIONE	SEAL	JOINT	DICHTUNG	JUNTA		B
53	20040235	•	•	TUBO OLIO	OIL TUBE	TUYAU FIOUL	ÖLRÖHRCHEN	TUBO ACEITE		
54	20040234	•	•	TUBO OLIO	OIL TUBE	TUYAU FIOUL	ÖLRÖHRCHEN	TUBO ACEITE		
55	20039363	•		LANCIA	LANCE	LANCE	DÜSENTRAGROHR	LANZA		
55	20040307	•		LANCIA	LANCE	LANCE	DÜSENTRAGROHR	LANZA		
56	20039365	•	•	KIT O-RING LANCIA	LANCE O-RING KIT	KIT JOINT TORIQUE LANCE	DÜSENTRAGROHR O-RING KIT	KIT JUNTA TÓRICA LANZA		B
56	20032217	•		KIT O-RING LANCIA	LANCE O-RING KIT	KIT JOINT TORIQUE LANCE	DÜSENTRAGROHR O-RING KIT	KIT JUNTA TÓRICA LANZA		B
57	3012868	•	•	ANELLO OR	O-RING	JOINT TORIQUE	O-RING-DICHTUNG	JUNTA TÓRICA		B
58	3013105	•		DISTRIBUTORE	DISTRIBUTOR	DISTRIBUTEUR	GASKOPF	DISTRIBUIDOR		
58	20040340	•		DISTRIBUTORE	DISTRIBUTOR	DISTRIBUTEUR	GASKOPF	DISTRIBUIDOR		
59	20039356	•	•	RIDUZIONE	TRANSITION PIECE	PIÈCE DE RÉDUCTION	ÜBERGANGSSTÜCK	ADAPTADOR		
60	20029690	•	•	TUBO GAS	GAS TUBE	TUYAU GAZ	GASRÖHRCHEN	TUBO GAS		
61	20039358	•		TUBO GAS	GAS TUBE	TUYAU GAZ	GASRÖHRCHEN	TUBO GAS		
61	3013101	•		TUBO GAS	GAS TUBE	TUYAU GAZ	GASRÖHRCHEN	TUBO GAS		
62	20039357	•		PARZIALIZZATORE	SHUTTER	CLAPET	JALOUSIE	PARCIALIZADORA		
62	20040293	•		PARZIALIZZATORE	SHUTTER	CLAPET	JALOUSIE	PARCIALIZADORA		

N.	COD.	20034254	20034255	DESCRIZIONE	DESCRIPTION	DESCRIPTION	BESCHREIBUNG	DENOMINACION	MATRICOLA BRUCIATORE BURNER SERIAL NUMBER MATRICULE BRULEUR BRENNER KENN-NUMMER MATRICULA QUEMADORES	*
		•	•							
63	3003973	•	•	COLLEGAMENTO ELETTRODO	HIGH VOLTAGE LEAD	CABLE DE CONNEXION ELECTRODE	ELEKTRODEVERBINDUNG	CABLE CONEXIÓN ELECTRODO		A
64	20013160	•		ISOLATORE	INSULATOR	PORCELAINE D'ELECTRODE	ISOLATOR	AISLADOR		A
64	3012258	•		ISOLATORE	INSULATOR	PORCELAINE D'ELECTRODE	ISOLATOR	AISLADOR		A
65	3012995	•	•	COLLEGAMENTO ELETTRODO	HIGH VOLTAGE LEAD	CABLE DE CONNEXION ELECTRODE	ELEKTRODEVERBINDUNG	CABLE CONEXIÓN ELECTRODO		A
65	20021062	•		COLLEGAMENTO ELETTRODO	HIGH VOLTAGE LEAD	CABLE DE CONNEXION ELECTRODE	ELEKTRODEVERBINDUNG	CABLE CONEXIÓN ELECTRODO		A
66	20014630	•		ELETTRODO	ELECTRODE	ELECTRODE	ELEKTRODE	ELECTRODO		A
66	20011338	•		ELETTRODO	ELECTRODE	ELECTRODE	ELEKTRODE	ELECTRODO		A
67	20039355	•	•	DIFFUSORE PILOTA	PILOT DIFFUSER	DIFFUSEUR PILOTE	VERTEILER PILOT	DIFUSOR PILOTO		
68	3012852	•	•	RUBINETTO GAS	GAS COCK	ROBINET GAZ	GASHAHN	GRIFO GAS		
69	3012653	•	•	STABILIZZATORE	STABILIZER	STABILISATEUR	STABILISATOR	ESTABILIZADOR		
70	3012853	•	•	ELETTROVALVOLA	SOLENOID VALVE	ELECTROVANNE	MAGNETIVENTIL	ELECTROVÁLVULA		B
71	20014633	•	•	RACCORDO	CONNECTOR	MAMELON	NIPPEL	RACORD		C
72	20039366	•	•	SUPPORTO	SUPPORT	SUPPORT	HALTER	SOPORTE		A
73	20034046	•		SUPPORTO	SUPPORT	SUPPORT	HALTER	SOPORTE		A
74	3013098	•	•	OTTURATORE	SHUTTER	OBTURATEUR	SCHIEBER	OBTURADOR		C
75	3013390	•		CILINDRO	CYLINDER	CYLINDRE	ZYLINDER	CILINDRO		C
75	3013099	•		CILINDRO	CYLINDER	CYLINDRE	ZYLINDER	CILINDRO		C
76	3013391	•	•	IMBUTO FIAMMA	END CONE	EMBOUT GUEULARD	FLAMMENROHR	TUBO EXTREMO		B
76	3013100	•		IMBUTO FIAMMA	END CONE	EMBOUT GUEULARD	FLAMMENROHR	TUBO EXTREMO		B
77	3013392	•		SCHERMO	FLANGE GASKET	JOINT ISOLANT	FLANSCHDICHTUNG	JUNTA BRIDA		
77	3013104	•		SCHERMO	FLANGE GASKET	JOINT ISOLANT	FLANSCHDICHTUNG	JUNTA BRIDA		
78	20032623	•	•	COFANO	COVER	CAPOT	VERKLEIDUNG	ENVOLVENTE		B
79	3012381	•		MOTORE POMPA	PUMP MOTOR	MOTEUR POMPE	PUMPENMOTOR	MOTOR BOMBA		C
80	3013224	•		GRUPPO GIUNZIONE	DRIVE COUPLING	ACCOUPEMENT	KUPPLUNG	ACOPLADOR IMPULSOR		A
81	20040297	•		ANELLO OR	O-RING	JOINT TORIQUE	O-RING-DICHTUNG	JUNTA TÓRICA		B
82	3013211	•		POMPA	PUMP	POMPE	PUMPE	BOMBA		C
83	20026301	•	•	GUARNIZIONE	SEAL	JOINT	DICHTUNG	JUNTA		B
84	20039361	•	•	VALVOLA NON RITORNO	VALVE NOT RETURN	VANNE PAS RETOUR	VENTIL NICHT RÜKHOL	VÁLVULA NO DE VUELTA		B
85	20041352	•	•	CUSCINETTO	BEARING	ROULEMENT	LAGER	COJINETE		C

*

RICAMBI CONSIGLIATI - ADVISED PARTS - RECHANGE CONSEIL - EMPFOHLENE ERSATZTEILE - RECAMBIOS ACONSEJADOS

A = Ricambi per dotazione minima - Spare parts for minimum fittings - Pièces détachées pour équipement minimum - Ersatzteile für minimale Ausstattung - Recambios para equipamiento mínimo

A+B = Ricambi per dotazione base di sicurezza - Spare parts for basic safety fittings - Pièces détachées pour équipement standard de sécurité - Ersatzteile für Sicherheitsgrundausrüstung - Recambios para equipamiento básico de seguridad

A+B+C = Ricambi per dotazione estesa di sicurezza - Spare parts for extended safety fittings - Pièces détachées pour équipement complet de sécurité - Ersatzteile für erweiterte Sicherheitsausrüstung - Recambios para equipamiento general de seguridad

The logo for RIELLO, consisting of the word "RIELLO" in a bold, red, sans-serif font.

RIELLO S.p.A.
I-37045 Legnago (VR)
Tel.: +39.0442.630111
[http:// www.riello.it](http://www.riello.it)
[http:// www.rielloburners.com](http://www.rielloburners.com)