

- I** Bruciatori policombustibile kerosene e gasolio/gas
- GB** Dual fuel kerosene and gas oil/gas burners
- F** Brûleurs mixtes kérosène et fioul/gaz
- D** Mehrstoffbrenner Kerosin und Öl/Gas
- E** Quemadores policombustible queroseno y gasóleo/gas

Funzionamento bistadio progressivo o modulante
Two stage progressive or modulating operation
Fonctionnement à 2 allures progressif ou modulant
Zweistufig gleitender oder modulierender Betrieb
Funcionamiento a dos llamas progresivas o modulante

CODICE - CODE CÓDIGO	MODELLO - MODEL - MODELE MODELL - MODELO	TIPO - TYPE - TYP
20034250	RLS 500/M MX	1300 T

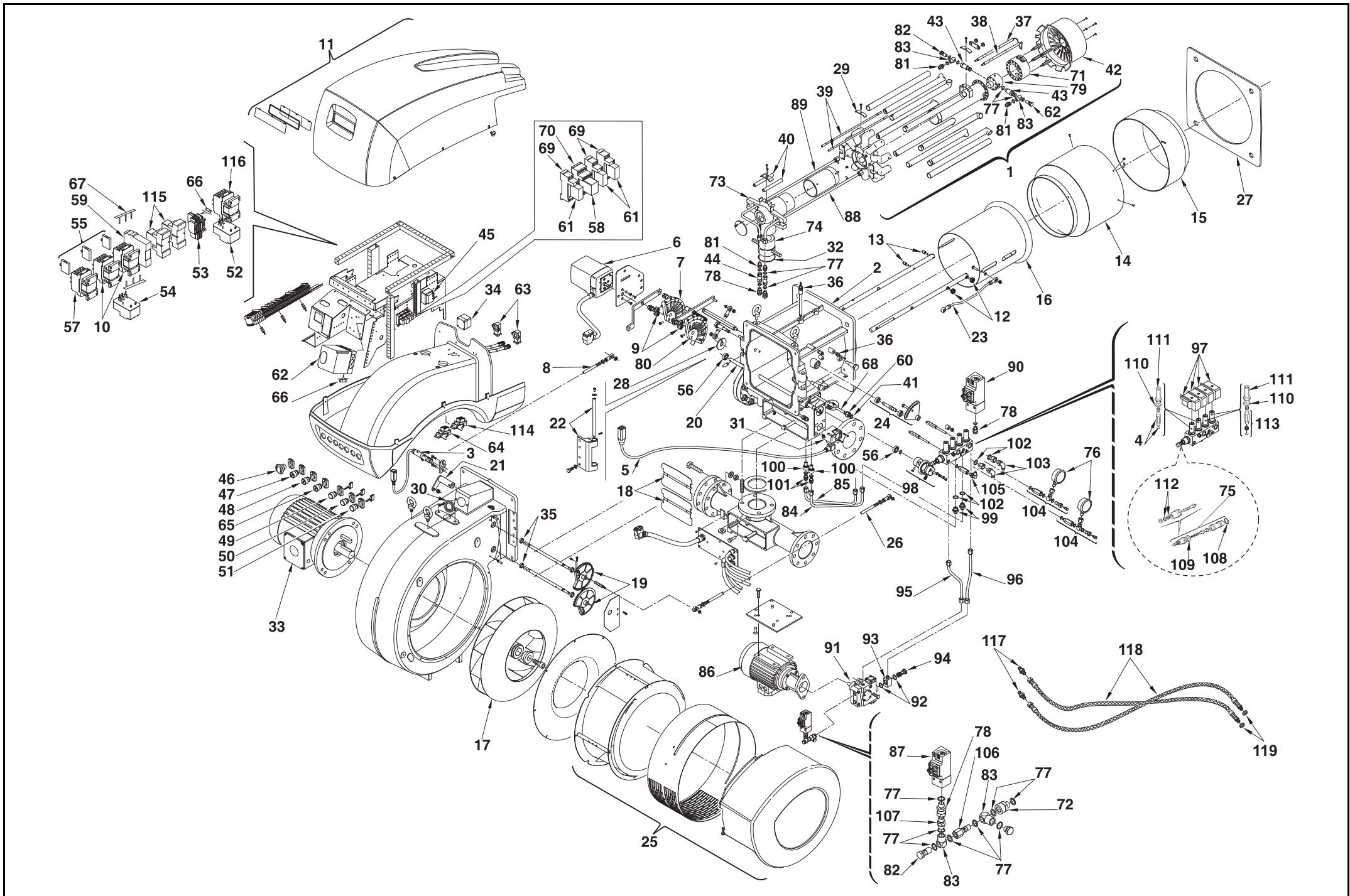

N.	COD.	DESCRIZIONE	DESCRIPTION	DESCRIPTION	BESCHREIBUNG	DENOMINACION	MATRICOLA BRUCIATORE BURNER SERIAL NUMBER MATRICULE BRULEUR BRENNER KENN-NUMMER MATRICULA QUEMADORES	*
1	3014227	TESTA DI COMBUSTIONE	COMBUSTION HEAD	TÊTE DE COMBUSTION	VERBRENNUNGSKOPF	CABEZAL DE COMBUSTIÓN		
2	3013639	MANICOTTO	MANIFOLD	MANCHON	GASANSCHLUSS	MANGUITO		
3	20005518	FOTOCPELLULA UV	UV CELL	PHOTOCELLULE UV	UV PHOTOZELLE	FOTORESISTENCIA UV		A
4	3014198	NUCLEO	CORE	NOYAU	KERN	NÚCLEO		
5	3013303	COLLEGAMENTO PRESSO- STATO GAS	GAS PRESSURE SWITCH CONNECTION	CABLE DE CONNEXION PRES- SOSTAT GAZ	GASDRUCKWÄCHTER VERBIN- DUNG	CABLE CONEXIÓN PRESO- STATO DE GAS		A
6	20005519	GRUPPO SERVOMOTORE	SERVOMOTOR ASSEMBLY	GROUPE SERVOMOTEUR	STELLANTRIEBSGRUPPE	GRUPO SERVOMOTOR		B
7	3013865	CAMMA ARIA	AIR CAM	AIR CAME	LUFTNOCKEN	EXCÉNTRICO AIRE		C
8	3014122	TIRANTE	TIE ROD	TIRANT	GESTÄNGE	TIRANTE		C
9	3013652	PERNO	BAR	GLISSIERE	BOLZEN	PERNO		C
10	3013978	CONTATTORE	CONTACTOR	CONTACTEUR	SCHÜTZ	CONTACTOR		C
11	3013310	COFANO	COVER	COFFRET	VERKLEIDUNG	ENVOLENTE		
12	3013965	PERNO	BAR	GLISSIERE	BOLZEN	PERNO	≤ 02241005417	C
12	20038376	PERNO	BAR	GLISSIERE	BOLZEN	PERNO	≥ 02241005418	C
13	3013964	PERNO	BAR	GLISSIERE	BOLZEN	PERNO	≤ 02241005417	C
13	20038375	PERNO	BAR	GLISSIERE	BOLZEN	PERNO	≥ 02241005418	C
14	3013641	CILINDRO	SLEEVE	CYLINDRE	ZYLINDER	CILINDRO		
15	3014200	IMBUTO FIAMMA	END CONE	EMBOUT GUEULARD	FLAMMENROHR	TUBO EXTREMO		B
16	3014199	OTTURATORE	SHUTTER	OBTURATEUR	SCHIEBER	OBTURADOR	≤ 02241005417	C
16	20041804	OTTURATORE	SHUTTER	OBTURATEUR	SCHIEBER	OBTURADOR	≥ 02241005418	C
17	3013962	GIRANTE	FAN	TURBINE	GEBLÄSERAD	TURBINA		C
18	3013319	SERRANDA ARIA	AIR DAMPER	VOLET D'AIR	LUFTKLAPPE	REGISTRO DEL AIRE		
19	3013320	INGRANAGGIO	GEAR TRAIN	EN GRENAGE	RÄDERPAAR	ENGRANAJE		
20	3014170	ALBERO	SHAFT	PIVOT	NOCKEN	EJE		C
21	3013971	LEVA	LEVER	LEVIER	HEBEL	PALANCA		C
22	3013323	CERNIERA	HINGE	CHARNIERE	SCHARNIER	BISAGRA		
23	3013324	TIRANTE INTERNO	INTERNAL TIE ROD	TIRANT INTERIEUR	INNERES GESTÄNGE	TIRANTE INTERNO		C
24	3014204	GRUPPO LEVE	LEVER ASSEMBLY	GROUPE LEVIER	HEBELSYSTEM	GRUPO LEVAS	≤ 02241005417	
24	20041313	GRUPPO LEVE	LEVER ASSEMBLY	GROUPE LEVIER	HEBELSYSTEM	GRUPO LEVAS	≥ 02241005418	
25	3013326	GRUPPO ASPIRAZIONE	AIR INTAKE ASSEMBLY	GROUPE ASPIRATION	ANSAUGGRUPPE	GRUPO ASPIRACIÓN		
26	3013327	TIRANTE ESTERNO	EXTERNAL TIE ROD	TIRANT EXTERIEUR	AUSSERES GESTÄNGE	TIRANTE ESTERNO		C
27	3013675	SCHERMO	FLANGE GASKET	JOINT ISOLANT	FLANSCHDICHTUNG	JUNTA BRIDA		A
28	3014195	QUADRANTE	SCALE LEVER	LEVIER DE BALANCE	SKALAHEBEL	PALANCA DE LA ESCALA		
29	3012872	CAVALLOTTO	U BOLT	CAVALIER	BÜGELBOLZEN	FIJACION ELECTRODO		
30	3008663	VETRINO	VIEWING PORT	REGARD	SCHAUGLAS	PLATINA		C
31	3012197	PRESSOSTATO GAS	GAS PRESSURE SWITCH	PRESSOSTAT GAZ	GASDRUCKWÄCHTER	PRESOSTATO DE GAS		B
32	3007170	O-RING	O-RING	JOINT TORIQUE	O-RING	JUNTA TÓRICA		B
33	3014224	MOTORE 12 kW	MOTOR 12 kW	MOTEUR 12 kW	MOTOR 12 kW	MOTOR 12 kW		C
34	3013449	PRESSOSTATO ARIA	AIR PRESSURE SWITCH	PRESSOSTAT AIR	LUFTDRUCKWÄCHTER	PRESOSTATO DEL AIRE		A
35	3012795	CUSCINETTO	BEARING	ROULEMENT	LAGER	COJINETE		C
36	3005447	PRESA DI PRESSIONE	PRESSURE TEST POINT	PRISE DE PRESSION	DRUCKENTNAHMESTELLE	TOMA DE PRESIÓN		C

N.	COD.	DESCRIZIONE	DESCRIPTION	DESCRIPTION	BESCHREIBUNG	DENOMINACION	MATRICOLA BRUCIATORE BURNER SERIAL NUMBER MATRICULE BRULEUR BRENNER KENN-NUMMER MATRICULA QUEMADORES	*
37	3013546	ELETTRODO	ELECTRODE	ELECTRODE	ELEKTRODE	ELECTRODO		A
38	3013547	ELETTRODO	ELECTRODE	ELECTRODE	ELEKTRODE	ELECTRODO		A
39	3012281	COLLEGAMENTO ELET- TRODO	HIGH VOLTAGE LEAD	CABLE DE CONNEXION ELECTRODE	ELEKTRODEVERBINDUNG	CABLE CONEXIÓN ELECTRODO		A
40	3012258	ISOLATORE	INSULATOR	PORCELAINE D'ELECTRODE	ISOLATOR	AISLADOR		A
41	3007029	O-RING	O-RING	JOINT TORIQUE	O-RING	JUNTA TÓRICA		B
42	3014171	ELICA	DIFFUSER DISC	ACCROCHE FLAMME	STAUSCHEIBE	DISCO ESTABILIZADOR		A
43	3013460	RACCORDO	CONNECTOR	MAMELON	NIPPEL	RACORD		C
44	3013461	VALVOLA NON RITORNO	VALVE NOT RETURN	VANNE PAS RETOUR	RÜCKSCHLAGVENTIL	VALVOLA NO DE VUELTA		B
45	3012488	TRASFORMATORE	TRANSFORMER	TRANSFORMATEUR	ZÜNDTRANSFORMATOR	TRANSFORMADOR		B
46	3013333	PULSANTE DI EMERGENZA	SAFETY BUTTON	BOUTON DE SÉCURITÉ	SICHERHEITSTASTE	PULSADOR DE LA EMERGEN- CIA		C
47	3013334	SELETTORE AUTO/MAN	SWITCH AUTO/MAN	SÉLECTEUR AUTO/MAN	SCHALTER AUTO/MAN	SELECTIVO AUTO/MAN		C
48	3013335	SELETTORE + / -	SWITCH + / -	SÉLECTEUR + / -	SCHALTER + / -	SELECTIVO + / -		C
49	3013366	INDICATORE LUMINOSO VERDE	GREEN SIGNAL LIGHT	SIGNAL LUMINEUX VER	GRÜNE LEUCHTANZEIGE	INDIC. LUMINOSO VERDE		A
50	3013353	INDICATORE LUMINOSO ROSSO	RED SIGNAL LIGH	SIGNAL LUMINEUX ROUGE	ROTE LEUCHTANZEIGE	INDIC. LUMINOSO ROJO		A
51	3013354	PULSANTE LUMINOSO ROSSO DI RESET	RED RESET PUSH-BUTTON	BOUTON ROUGE DE RESET	ROTER KNOPF FÜR RESET	BOTÓN LUMINOSO ROJO DE RESET		C
52	20005527	RELÈ TERMICO	OVERLOAD	RELAIS THERMIQUE	ÜBERSTROMAUSLÖSER	RELÈ TERMICO		C
53	3013359	MORSETTIERA AUSILIARIA	AUXILIARY TERMINAL STRIP	PLAQUE À BORNES AUXILIAIRE	HILFSKLEMMENBRETT	REGLETA CONEXIONES AUXILIARIA		
54	20005524	RELÈ TERMICO	OVERLOAD	RELAIS THERMIQUE	ÜBERSTROMAUSLÖSER	RELÈ TERMICO		C
55	3012783	CONTATTO AUSILIARIO	AUXILIARY CONTACT	CONTACTES AUXILIAIRE	HILFSKONTAKT	CONTACTO AUXILIAR		B
56	3013650	CUSCINETTO	BEARING	ROULEMENT	LAGER	COJINETE		C
57	3013979	CONTATTORE	CONTACTOR	CONTACTEUR	SCHÜTZ	CONTACTOR		C
58	3012368	RELÈ	RELAY	RELAIS	RELAIS	RELÉ		
59	20073824	TEMPORIZZATORE	TIMER	TEMPORISATEUR	ZEITRELAIS	RETARDATOR		B
60	3013653	RACCORDO	CONNECTOR	MAMELON	NIPPEL	RACORD		C
61	3012842	RELÈ	RELAY	RELAIS	RELAIS	RELÉ		C
62	3006090	APPARECCHIATURA	CONTROL BOX	BOITE DE CONTROLE	STEUERGERÄT	CAJA CONTROL		B
63	3013363	PRESA 7 POLI 90°	7 POLE SOCKET 90°	PRISE À 7 PÔLES 90°	7-POLIGE STECKDOSE 90°	CONECTOR HEMBRA DE 7 CONTACTOS 90°		C
64	3013364	PRESA 17 POLI	17 POLE SOCKET	PRISE À 17 PÔLES	17-POLIGE STECKDOSE	CONECTOR HEMBRA DE 17 CONTACTOS		C
65	3013474	SELETTORE GAS/OLIO	SWITCH GAS/OIL	SÉLECTOR GAZ/OIL	SCHALTER GAS/ÖL	SELECTIVO GAS/OLEO		C
66	3014106	FUSIBILE 6,3 A	FUSE 6.3 A	FUSIBLE 6,3 A	SCHMELZSICHERUNG 6,3 A	FUSIBLE 6,3 A		
67	20005522	CONNESSIONI STELLA /TRIANGOLO	STAR / DELTA POWERED CONNECTIONS	CONNEXIONS ÉTOILE / TRIANGLE	STERN / DREIECK VERBINDUNGEN	CONEXIONES ESTRELLA / TRIÁNGULO		
68	3014172	ALBERO	SHAFT	PIVOT	NOCKEN	EJE		C
69	3012841	ZOCCOLO	BASE	SOCLE	SOCKEL	ZOCALO		C
70	3003935	ZOCCOLO	BASE	SOCLE	SOCKEL	ZOCALO		C

N.	COD.	DESCRIZIONE	DESCRIPTION	DESCRIPTION	BESCHREIBUNG	DENOMINACION	MATRICOLA BRUCIATORE BURNER SERIAL NUMBER MATRICULE BRULEUR BRENNER KENN-NUMMER MATRICULA QUEMADORES	*
71	3014201	TAZZA	AIR DIFFUSER	DIFFUSEUR D'AIR	STAUSCHEIBE	DIFUSOR DEL AIRE		C
72	3003589	RACCORDO	CONNECTOR	MAMELON	NIPPEL	RACORD		C
73	3014118	GOMITO	ELBOW	COUDE	GASSCHLITTEN	CODO		
74	3014117	VOLANTINO	CONTROL WHEEL	ROUE DE CONTROLE	REGELRAD	RUEDA DE CONTROL		
75	3014173	GRUPPO REGOLATORE	REGULATOR	GROUPE RÉGULATEUR	REGLERGRUPPE	CONJUNTO REGULADOR		
76	3006140	MANOMETRO	GAUGE	MANOMÈTRE	DRUCKMESSER	MANÓMETRO		
77	3007079	GUARNIZIONE	SEAL	JOINT	DICHTUNG	JUNTA		B
78	3013462	RACCORDO	CONNECTOR	MAMELON	NIPPEL	RACORD		
79	3014228	POLVERIZZATORE	SPRAY NOZZLE	BUSE D'INJECTION GICLEUR	EINSPRITZDÜSE	PULVERIZADOR		
80	3012864	CAMMA GAS	GAS CAM	GAZ CAME	GAS-NOCKEN	EXCÉNTRICO GAS		
81	3012549	RACCORDO	CONNECTOR	MAMELON	NIPPEL	RACORD		C
82	3003006	PERNO	BAR	GLISSIERE	BOLZEN	PERNO		C
83	3012455	RACCORDO	CONNECTOR	MAMELON	NIPPEL	RACORD		C
84	3014174	TUBO	PIPE	TUYAU	ROHR	TUBO		
85	3014175	TUBO	PIPE	TUYAU	ROHR	TUBO		
86	3012283	MOTORE POMPA	PUMP MOTOR	MOTEUR POMPE	PUMPENMOTOR	MOTOR BOMBA		
87	3014167R	PRESSOSTATO OLIO	OIL PRESSURE SWITCH	PRESSOSTAT FIOUL	ÖLDRUCKWÄCHTER	PRESÓSTATO ACEITE		A
88	3014202	TUBO	PIPE	TUYAU	ROHR	TUBO		
89	3014203	TUBO	PIPE	TUYAU	ROHR	TUBO		
90	3014180R	PRESSOSTATO OLIO	OIL PRESSURE SWITCH	PRESSOSTAT FIOUL	ÖLDRUCKWÄCHTER	PRESÓSTATO ACEITE		A
91	3006410	POMPA	PUMP	POMPE	PUMPE	BOMBA		
92	3007164	GUARNIZIONE	SEAL	JOINT	DICHTUNG	JUNTA		B
93	3003055	RACCORDO	CONNECTOR	MAMELON	NIPPEL	RACORD		C
94	3006184	PERNO	BAR	GLISSIERE	BOLZEN	PERNO		C
95	3014176	TUBO	PIPE	TUYAU	ROHR	TUBO		
96	3014177	TUBO	PIPE	TUYAU	ROHR	TUBO		
97	3003001	BOBINA	COIL	BOBINE E.V.	MAGNETVENTIL - SPULE	BOBINA		B
98	3003186	CUSCINETTO	BEARING	PALIER	LAGER	COJINETE		
99	3009084	RACCORDO	CONNECTOR	MAMELON	NIPPEL	RACORD		C
100	3013557	RACCORDO	CONNECTOR	MAMELON	NIPPEL	RACORD		C
101	3012549	RACCORDO	CONNECTOR	MAMELON	NIPPEL	RACORD		C
102	3007082	GUARNIZIONE	SEAL	JOINT	DICHTUNG	JUNTA		B
103	3014178	RACCORDO	CONNECTOR	MAMELON	NIPPEL	RACORD		C
104	3013998	RACCORDO	CONNECTOR	MAMELON	NIPPEL	RACORD		C
105	3014179	RACCORDO	CONNECTOR	MAMELON	NIPPEL	RACORD		C
106	3005804	PERNO	BAR	GLISSIERE	BOLZEN	PERNO		C
107	3009046	RACCORDO	CONNECTOR	MAMELON	NIPPEL	RACORD		C
108	3003201	O-RING	O-RING	JOINT TORIQUE	O-RING-DICHTUNG	JUNTA TÓRICA		
109	3003204	O-RING	O-RING	JOINT TORIQUE	O-RING-DICHTUNG	JUNTA TÓRICA		
110	3007081	GUARNIZIONE	SEAL	JOINT	DICHTUNG	JUNTA		B
111	3014196	GUAINA	SHEATH	GAINÉ	HÜLSE	VAINA		

N.	COD.	DESCRIZIONE	DESCRIPTION	DESCRIPTION	BESCHREIBUNG	DENOMINACION	MATRICOLA BRUCIATORE BURNER SERIAL NUMBER MATRICULE BRULEUR BRENNER KENN-NUMMER MATRICULA QUEMADORES	*
112	3003203	O-RING	O-RING	JOINT TORIQUE	O-RING-DICHTUNG	JUNTA TÓRICA		
113	3014197	NUCLEO	CORE	NOYAU	KERN	NÚCLEO		
114	3013473	PRESA 8 POLI	8 POLE SOCKET	PRISE À 8 PÔLES	8-POLIGE STECKDOSE	CONECTOR HEMBRA DE 8 CONTACTOS		C
115	20005520	RELÈ + ZOCCOLO	RELAY + BASE	RELAIS + SOCLE	RELAIS + SOCKEL	RELÉ + ZOCALO		
116	20005525	CONTATTORE	CONTACTOR	CONTACTEUR	SCHÜTZ	CONTACTOR		C
117	3006181	RACCORDO	CONNECTOR	MAMELON	NIPPEL	RACORD		C
118	20034085	TUBO FLESSIBILE	HOSE	TUYAU FLEXIBLE	ÖLSCHLAUCH	TUBO FLEXIBLE		A
119	3007164	GUARNIZIONE	SEAL	JOINT	DICHTUNG	JUNTA		B

*

RICAMBI CONSIGLIATI - ADVISED PARTS - RECHANGE CONSEIL - EMPFOHLENE ERSATZTEILE - RECAMBIOS ACONSEJADOS

A = Ricambi per dotazione minima - Spare parts for minimum fittings - Pièces détachées pour équipement minimum - Ersatzteile für minimale Ausstattung - Recambios para equipamiento mínimo

A+B = Ricambi per dotazione base di sicurezza - Spare parts for basic safety fittings - Pièces détachées pour équipement standard de sécurité - Ersatzteile für Sicherheitsgrundausrüstung - Recambios para equipamiento básico de seguridad

A+B+C = Ricambi per dotazione estesa di sicurezza - Spare parts for extended safety fittings - Pièces détachées pour équipement complet de sécurité - Ersatzteile für erweiterte Sicherheitsausstattung - Recambios para equipamiento general de seguridad

RIELLO

RIELLO S.p.A.
I-37045 Legnago (VR)
Tel.: +39.0442.630111
[http:// www.riello.it](http://www.riello.it)
[http:// www.rielloburners.com](http://www.rielloburners.com)