

Forced draught gas burner



MODEL	TYPE
GAS 6 P/M	536 T80

Thermal power - Output	300 ÷ 1050 kW - 258.000 ÷ 903.000 kcal/h
Operation	- two stages progressive - modulating (kit with controller available upon request)
Fuel	natural gas Pci 8 - 10 kWh/m ³ = 7000 - 8600 kcal/m ³
Minimum gas pressure	for maximum output 12.3 mbar are needed measured at the coupling with nil pressure in the combustion chamber and gas with calorific value of 8600 kcal/m ³
Maximum gas pressure	150 mbar

ELECTRICAL DATA

Motor IE1

Electrical supply		3N ~ 380V 60 Hz
Fan motor	rpm V kW A	3350 220/380 1.5 6.6 - 3.8
Ignition transformer	V1 - V2 I1 - I2	220 V - 1 x 8 kV 1.8 A - 30 mA
Electrical power consumption	kW max	1.7

Motor IE2

Electrical supply		3N ~ 380V 60 Hz
Fan motor	rpm V kW A	3500 220/380 1.5 5.5 - 3.2
Ignition transformer	V1 - V2 I1 - I2	220 V - 1 x 8 kV 1.8 A - 30 mA
Electrical power consumption	kW max	1.7

- 1 - Servomotor controlling air and gas
- 2 - Adjustment cam
- 3 - Power controller (for modulating to be required separately)
- 4 - Control box reset button
- 5 - Servomotor connection
- 6 - Fair leads
- 7 - Wiring terminal block
- 8 - Reset push-button of the motor over load relay
- 9 - Air pressure switch
- 10 - Gas pressure test-point

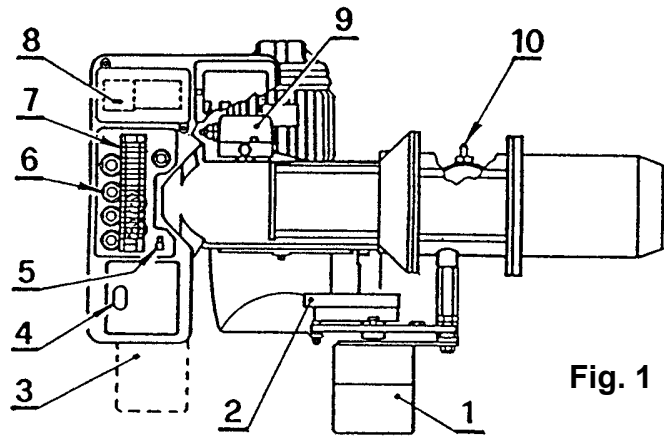
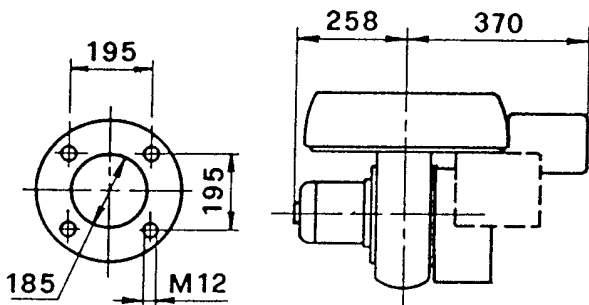

Fig. 1

QUANTITY	ACCESSORIES
1	Flange
1	Gasket
8	Screws
1	Flange gasket

DIMENSIONS

Boiler front-plate drilling



Burner

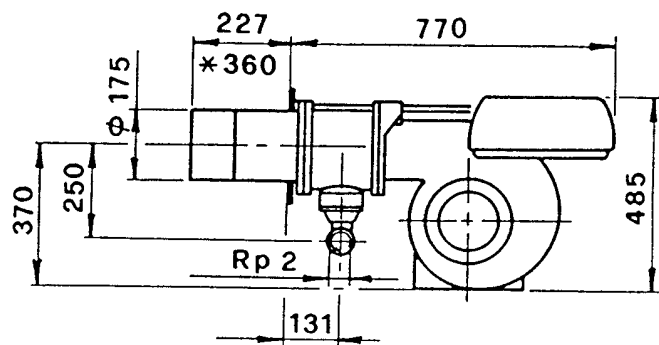

* Length available with special blast tube to be separately required.

COMBUSTION CHAMBER PRESSURE - MAXIMUM OUTPUT

Minimum output: 300 kW - 258.000 kcal/h

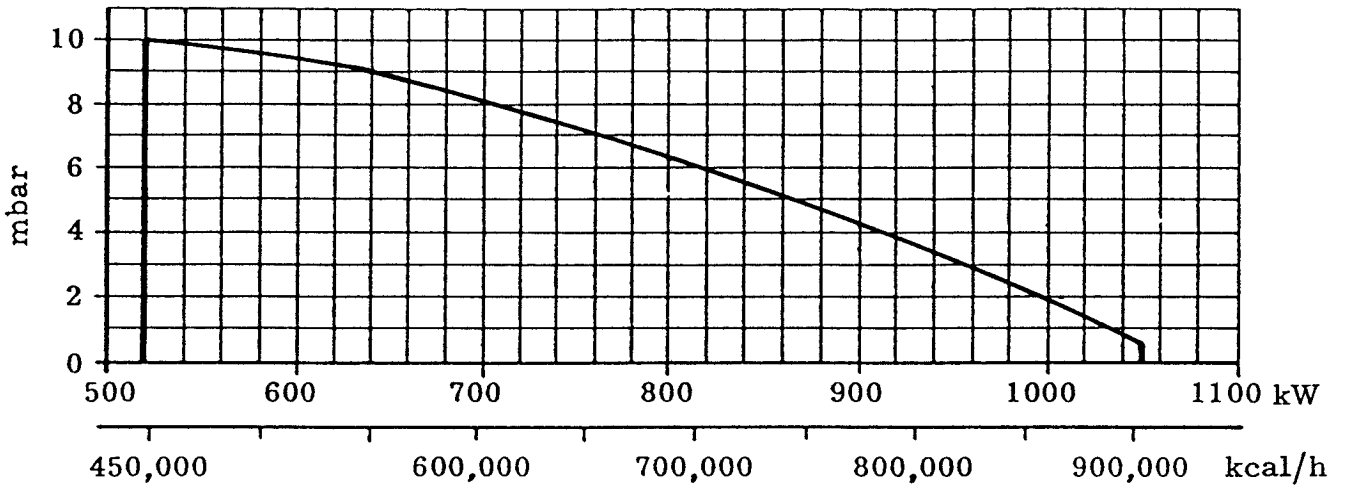

MINIMUM GAS PRESSURE - OUTPUT

Pressure: detected at the pressure test-point 10) (fig. 1) with oil mbar into the combustion chamber. Should the combustion chamber be pressurized, the pressure necessary will be that of the graph plus the pressurization value.

Example: to obtain 800 kW it is necessary a gas pressure of 11 mbar and the combustion head set as indicated at page 8.

If the combustion chamber is pressurized at 2 mbar, the pressure detected at the test-point 10) is: $11+2=13$ mbar.

If this value is too high, for very low gas pipework pressures, the gas gear 6) (page 8) could be more open. Do not decrease the pressure at the coupling under the values shown in the diagram.

Output: the maximum value is obtainable with gas Pci 8600 kcal/m³.

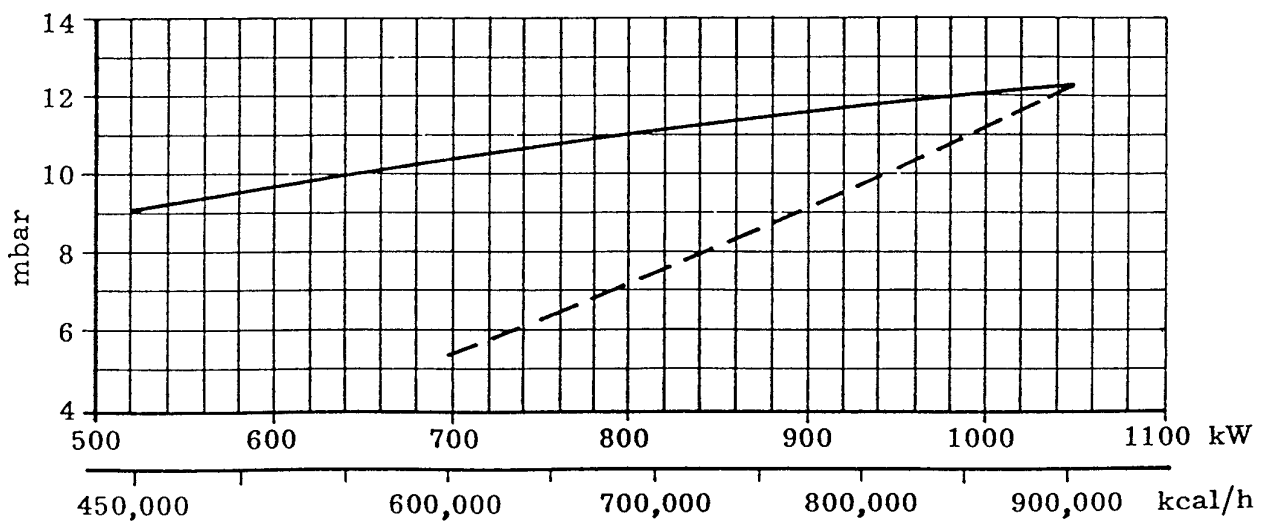

MOUNTING TO THE BOILER

Separately the blast tube from the burner body by loosening the screws 7) and 3), fix the blast tube to the boiler front plate 5) using the gasket 6) provided. Insert the burner on the holding bars 4) and fasten the screws 7) and 3).

The combustion head adjustment should be carried out as follows: Loosen the screws 2) UNHOOK THE TENSION ROD OF THE AIR DAMPER 1) remove the connecting lead of the servomotor, withdraw the group A) from the group B).

After the setting, re-assemble and verify that the tension rod of the air damper was locked.

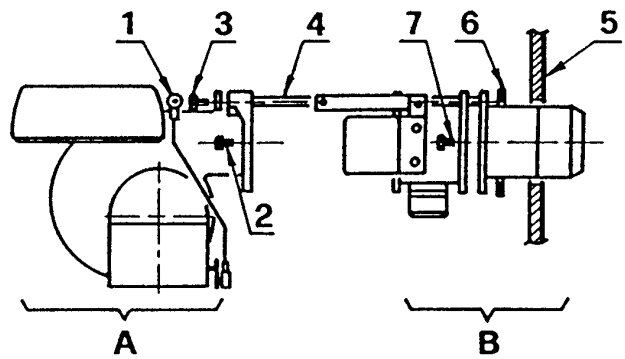

GAS SUPPLY

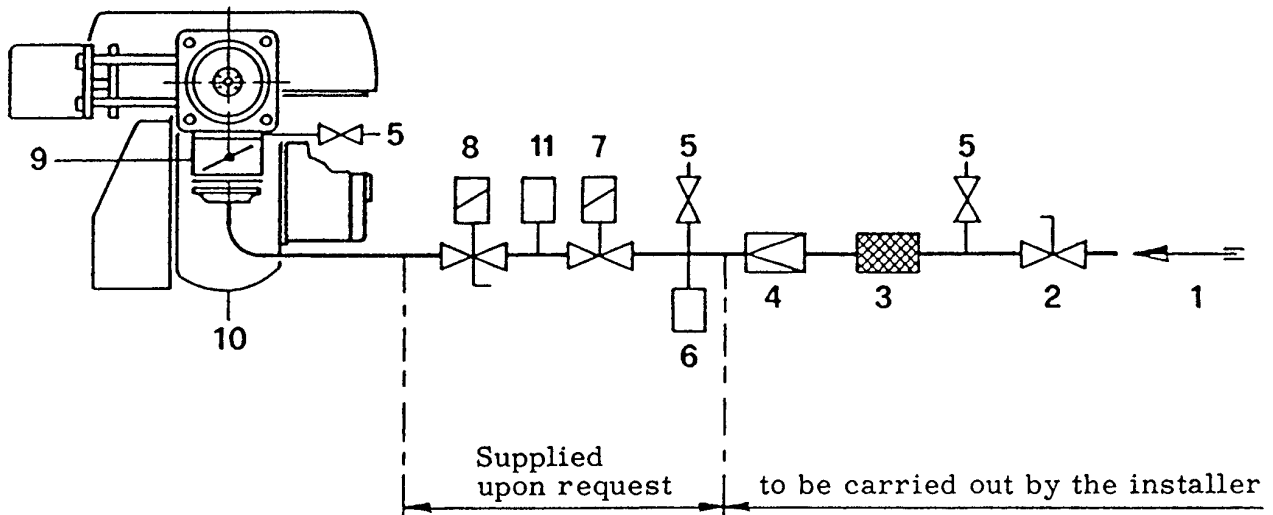

- 1 - Gas pipe line
- 2 - Cock valve
- 3 - Filter
- 4 - Pressure stabilizer
- 5 - Pressure test-point

- 6 - Minimal gas pressure switch
- 7 - Safety valve
- 8 - Adjustment valve
- 9 - Adjusting throttle valve
- 10- Burner
- 11- Gas Leak control device

BURNER ELECTRICAL WIRING

(carried out by the factory)

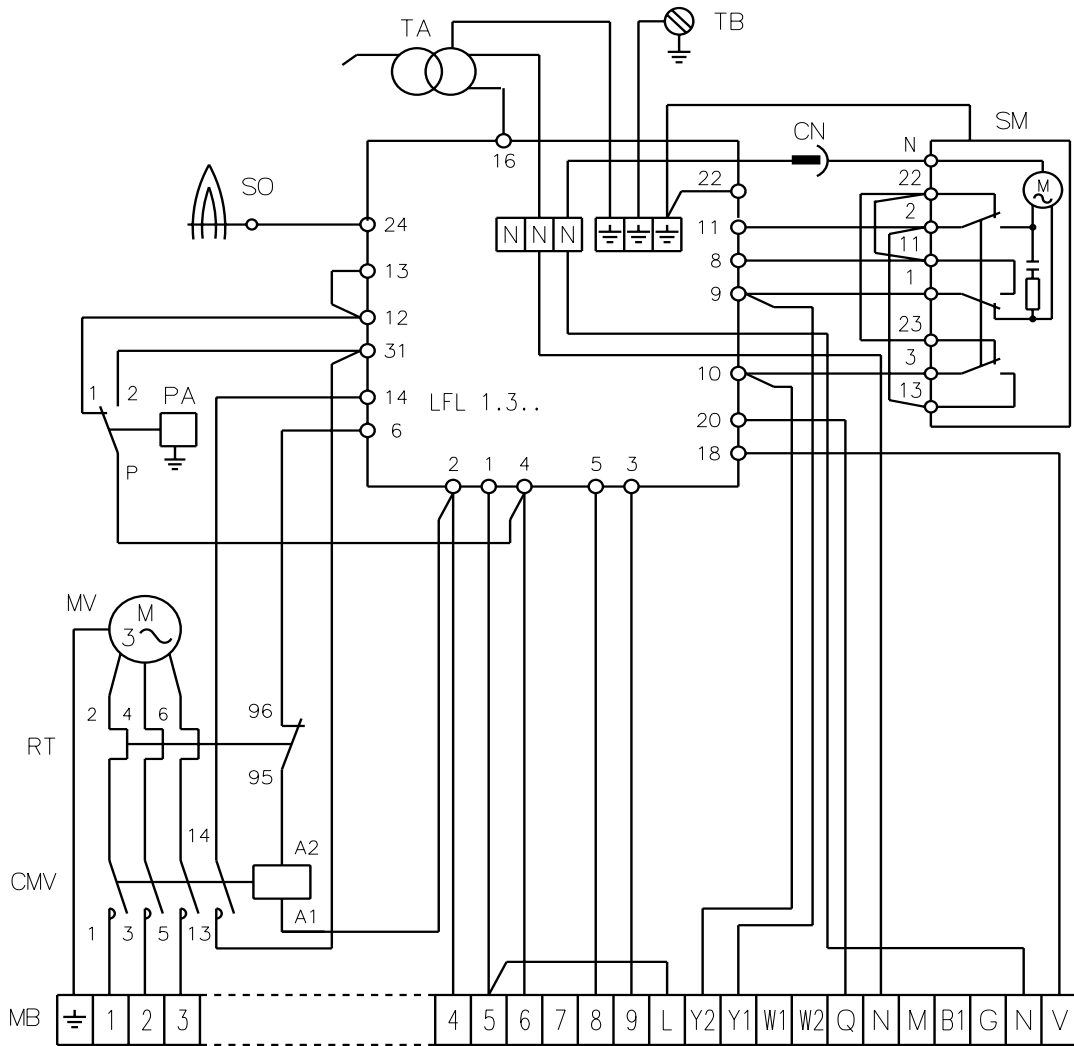

D3377

ELECTRICAL CONNECTIONS TO THE WIRING TERMINAL BLOCK (to be carried out by the installer)

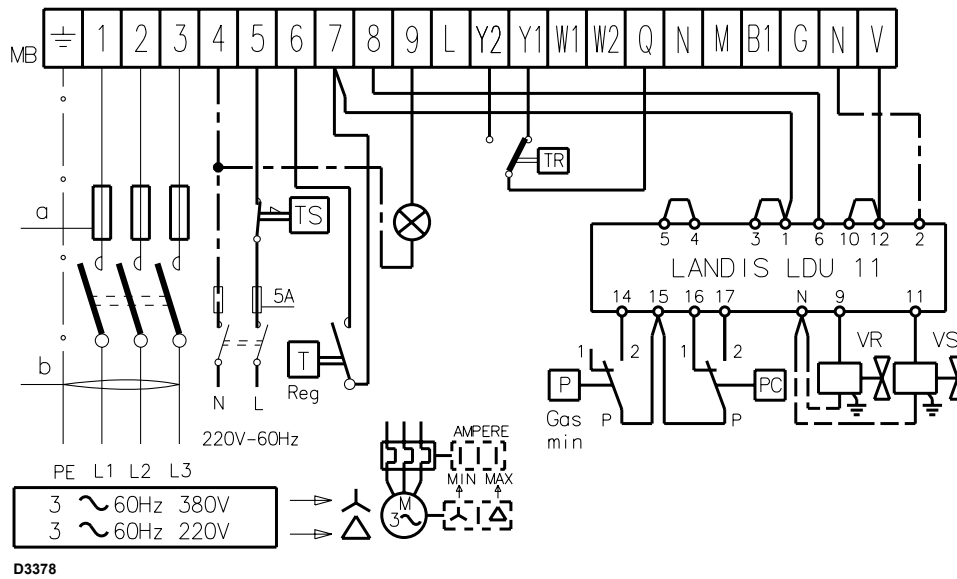

RWF 40 CONNECTION

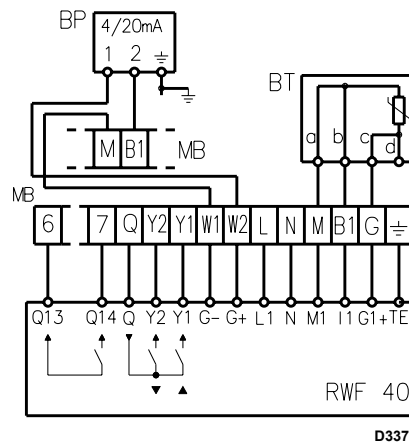

	4-5 P/M		GAS 6 P/M		GAS 7 P/M	
	220V	380V	220V	380V	220V	380V
a AMPERE	6	16	10	25	16	
b mm ²	1,5	1,5	1,5	2,5	1,5	

NOTE

- The electrical wiring carried out by the installer must be in compliance with the rules in force in the Country.
- Leads minimal section 1 mm².
- Adjustment for the motor thermal relay:
 - at the beginning of the scale for 380V
 - at the end of the scale for 220V
- Burners with non-stop operation. For safety reasons, this type of burner must be stopped every 24 hours of operation, by means of an hours-counter to be connected in series with the adjustment devices.

FIXING OF THE ELECTRICAL WIRES

All the electrical wires, which are to be connected to the terminal block 7) (fig. 1) shall pass through the fair leads 6) (fig. 1) as per this scheme.

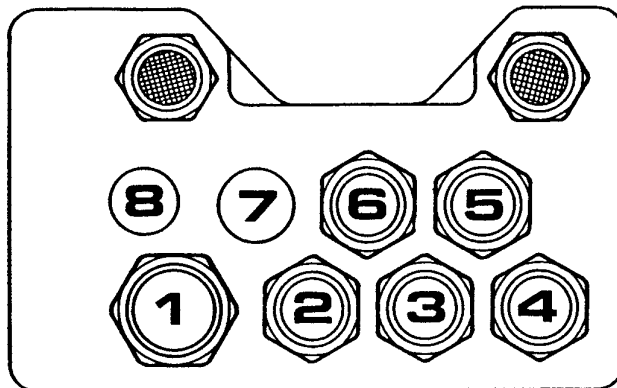

- | | |
|-------------------------------------------------------------|---------------------------------------------------------------|
| 1 - Three phase supply: | fair lead Pg 21 |
| 2 - Single phase supply: | fair lead Pg 13.5 |
| 3 - Adjustment thermostat: | fair lead Pg 13.5 |
| 4 - Safety thermostat: | fair lead Pg 13.5 |
| 5 - Gas train: | fair lead Pg 13.5, sheath \varnothing 13 |
| 6 - 2nd stage thermostat:
(probe for modulating version) | fair lead Pg 13.5 |
| 7 - Pre-sheared hole: | fair lead Pg 13.5 (for power controller - modulating version) |
| 8 - Pre-sheared hole | |

Further prospective signals or controls can be connected to the burner wiring terminal board by removing the metal weldnuts from the pre-sheared holes and inserting a common fair lead for the passage and the clamping of the leads.

NOTES

- Do not exchange the neutral wire with the phase (avoid the plug-pin connection).
- Carry out a safe earth connection.
- Check the stop of the burner, by opening the boiler thermostat and the burner lock-out, by disconnecting the lead from the flame probe.

WARNING

When closing the burner on its slide-bars, pull towards the outside the high voltage cable and the cable of the flame detection probe, till to little tension.

START-UP

Air-purge: Loosen the screws placed on the minimal gas pressure switch mounted on the gas train.

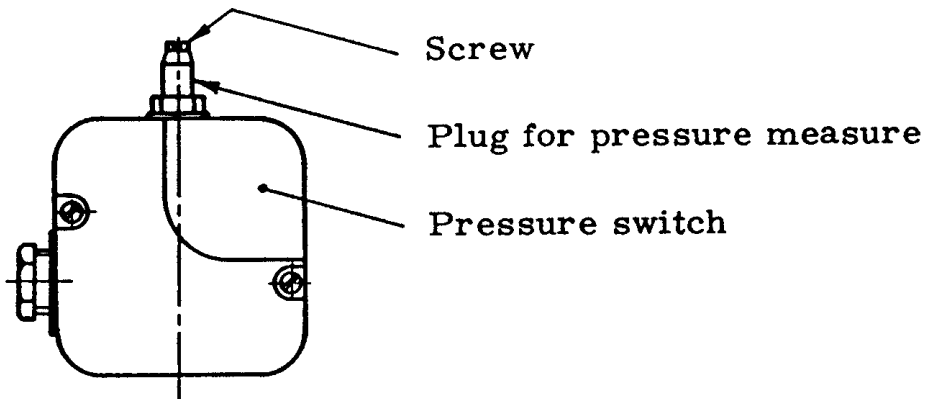

AIR PRESSURE SWITCH

The air pressure switch setting shall be carried out after having set all other adjustments of the burner and the air pressure switch shall be at its lowest set-point.

When the burner is operating, increase the adjustment pressure by turning - slowly - clockwise the knob till reaching the burner lock-out. There after, turn the knob anticlockwise for 1 mbar and repeat the burner start-up for checking the regularity: if lock-out intervenes turn the knob anticlockwise for 0.5 mbar.

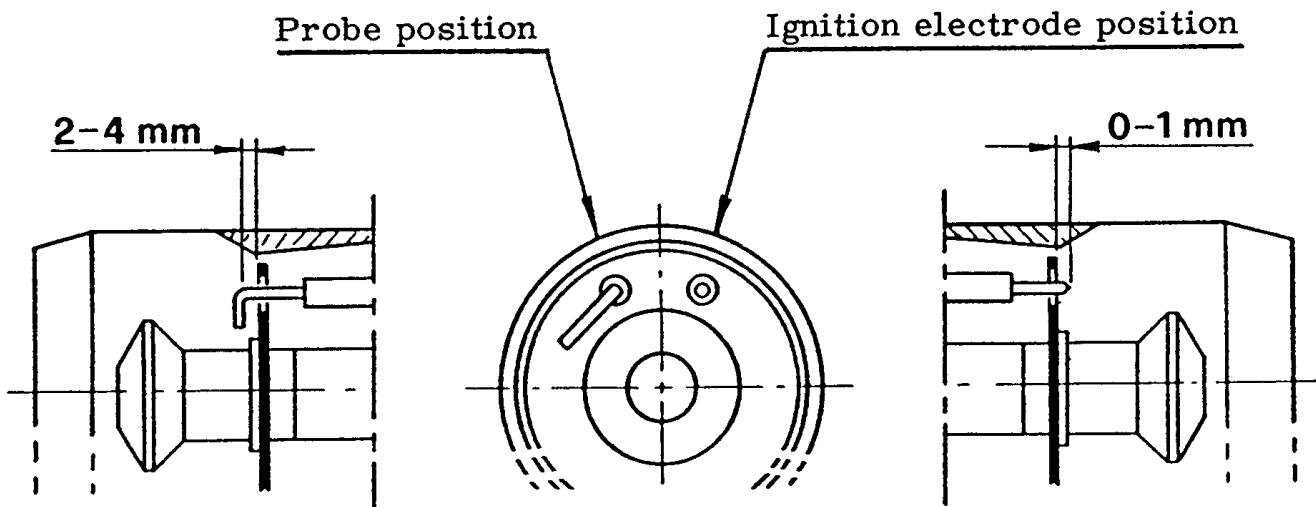
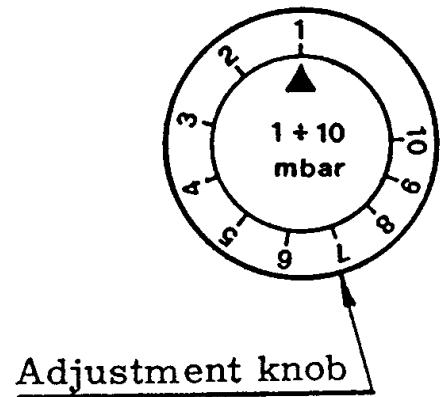

CAUTION

Do not turn the ionization probe, maintain the drawing position; should it be close to the ignition electrode, damage may occur to the control box amplifier.

ADJUSTMENT BURNER

1 - COMBUSTION HEAD

Two separate adjustments have to be made: air and gas.

These adjustments can be carried out when the burner is still open, during the installation (see page 3 - fixing to the boiler).

Air setting

Loosen the two screws 1) and move the internal part of the combustion head 2) so that its rear edge 3) is coincident with the desired set-point on the plate 4). Tighten the screws 1).

Gas setting

Loosen the screw 5), move the ring 6) so that the pointer 7) is coincident with the desired set-point 8). Tighten the screw 5).

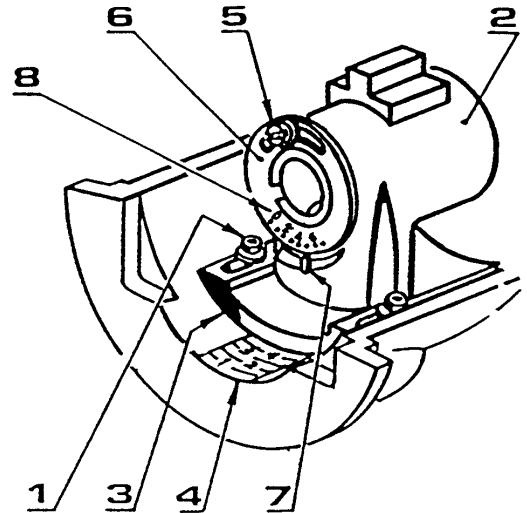

Attention: The set-point number is the same for air and gas setting and is given by the following diagram.

Example: The burner is installed on a boiler of 810 kW, assuming an efficiency of 90% the burner output should be 900 kW. From the diagram it can be seen that the air and gas settings for this rating should be no. 5.

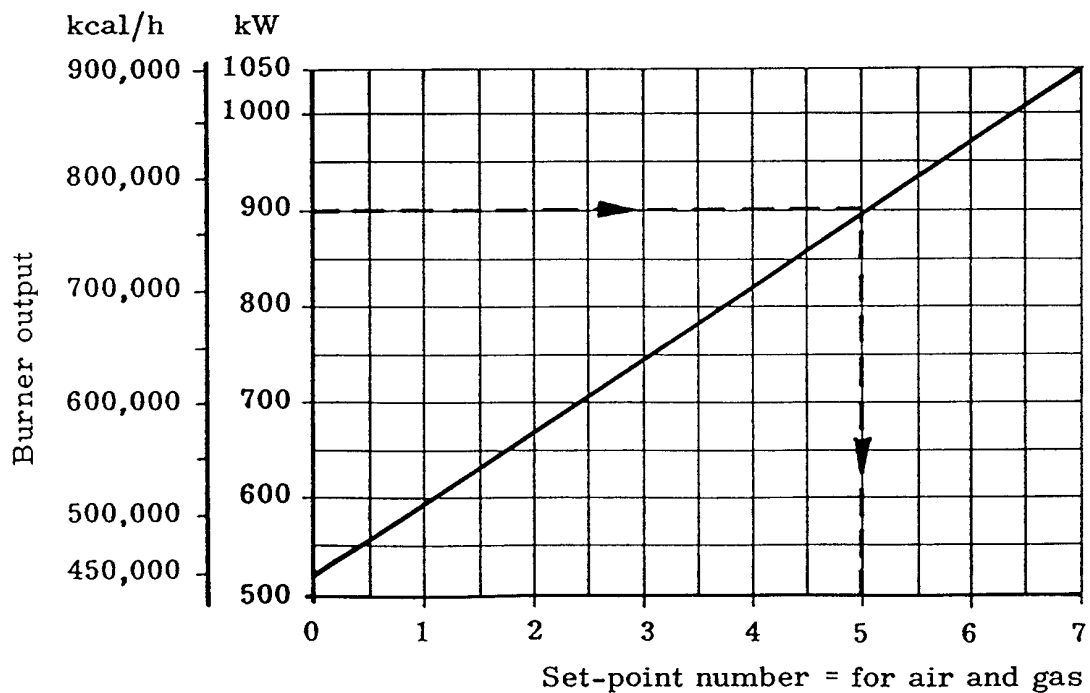

2 - SERVOMOTOR

The servomotor controls the air damper and the gas throttle valve.

It is provided with three adjustable cams controlling the related change-over switches.

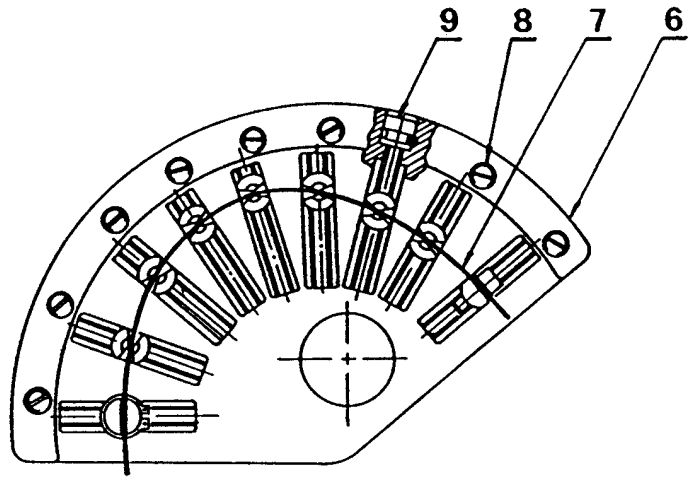
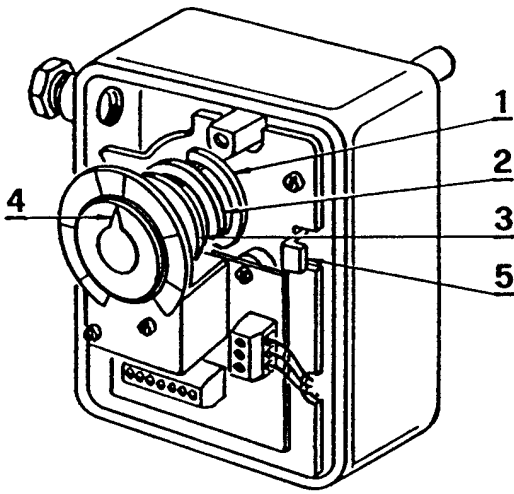

- 1) 1st cam (blue)
- 2) 2nd cam (red)
- 3) 3rd cam (black)
- 4) Pointer
- 5) Motor reset button

- 6) Cam with adjustable profile
- 7) Adjustable profile
- 8) Fastening screws
- 9) Adjusting screws

1st cam: it controls the min. stroke and remains always positioned on 0°, in this way, when the burner is off the air damper is totally closed.

2nd cam: it controls the max. stroke, generally it is positioned on 130°.

3rd cam: it controls the minimal modulating power.

It is set by the factory on 30°: normally this position is the most suitable for the first ignition. Thereafter the installer may vary this setting accordingly with the installation requirements.

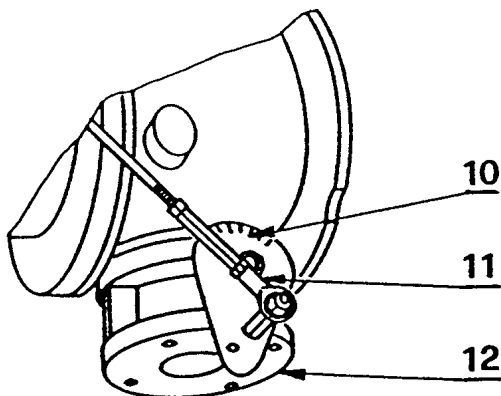

- 10) Throttle valve control sector
- 11) Tension rod
- 12) Gas adjustment shutter

3 - COMBUSTION ADJUSTMENT (References on drawings at page 9)

For the combustion adjustment we suggest to proceed in this way:

- Let the burner starts and after the flame ignites at the minimum output, disconnect the servomotor by opening the connection 5) (page 1) placed on panel.
- Thereafter proceed successively to the adjustment of the maximum, minimal outputs and to the intermediate output.

3.1 - Maximum output setting

Gas

- Disjoint the cam with adjustable profile 6) from the servomotor by re-setting the button 5).
- Turn manually clockwise the cam 6) till to reach the position of 130° (on the edge of the servomotor) in correspondence of the pointer 4). In this way the gas throttle valve 12) is at the max. opening - 90°-
- Join again the cam with adjustable profile 6) to the servomotor by pushing the button 5).

Now set the gas rate by acting on the gas setting valve.

Air

- Move the adjustable profile 7) of the cam by gradually acting on the screws 9).

3.2 - Minimal output setting

Gas

- Disjoint the cam with adjustable profile 6) by means of the button 5).
- Turn manually anticlockwise the cam till to reach the position of 30°.
- Lock it again and measure the gas rate.

If a different minimal output is desired, set free the cam with adjustable profile and turn it anticlockwise; for a higher output turn it clockwise. When the minimal value is satisfying, set on the cam 3) the opening value signed on the pointer 4).

Air

- Vary the profile of the cam 7) by gradually acting on the screws 9).

Be careful to not modify the part of profile controlling the air shutter at the maximum output, previously set.

3.3 - Intermediate outputs setting

Gas

No setting is required.

Air

It is carry out by acting on the screws 9) of the cam profile, being careful to not move those for the minimum and maximum outputs.

When the combustion setting is ended re-connect the electrical wiring of the servomotor by plugging the connector 5) (page 1); then lock the screws 9) by means of the cross-screws 8).

4 - RATIO BETWEEN THE MINIMUM AND MAXIMUM OUTPUT (References on drawings at page 9)

For a better explanation we suppose to have a burner with an adjustable output between the range 25 - 100. The ratio between 1 : 4 (25 - 100) and 1 : 3 (25 - 75); our burners leave the factory set for these ratio.

If the ratio should be reduced at 1 : 2 (25 - 50 or 50 - 100) it is advisable to re-adjust the tension rods for the air and gas and the controlling sector of the gas throttle valve.

4.1 - Control of the gas throttle valve

The tension rod 11) moving the control sector of the throttle valve is positioned - by the factory - on the hole marked 90° (90° is the moving angle of the throttle valve when the cam with the adjustable profile 6) covers the complete angle of 130°).

When the ratio between the minimum and maximum output is approximately 1 : 2, the tension rod shall be positioned on the hole marked 60° (60° is the moving angle of the throttle valve when the cam covers 130°).

If the ratio 1 : 2 is in the lower outputs range (25 - 50) the change from 90° to 60° of the tension rod will be sufficient. Should this ratio be in higher range (50 - 100) in this case, further to position the tension rod on 60° it shall be shortened.

Proceed as follows:

- Disjoint the articulation from the control sector.
- Screw down the tension rod on the extension.
- Re-assemble the articulation on the control sector.

In this way the gas throttle valve - servomotor at 0° - is partially open.

The shortening of the tension rod shall permit the gas flow without setting the 3rd cam of the servomotor too forward, because in this way the turn of the cam with adjustable profile would be limited.

Throttle valve control sector

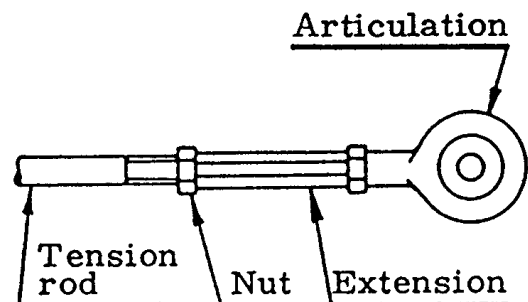
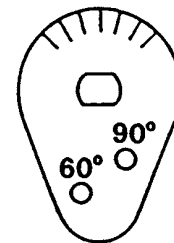

4.2 - Control of the air damper

The length of the tension rod 13) adjusting the air damper can be varied too.

If the air damper is moving, during the operation, into a reduced angle (ratio 1 : 2 lower outputs range) it is necessary to extend the tension rod.

In this way the cam profile is not too much bent.

When the burner is off proceed in this way:

- Disjoint the articulation 14) of the tension rod 13) from the lever 15).
- Extend the tension rod.
- Manually position the servomotor on 0°.
- Join the tension rod to the lever.
- Move the cam profile till the pointer placed on the air damper shaft is at 0°.

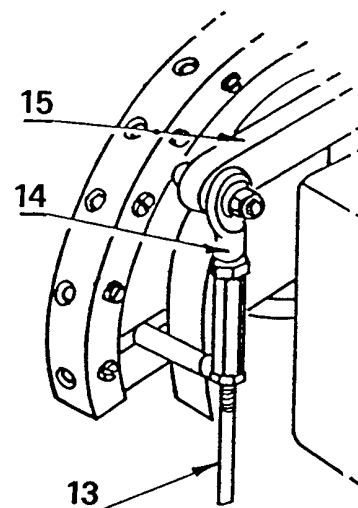

COMBUSTION CHECKS

CO₂

It is advisable to not exceed 10% of CO₂ (gas with calorific value of 8600 kcal/m³), in order to avoid the risk that small changes of the adjustments due, for instance, at draught variation, may cause combustion with insufficient air and consequently formation of CO.

CO

For safety reason the value of 0.1% (one thousand p.p.m.) must not be exceeded.

IONIZATION CURRENT

The minimum current necessary for the control box operation is 6 μ A.

The burner normally supplies a higher current value, so that no check is needed.

However, if a measurement of the ionization current is required, it is necessary to disconnect the probe lead and insert a d.c. microamperometer.

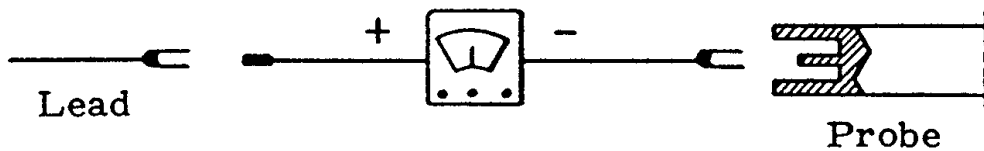

Motor lock-out

This is caused by the thermal protector relay, in case of overloading, or by the lacking of the phase. To clear, pushdown the appropriate knob, after having removed the protective cover.

BURNER START-UP

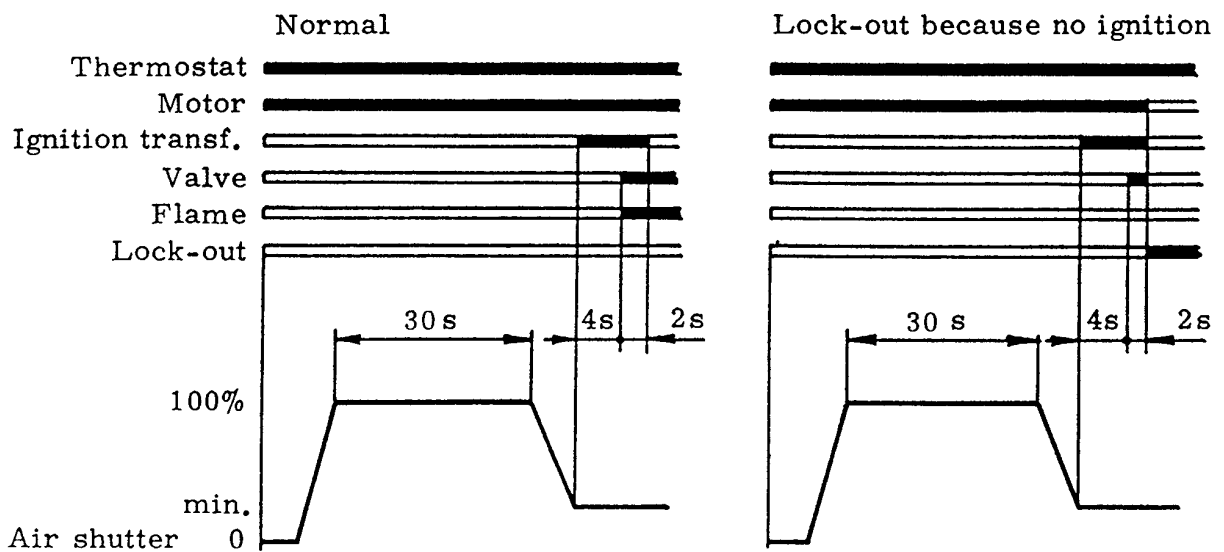

If during operation the flame shut off, lock-out occurs within 1 sec.

OPERATION TROUBLES AND THEIR CAUSES

The symbol, visible on the reading disc of the pointer, shows the kind of problem.

◆ The control box does not start at the thermostats closing, because of:

- lack of gas;
- the gas pressure switch does not close the contact: bad set;
- the air pressure switch changed over in operation position;
- the control box fuse is broken;
- the servomotor does not totally change over the closing circuit in being between the terminals 11 and 8 of the control box.

▲ Stop at the start-up, because of:

- the servomotor does not change over the max. opening circuit in being between the terminals 9 and 8 of the control box.

P Lock-out

The air pressure switch does not change over, because of:

- defective contact;
- insufficient pressure of the air.

■ Lock-out

Unperfect operation of the flame detecting circuit, because of:

- probe to earth;
- defective internal amplifier.

▼ Stop during pre-purge phase, because of:

the servomotor does not change over the minimal opening circuit in being between the terminals 10 and 8 of the control box.

1 Lock-out due to flame signal lack; if:

- the ionisation probe is not inside of the flame;
- the probe connection to the control box is disconnected;
- the ionization current is insufficient (min. 6 μ A).

■ Lock-out during operation due to:

- flame signal lack;
- no air pressure.

NOTICE

- If lock-out occurs between the start-up and pre-ignition phase without that a symbol comes out, the cause is the flame simulation.
- If the burner repeats continuously the start-up cycle without lock-out occurring, this is due to the "oscillation" of the gas pressure switch caused by a setting very near to the gas network pressure, therefore the pressure decreasing at the burner start-up is sufficient to actuate the gas pressure switch causing a new start-up.

RIELLO

RIELLO S.p.A.
I-37045 Legnago (VR)
Tel.: +39.0442.630111
[http:// www.riello.it](http://www.riello.it)
[http:// www.rielloburners.com](http://www.rielloburners.com)