

Gas burner

MODEL	TYPE
GAS 4	516 T80

TECHNICAL FEATURES

Thermal output	180 - 470 kW 154.800 - 404.200 kcal/h
Fuel	Natural gas Pci 8 - 10 kWh/m ³ = 7000 - 8600 kcal/m ³
Minimum gas pressure	For maximum output 9.8 mbar are needed measured at the coupling with nil pressure in the combustion chamber and gas with calorific value of 8600 kcal/m ³
Maximum gas pressure	150 mbar
Electrical supply	Three phase 380 V + 10% - 10% ~ 60Hz with neutral
Motor	1.5 A / 380 V
Ignition transformer	Primary: 1.8A / 220V - Secondary: 1 x 8 kV - 30 mA
Absorbed electrical power	0.6 kW

- 1 – Air shutter control
- 2 – Air shutter lock-nut
- 3 – Control box re-set button
- 4 – Fair leads
- 5 – Wiring terminal block
- 6 – Re-set push-button of the motor overload relay
- 7 – Air pressure switch
- 8– Gas pressure test-point

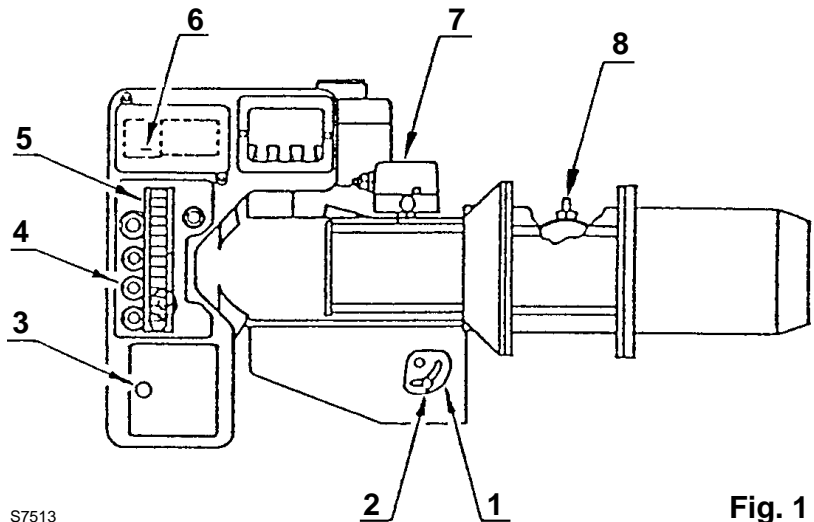

S7513

Fig. 1

DIMENSIONS

Boiler front-plate drilling

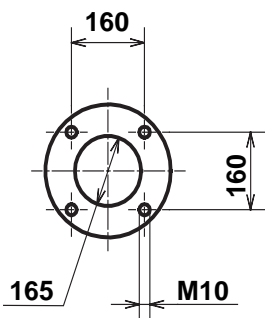

D1785

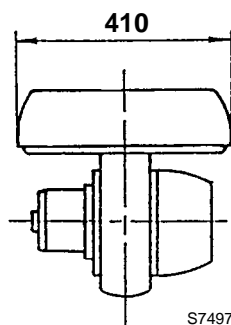

S7497

Burner

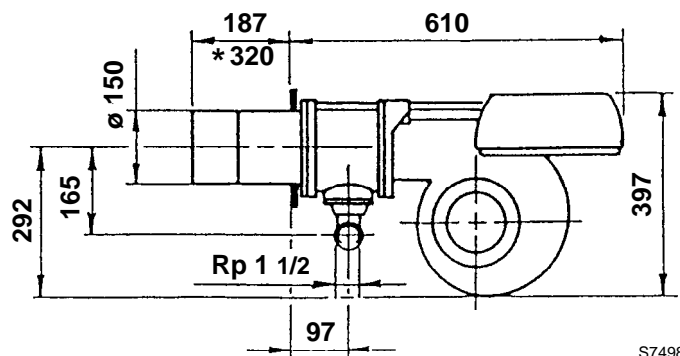

S7498

*Length available with special blast tube to be separately required.

EQUIPMENT

Quantity	Burner accessories
1	Flange
1	Gasket
8	Screws
1	Flange gasket

FIXING TO THE BOILER

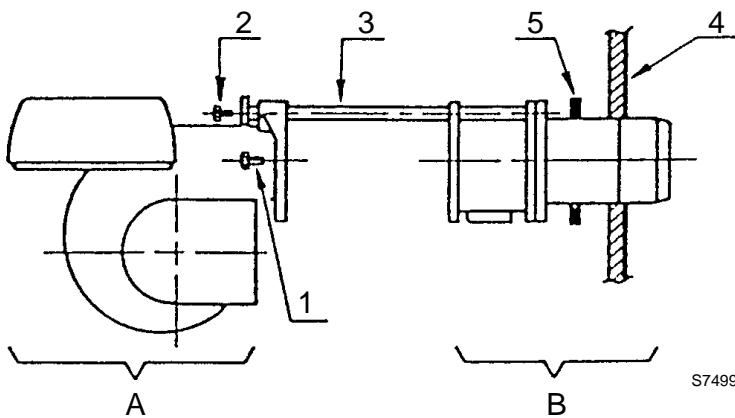

Separate the combustion head from the burner body by loosening the screws 1) and 2) and with drawing the group A) from the holding bars 3). Fix the group B) to the boiler front plate 4) using the gasket 5) provided as accessory.

GAS SUPPLY

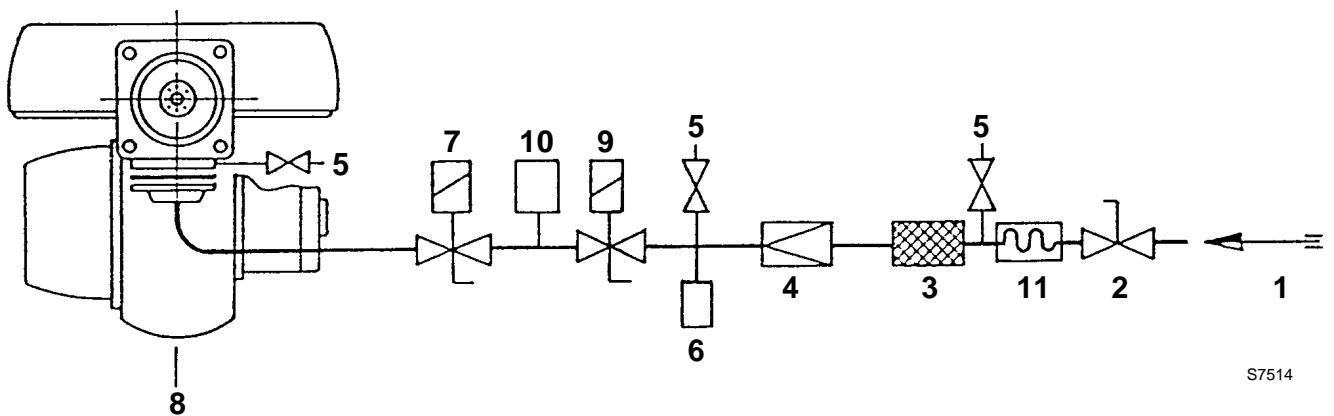

- 1 - Gas pipe line
- 2 - Cock valve
- 3 - Filter
- 4 - Pressure stabilizer
- 5 - Pressure test-point
- 6 - Minimal gas pressure switch

- 7 - Gas shut off valve
- 8 - Burner
- 9 - Gas safety shut off valve
- 10 - Gas leak control device
- 11 - Isolator joint

WORKING RANGE

COMBUSTION CHAMBER PRESSURE - MAXIMUM OUTPUT

(in compliance with DIN 4788)

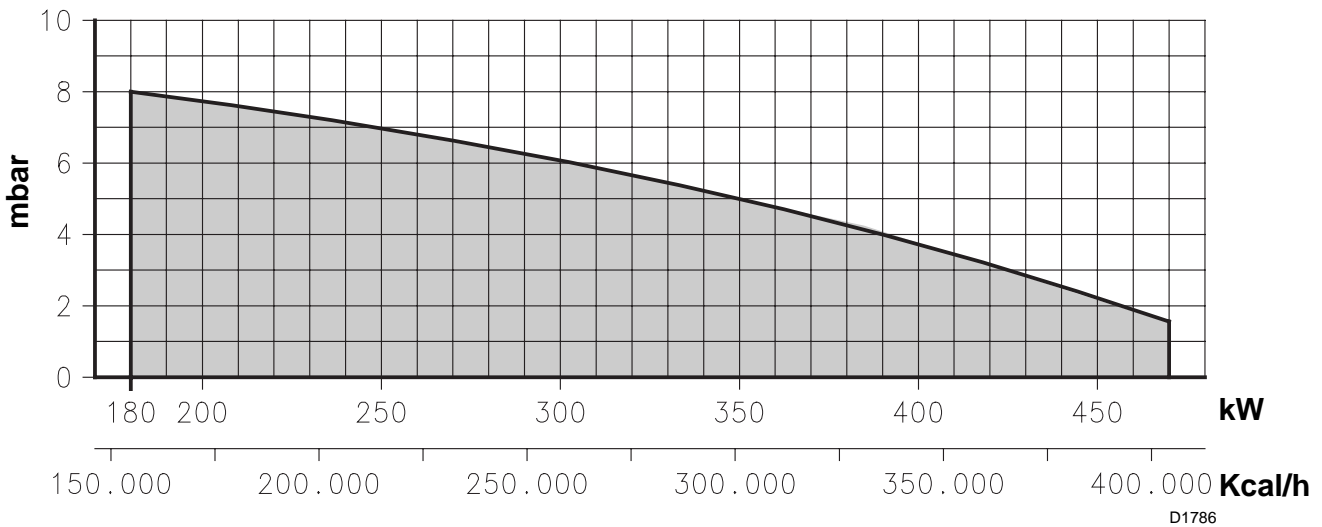

MINIMUM GAS PRESSURE - OUTPUT

Pressure: detected at the pressure test-point 7) (fig. 1) with nil mbar into the combustion chamber. Should the combustion chamber be pressurized, the pressure necessary will be that of the graph plus the pressurization value.

Example: to obtain 350 kW it is necessary a gas pressure of 7 mbar and the combustion head set as indicated at page 7.

If the combustion chamber is pressurized at 2 mbar, the pressure detected at the test-point 7) is: $7 + 2 = 9$ mbar.

If this value is too high, for very low gas pipework pressures, the gas gear 6) (page 7) could be more open.

Do not decrease the pressure at the coupling under the values shown in the diagram.

Output: the maximum value is obtainable with gas Pci 8600 kcal/m³.

CORRELATION BETWEEN GAS PRESSURE AND BURNER OUTPUT

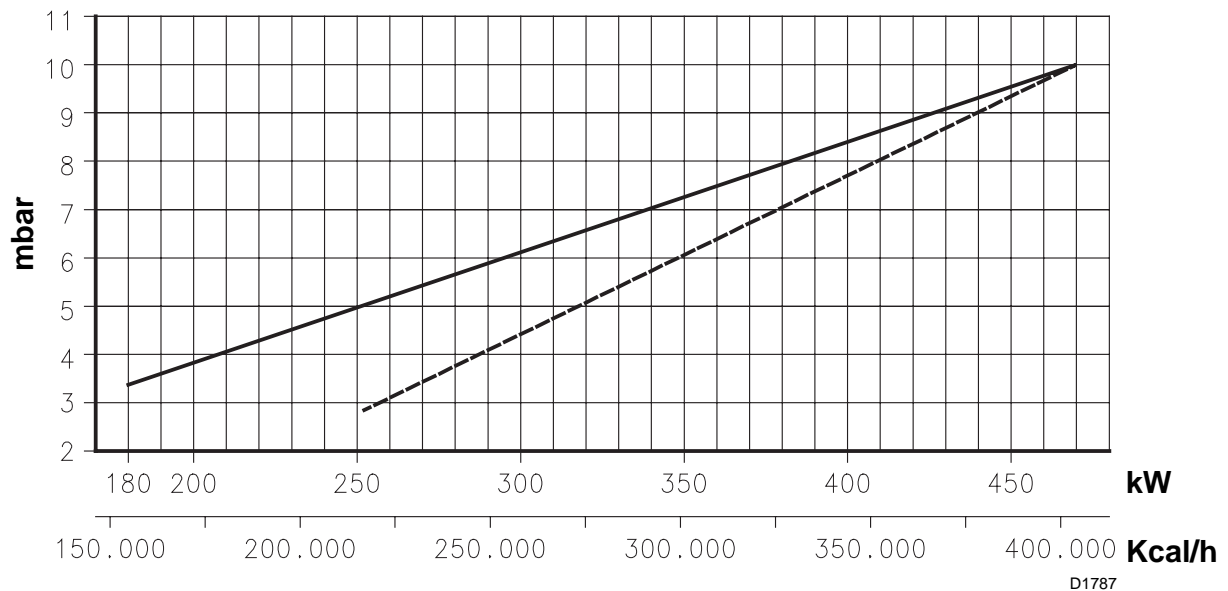

BURNER ELECTRICAL WIRING

(carried out in the factory)

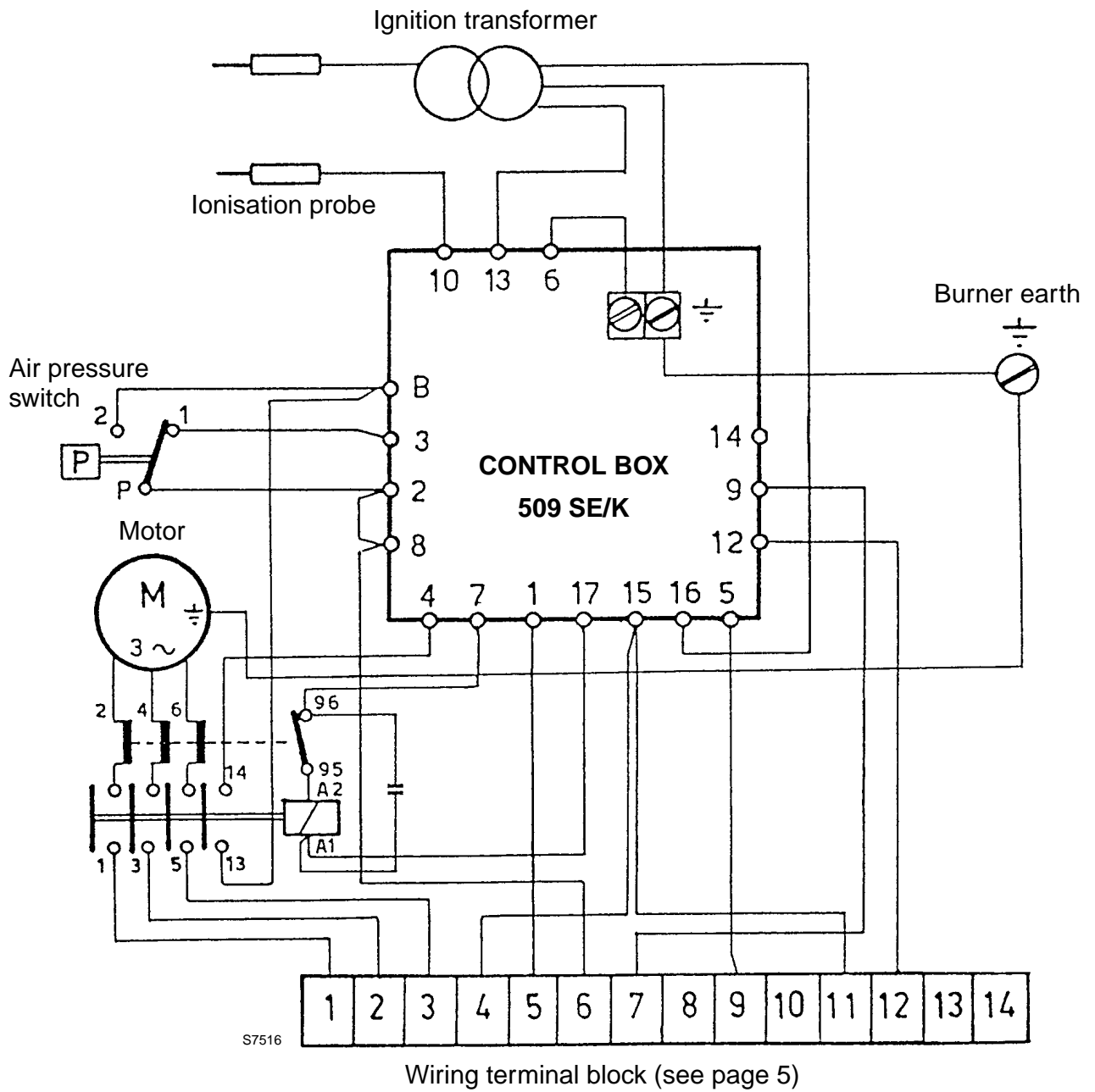

ELECTRICAL CONNECTIONS TO THE WIRING TERMINAL BLOCK

(to be carried out by the installer)

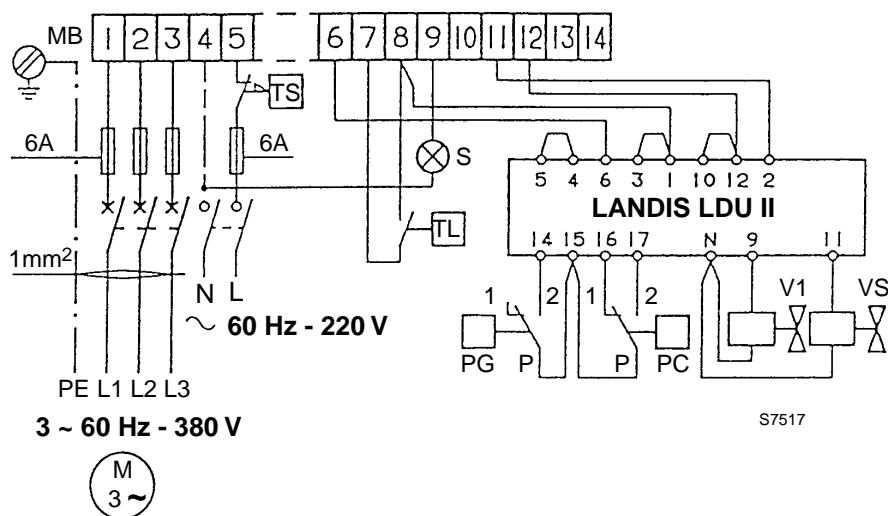

KEY:

- MB** : Burner terminal strip.
- TS** : Safety remote control system.
- TL** : Limit control system.
- S** : Remote lock signal.
- PG** : Min. gas pressure switch.
- PC** : Check pressure switch.
- V1** : Gas shut off valve.
- VS** : Gas safety shut off valve.

Notice

- Leads minimal section 1 mm².
- The electric wiring carried out by the installer must be in compliance with the rules in force in the Country.

FIXING OF THE ELECTRICAL WIRES

All the electrical wires, which are to be connected to the terminal block 5) (fig. 1) shall pass through the fair leads 4) (fig. 1) as for this scheme.

- | | | |
|---|-------------------------|---|
| 1 | - Single phase supply | : fair lead Pg 13.5 |
| 2 | - Adjustment thermostat | : fair lead Pg 13.5 |
| 3 | - Safety thermostat | : fair lead Pg 13.5 |
| 4 | - Gas train | : fair lead Pg 13.5,
sheath \varnothing 13 |

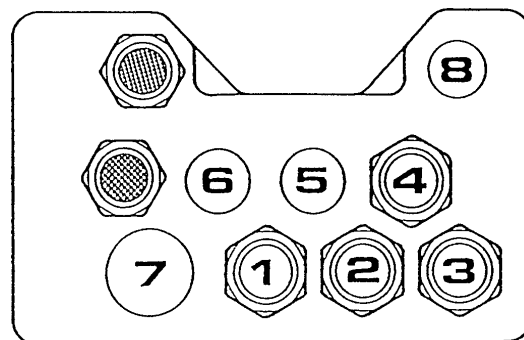

S7505

5 / 6 / 7 / 8 - Pre-sheared holes

Further prospective signals or controls can be connected to the burner wiring terminal board by removing the metal weldnuts from the pre-sheared holes and inserting a common fair lead for the passage and the clamping of the leads.

NOTES

- Do not exchange the neutral wire with the phase (avoid the plug-pin connection).
- Carry out a safe earth connection.
- Check the stop of the burner, by opening the boiler thermostat and the burner lock-out, by disconnecting the lead from the flame probe.

WARNING

When closing the burner on its slide-bars, pull towards the outside the high voltage cable and the cable of the flame detection probe, till to little tension.

BURNER START-UP CYCLE

Air-purge: loosen the screw placed on the minimal gas pressure switch mounted on the gas train.

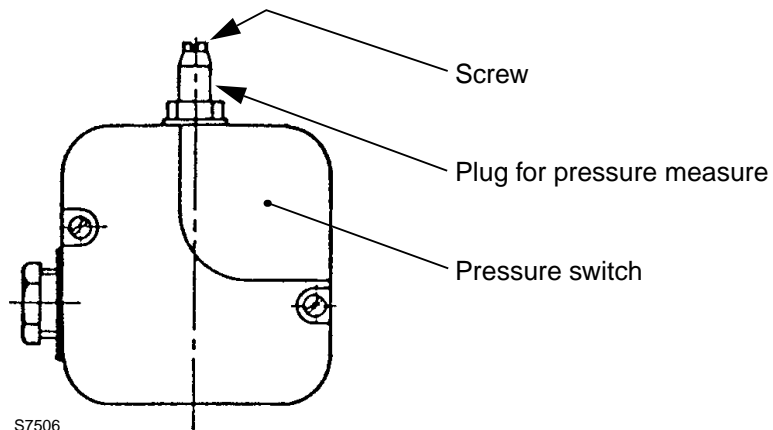

AIR PRESSURE SWITCH 7) (fig.1)

The air pressure switch setting shall be carried out after having set all other adjustment of the burner and the air pressure switch shall be at its lowest set-point.

When the burner is operating, increase the adjustment pressure by turning - slowly - clockwise the knob till reaching the burner lock-out.

Thereafter, turn the knob anticlockwise for 1 mbar and repeat the burner start-up for checking the regularity: if lock-out intervenes turn the knob anticlockwise for 0.5 mbar.

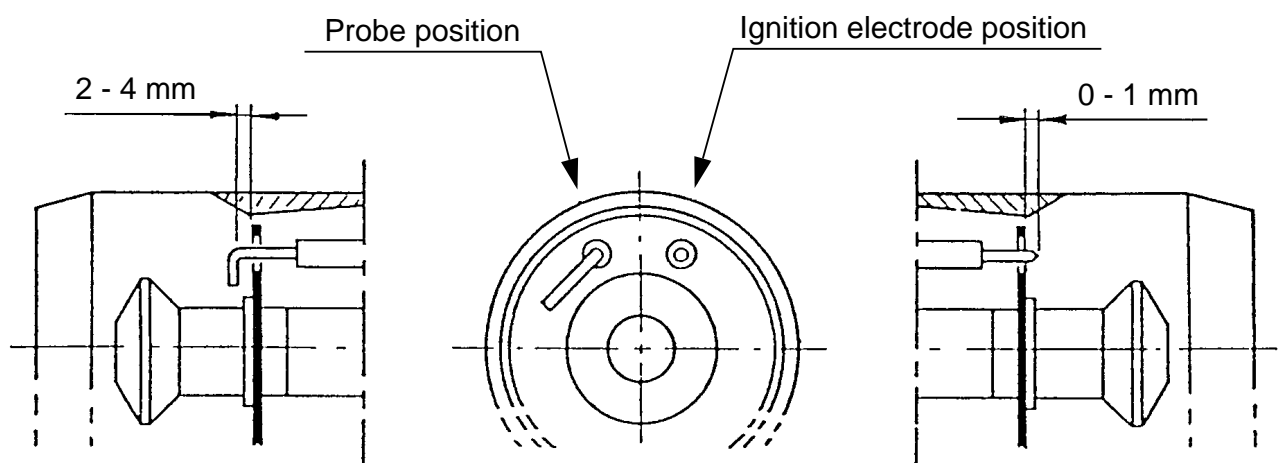
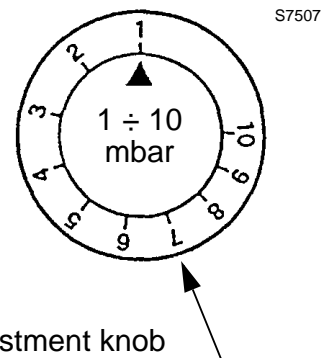

CAUTION:

do not turn the ionization probe, maintain the drawing position; should it be close to the ignition electrode, damage may occur to the control box amplifier.

COMBUSTION HEAD ADJUSTMENT

Two separate adjustments have to be made: air and gas.

These adjustments can be carried out when the burner is still open, during the installation (see page 2 - Fixing to the boiler).

Air setting

Loosen the two screws 1) and move the internal part of the combustion head 2) so that its rear edge 3) is coincident with the desired set-point on the plate 4). Tighten the screws 1).

Gas setting

Loosen the screw 5), move the ring 6) so that the pointer 7) is coincident with the desired set-point 8). Tighten the screw 5).

Attention:

the set-point number is the same for air and gas setting and is given by the following diagram.

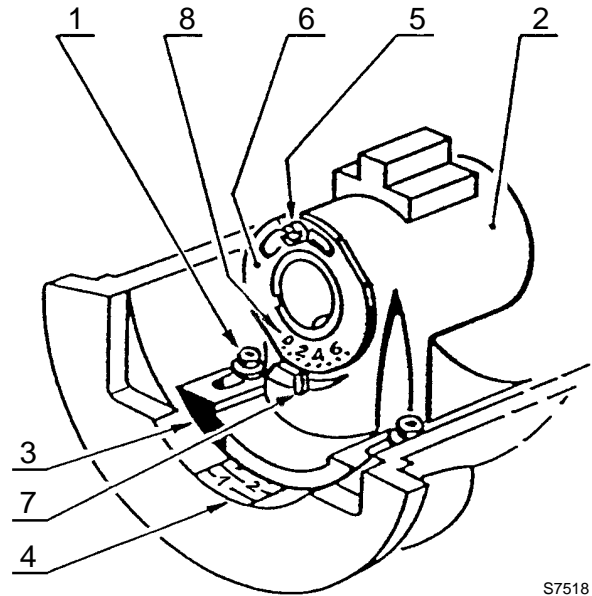

S7518

Example:

the burner is installed on a boiler of 270 kW, assuming an efficiency of 90% the burner output should be 300 kW.

From the diagram it can be seen that the air and gas settings for this rating should be no. 3.

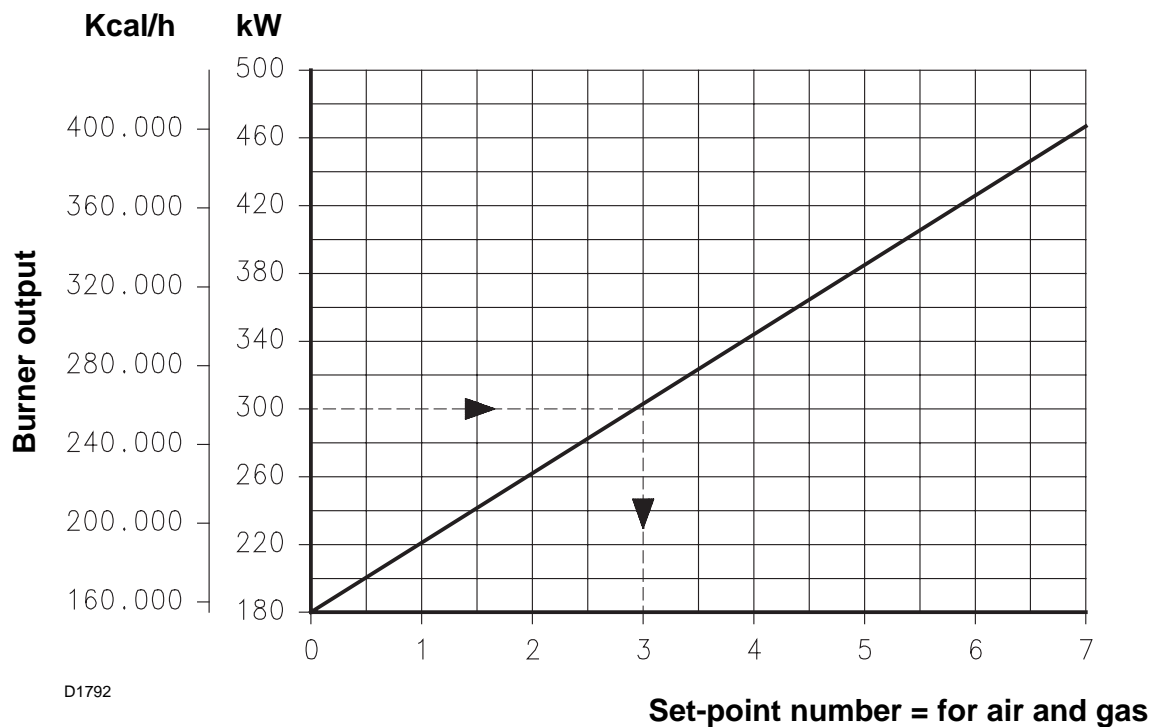

D1792

COMBUSTION CHECKS

CO₂

It is advisable to not exceed 10% of CO₂ (gas with calorific value of 8600 kcal/m³), in order to avoid the risk that small changes of the adjustments due, for instance, at draught variation, may cause combustion with insufficient air and consequently formation of CO.

CO

For safety reason the value of 0.1% (one thousand p.p.m.) must not be exceeded.

IONIZATION CURRENT

The minimum current necessary for the control box operation is 3 µA.

The burner normally supplies a higher current value, so that no check is needed.

However, if a measurement of the ionization current is required, it is necessary to disconnect the probe lead and insert a d.c. microammeter.

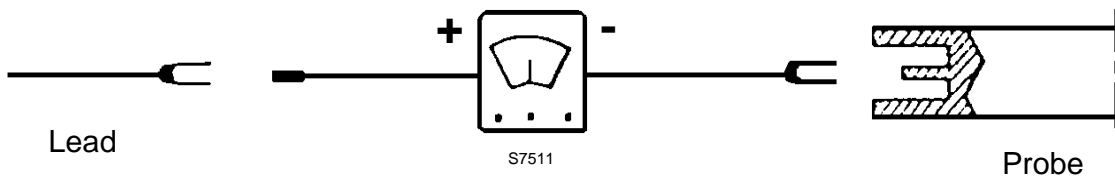

MOTOR LOCK-OUT

This is caused by the thermal protector relay, in case of overloading, or by the lacking of the phase. To clear, pushdown the appropriate knob, after having removed the protective cover

BURNER START-UP

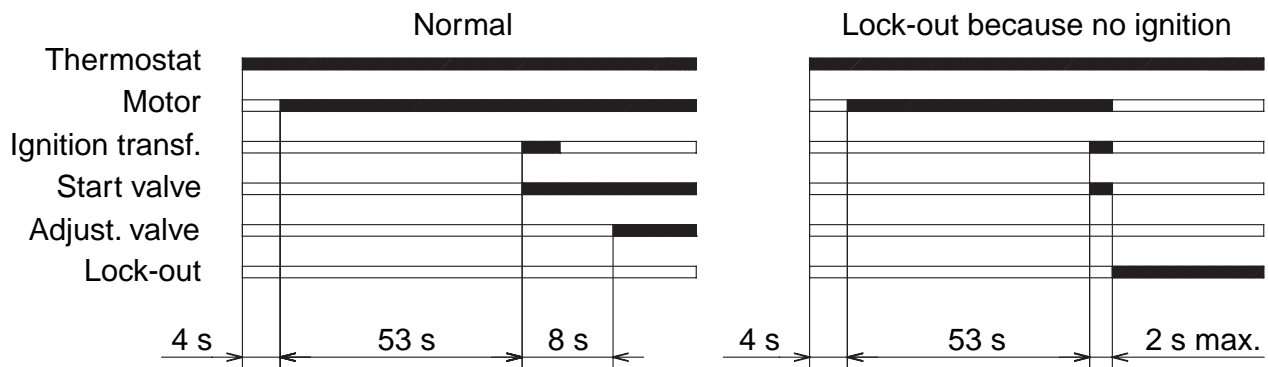

D1798

If during operation the flame shuts off, lock-out occurs within 1 sec.

BURNER STARTING DIFFICULTIES AND THEIR CAUSES

DIFFICULTIES	CAUSES
The burner goes through the purge period normally, the flame ignites, but the burner goes to lock-out, within two seconds after the ignition if:	The ionization probe is earthed or not in contact with the flame, or its wiring to the control box is broken, or there is a fault on its insulation to earth.
	The ionization current is weak (lower than 3 μ A).
The burner goes to lock-out, after the purge period, because the flame does not ignite; the causes may be:	The valve is passing too little gas (low pressure in the gas pipework).
	The valve is defective.
	The pipe has not been purged from the air.
	The ignition arc is irregular or has failed.
The burner does not pass through the pre-purge period and the control box goes to lock-out:	The air pressure switch does not change over: it has failed or the air pressure is too low (combustion head bad set).
	Flame simulation exists (or the flame really lights).
The burner does not start at the thermostat closing, because of:	Gas is not supplied.
	The gas pressure switch does not close: incorrectly adjusted.
	The air pressure switch is changed over to the operational position.
	The fuse of the control box is broken.
The burner repeats the start-up cycle without occurring the lock-out:	<p>This particular trouble is caused by the gas pipework pressure that is very close to the value of the gas pressure switch setting, owing to the sudden pressure decrease the valve opens and actuates - only temporarily - the opening of the pressure switch, thereafter the valve closes, the motor stops and the pressure increases again; the pressure switch closes and the start-up cycle is repeated and so forth.</p> <p>To prevent this trouble, setting the gas pressure switch at a lower value.</p>

OPERATING FAULTS

Lock-out may occur, because of:

- flame failure;
- ionization probe earthed;
- air pressure switch open.

Shut-off may depend on the gas pressure switch opening.

RIELLO

RIELLO S.p.A.
Via degli Alpini 1
I - 37045 Legnago (VR)
Tel.: +39.0442.630111 Fax: +39.0442.630375
[http:// www.rielloburners.com](http://www.rielloburners.com)