

## Kerosene and gas oil burner

One stage operation



CODE	BOULTER CODE	MODEL	TYPE
3748962	8-716-111-556	COH 280	490 T51



**Original instructions**

<b>1</b>	<b>Declaration</b>	<b>3</b>
<b>2</b>	<b>Information and general warnings</b>	<b>4</b>
2.1	Information about the instruction manual	4
2.1.1	Introduction	4
2.1.2	General dangers	4
2.1.3	Other symbols	4
2.1.4	Delivery of the system and the instruction manual	5
2.2	Guarantee and responsibility	5
2.3	Guidance for the use of bio fuel blends up to 10% where gas oil use is permitted by the appliance Manufacturer	6
2.3.1	Information and general instructions	6
2.3.2	Product Disclaimer Statement	6
<b>3</b>	<b>Safety and prevention</b>	<b>7</b>
3.1	Introduction	7
3.2	Safety warnings	7
3.3	Basic safety rules	7
3.4	Personnel training	7
<b>4</b>	<b>Technical description of the burner</b>	<b>8</b>
4.1	Technical data	8
4.2	Burner description	8
4.3	Burner equipment	8
4.4	Burner dimensions	9
4.5	Firing rate	9
<b>5</b>	<b>Installation</b>	<b>10</b>
5.1	Notes on safety for the installation	10
5.2	Handling	10
5.3	Preliminary checks	10
5.4	Installer/Service notes for the use of Gas oil with Bio blends up to 10%	11
5.5	Working position	11
5.6	Boiler fixing	12
5.7	Mounting the burner	13
<b>6</b>	<b>Hydraulic systems</b>	<b>14</b>
6.1	Fuel supply	14
6.1.1	Pump	14
6.2	One pipe system	15
6.2.1	Priming pump	15
6.3	Two pipe system	16
6.3.1	Priming pump	16
<b>7</b>	<b>Electrical system</b>	<b>17</b>
7.1	Notes on safety for the electrical wiring	17
7.2	Electrical wiring	18
7.2.1	Control box	18
<b>8</b>	<b>Start-up, calibration and operation of the burner</b>	<b>19</b>
8.1	Notes on safety for the first start-up	19
8.2	Combustion adjustment	19
8.3	Nozzles installation	19
8.3.1	Nozzles recommended	20
8.4	Pump pressure	20
8.5	Air damper adjustment	20
8.6	Combustion head adjustment	20
8.7	Diffuser disc unit and electrodes setting	20

8.8	Burner start-up cycle .....	21
<b>9</b>	<b>Maintenance .....</b>	<b>22</b>
9.1	Notes on safety for the maintenance.....	22
9.2	Maintenance programme .....	22
9.2.1	Maintenance frequency .....	22
9.2.2	Checking and cleaning .....	22
9.2.3	Safety components.....	23
9.3	Maintenance position .....	23
<b>10</b>	<b>Faults - Probable causes - Solutions .....</b>	<b>24</b>

**1 Declaration****Declaration of Conformity in accordance with ISO / IEC 17050-1**

These products are in compliance with the following Technical Standards:

- EN 12100
- EN 267

According to the European Directives:

MD	2006/42/EC	Machine Directive
LVD	2014/35/EU	Low Voltage Directive
EMC	2014/30/EU	Electromagnetic Compatibility

---

**The quality is guaranteed by a quality and management system certified in accordance with ISO 9001:2015.**

**2 Information and general warnings**

**2.1 Information about the instruction manual**

**2.1.1 Introduction**

The instruction manual supplied with the burner:

- is an integral and essential part of the product and must not be separated from it; it must therefore be kept carefully for any necessary consultation and must accompany the burner even if it is transferred to another owner or user, or to another system. If the manual is lost or damaged, another copy must be requested from the Technical Assistance Service of the area;
- is designed for use by qualified personnel;
- offers important indications and instructions relating to the installation safety, start-up, use and maintenance of the burner.

**Symbols used in the manual**

In some parts of the manual you will see triangular DANGER signs. Pay great attention to these, as they indicate a situation of potential danger.

**2.1.2 General dangers**

The **dangers** can be of **3 levels**, as indicated below.



Maximum danger level!  
This symbol indicates operations which, if not carried out correctly, cause serious injury, death or long-term health risks.



This symbol indicates operations which, if not carried out correctly, may cause serious injury, death or long-term health risks.



This symbol indicates operations which, if not carried out correctly, may cause damage to the machine and/or injury to people.

**2.1.3 Other symbols**



**DANGER: LIVE COMPONENTS**  
This symbol indicates operations which, if not carried out correctly, lead to electric shocks with lethal consequences.



**DANGER: FLAMMABLE MATERIAL**  
This symbol indicates the presence of flammable materials.



**DANGER: BURNING**  
This symbol indicates the risks of burns due to high temperatures.



**DANGER: CRUSHING OF LIMBS**  
This symbol indicates the presence of moving parts: danger of crushing of limbs.



**WARNING: MOVING PARTS**  
This symbol indicates that you must keep limbs away from moving mechanical parts; danger of crushing.



**DANGER: EXPLOSION**  
This symbol signals places where an explosive atmosphere may be present. An explosive atmosphere is defined as a mixture - under atmospheric conditions - of air and flammable substances in the form of gases, vapours, mist or dust in which, after ignition has occurred, combustion spreads to the entire unburned mixture.



**PERSONAL PROTECTION EQUIPMENT**  
These symbols indicate the equipment that must be worn and kept by the operator for protection against threats against safety and/or health while at work.



**OBLIGATION TO ASSEMBLE THE HOOD AND ALL THE SAFETY AND PROTECTION DEVICES**  
This symbol signals the obligation to reassemble the hood and all the safety and protection devices of the burner after any maintenance, cleaning or checking operations.



**ENVIRONMENTAL PROTECTION**  
This symbol gives indications for the use of the machine with respect for the environment.



**IMPORTANT INFORMATION**  
This symbol indicates important information that you must bear in mind.

- This symbol indicates a list.

**Abbreviations used**

Ch.	Chapter
Fig.	Figure
Page	Page
Sec.	Section
Tab.	Table

**2.1.4 Delivery of the system and the instruction manual**

When the system is delivered, it is important that:

- the instruction manual is delivered to the user by the system manufacturer, with the recommendation to keep it in the room where the heat generator is to be installed.
- The instruction manual shows:
  - the serial number of the burner;

.....

- the address and telephone number of the nearest Assistance Centre

.....  
 .....  
 .....

- The system supplier must carefully inform the user about:
  - the use of the system;
  - any further tests that may be required before activating the system;
  - maintenance, and the need to have the system checked at least once a year by a representative of the manufacturer or another specialised technician.
 To ensure a periodic check, the manufacturer recommends the drawing up of a Maintenance Contract.

**2.2 Guarantee and responsibility**

The manufacturer guarantees its new products from the installation date, in accordance with the regulations in force and/or the sales contract. At the moment of the first start-up, check that the burner is integral and complete.



**WARNING**

Failure to observe the information given in this manual, operating negligence, incorrect installation and carrying out of non authorised modifications will result in the annulment by the manufacturer of the guarantee that it supplies with the burner.

In particular, the rights to the guarantee and the responsibility will no longer be valid, in the event of damage to things or injury to people, if such damage/injury was due to any of the following causes:

- incorrect installation, start-up, use and maintenance of the burner;
- improper, incorrect or unreasonable use of the burner;
- intervention of unqualified personnel;
- carrying out of unauthorised modifications on the equipment;
- use of the burner with safety devices that are faulty, incorrectly applied and/or not working;
- installation of untested supplementary components on the burner;
- powering of the burner with unsuitable fuels;
- faults in the fuel supply system;
- continuation of use of the burner when a fault has occurred;
- repairs and/or overhauls incorrectly carried out;
- modification of the combustion chamber with inserts that prevent the regular development of the structurally established flame;
- insufficient and inappropriate surveillance and care of those burner components most likely to be subject to wear and tear;
- the use of non-original components, including spare parts, kits, accessories and optional;
- force majeure.

**The manufacturer furthermore declines any and every responsibility for the failure to observe the contents of this manual.**

Riello warranty is subject to correct burner, appliance and application matching, and set up in line with Riello's instructions and guidelines. All components within the hydraulic circuit suitable for bio fuel use and supplied by Riello will be identified as Bio compatible. No warranty is given in relation to the use of components which are not so identified with bio fuel blends. If in any doubt please contact Riello for further advice.

If any Riello burners are used with fuel with a bio content >10% then the components within the hydraulic circuit maybe affected and are not covered under warranty.

The hydraulic circuit consists of:

- Pump
- Hydraulic ram (where applicable)
- Valve block
- Flexible oil lines (considered as a consumable component)

- 1 Irrespective of any warranty given by Riello in relation to normal use and manufacturing defects, when fuels not meeting the relevant standards are used, or where fuel storage issues have not been addressed correctly, or the equipment used is not compatible, if failures occur which are directly or indirectly attributed to such issues and/or to the non-observance of this guidance, then no warranty or liability is implied or accepted by Riello.
- 2 Riello have carefully chosen the specification of the bio compatible components including the flexible oil lines to protect the pump, safety value and nozzle. The Riello warranty is dependent upon the use of Riello genuine components including the oil lines, being used.
- 3 Riello warranty does not cover defects arising from incorrect commissioning or servicing by non Riello employed service engineers, and any issues impacting the burner arising from external site related issues.

### 2.3 Guidance for the use of bio fuel blends up to 10% where gas oil use is permitted by the appliance Manufacturer

#### Background

With increasing focus on renewable and sustainable energy requirements, Bio fuel usage is set to increase. Riello is committed to promoting energy conservation and the use of renewable energy from sustainable resources including liquid bio fuels, however there are some technical aspects that must be considered at the planning stage of using such fuels to reduce the potential for equipment failure or the risks of fuel leakage.

Liquid Bio fuel is a generic description used for oil that can come from numerous feed stocks including recycled cooking oils. These types of oils have to be considered and treated differently from standard mineral or fossil fuels, as they are generally more acidic, hygroscopic and less stable.

Due to this, a holistic approach is needed from the specification of the liquid Bio fuel, the storage of the fuel, its oil supply line and ancillary equipment, and very importantly the oil filtration and the burner itself. The specification for FAME (Fatty Acids Methyl Ester) liquid Bio fuel is critical to reliable equipment operation.

It is a minimum requirement that the fuel blend (up to 10% Bio) is obtained with gas-oil in accordance with the relevant EN standards, regional regulations and FAME in accordance with EN 14214. It is also important that the fuel blends meet the requirements related to operational environment conditions within the relevant EN standards.

When choosing your Riello oil products where you know Bio fuels will be in use, please make sure that a Bio compatible burner and/or components have been supplied. If an existing burner is to be used with a liquid Bio fuel then a kit may be required to make it compatible and the guidance notes enclosed concerning oil storage and filtration must be adhered to. The end user is responsible for the thorough verification of the potential risks associated with the introduction of a bio fuel blend and the suitability of the appliances and installation applicable.

Irrespective of any warranty given by Riello in relation to normal use and manufacturing defects, when fuels not meeting the relevant standards are used, or where fuel storage issues have not been addressed correctly, or the equipment used is not compatible, if failures occur which are directly or indirectly attributed to such issues and/or to the non-observance of this guidance, then no warranty or liability is implied or accepted by Riello.

#### 2.3.1 Information and general instructions

To ensure consistency, the supplier of the fuel must be able to demonstrate compliance with a recognised Quality Control and management system to ensure high standards are maintained within the storage, blending and delivery processes.

The installation oil storage tank and its ancillaries must also be prepared BEFORE liquid Bio fuel is introduced.

Checks and preparation should include:

- For new installations, make sure that all materials and seals in the oil storage and supply line to the burner are compatible with Bio fuels. For all installations, there must be a good quality bio compatible oil filter at the tank and then a secondary filter of 60 Microns protecting the burner from contamination.
- If an existing oil storage tank is to be used then in addition to the materials checks as detailed above, it will be essential that the tank is first inspected for condition and checked for water or other contamination. Riello strongly recommends that the tank is cleaned and oil filters replaced prior to Bio fuel delivery. If this is not completed then due to the hydroscopic nature of Bio fuel, it will effectively clean the tank,

absorb water present which in turn will result in equipment failure that is not covered by the manufacturer's warranty.

- Depending on the capacity of the oil storage tank and oil usage, fuels may remain static within the tank for some considerable time and so Riello recommends that the oil distributor is consulted regarding the use of additional Biocides within the fuel to prevent microbial growth from occurring within the tank. Riello suggests that fuel suppliers and or service companies are contacted for guidance on fuel filtration. Special attention should be applied to dual fuel applications where oil may be stored for long periods of time.
- The burner must be set according to the appliance application and commissioned checking that all combustion parameters are as recommended in the appliance technical manual.
- Riello recommends that the in line and burner oil pump filters are inspected and if required replaced at least every 4 months during burner use, before the burner start-up following a long period of discontinue operation and even more frequently where contamination has occurred. Particular attention is needed when inspecting and checking for fuel leakages from seals, gaskets and hoses.

#### 2.3.2 Product Disclaimer Statement

**CAREFULLY READ THE FOLLOWING DISCLAIMER. YOU ACCEPT AND AGREE TO BE BOUND BY THIS DISCLAIMER BY PURCHASING RIELLO BIO COMPATIBLE BURNERS AND/OR COMPONENTS.**

Although the information and recommendations (hereinafter "Information") in this guidance is presented in good faith, believed to be correct and has been carefully checked, Riello (and its subsidiaries) makes no representations or warranties as to the completeness or accuracy of the Information. Information is supplied upon the condition that the persons receiving same will make their own determination as to its suitability for their purposes prior to use. In no event will Riello (and its subsidiaries) be responsible for damages of any nature whatsoever resulting from the use of or reliance upon Information.

Other than set forth herein, Riello (and its subsidiaries) makes no additional warranties with respect to the bio compatible burner, either express or implied, including that of merchantability or fitness for a particular purpose or use.

In no event shall Riello (and its subsidiaries) be liable for any indirect, incidental, special or consequential damages including, without limitation, loss of profits, damages for loss of business profits, business interruption, loss of business information, loss of equipment, or other pecuniary loss or compensation for services whether or not it is advised of the possibility of such damages.

With the exception of injuries to persons, Riello's liability is limited to the customer's right to return defective/non-conforming products as provided by the relevant product warranty.



## 3 Safety and prevention

### 3.1 Introduction

The burners have been designed and built in compliance with current regulations and directives, applying the known technical rules of safety and envisaging all the potential danger situations.

It is necessary, however, to bear in mind that the imprudent and clumsy use of the equipment may lead to situations of death risk for the user or third parties, as well as the damaging of the burner or other items. Inattention, thoughtlessness and excessive confidence often cause accidents; the same applies to tiredness and sleepiness.

It is a good idea to remember the following:

- The burner must only be used as expressly described. Any other use should be considered improper and therefore dangerous.

In particular:

it can be applied to boilers operating with water, steam, diathermic oil, and to other uses expressly named by the manufacturer;

the type and pressure of the fuel, the voltage and frequency of the electrical power supply, the minimum and maximum deliveries for which the burner has been regulated, the pressurisation of the combustion chamber, the dimensions of the combustion chamber and the room temperature must all be within the values indicated in the instruction manual.

- Modification of the burner to alter its performance and destinations is not allowed.
- The burner must be used in exemplary technical safety conditions. Any disturbances that could compromise safety must be quickly eliminated.
- Opening or tampering with the burner components is not allowed, apart from the parts requiring maintenance.
- only those parts detailed as available as spare parts by the manufacturer can be replaced.

### 3.2 Safety warnings

The dimension of the boiler's combustion chamber must respond to specific values, in order to guarantee a combustion with the lowest polluting emissions rate.

The Technical Service Personnel will be glad to give you all the information for a correct matching of this burner to the boiler.

This burner must only be used for the application it was designed for.

The manufacturer accepts no liability within or without the contract for any damage caused to people, animals and property due to installation, adjustment and maintenance errors or to improper use.

### 3.3 Basic safety rules

- Children or inexperienced persons must not use the appliance.
- Under no circumstances must the intake grids, dissipation grids and ventilation vents in the installation room be covered up with cloths, paper or any other material.
- Unauthorised persons must not attempt to repair the appliance.
- It is dangerous to pull or twist the electric leads.
- Cleaning operations must not be performed if the appliance is not disconnected from the main power supply.
- Do not clean the burner or its parts with inflammable substances (e.g. petrol, alcohol, etc.). The cover must be cleaned with soapy water.
- Do not place anything on the burner.
- Do not block or reduce the size of the ventilation vents in the installation room.
- Do not leave containers and inflammable products or combustible materials in the installation room.

### 3.4 Personnel training

The user is the person, body or company that has acquired the machine and intends to use it for the specific purpose. He is responsible for the machine and for the training of the people working around it.

The user:

- undertakes to entrust the machine exclusively to suitably trained and qualified personnel;
- must take all the measures necessary to prevent unauthorised people gaining access to the machine;
- undertakes to inform his personnel in a suitable way about the application and observance of the safety instructions. With that aim, he undertakes to ensure that everyone knows the use and safety instructions for his own duties;
- must inform the manufacturer if faults or malfunctioning of the accident prevention systems are noticed, along with any presumed danger situation.
- Personnel must always use the personal protective equipment envisaged by legislation and follow the indications given in this manual.
- Personnel must observe all the danger and caution indications shown on the machine.
- Personnel must not carry out, on their own initiative, operations or interventions that are not within their province.
- Personnel must inform their superiors of every problem or dangerous situation that may arise.
- The assembly of parts of other makes, or any modifications, can alter the characteristics of the machine and hence compromise operating safety. The manufacturer therefore declines any and every responsibility for any damage that may be caused by the use of non-original parts.

**4 Technical description of the burner**

**4.1 Technical data**

MODEL	COH 280
Output – Thermal power (with air at 20 °C)	4 – 10 kg/h 47.45 – 120 kW
Fuel	Kerosene, viscosity 1.6 – 6 mm <sup>2</sup> /s at 20 °C (Hi = 11.97 kWh/kg) Gas oil, viscosity 4 – 6 mm <sup>2</sup> /s at 20 °C (Hi = 11.86 kWh/kg) Blends of gasoil and bio fuel (FAME in accordance with EN 14214) up to 10%
Electrical supply	Single phase, ~ 50Hz 230V ± 30%
Motor	Run current 1.3A – 2750 rpm – 288 rad/s
Capacitor	5 µF
Ignition transformer	Secondary 8 kV – 16 mA
Pump	Kerosene, maximum pressure 10 bar (145 psi) Gas oil, maximum pressure 15 bar (218 psi)
Absorbed electrical power	0.16 kW

Tab. A

**4.2 Burner description**

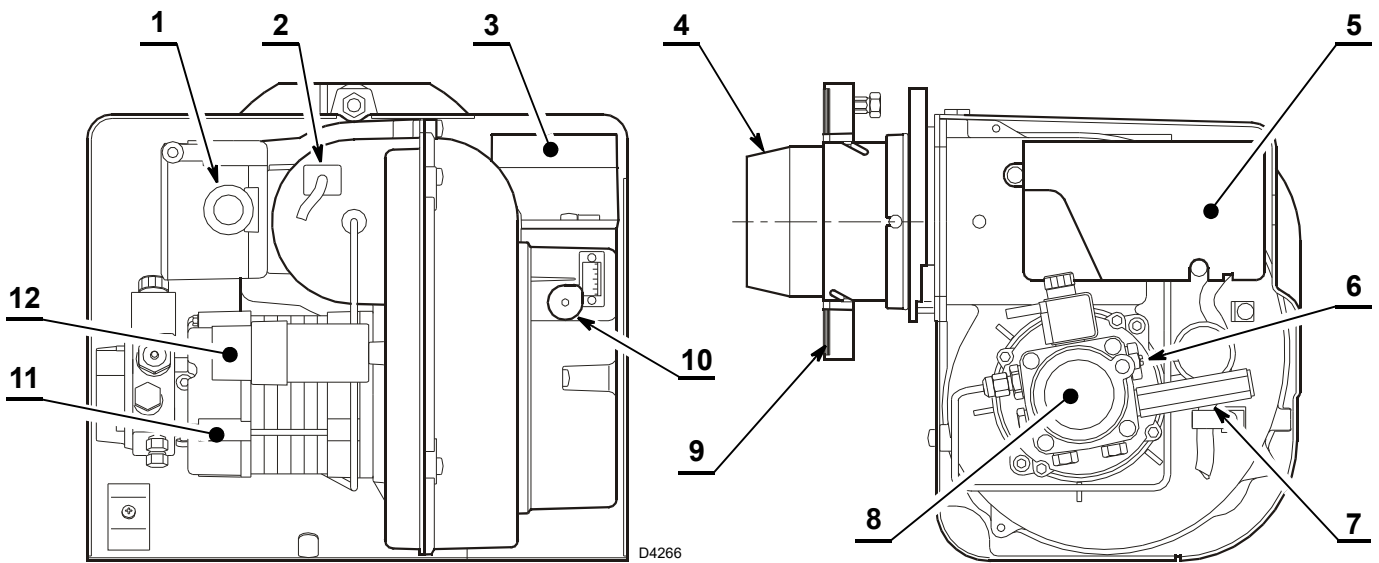

Fig. 1

- |                                   |                                |
|-----------------------------------|--------------------------------|
| 1 Reset button with lock-out lamp | 7 Pressure gauge port          |
| 2 Flame sensor                    | 8 Pump                         |
| 3 Snorkel (BF)                    | 9 Flange                       |
| 4 Blast tube                      | 10 Air damper adjustment screw |
| 5 Control-box                     | 11 Motor                       |
| 6 Pump pressure adjustment screw  | 12 Capacitor                   |

**4.3 Burner equipment**

- Hoses ..... No. 1  
Screw of by-pass pump (clipped on the pump)..... No. 1



The hoses supplied with this burner set for Kerosene use are not suitable for use with Gas oil containing a Bio blend.

**4.4 Burner dimensions**

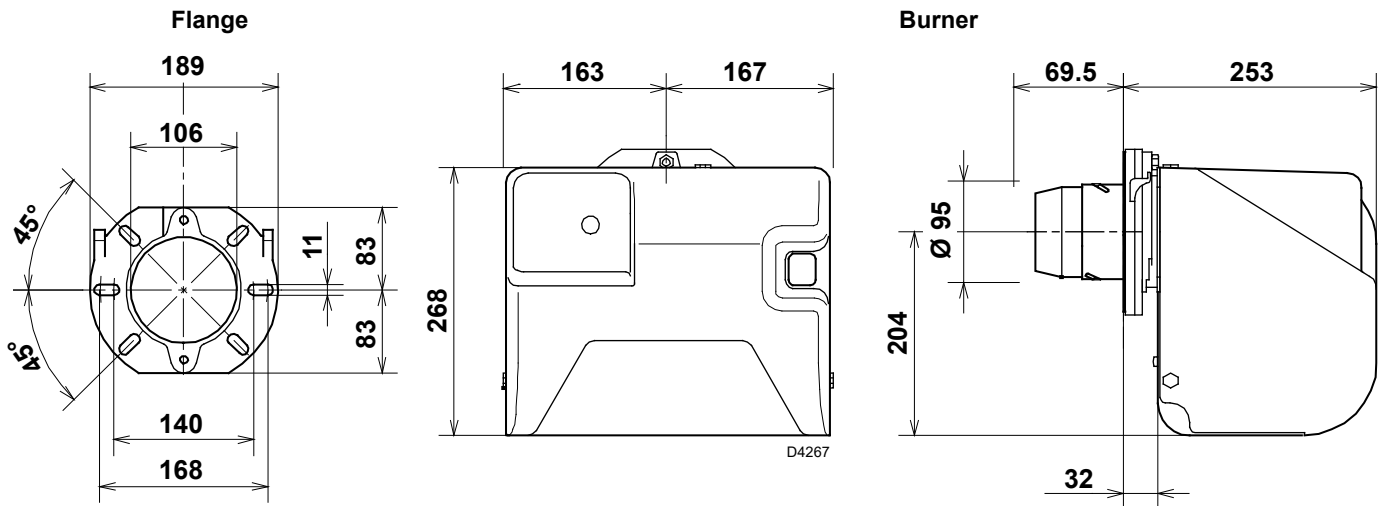

Fig. 2

**4.5 Firing rate**

The **MAXIMUM OUTPUT** is chosen from within the diagram area (Fig. 3).

The **MINIMUM OUTPUT** must not be lower than the minimum limit of the diagram.

The burner delivery must be selected within area of the diagrams (Fig. 3). This area is called firing rates and provides the maximum delivery of the burner in relation to the pressure in the combustion chamber.

The work point may be found by plotting a vertical line from the desired delivery and a horizontal line from the pressure in the combustion chamber. The intersection of these two lines is the work point which must lie within the firing rates.



The firing rate area values have been obtained considering a surrounding temperature of 20 °C, and an atmospheric pressure of 1013 mbar (approx. 0 m above sea level) and with the combustion head adjusted as shown on page 19.

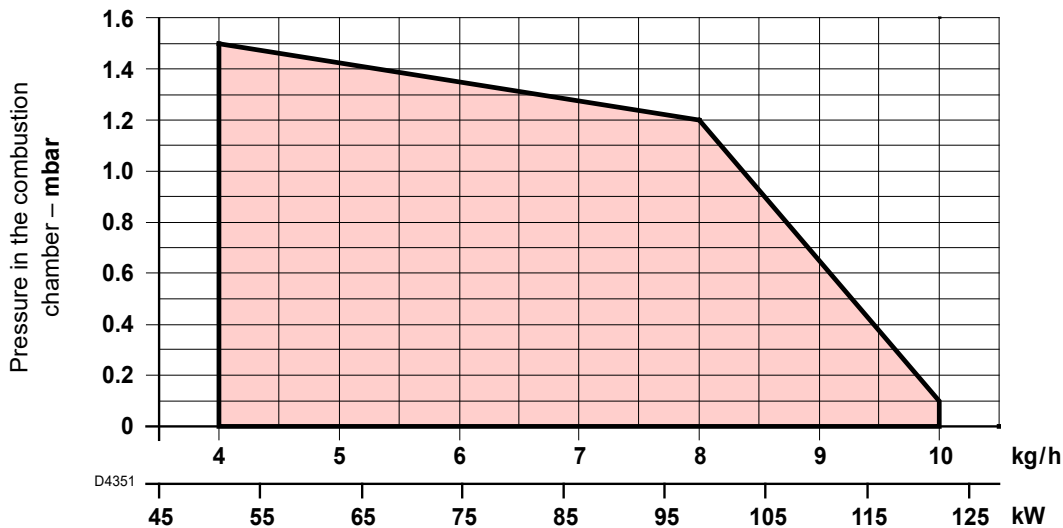

Fig. 3

### 5 Installation

#### 5.1 Notes on safety for the installation

After carefully cleaning all around the area where the burner will be installed, and arranging the correct lighting of the environment, proceed with the installation operations.



All the installation, maintenance and disassembly operations must be carried out with the electricity supply disconnected.



The installation of the burner must be carried out by qualified personnel, as indicated in this manual and in compliance with the standards and regulations of the laws in force.

#### 5.2 Handling

The packaging of the burner includes a carton box, so it is possible to move the burner (still packaged) with a transpallet truck or fork lift truck.



The handling operations for the burner can be highly dangerous if not carried out with the greatest attention: keep any unauthorised people at a distance; check the integrity and suitability of the available means of handling. Check also that the area in which you are working is empty and that there is an adequate escape area (i.e. a free, safe area to which you can quickly move if the burner should fall). When handling, keep the load at not more than 20-25 cm from the ground.



After positioning the burner near the installation point, correctly dispose of all residual packaging, separating the various types of material. Before proceeding with the installation operations, carefully clean all around the area where the burner will be installed.

#### 5.3 Preliminary checks

##### Checking the consignment



After removing all the packaging, check the integrity of the contents. In the event of doubt, do not use the burner; contact the supplier.



The packaging elements (wooden cage or cardboard box, nails, clips, plastic bags, etc.) must not be abandoned as they are potential sources of danger and pollution; they should be collected and disposed of in the appropriate places.

##### Checking the characteristics of the burner

Check the identification label of the burner, showing:

- the model **A**(Fig. 4) and type of burner **B**);
- the year of manufacture, in cryptographic form **C**);
- the serial number **D**);
- the electrical input power **E**);
- the types of fuel used and the relative supply pressures **F**);
- the data of the burner's minimum and maximum output possibilities **G**) (see Firing rate).

R.B.L.	<b>A</b>		<b>B</b>	<b>G</b>
	<b>D</b>	<b>C</b>	D	
	<b>B</b>	<b>E</b>		
	<b>F</b>			CE xxxx

D9370

Fig. 4



The output of the burner must be within the boiler's firing rate.



A burner label that has been tampered with, removed or is missing, along with anything else that prevents the definite identification of the burner makes any installation or maintenance work difficult.

**5.4 Installer/Service notes for the use of Gas oil with Bio blends up to 10%**

- During the burner installation, check that the gas-oil and bio fuel blends are in accordance with Riello specifications (please refer to the chapters "Technical Data" and "Guidance for the use of bio fuel blends up to 10%" within the burner technical manual).
- If a Bio blend is in use the installer must seek information from the end user that their fuel supplier can evidence that the blends of fuel conform to the relevant standards.
- Check that the materials used in the construction of the oil tank and ancillary equipment are suitable for bio fuels, If not these must be upgraded or replaced with Bio compatible parts.
- Particular attention should be given to the oil storage tank and supply to the burner. Riello recommends that existing oil storage tanks are cleaned, inspected and any traces of water are removed BEFORE bio fuel is introduced (Contact the tank manufacturer or oil supplier for further advice). If these recommendations are not respected this will increase the risk of contamination and possible equipment failure.
- In line oil filters should be replaced making sure that they are Bio compatible. Riello recommends a good quality bio compatible oil filter at the tank and a secondary 60 micron filter are used to protect the burner pump and nozzle from contamination.
- The burner hydraulic components and flexible oil lines must be suitable for bio fuel use (check with Riello if in doubt). Riello have carefully chosen the specification of the bio compatible components including the flexible oil lines to protect the pump, safety valve and nozzle. The Riello warranty is dependent upon the use of Riello genuine components including the oil lines, being used. The burner must be commissioned and combustion parameters set to appliance manufacturer's recommendations.
- Regularly check visually for any signs of oil leakage from seals, gaskets and hoses.
- It is strongly recommended that with Bio fuel use, oil filters are inspected and replaced every 4 months. More regularly where contamination is experienced.
- During extended periods of non operation and/or where burners are using oil as a standby fuel, it is strongly recommended that the burner is put into operation for short periods at least every three months.

**5.5 Working position**



**WARNING**

The burner is designed to operate only in the positions **1**, and **3** (Fig. 5). Installation **1** is preferable, as it is the only one that allows performing maintenance operations as described in this manual. Installations **2**, **3** and **4** allow working operations but not maintenance with hooking to the boiler.



**DANGER**

Installation **5** is forbidden for safety reasons.

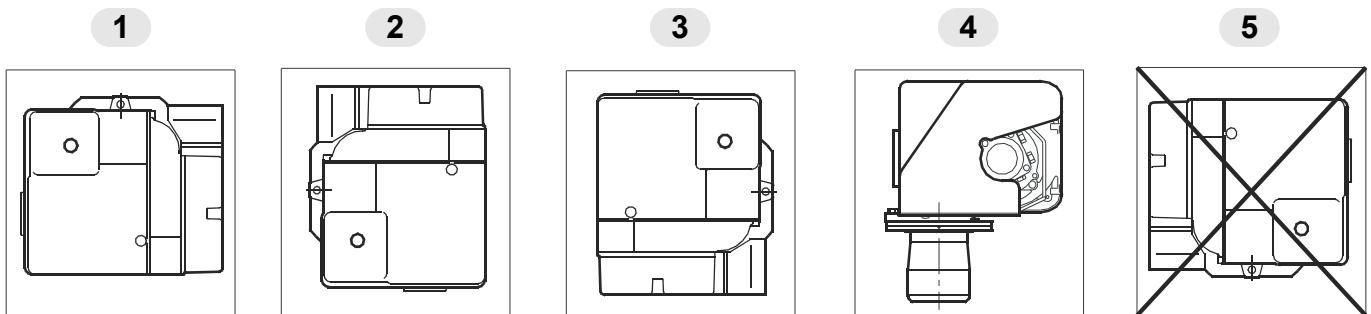

D4618

**Fig. 5**

### 5.6 Boiler fixing

- Fix the bolt 6) and nut 7) onto the flange 1) as in Fig. 6.
- Fix the flange 1) to the appliance 4) using the supplied bolts 2) and nuts 3) with the gasket 5) in-between as in Fig. 7.
- Insert the burner tube through the flange and push to ensure full insertion. With the burner collar fully inserted into the flange the O-ring will form a seal.
- Fix the securing nut 8)(Fig. 6) onto the bolt 6).



**The seal between burner and boiler must be airtight.**

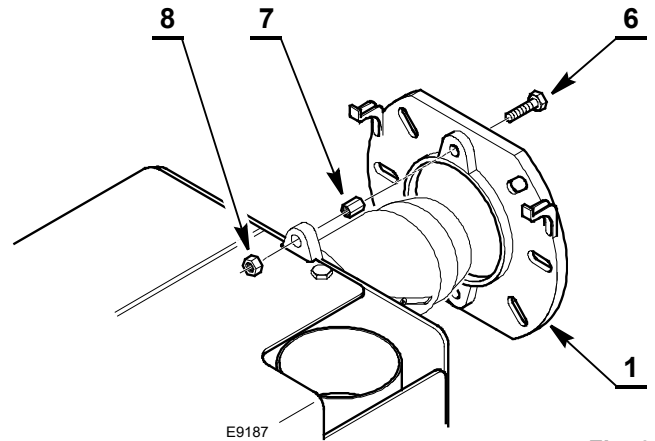

Fig. 6

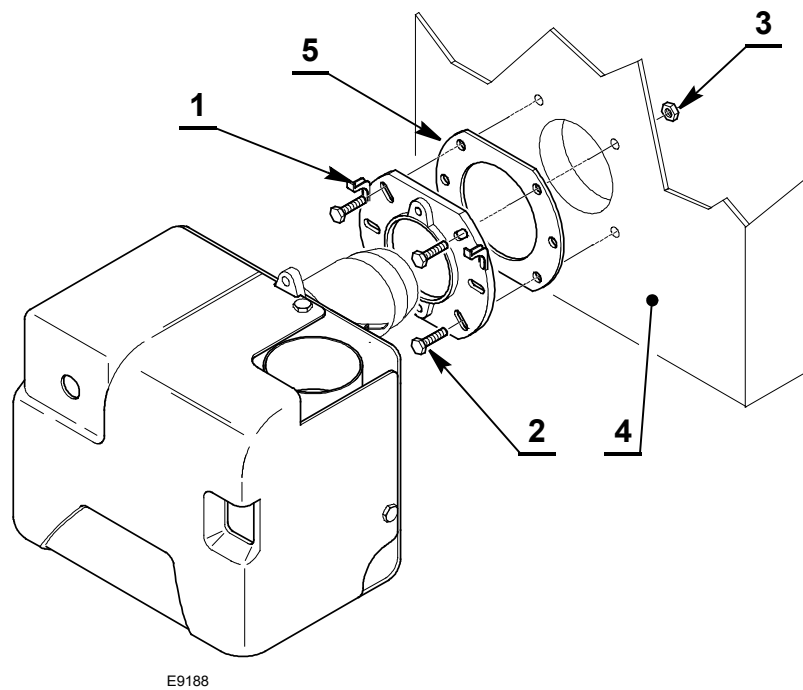

Fig. 7

## 5.7 Mounting the burner

### BF Application



CAUTION

The temperature of the incoming air must not exceed 70 °C.



WARNING

For correct BF application, the burner must be installed on an appropriate BF boiler.

In case of BF applications, the combustion air supply is through a flexible or rigid pipe connected to the air intake A)(Fig. 8).

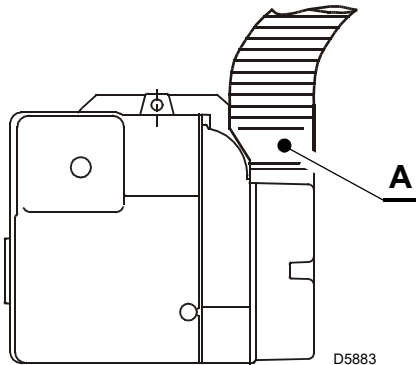

Fig. 8

The combustion air supply is through a flexible or rigid pipe connected to the air intake.

Consequently, you must comply with the following requirements and instructions:

- The combustion air intake tube must be:
  - fastened securely to the burner;
  - made of a suitable material, with temperature characteristics in the range - 30 °C to 80 °C;
  - in compliance with all requirements of applicable regulations in force in the country of destination.
- The intake-tube / burner system must not allow a loss of over 2 m<sup>3</sup>/h at 0.5 mbar:

for instance, the above requirements will be met if you use flues for pressure exhaust of flue gases (the condensation kind).

- Make sure the air intake tube's inlet is positioned so that it is not likely to be obstructed by foreign matter and, where necessary, use suitable screens.
- The inside diameter of the hose must be at least 80 mm.
- The intake tube can be up to 6 metres in length.



WARNING

Length is reduced if there are bends in the intake section.

For instance, using a tube with a smooth inside surface, you must allow for the following losses:

- for each 45° bend, tube length is reduced by 0.5 m;
- for each 90° bend, tube length is reduced by 0.8 m.

### NOTE:

**Burner installation must in any case comply with the flue systems included within the boiler approved configuration.**



WARNING

- Under no circumstances should the air's entry in the hose intake area be obstructed.
- The hose must not be blocked in any way or feature a shutting device (valves, membranes etc.).

**6 Hydraulic systems**

**6.1 Fuel supply**



Explosion danger due to fuel leaks in the presence of a flammable source.

Precautions: avoid knocking, attrition, sparks and heat.

Make sure the fuel interception tap is closed before performing any operation on the burner.



**WARNING**

The fuel supply line must be installed by qualified personnel, in compliance with current standards and laws.

**6.1.1 Pump**

The pump is designed to allow working with one pipe.

In order to obtain two pipes working it is necessary to unscrew the return plug 2)(Fig. 9), screw the by-pass screw 3),supplied as burner equipment and then screw the return hose.

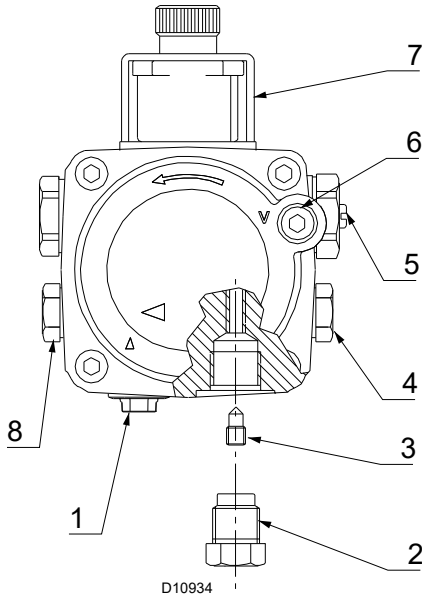

**Fig. 9**

Key (Fig. 9)

- |                    |                                 |
|--------------------|---------------------------------|
| 1 Suction line     | 5 Pressure adjuster             |
| 2 Return line      | 6 Vacuum gauge connection       |
| 3 By-pass screw    | 7 Valve                         |
| 4 Gauge connection | 8 Auxiliary pressure test point |



**WARNING**

Where gas oil containing bio diesel is in use, it is recommended to avoid over oxygenation of the blended fuels.

Where at all possible avoid the use of two pipe systems where the circulated fuel is returned to the tank.

If this cannot be avoided make sure that the return pipe is normally below the surface of the fuel level within the storage tank. See Fig. 12.



**WARNING**

The suction plug 1) is made of plastic. Once removed, it must not be used again.

In single pipe installations, the plug in the return line 2) must be totally in steel.



**WARNING**

In case of use with gas oil containing up to 10% Bio blend, it will be essential to use flexible oil lines suitable for bio fuel use.

Please contact Riello for further information.



**6.2 One pipe system**

Pressurised one pipe systems (Fig. 10) have a positive fuel pressure on intake to the burner.

Usually the tank is higher than the burner, or the fuel pumping systems are on the outside of the boiler.

Vacuum one pipe systems (Fig. 11) have a negative fuel pressure (depression) on intake to the burner.

Usually the tank is lower than the burner.



You are advised to use additional filters on the fuel supply line.

Riello recommends a good quality fuel filter at the tank (Fig. 10 - Fig. 11) and a secondary filter (60 μ for gas oil and 15 μ for kerosene) are used to protect the burner pump and nozzle from contamination.

In case of Biodiesel use, pay attention to install Biocompatible filters.

**6.2.1 Priming pump**

On the system in Fig. 10 it is sufficient to loosen the plug of the vacuum gauge 6)(Fig. 9) and wait until the fuel flows out.

On the system in Fig. 11 start the burner and wait for the priming. Should lock-out occur prior to the arrival of the fuel, await at least 20 seconds before repeating the operation.



The installer must ensure that the supply pressure is not above 0.5 bar.

Above that level, the pump seal is subject to too much stress.

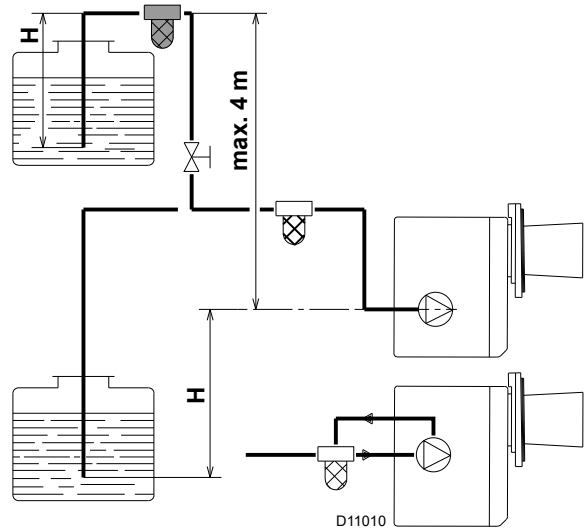

**Fig. 11**

H metres	L metres	
	I.D. (8 mm)	I.D. (10 mm)
0	35	100
0.5	30	100
1	25	100
1.5	20	90
2	15	70
3	8	30
3.5	6	20

**Tab. C**

**H** difference of level  
**L** max. length of the suction line  
**I.D.** internal diameter of the oil pipes

**NOTE:**

The Tab. B and Tab. C show the maximum approximate lengths for the supply line, depending on the difference in level, length, and the diameter of the fuel conduit.

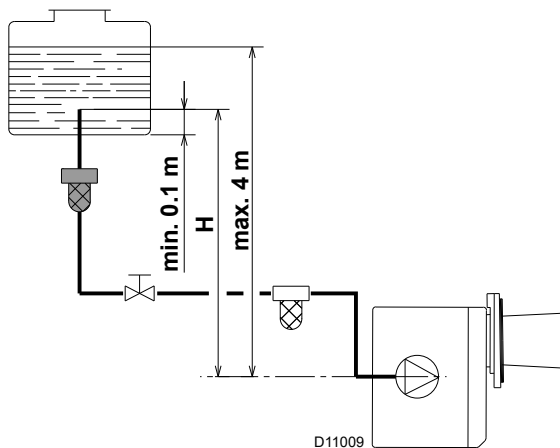

**Fig. 10**

H metres	L metres	
	I.D. (8 mm)	I.D. (10 mm)
0.5	10	20
1	20	40
1.5	40	80
2	60	100

**Tab. B**

**6.3 Two pipe system**

Vacuum two pipe systems (Fig. 12) have a negative fuel pressure (depression) on intake to the burner.

Usually the tank is lower than the burner.

The return line should terminate in the oil tank at the same level as the suction line; in this case a non-return valve is not required.

Should however the return line arrives over the fuel level, the non-return valve is indispensable. This solution however is less safe than previous one, due to the possibility of leakage of the valve.



You are advised to use additional filters on the fuel supply line.

Riello recommends a good quality fuel filter at the tank (Fig. 12) and a secondary filter (60 μ for gas oil and 15 μ for kerosene) are used to protect the burner pump and nozzle from contamination.

In case of Biodiesel use, pay attention to install Biocompatible filters.

**6.3.1 Priming pump**



Before starting the burner make sure that the return pipe-line is not clogged: any obstruction would cause the pump seals to break.

On the system in Fig. 12 start the burner and wait for the priming. Should lock-out occur prior to the arrival of the fuel, await at least 20 seconds before repeating the operation.



The pump vacuum should not exceed a maximum of 0.4 bar (30 cm Hg). Beyond this limit gas is released from the oil.

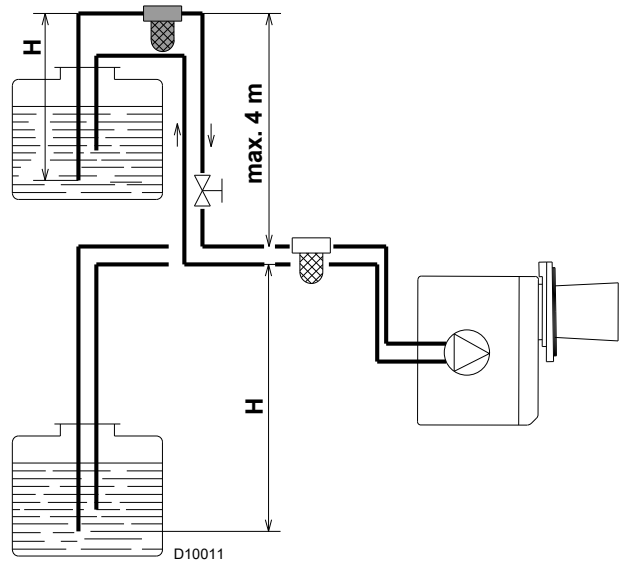

**Fig. 12**

H metres	L metres	
	I.D. (8 mm)	I.D. (10 mm)
0	35	100
0.5	30	100
1	25	100
1.5	20	90
2	15	70
3	8	30
3.5	6	20

**Tab. D**

**H** difference of level  
**L** max. length of the suction line  
**I.D.** internal diameter of the oil pipes

**NOTE:**

The Tab. D shows the maximum approximate lengths for the supply line, depending on the difference in level, length, and the diameter of the fuel conduit.

## 7 Electrical system

### 7.1 Notes on safety for the electrical wiring



**DANGER**

- The electrical wiring must be carried out with the electrical supply disconnected.
- Electrical wiring must be carried out by qualified personnel and in compliance with the regulations currently in force in the country of destination. Refer to the wiring diagrams.
- The manufacturer declines all responsibility for modifications or connections different from those shown in the wiring diagrams.
- Do not invert the neutral with the phase in the electrical supply line. Any inversion would cause a lockout due to firing failure.
- Check that the electrical supply of the burner corresponds to that shown on the identification label and in this manual.
- The burners have been set for intermittent operation. This means they should compulsorily be stopped at least once every 24 hours to enable the control box to perform checks of its own start-up efficiency. Normally the boiler's thermostat/pressure switch ensures the stopping of the burner.  
If this is not the case, it is necessary to apply in series with IN a timer switch that turns off the burner at least once every twenty-four hours. Refer to the wiring diagrams.
- The electrical safety of the device is obtained only when it is correctly connected to an efficient earthing system, made according to current standards. It is necessary to check this fundamental safety requirement. In the event of doubt, have the electrical system checked by qualified personnel.
- The electrical system must be suitable for the maximum input power of the device, as indicated on the label and in the manual, checking in particular that the section of the cables is suitable for the input power of the device.
- For the main power supply of the device from the electricity mains:
  - do not use adapters, multiple sockets or extensions;
  - use an omnipolar switch, as indicated by the current safety standards.
- Do not touch the device with wet or damp body parts and/or in bare feet.
- Do not pull the electric cables.

Before carrying out any maintenance, cleaning or checking operations:



**DANGER**

Disconnect the electrical supply from the burner by means of the main system switch.



**DANGER**

Turn off the fuel interception tap.



**DANGER**

Avoid condensate, ice and water leaks from forming.

If the cover is still present, remove it and proceed with the electrical wiring according to the wiring diagrams.

Use flexible cables in compliance with the EN 60 335-1 standard.



After carrying out maintenance, cleaning or checking operations, reassemble the hood and all the safety and protection devices of the burner.

### 7.2 Electrical wiring

#### 7.2.1 Control box

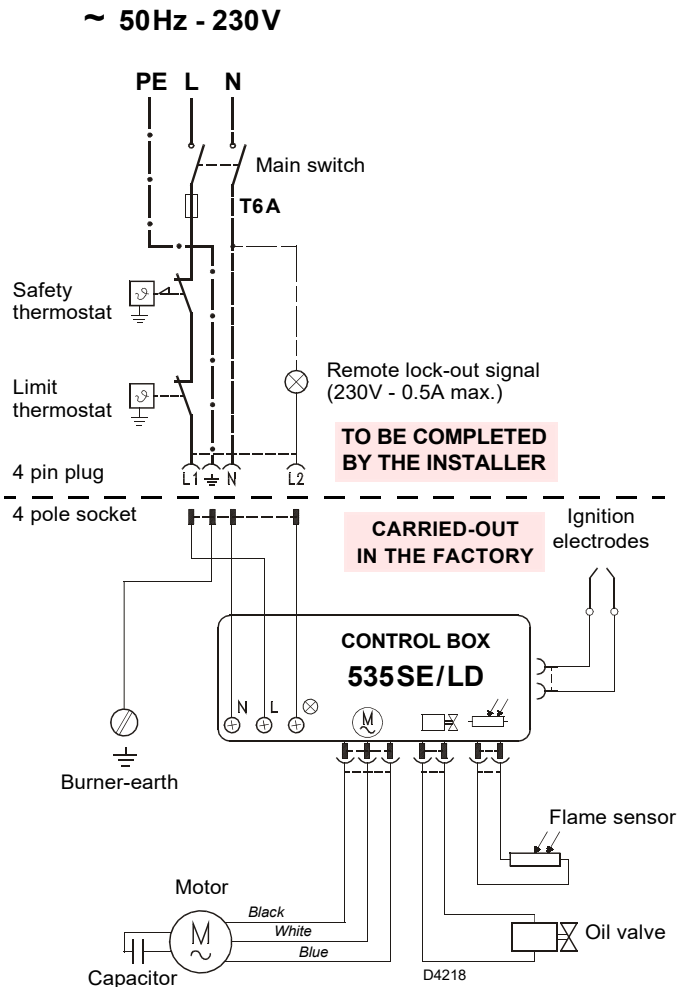

Fig. 13



**WARNING**

- Do not swap neutral and phase over, follow the diagram shown carefully and carry out a good earth connection.
- The electrical wiring carried out by the installer must be in compliance with the rules in force in the country.
- The section of the conductors must be at least  $1\text{mm}^2$ . (Unless requested otherwise by local standards and legislation).

#### TESTING:

Check the shut-down of the burner by opening the thermostats and the lock-out by darkening the flame sensor.



**DANGER**

This operation must be performed with the burner turned off and mains power disconnected.

To remove the control box (Fig. 14) from the burner follow of the instruction:

- loosen the screw 1), open the protection 2) and remove all components.
- Remove the coil 3).
- Loosen the two screws 4).
- Move a little the control box and remove the high voltage leads.

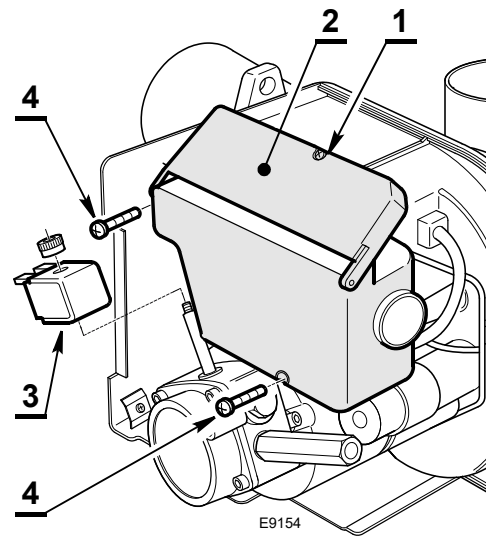

Fig. 14

**8 Start-up, calibration and operation of the burner**

**8.1 Notes on safety for the first start-up**



The first start-up of the burner must be carried out by qualified personnel, as indicated in this manual and in compliance with the standards and regulations of the laws in force.



Check the correct working of the adjustment, command and safety devices.

**8.2 Combustion adjustment**

In conformity with EN 267, the application of the burner on the boiler, adjustment and testing must be carried out observing the instruction manual of the boiler, including verification of the CO and CO<sub>2</sub> concentration in the flue gases, their temperatures and the average temperature of the water in the boiler.



The combustion air is sucked from outside, therefore, there can be sensitive temperature variations that can influence the percentage value of the CO<sub>2</sub>. It is advisable to adjust the CO<sub>2</sub> according to the diagram.

For example: with an combustion air temperature of 20°C, adjust the CO<sub>2</sub> to 12.5% (± 0.2%).

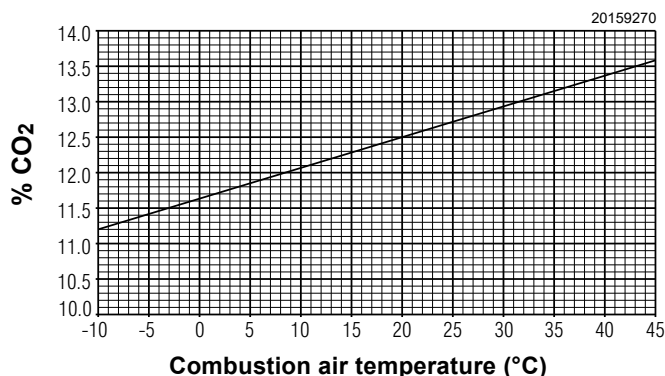

Fig. 15

Fuel	Nozzle		Pump pressure	Burner output	Combustion head adjustment	Air damper adjustment
	GPH	Angle	bar	kg/h ± 4%	Set point	Set point
KEROSENE	1.35	60° W	8	4.04	0	2.2
	1.50	60° W	8	4.49	1	2.8
	1.65	60° W	8	4.93	2	3.1
	1.75	60° W	8	5.23	2	3.5
	2.00	60° W	8	5.98	2	4.3
	2.25	60° W	8	6.73	3	5
	2.50	60° - 45° W	8	7.48	5	6
	2.75	60° - 45° W	8	8.22	5	8
	3.00	60° - 45° W	10	10.03	6	10
GAS OIL	1.00	60° W	12	4.0	0	2.3
	1.10	60° W	12	4.4	1	2.7
	1.25	60° W	12	5.0	2	3.3
	1.35	60° W	12	5.4	2	4
	1.50	60° W	12	6.0	2	4.7
	1.65	60° W	12	6.6	3	5
	1.75	60° W	12	7.0	4	6
	2.00	60° - 45° W	12	8.0	5	7
	2.25	60° - 45° W	12	9.0	6	8.4
2.50	60° - 45° W	12	10.0	6	10	

Tab. E

### 8.3 Nozzles installation

The burner complies with the emission requirements of the EN 267 standard. In order to guarantee that emissions do not vary, recommended and/or alternative nozzles specified by the manufacturer in the Instruction and warning booklet should be used.



It is advisable to replace nozzles every year during regular maintenance operations.



The use of nozzles other than those specified by the manufacturer and inadequate regular maintenance may result into emission limits non-conforming to the values set forth by the regulations in force, and in extremely serious cases, into potential hazards to people and objects. The manufacturing company shall not be liable for any such damage arising from nonobservance of the requirements contained in this manual.

#### 8.3.1 Nozzles recommended

- Hago type ES - B;
- Steinen type S;
- Danfoss type S;
- Delavan type W - B (not for 45° gas oil).  
Use Delavan type W CSA.

### 8.4 Pump pressure

The pump leaves the factory set for kerosene working.

**10 bar:** maximum pressure for kerosene.

#### FOR GAS OIL INCREASE PRESSURE

**12 bar:** pressure suitable for light oil in most cases.

**14 bar:** improves flame retention; it is therefore suitable for ignitions at low temperatures.

### 8.5 Air damper adjustment

The settings indicated in the Tab. E refer to the combustion-chamber with "zero" depression.

These regulations are purely indicative.

Each installation however, has its own unpredictable working conditions: actual nozzle output; positive or negative pressure in the combustion-chamber, the need of excess air, etc.

All these conditions may require a different air-damper setting.

### 8.6 Combustion head adjustment

To adjust the combustion head, proceed as follows:

- loosen the two screws 1)(Fig. 16) in the ring slots 2);
- turn the blast tube 3) to regulate it, until the end of the slotted ring centres up with the notch shown in the Tab. E.

#### Turn in a clockwise direction:

in order to increase the volume of air entering the combustion chamber and thus diminishing its pressure. There is a reduction of CO<sub>2</sub> and the adhesion of the flame to the air diffuser disc improves. (Setting advisable for ignitions at low temperatures).

#### Turn in an anticlockwise direction:

in order to reduce the volume of air entering the combustion chamber and thus increasing its pressure. The CO<sub>2</sub> improves and the adhesion of the flame to the diffuser tends to reduce. (This setting is not advisable for ignitions at low temperatures).

- Tighten the two screws 1).

In the Fig. 16, the combustion head is adjusted at set-point 3.5. Combustion head settings indicated in Tab. E are valid for most cases.

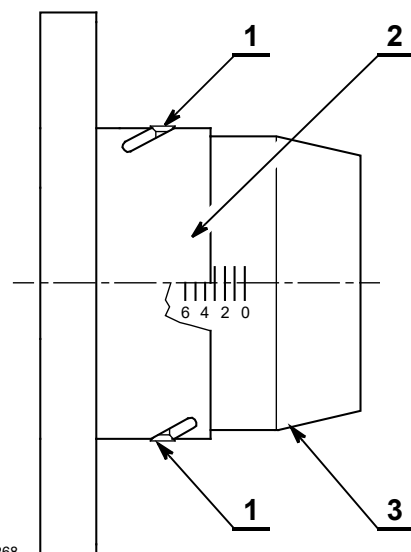

D4268

Fig. 16

**8.7 Diffuser disc unit and electrodes setting**

To adjust the diffuser disc unit, proceed as follows:

- Loosen the screw 1)(Fig. 17) and move the diffuser disc unit up to level **A**.
- Tighten the screw 1).

To adjust the electrodes unit, proceed as follows:

- Loosen the screw 2)(Fig. 17) and move the electrodes unit up to level **B**.
- Tighten the screw 2).

<b>A</b>	$7.5 \begin{matrix} +0.7 \\ -0.5 \end{matrix}$
<b>B</b>	$4 \pm 0.5$
<b>C</b>	$3 \begin{matrix} +0.5 \\ 0 \end{matrix}$
<b>D</b>	$5.75 \begin{matrix} 0 \\ -0.2 \end{matrix}$

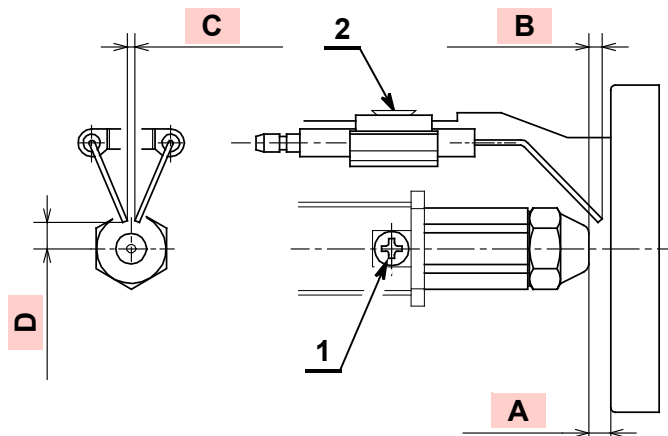
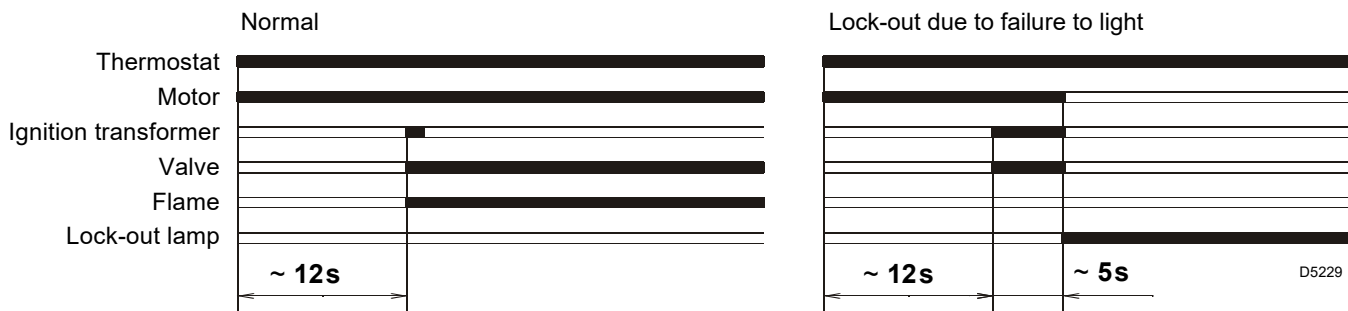

Fig. 17

**8.8 Burner start-up cycle**



D5229

Fig. 18

Lock out is indicated by a lamp on the control box 1)(Fig. 1 to page 8).

**9 Maintenance**

**9.1 Notes on safety for the maintenance**

The periodic maintenance is essential for the good operation, safety, yield and duration of the burner.

It allows you to reduce consumption and polluting emissions and to keep the product in a reliable state over time.



The maintenance interventions and the calibration of the burner must only be carried out by qualified, authorised personnel, in accordance with the contents of this manual and in compliance with the standards and regulations of current laws.

Before carrying out any maintenance, cleaning or checking operations:



Disconnect the electrical supply from the burner by means of the main system switch.



Turn off the fuel interception tap.



Wait for the components in contact with heat sources to cool down completely.

**9.2 Maintenance programme**

**9.2.1 Maintenance frequency**



The gas combustion system should be checked at least once a year by a representative of the manufacturer or another specialised technician.

**9.2.2 Checking and cleaning**



The operator must use the required equipment during maintenance.

**Combustion head**

Open the burner and make sure that all components of the combustion head are in good condition, not deformed by the high temperatures, free of impurities from the surroundings and correctly positioned.

Clean the combustion head in the fuel exit area, on the diffuser disc.

**Burner**

Check for excess wear or loose screws and clean the outside of the burner.

**Fan**

Check to make sure that no dust has accumulated inside the fan or on its blades, as this condition will cause a reduction in the air flow rate and provoke polluting combustion.

**Flame sensor**

Clean the flame sensor.

**Electrodes**

Check the correct position of electrodes

**Nozzles**

It is advisable to replace nozzles every year during regular maintenance operations.

Do not clean the nozzle openings; do not even open them.

**Filters**

Check the filtering baskets on line and at nozzle present in the system. Clean or replace if necessary.

If rust or other impurities are observed inside the pump, use a separate pump to lift any water and other impurities that may have deposited on the bottom of the tank.

**Pump**

Delivery pressure must correspond with the table on Tab. E to page 19. Please check that the supply line and filters are clear. The use of a pump vacuum gauge will assist in this. This measure permits the cause of the anomaly to be traced to either the suction line or the pump.

If the problem lies in the suction line, check to make sure that the filter is clean and that air is not entering the piping.

**Hoses**

- Check periodically the flexible pipes conditions. They have to be replaced at least **every 2 years**.
- In case of use of gas oil and bio fuel blends, it is strongly recommended to inspect **even more frequently** the hoses and replace them where contamination has occurred.
- Check to make sure that the hoses are still in good condition.



The hoses supplied with this burner set for Kerosene use are not suitable for use with Gas oil containing a Bio blend.



Any contact with elements such solvents, thinners or cleaning fluids that have a polar base, along with any aggressive elements present within the fuel will void any warranty of the flexible hose.

**Fuel tank**

If water or contamination is present within the fuel tank, it is essential that this is removed before the equipment is to be used. This is extremely important when gas oil containing Bio diesel is in use. If in doubt about how to achieve this then please contact the fuel or oil tank supplier.



**Boiler**

Clean the boiler as indicated in the appliance accompanying instructions in order to maintain all the original combustion characteristics intact, especially the flue gas temperature and combustion chamber pressure.

**Combustion**

In case the combustion values found at the beginning of the intervention do not respect the standards in force or, in any case, do not correspond to a proper combustion, contact the Technical Assistant and have him carry out the necessary adjustments.

Allow the burner to work for 10 min. and then check the combustion readings with the parameters indicated within the appliance instruction manual. **Then carry out a combustion check verifying:**

- Smoke temperature at the chimney;
- Content of CO<sub>2</sub> (%);
- Content of CO (ppm);
- Smoke value according to opacity smokes index according to Bacharach scale.

**9.2.3 Safety components**

The safety components must be replaced at the end of their life cycle indicated in Tab. F. The specified life cycles do not refer to the warranty terms indicated in the delivery or payment conditions.

Safety component	Life cycle
Flame control	10 years or 250.000 operation cycles
Flame sensor	10 years or 250.000 operation cycles
Gas valves (solenoid)	10 years or 250.000 operation cycles
Pressure switches	10 years or 250.000 operation cycles
Pressure adjuster	15 years
Servomotor (electronic cam) (if present)	10 years or 250.000 operation cycles
Oil valve (solenoid) (if present)	10 years or 250.000 operation cycles
Oil regulator (if present)	10 years or 250.000 operation cycles
Oil pipes/ couplings (metallic) (if present)	10 years
Fan impeller	10 years or 500.000 start-ups

Tab. F

**9.3 Maintenance position**



Disconnect the electrical supply from the burner by means of the main system switch.



Turn off the fuel interception tap.



Wait for the components in contact with heat sources to cool down completely.

To access to the combustion head, the diffuser disc-holder assembly, electrodes and nozzle

- Loosing the fixing nut to the flange and remove the burner out of the boiler.
- Hook the burner to the flange 1)(Fig. 19), by removing the blast tube 2) after loosening the fixing screws 3).
- Remove the small cables 4) from the electrodes 5) and the diffuser disc-holder assembly from the nozzle-holder 6) after loosening its fixing screw 7).
- Once replacement of the nozzle has been made, screw it and tighten it as shown in the Fig. 19.

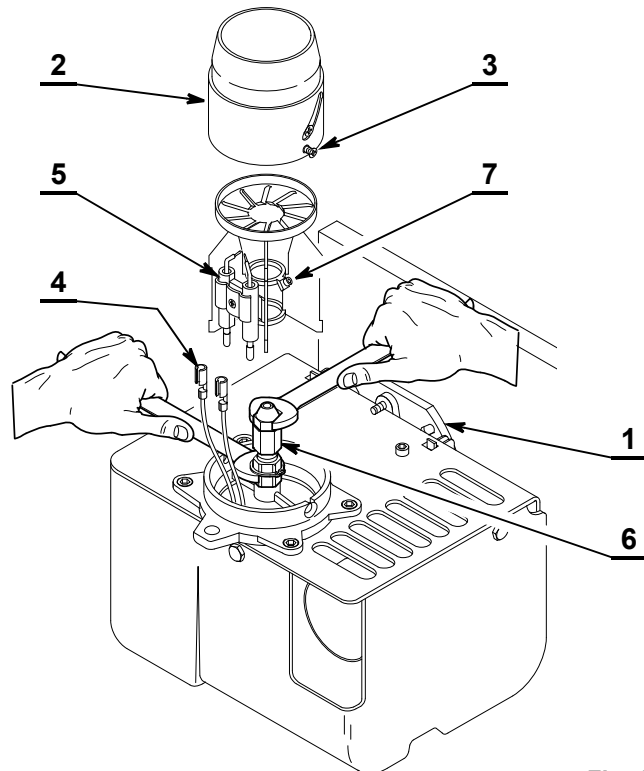

Fig. 19



After carrying out maintenance, cleaning or checking operations, reassemble the hood and all the safety and protection devices of the burner.

**10** **Faults - Probable causes - Solutions**

Here below you can find some causes and the possible solutions for some problems that could cause a failure to start or incorrect operation of the burner.

A fault usually makes the lock-out lamp light which is situated inside the reset button of the control box 1)(Fig. 1 to page 8).

When lock out lamp lights the burner will attempt to light only after pushing the reset button. After this if the burner functions correctly, the lock-out can be attributed to a temporary fault.

If however the lock out continues the cause must be determined and the solution found.

<b>Faults</b>	<b>Possible causes</b>	<b>Solutions</b>
The burner will not start when the limit thermostat closes.	Lack of electrical supply.	Check presence of voltage in the L - N clamps of the control box. Check the conditions of the fuses. Check that safety thermostat limit is not lock out.
	The flame sensor sees false light.	Eliminate the light.
	The connections in the control box are wrongly inserted.	Check and connect completely all the plugs.
Burner runs normally in the prepurge and ignition cycle and locks out after 5 seconds ca.	The flame sensor is dirty.	Clean it.
	The flame sensor is defective.	Change it.
	Flame moves away or fails.	Check pressure and output of the fuel. Check air output. Change nozzle. Check the coil of solenoid valve.
Burner starts with an ignition delay.	The ignition electrodes are wrongly positioned.	Adjust them according to the instructions of this manual.
	Air output is too high.	Set the air output.
	Nozzle dirty or worn.	Replace it.

**Tab. G**



**WARNING**

The manufacturer cannot accept responsibility for any damage to persons, animals or property due to error in installation or in the burner adjustment, or due to improper or unreasonable use or non observance of the technical instruction enclosed with the burner, or due to the intervention of un-qualified personnel.



---

**RIELLO**

RIELLO S.p.A.  
I-37045 Legnago (VR)  
Tel.: +39.0442.630111  
[http:// www.riello.it](http://www.riello.it)  
[http:// www.riello.com](http://www.riello.com)