

## **Bruciatori di nafta** **Heavy oil burners** **Brûleurs fioul lourd** **Schwerölbrenner** **Quemadores de nafta**

Funzionamento bistadio  
Two-stage operation  
Fonctionnement à deux allures  
Zweistufiger Betrieb  
Funcionamiento de dos llama

COD.	MOD.	TYP.
<b>3435023</b>	<b>PRESS 60 N/ECO</b>	<b>628 T</b>
<b>3435024</b>	<b>PRESS 60 N/ECO</b>	<b>628 T</b>
<b>3436023</b>	<b>PRESS 100 N/ECO</b>	<b>629 T</b>
<b>3436024</b>	<b>PRESS 100 N/ECO</b>	<b>629 T</b>

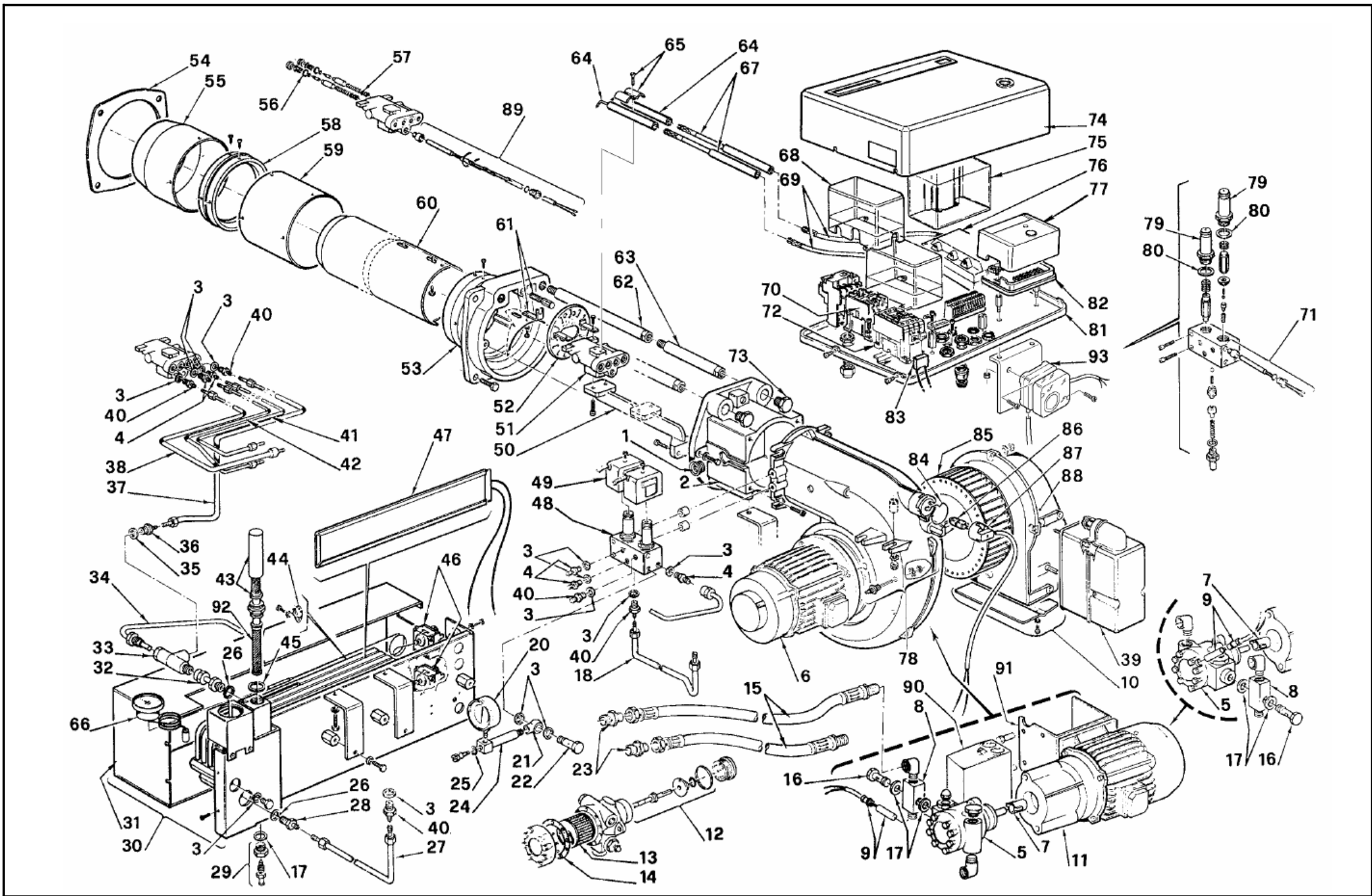

N.	COD.	628 T		629 T		DESCRIZIONE	DESCRIPTION	DESCRIPTION	BESCHREIBUNG	DENOMINACION	MATRICOLA BRUCIATORE BURNER SERIAL NUMBER MATICULE BRULEUR BRENNER KENN-NUMMER MATRICULA QUEMADORES	RICAMBI CONSIGLIATI ADVISED PARTS RECHANGE CONSEIL EMPFOHLENE ERSATZTEILE RECAMBIOS ACONSEJADOS
		3435023	3435024 *	3436023	3436024 *							
1	3003464	●	●	●	●	TAPPO	PLUG	BOUCHON A VIS	SCHRAUBSTÖPSEL	TAPON		
2	3003482	●	●	●	●	MANICOTTO	MANIFOLD	MANCHON	GASANSCHLUSS	MANGUITO		
2	3003486	●	●	●	●	MANICOTTO	MANIFOLD	MANCHON	GASANSCHLUSS	MANGUITO		
3	3007079	●	●	●	●	GUARNIZIONE	SEAL	JOINT COUVERCLE POMPE	PUMPENDICHTUNG	JUNTA		B
4	3003005	●	●	●	●	RACCORDO	CONNECTOR	MAMELON	NIPPEL	RACORD		C
5	3003027	●	●	●	●	POMPA	PUMP	POMPE	PUMPEL	BOMBA		B
5	3006156	●	●	●	●	POMPA	PUMP	POMPE	PUMPEL	BOMBA		B
6	3006618	●	●	●	●	MOTORE	MOTOR	MOTEUR	MOTOR	MOTOR		C
6	3003427	●	●	●	●	MOTORE	MOTOR	MOTEUR	MOTOR	MOTOR		C
7	3003557	●	●	●	●	GIUNTO	JOINT	ACCOUPLLEMENT	KUPPLUNG	CONJUNTO		A
8	3003055	●	●	●	●	RACCORDO	CONNECTOR	MAMELON	NIPPEL	RACORD		C
9	3003570	●	●	●	●	RESISTENZA	RESISTANCE	RESISTANCE	WIDERSTAND	RESISTENCIA		B
10	3003317	●	●	●	●	GRUPPO SERRANDA	AIR DAMPER ASSEMBLY	GROUPE VOLET AIR	LUFTKLAPPE	REGISTRO AIRE		
10	3003318	●	●	●	●	GRUPPO SERRANDA	AIR DAMPER ASSEMBLY	GROUPE VOLET AIR	LUFTKLAPPE	REGISTRO AIRE		
11	3003568	●	●	●	●	MOTORE	MOTOR	MOTEUR	MOTOR	MOTOR		C
12	3000766	●	●	●	●	ORGANO DI TENUTA	PUMP SEAL	ORGANE D'ETANCHEITE	WELLENDICHTUNG	CONJUNTO ESTANQUIDAD		
13	3006308	●	●	●	●	FILTRO	FILTER	FILTRE	FILTER	FILTRO		A
14	3006292	●	●	●	●	GUARNIZIONE	SEAL	RONDELLE	METALLDICHTUNG	JUNTA		A
15	3012714	●	●	●	●	TUBO FLESSIBILE	FLEXIBLE OIL LINE	FLEXIBLE	SCHLAUCH	TUBO FLEXIBILE		A
16	3006184	●	●	●	●	PERNO	BAR	GLISSIERE	BOLZEN	JUNTA		C
17	3007164	●	●	●	●	GUARNIZIONE	SEAL	RONDELLE	METALLDICHTUNG	JUNTA		B
18	3003571	●	●	●	●	TUBO	TUBE	TUYAUTERIE	DRUCKROHR	TUBO		
18	3003572	●	●	●	●	TUBO	TUBE	TUYAUTERIE	DRUCKROHR	TUBO		
20	3006140	●	●	●	●	MANOMETRO	PRESSURE GAUGE	MANOMETRE	MANOMETER	MANÓMETRO		A
21	3006429	●	●	●	●	RACCORDO	CONNECTOR	MAMELON	NIPPEL	RACORD		C
22	3003006	●	●	●	●	RACCORDO	CONNECTOR	MAMELON	NIPPEL	RACORD		C
23	3006181	●	●	●	●	RACCORDO	CONNECTOR	MAMELON	NIPPEL	RACORD		C
24	3006540	●	●	●	●	VALVOLA	NEEDLE VALVE	ROBINET POINTEAU	NADELVENTIL	VÁLVULA		C
25	3007169	●	●	●	●	ANELLO OR	O RING	JOINT TORIQUE	O - RING	JUNTA TORICA		B
26	3007082	●	●	●	●	GUARNIZIONE	SEAL	RONDELLE	METALLDICHTUNG	JUNTA		B
27	3003573	●	●	●	●	TUBO	TUBE	TUYAUTERIE	DRUCKROHR	TUBO		
27	3003574	●	●	●	●	TUBO	TUBE	TUYAUTERIE	DRUCKROHR	TUBO		
28	3009084	●	●	●	●	RACCORDO	CONNECTOR	MAMELON	NIPPEL	RACORD		C
29	3006423	●	●	●	●	VALVOLA DI SCARICO	EXHAUST VALVE	BOUCHON DE PURGE	ENTLEERUNGSVENTIL	VÁLVULA DE ESCAPE		C
30	3003575	●	●	●	●	SERBATOIO	PRE - HEART	RESERVOIR	ÖLVORWÄRMER	JUNTA PRECALENTA DOR		A
30	3003576	●	●	●	●	SERBATOIO	PRE - HEART	RESERVOIR	ÖLVORWÄRMER	JUNTA PRECALENTA DOR		A
31	3003487	●	●	●	●	COPERCHIO	COVER	COUVERCLE	DECKEL	TAPA		
31	3003488	●	●	●	●	COPERCHIO	COVER	COUVERCLE	DECKEL	TAPA		
32	3003472	●	●	●	●	RACCORDO	CONNECTOR	MAMELON	NIPPEL	RACORD		C
33	3006870	●	●	●	●	VALVOLA ANTIGAS	BACK - PRESSURE VALVE	VANNE ANTIGAZ	GEGENGASBILDUNGSVENTIL	VÁLVULA CONTRA-GAS		C
34	3003473	●	●	●	●	TUBO	TUBE	TUYAUTERIE	DRUCKROHR	TUBO		
34	3003489	●	●	●	●	TUBO	TUBE	TUYAUTERIE	DRUCKROHR	TUBO		
35	3007077	●	●	●	●	GUARNIZIONE	SEAL	RONDELLE	METALLDICHTUNG	JUNTA		B
36	3006720	●	●	●	●	RACCORDO	CONNECTOR	MAMELON	NIPPEL	RACORD		C

N.	COD.	628 T		629 T		DESCRIZIONE	DESCRIPTION	DESCRIPTION	BESCHREIBUNG	DENOMINACION	MATRICOLA BRUCIATORE BURNER SERIAL NUMBER MATRICULE BRULEUR BRENNER KENN-NUMMER MATRICULA QUEMADORES	RICAMBI CONSIGLIATI ADVISED PARTS RECHANGE CONSEIL EMPFOHLENE ERSATZTEILE RECAMBIOS ACONSEJADOS
		3435023	3435024 *	3436023	3436024 *							
36	3003469			•	•	RACCORDO	CONNECTOR	MAMELON	NIPPEL	RACORD		C
37	3003490	•				TUBO	TUBE	TUYAUTERIE	DRUCKROHR	TUBO		
37	3003477		•			TUBO	TUBE	TUYAUTERIE	DRUCKROHR	TUBO		
37	3003491			•		TUBO	TUBE	TUYAUTERIE	DRUCKROHR	TUBO		
37	3003492				•	TUBO	TUBE	TUYAUTERIE	DRUCKROHR	TUBO		
38	3003042	•				TUBO	TUBE	TUYAUTERIE	DRUCKROHR	TUBO		
38	3003024		•			TUBO	TUBE	TUYAUTERIE	DRUCKROHR	TUBO		
38	3003043			•		TUBO	TUBE	TUYAUTERIE	DRUCKROHR	TUBO		
38	3003045				•	TUBO	TUBE	TUYAUTERIE	DRUCKROHR	TUBO		
39	3006311	•	•	•	•	SERVOMOTORE	SERVOMOTOR	SERVOMOTEUR	STELLMOTOR	SERVOMOTOR		B
40	3006723	•	•			RACCORDO	CONNECTOR	MAMELON	NIPPEL	RACORD		C
40	3009081			•	•	RACCORDO	CONNECTOR	MAMELON	NIPPEL	RACORD		C
41	3003046	•				TUBO	TUBE	TUYAUTERIE	DRUCKROHR	TUBO		
41	3003016		•			TUBO	TUBE	TUYAUTERIE	DRUCKROHR	TUBO		
41	3003047			•		TUBO	TUBE	TUYAUTERIE	DRUCKROHR	TUBO		
41	3003049				•	TUBO	TUBE	TUYAUTERIE	DRUCKROHR	TUBO		
42	3003030	•				TUBO	TUBE	TUYAUTERIE	DRUCKROHR	TUBO		
42	3003020		•			TUBO	TUBE	TUYAUTERIE	DRUCKROHR	TUBO		
42	3003031			•		TUBO	TUBE	TUYAUTERIE	DRUCKROHR	TUBO		
42	3003033				•	TUBO	TUBE	TUYAUTERIE	DRUCKROHR	TUBO		
43	3003528	•	•	•	•	FILTRO DOPPIO	DOUBLE FILTER	DOUBLE FILTRE	DOPPEL FILTER	FILTRO DOBLE		B
44	3012421	•	•	•	•	TERMOSTATO DI MINIMA	LOW POINT THERMOSTAT	THERMOSTAT MINIMAL	THERMOSTAT MIN.	TERMÓSTATO DEL MINIM		A
45	3007090	•	•	•	•	GUARNIZIONE	SEAL	RONDELLE	METALLDICHTUNG	JUNTA		B
46	3006444	•	•	•	•	TERMOSTATO	THERMOSTAT	THERMOSTAT	THERMOSTAT	TERMÓSTATO		B
47	3006067	•	•	•	•	RESISTENZA	RESISTANCE	RESISTANCE	WIDERSTAND	RESISTENCIA		B
48	3003503	•	•	•	•	GRUPPO VALVOLE	VALVA ASSEMBLY	GROUPE ELECTROVANNE	MAGNETVENTILBLOCK	CONJUNTO VÁLVULA		B
49	3003001	•	•	•	•	BOBINA	COIL	BOBINE E.V.	MV - SPULE	BOBINA		B
50	3006454	•				STAFFA CORTA	SHORT BRACKET	SUPPORT COURT	KURZER HALTERUNG	SOPORTE CORTO		
50	3006453		•			STAFFA LUNGA	LONG BRACKET	SUPPORT LONG	LANGE HALTERUNG	SOPORTE LARGO		
50	3006457			•		STAFFA CORTA	SHORT BRACKET	SUPPORT COURT	KURZER HALTERUNG	SOPORTE CORTO		
50	3006458				•	STAFFA LUNGA	LONG BRACKET	SUPPORT LONG	LANGE HALTERUNG	SOPORTE LARGO		
51	3006420	•	•	•	•	POLVERIZZATORE	NOZZLE HOLDER	PULVERISATEUR	DÜSENSTOCK	PORTABOQUILLA		B
52	3005926	•	•			ELICA	DIFFUSER DISC	ACCROCHE FLAMME	STAUSCHEIBE	DISCO ESTABILIZADOR		A
52	3005516			•	•	ELICA	DIFFUSER DISC	ACCROCHE FLAMME	STAUSCHEIBE	DISCO ESTABILIZADOR		A
53	3006455	•	•			BOCCAGLIO	BLAST TUBE	GUEULARD	BRENNERFLANSCH	TUBO LLAMA		
53	3006456			•	•	BOCCAGLIO	BLAST TUBE	GUEULARD	BRENNERFLANSCH	TUBO LLAMA		
54	3005741	•	•			SCHERMO	FLANGE GASKET	ECRAN THERMIQUE	FLANSCHDICHTUNG	JUNTA AISLANTE		A
54	3005742			•	•	SCHERMO	FLANGE GASKET	ECRAN THERMIQUE	FLANSCHDICHTUNG	JUNTA AISLANTE		A
55	3006483	•	•			IMBUTO FIAMMA	END CONE	EMBOUT GUEULARD	FLAMMENROHR	TUBO EXTREMO		B
55	3006484			•	•	IMBUTO FIAMMA	END CONE	EMBOUT GUEULARD	FLAMMENROHR	TUBO EXTREMO		B
56	3007025	•	•	•	•	ANELLO OR	O RING	JOINT TORIQUE	O - RING	JUNTA TORICA		B
57	3005372	•	•	•	•	GUARNIZIONE	SEAL	RONDELLE	METALLDICHTUNG	JUNTA		B
58	3006493		•			DENTE	CONNECTION SLEEVE	JONCTION	STAURING	ANILLO LLAMA		
58	3006495			•		DENTE	CONNECTION SLEEVE	JONCTION	STAURING	ANILLO LLAMA		

N.	COD.	628 T		629 T		DESCRIZIONE	DESCRIPTION	DESCRIPTION	BESCHREIBUNG	DENOMINACION	MÁTRICOLA BR UCIA TORE BURNER SERIAL NUMBER MATRICULE BRULEUR BRENNER KENN-NUMMER MATRICULA QUEMADORES	RICAMBI CONSIGLIATI ADVISED PARTS RECHANGE CONSEIL EMPFOHLENE ERSATZTEILE RECAMBIOS A CONSEJADOS
		3435023	3435024 *	3436023	3436024 *							
59	3006492	•				CILINDRO	SLEEVE	CYLINDRE	ZYLINDER	CILINDRO		C
59	3006494		•			CILINDRO	SLEEVE	CYLINDRE	ZYLINDER	CILINDRO		C
60	3006487	•				CILINDRO CORTO	SHORT SLEEVE	CYLINDRE COURT	KURZER ZYLINDER	CILINDRO CORTO		C
60	3006488		•			CILINDRO LUNGO	LONG SLEEVE	CYLINDRE LONG	LANGER ZYLINDER	CILINDRO LARGO		C
60	3006489			•		CILINDRO CORTO	SHORT SLEEVE	CYLINDRE COURT	KURZER ZYLINDER	CILINDRO CORTO		C
60	3006490				•	CILINDRO LUNGO	LONG SLEEVE	CYLINDRE LONG	LANGER ZYLINDER	CILINDRO LARGO		C
61	3003493	•	•			GRUPPO AVANZAMENTO	ADJUSTMENT ASSEMBLY	GROUPE ENTRAINEMENT	VORSCHUB HEBELSYSTEMG	RUPO DE AJUSTE		
61	3003478			•	•	GRUPPO AVANZAMENTO	ADJUSTMENT ASSEMBLY	GROUPE ENTRAINEMENT	VORSCHUB HEBELSYSTEM	GRUPO DE AJUSTE		
62	3003479	•	•			PERNO	BAR	GLISSIERE	BOLZEN	GUÍA		
62	3003494			•	•	PERNO	BAR	GLISSIERE	BOLZEN	GUÍA		
63	3006496		•			PROLUNGA PERNO	BAR EXTENSION	RALLONGE DE GLISSIERE	VERLÄNGERUNG	PROLUNGACIÓN GUÍA		
63	3006497				•	PROLUNGA PERNO	BAR EXTENSION	RALLONGE DE GLISSIERE	VERLÄNGERUNG	PROLUNGACIÓN GUÍA		
64	3004842	•	•	•	•	ELETTRODO	ELECTRODE	ELECTRODE PORCELAINE	ELEKTRODE	ELECTRODO		A
65	3003495	•	•	•	•	CAVALLOTTO	U BOLT	CAVALIER	BÜGELBOLZEN	FIJACION ELECTRODO		
66	3006927	•	•	•	•	TERMOMETRO	THERMOMETER	THERMOMETRE	THERMOMETER	TERMÓMETRO		C
67	3000478		•		•	PROLUNGA ELETTRODO	ELECTRODE EXTENSION	RALLONGE ELECTRODE	ELEKTRODE VERLÄNGERUNG	PROLUNGACIÓN ELECTRODO		A
68	3003072	•	•	•	•	COPERCHIO	COVER	COUVERCLE	DECKEL	TAPA		
69	3003973	•	•	•	•	COLLEGAMENTO	H.T. LEAD	CABLE H.T.	ZÜNDKABEL	CABLE ALTA TENSIÓN		A
70	3003566	•	•			AVVIATORE	STARTER	DEMARREUR	ANLASSER	ARRANCADOR		C
70	3003567			•	•	AVVIATORE	STARTER	DEMARREUR	ANLASSER	ARRANCADOR		C
71	3003618	•	•	•	•	GRUPPO RESISTENZA	HEATER GROUP	GROUPE RESISTANCE	HEIZWIDERSTAND	GRUPO RESISTENCIA		B
72	3003624	•	•	•	•	CONTATTORE	CONTACTOR	CONTACTEUR	SCHÜTZ	CONTACTOR		C
73	3003481	•	•			VITE	SCREW	VIS	SCHRAUBE	TORNILLO		
73	3003496			•	•	VITE	SCREW	VIS	SCHRAUBE	TORNILLO		
74	3003483	•	•	•	•	COPERCHIO	COVER	COUVERCLE	DECKEL	ENVOLVENTE		
75	3003071	•	•	•	•	COPERCHIO	COVER	COUVERCLE	DECKEL	ENVOLVENTE		
76	3012164	•	•	•	•	TRASFORMATORE	TRANSFORMER	TRANSFORMATEUR	ZÜNDTRANSFORMATOR	TRANSFORMADOR		B
77	3013071	•	•	•	•	APPARECCHIATURA	CONTROL BOX	BOITE DE CONTROLE	STEUERGERÄT	CAJA CONTROL		B
78	3003891	•	•	•	•	RACCORDO PRESA ARIA	AIR PRESSURE SENSOR	GROUP RACCORD PRIS AIR	LUFTDRUCK SONDE	CONEXIÓN TOMA DEL AIRE		C
79	3005392	•	•	•	•	GUAINA	ARMATURE SLEEVE	GAIN E.V.	MV - HÜLSE	VÁLVULA		
80	3007081	•	•	•	•	GUARNIZIONE	SEAL	RONDELLE	METALLDICHTUNG	JUNTA		B
81	3012170	•	•	•	•	MENSOLA	BASE PLATE	PALQUE DE SUPPORT	GRUNDPLATTE	SOPORTE		
82	3003784	•	•	•	•	MORSETTIERA	CONTROL BOX BASE	SOCLE	STECKSOCKEL	ZÓCALO CAJA CONTROL		C
83	3002305	•	•	•	•	SOPPRESSORE	DAMPER	CONDENSATEUR	FUNKENTSTÖRUNG	SOPRESOR		
84	3003325	•	•	•	•	FERMO	SPRING LOCK	RESSORT D'APPUI	SICHERUNGSFEDER	DETENCIÓN		
85	3005444	•	•			GIRANTE	FAN	TURBINE	GEBLÄSERAD	TURBINA		C
85	3005460			•	•	GIRANTE	FAN	TURBINE	GEBLÄSERAD	TURBINA		C
86	3002280	•	•	•	•	FOTORESISTENZA	P.E. CELL	CELLULE	FOTOWIDERTAND	FOTORESISTENCIA		A
87	3006441	•	•	•	•	PRESA	HOLDER	PRISE CELLULE	SOCKEL	CONECTOR		C
88	3003362	•	•			BOCCA D'ASPIRAZIONE	AIR INTAKE	BOITIER D'ASPIRATION	ANSAUGÖFFNUNG	BOCA ASPIRACION		
88	3003363			•	•	BOCCA D'ASPIRAZIONE	AIR INTAKE	BOITIER D'ASPIRATION	ANSAUGÖFFNUNG	BOCA ASPIRACION		
89	3006022	•	•	•	•	GRUPPO RESISTENZA	HEATER GROUP	GROUPE RESISTANCE	HEIZWIDERSTAND	GRUPO RESISTENCIA		B
90	3003561	•	•	•	•	AVVIATORE	STARTER	DEMARREUR	ANLASSER	ARRANCADOR		C

N.	COD.	628 T		629 T		DESCRIZIONE	DESCRIPTION	DESCRIPTION	BESCHREIBUNG	DENOMINACION	MATRICOLA BRUCIATORE BURNER SERIAL NUMBER MATRICULE BRULEUR BRENNER KENN-NUMMER MATRICULA QUEMADORES	RICAMBI CONSIGLIATI ADVISED PARTS RECHANGE CONSEIL EMPFOHLENE ERSATZTEILE RECAMBIOS ACONSEJADOS
		3435023	3435024 *	3436023	3436024 *							
91	3003560		●			STAFFA	BRACKET	SUPPORT	TRAGERKONSOLE	SOPORTE		
91	3003577			●	●	STAFFA	BRACKET	SUPPORT	TRAGERKONSOLE	SOPORTE		
92	3003694	●	●	●	●	FILTRO	FILTER	FILTRE	FILTER	FILTRO		B
93	3007444	●	●	●	●	PRESSOSTATO ARIA	AIR PRESSURE SWITCH	PRESSOSTAT AIR	LUFTDRUCKWÄCHTER	PRESOSTATO DEL AIRE		A

\* = Versione Testa Lunga - Long Combustion Head Version - Version Tête Longue - Langer Brennkopf Ausführung - Versión alargado de tubo llama

\*\*

A = Ricambi per dotazione minima - Spare parts for minimum fittings - Pièces détachées pour équipement minimum - Ersatzteile für minimale Ausstattung - Recambios para equipamiento mínimo

A+B = Ricambi per dotazione base di sicurezza - Spare parts for basic safety fittings - Pièces détachées pour équipement standard de sécurité - Ersatzteile für Sicherheitsgrundausrüstung - Recambios para equipamiento básico de seguridad

A+B+C = Ricambi per dotazione estesa di sicurezza - Spare parts for extended safety fittings - Pièces détachées pour équipement complet de sécurité - Ersatzteile für erweiterte Sicherheitsausstattung - Recambios para equipamiento general de seguridad



---

**RIELLO**

RIELLO S.p.A.  
I-37045 Legnago (VR)  
Tel.: +39.0442.630111  
[http:// www.riello.it](http://www.riello.it)  
[http:// www.riello.com](http://www.riello.com)