

GB **Dual fuel kerosene and gas oil/gas burner**

Progressive two stage or modulating operation



B10

CODE	MODEL	TYPE
20034252	RLS 800/M MX	1301 T



Original instructions

1	Declarations	3
2	Information and general instructions	4
2.1	Information about the instruction manual	4
2.1.1	Introduction	4
2.1.2	General dangers	4
2.1.3	Other symbols	4
2.1.4	Delivery of the system and the instruction manual	5
2.2	Guarantee and responsibility	5
2.3	Guidance for the use of bio fuel blends up to 10%	6
2.3.1	Information and general instructions	6
2.3.2	Product Disclaimer Statement	6
3	Safety and prevention	7
3.1	Introduction	7
3.2	Safety warnings	7
3.3	Basic safety rules	7
3.4	Personnel training	7
4	Technical description of the burner	8
4.1	Burner designation	8
4.2	Models available	8
4.3	Burner categories - Countries of destination	8
4.4	Technical data	9
4.5	Electrical data	9
4.6	Overall dimensions	10
4.7	Firing rate	11
4.7.1	Modulation ratio	11
4.7.2	Test boiler	11
4.8	Burner description	12
4.9	Description of panel board	13
4.10	Burner equipment	13
5	Installation	14
5.1	Notes on safety for the installation	14
5.2	Handling	14
5.3	Preliminary checks	14
5.4	Installer/Service notes for the use of Gas oil with Bio blends up to 10%	15
5.5	Operation position	15
5.6	Removal of the locking screws from the shutter	15
5.7	Preparing the boiler	16
5.7.1	Boring the boiler plate	16
5.7.2	Blast tube length	16
5.8	Securing the burner to the boiler	16
5.9	Accessibility to the interior of the combustion head	17
5.10	Position of electrodes	17
5.11	Nozzle	18
5.11.1	Recommended nozzle	18
5.11.2	Nozzle assembly	18
5.12	Combustion head setting	19
5.13	Gas oil supply	20
5.13.1	Double-pipe circuit	20
5.13.2	The loop circuit	20
5.13.3	Single-pipe circuit	21
5.14	Hydraulic system layout	21
5.15	Hydraulic connections	22
5.16	Pump	22

5.16.1	Technical data.....	22
5.16.2	Pump priming.....	22
5.17	Pressure regulator	23
5.18	Gas feeding.....	24
5.18.1	Gas feeding line	24
5.18.2	Gas train	25
5.18.3	Gas train installation	25
5.18.4	Gas pressure	25
5.18.5	Pilot - gas train connection.....	26
5.18.6	Ignition pilot burner	26
5.19	Electrical wiring	27
5.19.1	Supply cables and external connections passage	27
5.20	Calibration of the thermal relay	28
6	Start-up, calibration and operation of the burner	29
6.1	Notes on safety for the first start-up.....	29
6.2	Adjustment before first firing (gas oil operation)	29
6.3	Burner firing	29
6.4	Fuel change	29
6.5	Adjustments before first firing (gas operation)	30
6.6	Burner starting	30
6.7	Burner firing	30
6.8	Servomotor	30
6.9	Fuel/combustion air adjustment	31
6.9.1	Maximum output	31
6.9.2	Minimum output	31
6.9.3	Intermediate outputs	31
6.10	Air/fuel ratio adjustment	32
6.10.1	Procedures for setting the burner	32
6.11	Adjustment pressure switches	33
6.11.1	Air pressure switch - CO check.....	33
6.11.2	Max. gas pressure switch	33
6.11.3	Min. gas pressure switch	33
6.12	Operation sequence of the burner	34
6.12.1	Burner starting	34
6.12.2	Steady state operation	34
6.12.3	Undesired shutdown during operation	34
6.12.4	Firing failure	34
6.13	Final checks (with burner operating).....	35
7	Maintenance	36
7.1	Notes on safety for the maintenance	36
7.2	Maintenance programme	36
7.2.1	Maintenance frequency.....	36
7.2.2	Checking and cleaning.....	36
7.3	Opening the burner	38
7.4	Closing the burner.....	38
8	Faults - Probable causes - Solutions	39
8.1	Light oil operation.....	40
8.2	Gas operation	42
A	Appendix - Accessories	44
B	Appendix - Electrical panel layout.....	46

1 Declarations

Declaration of conformity in accordance with ISO / IEC 17050-1

Manufacturer: RIELLO S.p.A.
 Address: Via Pilade Riello, 7
 37045 Legnago (VR)
 Product: Dual fuel kerosene and gas oil/ gas burner
 Model: RLS 800/M MX

These products are in compliance with the following Technical Standards:
 EN 676
 EN 267
 EN 12100
 and according to the European Directives:

GAD	2009/142/EC	Gas Devices Directive
MD	2006/42/EC	Machine Directive
LVD	2014/35/UE	Low Voltage Directive
EMC	2014/30/UE	Electromagnetic Compatibility

Such products are marked as follows:

 CE-0085CL0422

The quality is guaranteed by a quality and management system certified in accordance with ISO 9001:2015.

Manufacturer's Declaration

RIELLO S.p.A. declares that the following products comply with the NOx emission limits specified by German standard "1. BImSchV release 26.01.2010".

Product	Type	Model	Power
Dual fuel kerosene and gas oil/ gas burner	1301 T	RLS 800/M MX	1750 - 8000 kW

Legnago, 01.12.2015

Executive General Manager
 RIELLO S.p.A. - Burner Department
 Mr. U. Ferretti

Research & Development Director
 RIELLO S.p.A. - Burner Department
 Mr. F. Comencini

2 Information and general instructions

2.1 Information about the instruction manual

2.1.1 Introduction

The instruction manual supplied with the burner:

- is an integral and essential part of the product and must not be separated from it; it must therefore be kept carefully for any necessary consultation and must accompany the burner even if it is transferred to another owner or user, or to another system. If the manual is lost or damaged, another copy must be requested from the Technical Assistance Service of the area;
- is designed for use by qualified personnel;
- offers important indications and instructions relating to the installation safety, start-up, use and maintenance of the burner.

Symbols used in the manual

In some parts of the manual you will see triangular DANGER signs. Pay great attention to these, as they indicate a situation of potential danger.

2.1.2 General dangers

The **dangers** can be of **3 levels**, as indicated below.



Maximum danger level!
This symbol indicates operations which, if not carried out correctly, cause serious injury, death or long-term health risks.



This symbol indicates operations which, if not carried out correctly, may cause serious injury, death or long-term health risks.



This symbol indicates operations which, if not carried out correctly, may cause damage to the machine and/or injury to people.

2.1.3 Other symbols



DANGER: LIVE COMPONENTS
This symbol indicates operations which, if not carried out correctly, lead to electric shocks with lethal consequences.



DANGER: FLAMMABLE MATERIAL
This symbol indicates the presence of flammable materials.



DANGER: BURNING
This symbol indicates the risks of burns due to high temperatures.



DANGER: CRUSHING OF LIMBS
This symbol indicates the presence of moving parts: danger of crushing of limbs.



WARNING: MOVING PARTS
This symbol indicates that you must keep limbs away from moving mechanical parts; danger of crushing.



DANGER: EXPLOSION
This symbol signals places where an explosive atmosphere may be present. An explosive atmosphere is defined as a mixture - under atmospheric conditions - of air and flammable substances in the form of gases, vapours, mist or dust in which, after ignition has occurred, combustion spreads to the entire unburned mixture.



PERSONAL PROTECTION EQUIPMENT
These symbols indicate the equipment that must be worn and kept by the operator for protection against threats against safety and/or health while at work.



OBLIGATION TO ASSEMBLE THE HOOD AND ALL THE SAFETY AND PROTECTION DEVICES
This symbol signals the obligation to reassemble the hood and all the safety and protection devices of the burner after any maintenance, cleaning or checking operations.



ENVIRONMENTAL PROTECTION
This symbol gives indications for the use of the machine with respect for the environment.



IMPORTANT INFORMATION
This symbol indicates important information that you must bear in mind.

- This symbol indicates a list.

Abbreviations used

Ch.	Chapter
Fig.	Figure
Page	Page
Sec.	Section
Tab.	Table

2.1.4 Delivery of the system and the instruction manual

When the system is delivered, it is important that:

- the instruction manual is delivered to the user by the system manufacturer, with the recommendation to keep it in the room where the heat generator is to be installed.
- The instruction manual shows:
 - the serial number of the burner;

.....

- the address and telephone number of the nearest Assistance Centre.

.....

- The system supplier must carefully inform the user about:
 - the use of the system;
 - any further tests that may be required before activating the system;
 - maintenance, and the need to have the system checked at least once a year by a representative of the manufacturer or another specialised technician.
 To ensure a periodic check, the manufacturer recommends the drawing up of a Maintenance Contract.

2.2 Guarantee and responsibility

The manufacturer guarantees its new products from the installation date, in accordance with the regulations in force and/or the sales contract. At the moment of the first start-up, check that the burner is integral and complete.



WARNING

Failure to observe the information given in this manual, operating negligence, incorrect installation and carrying out of non authorised modifications will result in the annulment by the manufacturer of the guarantee that it supplies with the burner.

In particular, the rights to the guarantee and the responsibility will no longer be valid, in the event of damage to things or injury to people, if such damage/injury was due to any of the following causes:

- incorrect installation, start-up, use and maintenance of the burner;
- improper, incorrect or unreasonable use of the burner;
- intervention of unqualified personnel;
- carrying out of unauthorised modifications on the equipment;
- use of the burner with safety devices that are faulty, incorrectly applied and/or not working;
- installation of untested supplementary components on the burner;
- powering of the burner with unsuitable fuels;
- faults in the fuel supply system;
- continuation of use of the burner when a fault has occurred
- repairs and/or overhauls incorrectly carried out;
- modification of the combustion chamber with inserts that prevent the regular development of the structurally established flame;
- insufficient and inappropriate surveillance and care of those burner components most likely to be subject to wear and tear;
- the use of non-original components, including spare parts, kits, accessories and optional;
- force majeure.

The manufacturer furthermore declines any and every responsibility for the failure to observe the contents of this manual.

Riello warranty is subject to correct burner, appliance and application matching, and set up in line with Riello's instructions and guidelines. All components within the hydraulic circuit suitable for bio fuel use and supplied by Riello will be identified as Bio compatible. No warranty is given in relation to the use of components which are not so identified with bio fuel blends. If in any doubt please contact Riello for further advice.

If any Riello burners are used with fuel with a bio content >10% then the components within the hydraulic circuit maybe affected and are not covered under warranty. The hydraulic circuit consists of;

- Pump
- Hydraulic ram (where applicable)
- Valve block
- Flexible oil lines (considered as a consumable component)

1. Irrespective of any warranty given by Riello in relation to normal use and manufacturing defects, when fuels not meeting the relevant standards are used, or where fuel storage issues have not been addressed correctly, or the equipment used is not compatible, if failures occur which are directly or indirectly attributed to such issues and/or to the non-observance of this guidance, then no warranty or liability is implied or accepted by Riello.
2. Riello have carefully chosen the specification of the bio compatible components including the flexible oil lines to protect the pump, safety valve and nozzle. The Riello warranty is dependent upon the use of Riello genuine components including the oil lines, being used.
3. Riello warranty does not cover defects arising from incorrect commissioning or servicing by non Riello employed service engineers, and any issues impacting the burner arising from external site related issues.

2.3 Guidance for the use of bio fuel blends up to 10%

Background

With increasing focus on renewable and sustainable energy requirements, Bio fuel usage is set to increase. Riello is committed to promoting energy conservation and the use of renewable energy from sustainable resources including liquid bio fuels, however there are some technical aspects that must be considered at the planning stage of using such fuels to reduce the potential for equipment failure or the risks of fuel leakage.

Liquid Bio fuel is a generic description used for oil that can come from numerous feed stocks including recycled cooking oils. These types of oils have to be considered and treated differently from standard mineral or fossil fuels, as they are generally more acidic, hygroscopic and less stable.

Due to this, a holistic approach is needed from the specification of the liquid Bio fuel, the storage of the fuel, its oil supply line and ancillary equipment, and very importantly the oil filtration and the burner itself. The specification for FAME (Fatty Acids Methyl Ester) liquid Bio fuel is critical to reliable equipment operation.

It is a minimum requirement that the fuel blend (up to 10% Bio) is obtained with gasoil in accordance with the relevant EN standards, regional regulations and FAME in accordance with EN 14214. It is also important that the fuel blends meet the requirements related to operational environment conditions within the relevant EN standards.

When choosing your Riello oil products where you know Bio fuels will be in use, please make sure that a Bio compatible burner and/or components have been supplied. If an existing burner is to be used with a liquid Bio fuel then a kit may be required to make it compatible and the guidance notes enclosed concerning oil storage and filtration must be adhered to. The end user is responsible for the thorough verification of the potential risks associated with the introduction of a bio fuel blend and the suitability of the appliances and installation applicable.

Irrespective of any warranty given by Riello in relation to normal use and manufacturing defects, when fuels not meeting the relevant standards are used, or where fuel storage issues have not been addressed correctly, or the equipment used is not compatible, if failures occur which are directly or indirectly attributed to such issues and/or to the non-observance of this guidance, then no warranty or liability is implied or accepted by Riello.

2.3.1 Information and general instructions

To ensure consistency, the supplier of the fuel must be able to demonstrate compliance with a recognised Quality Control and management system to ensure high standards are maintained within the storage, blending and delivery processes. The installation oil storage tank and its ancillaries must also be prepared BEFORE liquid Bio fuel is introduced. Checks and preparation should include;

- For new installations, make sure that all materials and seals in the oil storage and supply line to the burner are compatible with Bio fuels. For all installations, there must be a good quality bio compatible oil filter at the tank and then a secondary filter of 100 Microns protecting the burner from contamination.
- If an existing oil storage tank is to be used then in addition to the materials checks as detailed above, it will be essential that the tank is first inspected for condition and checked for water or other contamination. Riello strongly recommends that the tank is cleaned and oil filters replaced prior to Bio fuel delivery. If this is not completed then due to the hygroscopic nature of Bio fuel, it will effectively clean the tank, absorb water present which in turn will result in equipment

failure that is not covered by the manufacturer's warranty.

- Depending on the capacity of the oil storage tank and oil usage, fuels may remain static within the tank for some considerable time and so Riello recommends that the oil distributor is consulted regarding the use of additional Biocides within the fuel to prevent microbial growth from occurring within the tank. Riello suggests that fuel suppliers and or service companies are contacted for guidance on fuel filtration. Special attention should be applied to fuel applications where oil may be stored for long periods of time.
- The burner must be set according to the appliance application and commissioned checking that all combustion parameters are as recommended in the appliance technical manual.
- Riello recommends that the in line and burner oil pump filters are inspected and if required replaced at least every 4 months during burner use, before the burner start-up following a long period of discontinue operation and even more frequently where contamination has occurred. Particular attention is needed when inspecting and checking for fuel leakages from seals, gaskets and hoses.

2.3.2 Product Disclaimer Statement

CAREFULLY READ THE FOLLOWING DISCLAIMER. YOU ACCEPT AND AGREE TO BE BOUND BY THIS DISCLAIMER BY PURCHASING RIELLO BIO COMPATIBLE BURNERS AND/OR COMPONENTS.

Although the information and recommendations (hereinafter "Information") in this guidance is presented in good faith, believed to be correct and has been carefully checked, Riello (and its subsidiaries) makes no representations or warranties as to the completeness or accuracy of the Information. Information is supplied upon the condition that the persons receiving same will make their own determination as to its suitability for their purposes prior to use. In no event will Riello (and its subsidiaries) be responsible for damages of any nature whatsoever resulting from the use of or reliance upon Information.

Other than set forth herein, Riello (and its subsidiaries) makes no additional warranties with respect to the bio compatible burner, either express or implied, including that of merchantability or fitness for a particular purpose or use.

In no event shall Riello (and its subsidiaries) be liable for any indirect, incidental, special or consequential damages including, without limitation, loss of profits, damages for loss of business profits, business interruption, loss of business information, loss of equipment, or other pecuniary loss or compensation for services whether or not it is advised of the possibility of such damages.

With the exception of injuries to persons, Riello's liability is limited to the customer's right to return defective/non-conforming products as provided by the relevant product warranty.

3 Safety and prevention

3.1 Introduction

The burners have been designed and built in compliance with current regulations and directives, applying the known technical rules of safety and envisaging all the potential danger situations.

It is necessary, however, to bear in mind that the imprudent and clumsy use of the equipment may lead to situations of death risk for the user or third parties, as well as the damaging of the burner or other items. Inattention, thoughtlessness and excessive confidence often cause accidents; the same applies to tiredness and sleepiness.

It is a good idea to remember the following:

- The burner must only be used as expressly described. Any other use should be considered improper and therefore dangerous.

In particular:

it can be applied to boilers operating with water, steam, diathermic oil, and to other uses expressly named by the manufacturer; the type and pressure of the fuel, the voltage and frequency of the electrical power supply, the minimum and maximum deliveries for which the burner has been regulated, the pressurisation of the combustion chamber, the dimensions of the combustion chamber and the room temperature must all be within the values indicated in the instruction manual.

- Modification of the burner to alter its performance and destinations is not allowed.
- The burner must be used in exemplary technical safety conditions. Any disturbances that could compromise safety must be quickly eliminated.
- Opening or tampering with the burner components is not allowed, apart from the parts requiring maintenance.
- Only those parts detailed as available as spare parts by the Manufacturer can be replaced.

3.2 Safety warnings

The dimension of the boiler's combustion chamber must respond to specific values, in order to guarantee a combustion with the lowest polluting emissions rate.

The Technical Service Personnel will be glad to give you all the information for a correct matching of this burner to the boiler.

This burner must only be used for the application it was designed for.

The manufacturer accepts no liability within or without the contract for any damage caused to people, animals and property due to installation, adjustment and maintenance errors or to improper use.

3.3 Basic safety rules

- Children or inexperienced persons must not use the appliance.
- Under no circumstances must the intake grids, dissipation grids and ventilation vents in the installation room be covered up with cloths, paper or any other material.
- Unauthorised persons must not attempt to repair the appliance.
- It is dangerous to pull or twist the electric leads.
- Cleaning operations must not be performed if the appliance is not disconnected from the main power supply.
- Do not clean the burner or its parts with inflammable substances (e.g. petrol, alcohol, etc.). The cover must be cleaned with soapy water.
- Do not place anything on the burner.
- Do not block or reduce the size of the ventilation vents in the installation room.
- Do not leave containers and inflammable products or combustible materials in the installation room.

3.4 Personnel training

The user is the person, body or company that has acquired the machine and intends to use it for the specific purpose. He is responsible for the machine and for the training of the people working around it.

The user:

- undertakes to entrust the machine exclusively to suitably trained and qualified personnel;
- must take all the measures necessary to prevent unauthorised people gaining access to the machine;
- undertakes to inform his personnel in a suitable way about the application and observance of the safety instructions. With that aim, he undertakes to ensure that everyone knows the use and safety instructions for his own duties;
- must inform the manufacturer if faults or malfunctioning of the accident prevention systems are noticed, along with any presumed danger situation.
- Personnel must always use the personal protective equip-

ment envisaged by legislation and follow the indications given in this manual.

- Personnel must observe all the danger and caution indications shown on the machine.
- Personnel must not carry out, on their own initiative, operations or interventions that are not within their province.
- Personnel must inform their superiors of every problem or dangerous situation that may arise.
- The assembly of parts of other makes, or any modifications, can alter the characteristics of the machine and hence compromise operating safety. The manufacturer therefore declines any and every responsibility for any damage that may be caused by the use of non-original parts.

4 Technical description of the burner

4.1 Burner designation

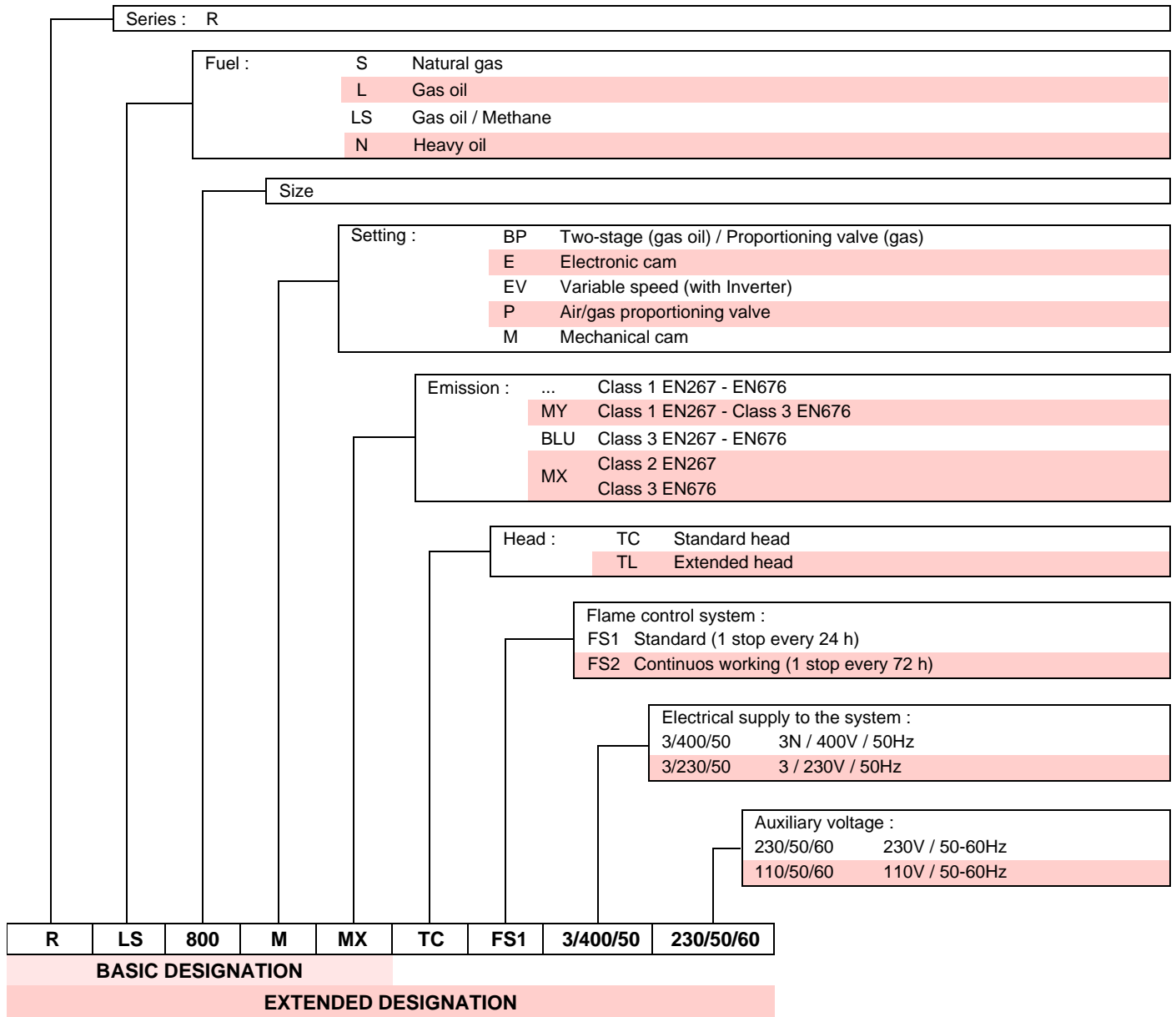

4.2 Models available

Designation	Electrical supply	Starting	Code
RLS 800/M MX	3/400/50	Star/Delta	20034252

4.3 Burner categories - Countries of destination

Country of destination	Gas category
SE - FI - AT - GR - DK - ES - GB - IT - IE - PT - IS - CH - NO	I _{2H}
DE	I _{2ELL}
NL	I _{2L} - I _{2E} - I ₂ (43,46 ÷ 45,3 MJ/m ³ (0°C))
FR	I _{2Er}
BE	I _{2E(R)B}
LU - PL	I _{2E}

4.4 Technical data

Model			RLS 800/M MX
Type			1301 T
Output (1)	MIN - MAX	kW	1750/3500 ÷ 8000
Delivery (1)		kg/h	147/295 ÷ 674
Fuel			Gas oil and Blends of gas oil and bio fuel (FAME in accordance with EN 14214) up to 10%
Kerosene	net calorific value	kWh/kg	11.97
		Mcal/kg	10.3 (10.300 kcal/kg)
	density	kg/dm ³	0.77 - 0.83
	viscosity at 20 °C	mm ² /s max	6 (1.5 °E - 6 cSt)
Gas oil	net calorific value	kWh/kg	11.86
		Mcal/kg	10.2 (10.200 kcal/kg)
	density	kg/dm ³	0.82 - 0.85
	viscosity at 20 °C	mm ² /s max	6 (1.5 °E - 6 cSt)
Natural gas			- G20 (methane) - G21 - G22 - G23 - G25 - GPL: G31 - PCI 26 kWh/Nm ³
Gas pressure at maximum delivery (2) - Gas: G20/G25		mbar	50.6/75.4
Operation			- Intermittent (min. 1 stop in 24 hours) - Progressive two-stage or modulating by kit (see accessoires)
Nozzles		number	1
Standard applications			Boilers: water, steam, diathermic oil
Room temperature		°C	0 - 50
Combustion air temperature		°C max	60
Pump	delivery (at 16,5 bar)	kg/h	560
	pressure range	bar	6 - 30
	fuel temperature	°C max	140
Noise level (3)	Sound pressure	dB (A)	89,6
	Sound power		103,9
Weight		kg	320

Tab. A

- (1) Reference conditions: Ambient temperature 20°C - Gas temperature 15°C - Barometric pressure 1013 mbar - Altitude 0 m a.s.l.
 (2) Pressure at test point 5)(Fig. 4) with zero pressure in the combustion chamber and maximum burner output.
 (3) Sound pressure measured in manufacturer's combustion laboratory, with burner operating on test boiler and at maximum rated output. The sound power is measured with the "Free Field" method, as per EN 15036, and according to an "Accuracy: Category 3" measuring accuracy, as set out in EN ISO 3746.

4.5 Electrical data

Model			RLS 800/M MX
Electrical supply			3N ~ 400V +/-10% 50 Hz
Fan motor IE2		rpm	2964
		V	400/690
		kW	21
		A	41.8/24.2
Pump motor IE2		rpm	2870
		V	220-240/380-415
		kW	1.5
		A	5.9/3.4
Ignition transformer		V1 - V2 I1 - I2	230 V - 1 x 5 kV 1 A - 20 mA
Electrical power consumption	Gas oil	kW max	24.8
	Gas		23
Protection level			IP 54

Tab. B

Model			RLS 800/M MX
Electrical supply			3N ~ 400V +/-10% 50 Hz
Fan motor IE3	rpm		2880
	V		400/690
	kW		22
	A		38.2/22.3
Pump motor IE3	rpm		2890
	V		220-240/380-415
	kW		1,5
	A		5.9/3.4
Ignition transformer		V1 - V2 I1 - I2	230 V - 1 x 5 kV 1 A - 20 mA
Electrical power consumption	Gas oil	kW max	25.8
	Gas		24
Protection level			IP 54

Tab. C

4.6 Overall dimensions

The maximum dimensions of the burner are given in Fig. 1. Bear in mind that inspection of the combustion head requires the burner to be opened by rotating the rear part on the hinge.

The overall dimensions of the burner when open are indicated by L and R.

Position I is a reference for the thickness of the boiler door refractory fettling.

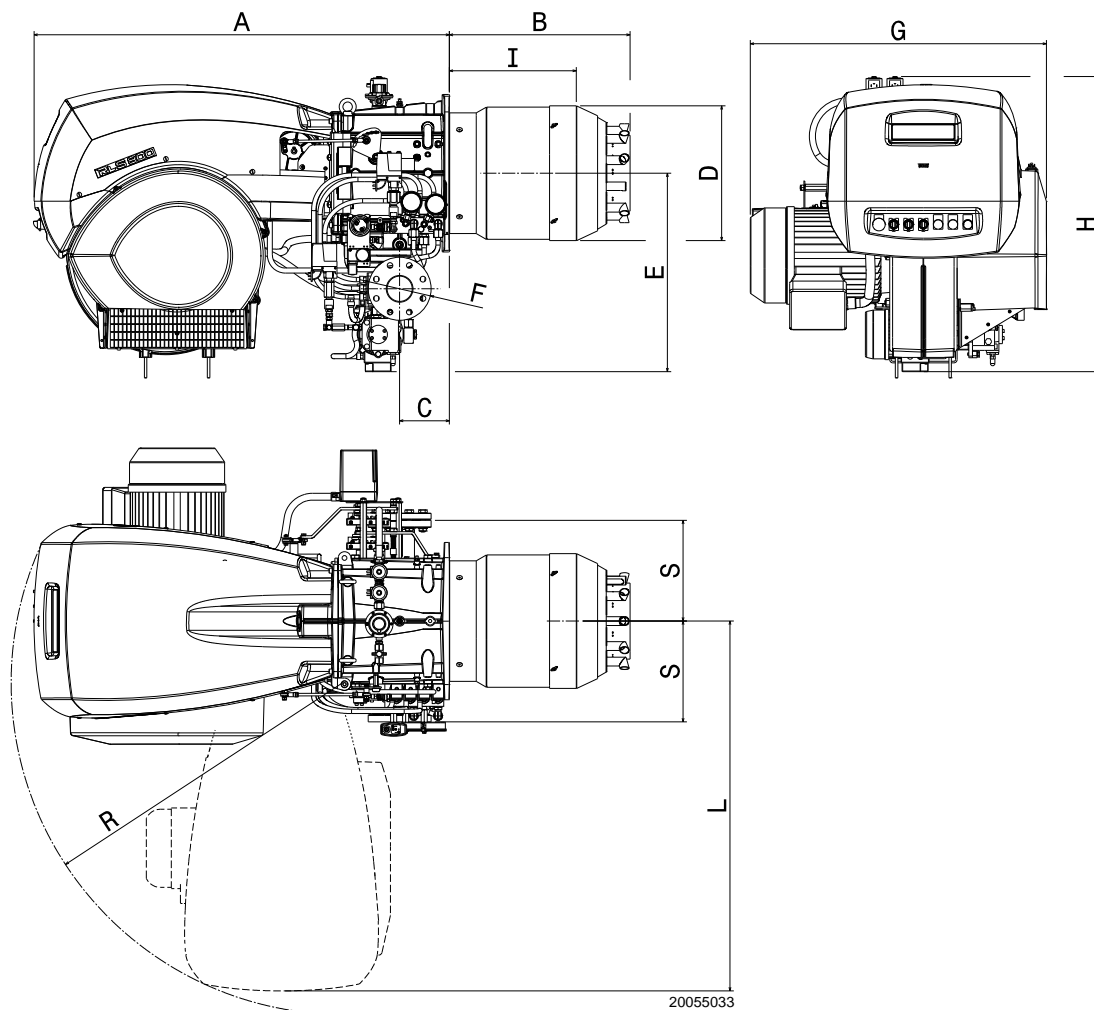

Fig. 1

mm	A	B	C	D	E	F	G	H	I	L	R	S
RLS 800/M MX	1325	575	164	428	630	DN80	940	937	405	1190	1055	320

Tab. D

4.7 Firing rate

Maximum output must be selected in the hatched area of the diagram (Fig. 2).

Minimum output must not be lower than the minimum limit shown in the diagram:

RLS 800/M MX = 1750 kW



The firing rate area values (Fig. 2) have been obtained considering a surrounding temperature of 20 °C, and an atmospheric pressure of 1013 mbar (approx. 0 m above sea level) and with the combustion head adjusted as shown on page 19.

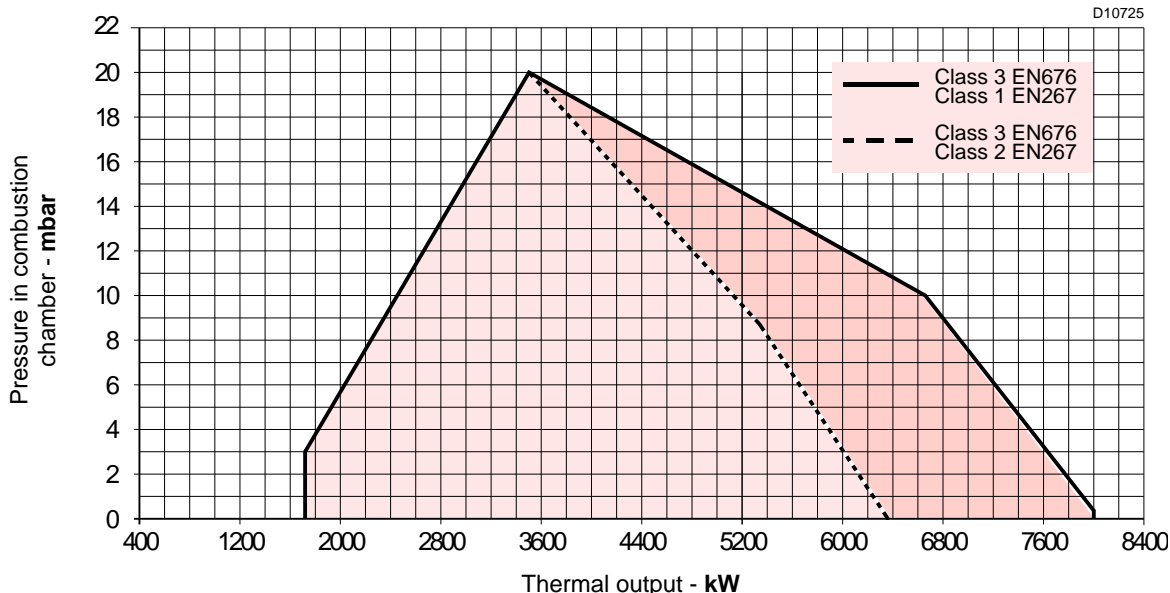

Fig. 2

4.7.1 Modulation ratio

The modulation ratio, determined using test boilers according to standard (EN 676 for gas, EN 267 for gas oil), is 2.4 : 1.

4.7.2 Test boiler

The burner/boiler matching does not pose any problems if the boiler is CE type-approved and its combustion chamber dimensions are similar to those indicated in diagram (Fig. 3).

If the burner must be combined with a boiler that has not been CE type-approved and/or its combustion chamber dimensions are clearly smaller than those indicated in diagram (Fig. 3), consult the manufacturer.

The firing rates were set in relation to special test boilers, according to EN 676 regulations.

Fig. 3 indicates the diameter and length of the test combustion chamber.

Example:
Output 7000 kW - diameter 120 cm - length 6m.

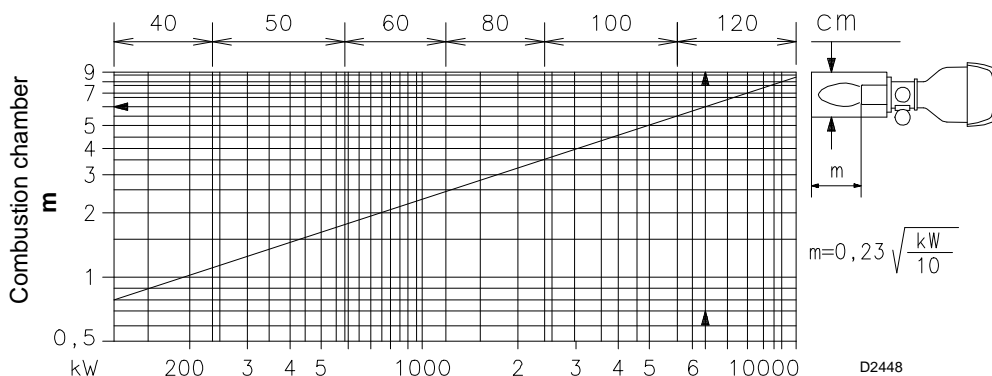

Fig. 3

4.8 Burner description

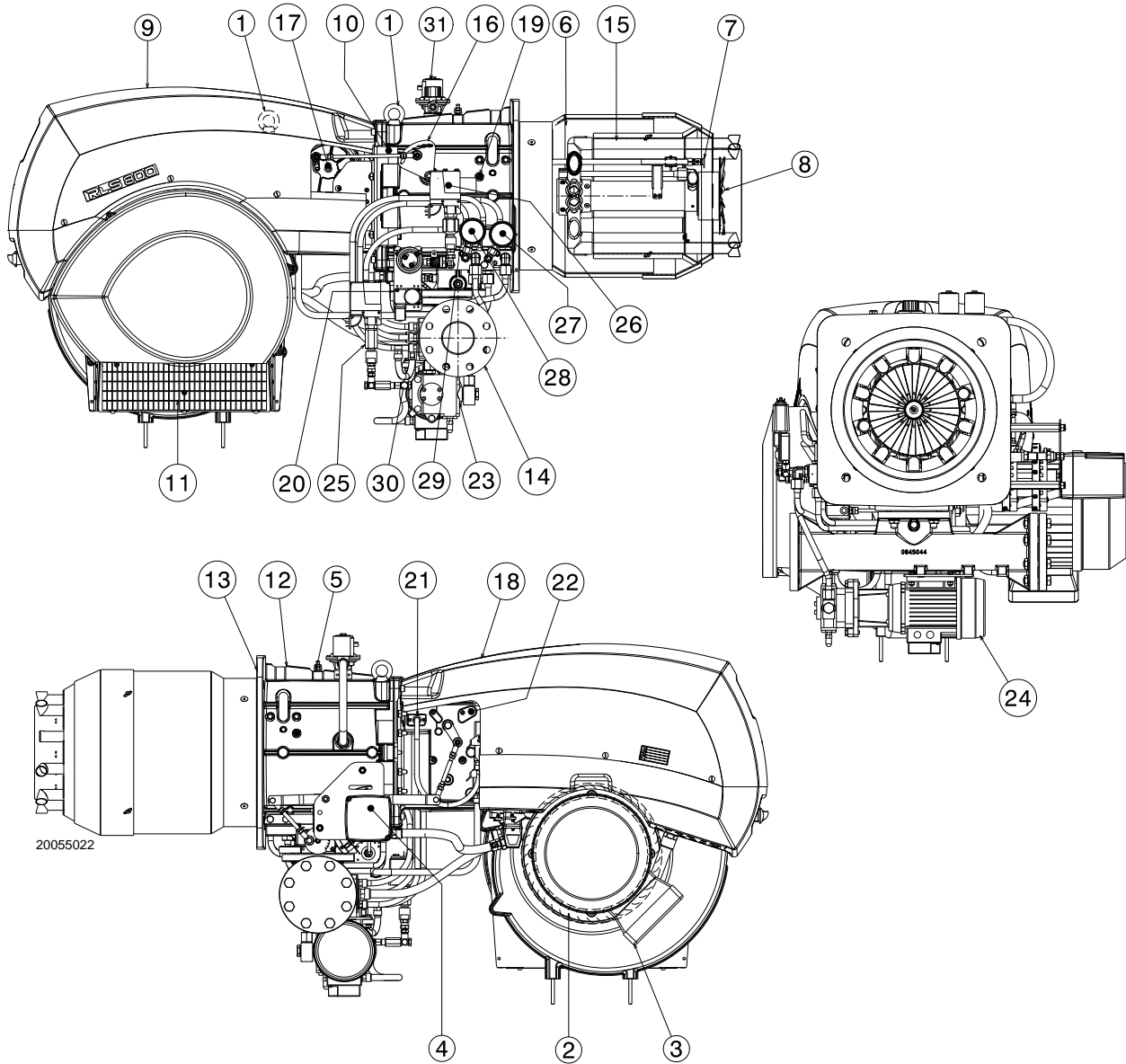

Fig. 4

- | | |
|--|---|
| 1 Lifting eyebolts | 24 Pump motor |
| 2 Fan | 25 Minimum oil pressure switch |
| 3 Fan motor | 26 Maximum oil pressure switch |
| 4 Servomotor | 27 Pressure gauge for pressure on nozzle return |
| 5 Gas pressure test point | 28 Nozzle delivery pressure gauge |
| 6 Combustion head | 29 Oil modulator |
| 7 Ignition pilot | 30 Pressure gauge attachment |
| 8 Flame stability disk | 31 Pilot gas train |
| 9 Electric panel board - cover | |
| 10 Hinge for opening burner | |
| 11 Air inlet to fan | |
| 12 Manifold | |
| 13 Thermal insulation screen for securing burner to boiler | |
| 14 Gas train flange | |
| 15 Shutter | |
| 16 Lever for movement of combustion head | |
| 17 Gears for movement of air damper | |
| 18 Air pressure switch (differential operating type) | |
| 19 Air pressure test point | |
| 20 Maximum gas pressure switch with pressure test point | |
| 21 UV photocell | |
| 22 Air pressure test point pressure test point "+" | |
| 23 Pump | |



The burner can be opened either on the right or left sides, irrespective of the side from which fuel is supplied.

When the burner is closed, the hinge can be re-positioned on the opposite side.

4.9 Description of panel board

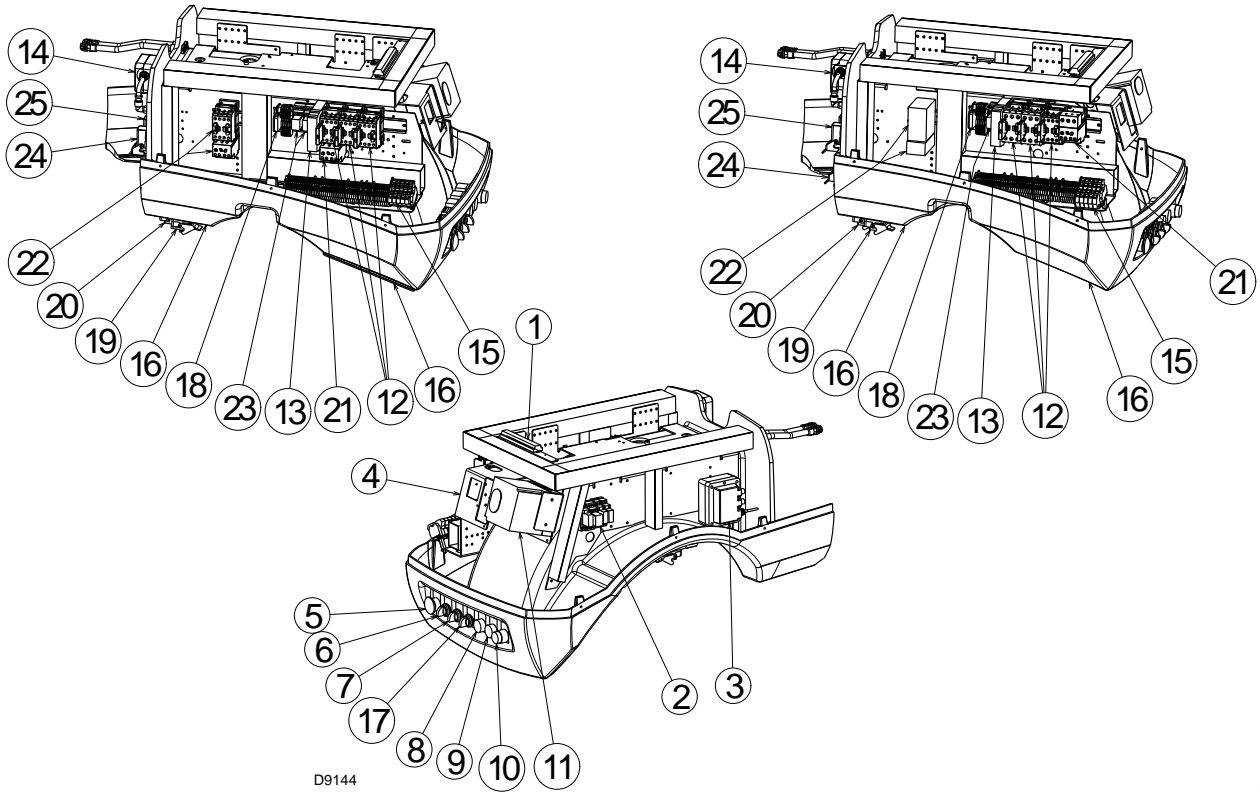

Fig. 5

- 1 Terminal strip for kits
- 2 Relay outlet - clean contacts
- 3 Ignition transformer
- 4 Bracket for mounting the power regulator RWF
- 5 Stop push-button
- 6 Dial for off - automatic - manual
- 7 Power dial for increase - decrease of power
- 8 Start enabled light
- 9 Motor thermal cutout tripped warning light
- 10 Signal light for burner failure and lock-out reset button
- 11 Control box
- 12 Star-powered/delta-powered starter
- 13 Timer
- 14 Air pressure switch
- 15 Main supply terminal strip
- 16 Entry for power cables and external leads
- 17 Fuel selector and remote fuel selector enabling
- 18 Auxiliary circuits fuse

- 19 Servomotor plug/socket
- 20 Plug-socket valve /Pump motor
- 21 Fan motor thermal cut-out
- 22 Pump motor contactor and thermal cut-out
- 23 Oil/gas selection relay
- 24 Plug-socket maximum gas pressure switch
- 25 Plug-socket flame sensor

NOTE

Two types of burner failure may occur:

- **Control box lock-out:** if the control box 11)(Fig. 5) pushbutton (**red led**) and the reset button 10)(Fig. 5) light up, it indicates that the burner is in lock-out. To reset, press the pushbutton 10)(Fig. 5).
- **Motors trip:** release by pressing the push button on thermal.

4.10 Burner equipment

Flange gasket	No. 1
Flange fixing screws M16x50	No. 8
Thermal screen	No. 1
Screws M18x70 to secure the burner flange to the boiler	No. 4
Spacers (see Fig. 15)	No. 2
Instruction	No. 1
Spare parts	No. 1



WARNING

In case of use with gas oil containing up to 10% Bio blend, it will be essential to use flexible oil lines suitable for bio fuel use. Please contact Riello for further information.

5 Installation

5.1 Notes on safety for the installation

After carefully cleaning all around the area where the burner will be installed, and arranging the correct lighting of the environment, proceed with the installation operations.



All the installation, maintenance and disassembly operations must be carried out with the electricity supply disconnected.



The installation of the burner must be carried out by qualified personnel, as indicated in this manual and in compliance with the standards and regulations of the laws in force.

5.2 Handling

The packaging of the burner includes a wooden platform, so it is possible to move the burner (still packaged) with a transpallet truck or fork lift truck.



The handling operations for the burner can be highly dangerous if not carried out with the greatest attention: keep any unauthorised people at a distance; check the integrity and suitability of the available means of handling. Check also that the area in which you are working is empty and that there is an adequate escape area (i.e. a free, safe area to which you can quickly move if the burner should fall). During the handling, keep the load at not more than 20-25 cm from the ground.



After positioning the burner near the installation point, correctly dispose of all residual packaging, separating the various types of material.



Before proceeding with the installation operations, carefully clean all around the area where the burner will be installed.

5.3 Preliminary checks

Checking the consignment



After removing all the packaging, check the integrity of the contents. In the event of doubt, do not use the burner; contact the supplier.



The packaging elements (wooden cage or cardboard box, nails, clips, plastic bags, etc.) must not be abandoned as they are potential sources of danger and pollution; they should be collected and disposed of in the appropriate places.

RBL	A	B	C
D	E		F
GAS/KASU <input checked="" type="checkbox"/>	G		H
GAZ/AEFO	G		H
I			
HEZÖ/FUE	L		
RIELLO SpA I-37045 Legnago (VR)			CE 0085

D9243

Fig. 6

Checking the characteristics of the burner

- Check the identification label of the burner, showing:
- the model (A)(Fig. 6) and type of burner (B);
 - the year of manufacture, in cryptographic form (C);
 - the serial number (D);
 - the data for electrical supply and the protection level (E);
 - the electrical input power (F);
 - the types of gas used and the relative supply pressures (G);
 - the data of the burner's minimum and maximum output possibilities (H) (see Firing rate)
- Warning.** The output of the burner must be within the boiler's firing rate;
- the category of the device/countries of destination (I).
 - gas oil (L) max. viscosity.



A burner label that has been tampered with, removed or is missing, along with anything else that prevents the definite identification of the burner makes any installation or maintenance work difficult.

5.4 Installer/Service notes for the use of Gas oil with Bio blends up to 10%

- During the burner installation, check that the gasoil and bio fuel blends are in accordance with Riello specifications (please refer to the chapters "Technical Data" and "Guidance for the use of bio fuel blends up to 10%" within the burner technical manual).
- If a Bio blend is in use the installer must seek information from the end user that their fuel supplier can evidence that the blends of fuel conform to the relevant standards.
- Check that the materials used in the construction of the oil tank and ancillary equipment are suitable for bio fuels, If not these must be upgraded or replaced with Bio compatible parts.
- Particular attention should be given to the oil storage tank and supply to the burner. Riello recommends that existing oil storage tanks are cleaned, inspected and any traces of water are removed BEFORE bio fuel is introduced (Contact the tank manufacturer or oil supplier for further advice). If these recommendations are not respected this will increase the risk of contamination and possible equipment failure.
- In line oil filters should be replaced making sure that they are Bio compatible. Riello recommends a good quality bio compatible oil filter at the tank and a secondary 100 micron filter are used to protect the burner pump and nozzle from contamination.
- The burner hydraulic components and flexible oil lines must be suitable for bio fuel use (check with Riello if in doubt). Riello have carefully chosen the specification of the bio compatible components including the flexible oil lines to protect the pump, safety valve and nozzle. The Riello warranty is dependent upon the use of Riello genuine components including the oil lines, being used. The burner must be commissioned and combustion parameters set to appliance manufacturer's recommendations.
- Regularly check visually for any signs of oil leakage from seals, gaskets and hoses.
- It is strongly recommended that with Bio fuel use, oil filters are inspected and replaced every 4 months. More regularly where contamination is experienced.
- During extended periods of non operation and/or where burners are using oil as a standby fuel, it is strongly recommended that the burner is put into operation for shorts periods at least every three months.

5.5 Operation position

The burner is designed to work only in the positions 1, 2, 3 and 4. Installation 1 is preferable, as it is the only one that allows performing maintenance operations as described in this manual. Installations 2, 3 and 4 permit operation but make maintenance and inspection of the combustion head difficult.



Any other position could compromise the correct working of the appliance.

Installation 5 is prohibited for safety reasons.

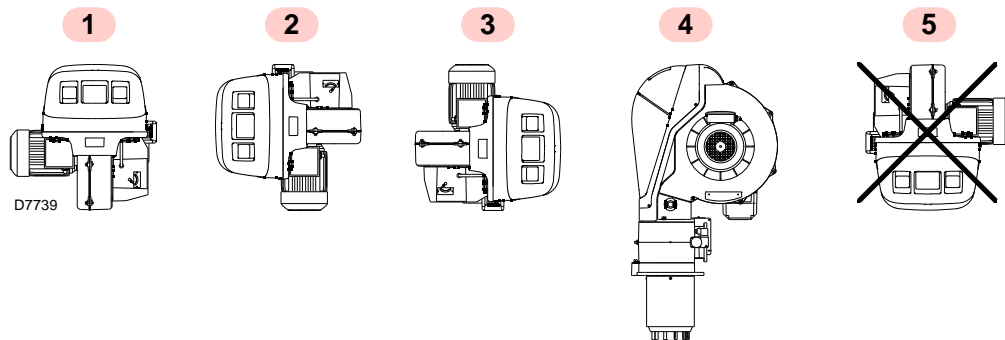

Fig. 7

5.6 Removal of the locking screws from the shutter



Remove the screws and the nuts 1)-2)(Fig. 8), before installing the burner on the boiler.

Replace them with the screws 3) M12 X 25 supplied with the burner.

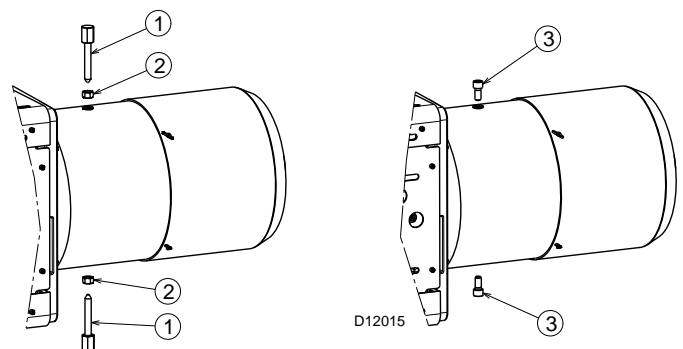

Fig. 8

5.7 Preparing the boiler

5.7.1 Boring the boiler plate

Drill the combustion chamber locking plate as shown in Fig. 9.
The position of the threaded holes can be marked using the thermal screen supplied with the burner.

5.7.2 Blast tube length

The length of the blast tube must be selected according to the indications provided by the manufacturer of the boiler, and in any case it must be greater than the thickness of the boiler door complete with its fettling.

For boilers with front flue passes 1)(Fig. 10) or flame inversion chambers, protective fettling in refractory material 5) must be inserted between the boiler fettling 2) and the blast tube 4).

This protective fettling must not compromise the extraction of the blast tube.

For boilers having a water-cooled front the refractory fettling 2)-5)(Fig. 10) is not required unless it is expressly requested by the boiler manufacturer.

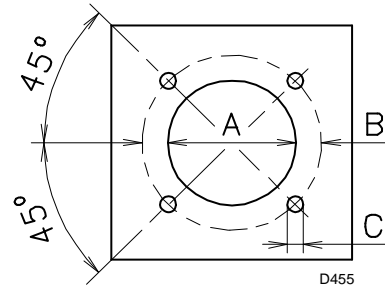

Fig. 9

mm	A	B	C
RLS 650/M MX	440	495	M 18

Tab. E

5.8 Securing the burner to the boiler

Prepare an adequate system of hoisting by hooking onto the rings 3)(Fig. 10).

- Slip the thermal protection (standard equipment) onto the blast tube 4)(Fig. 10).
- Place entire burner on the boiler hole arranged previously, (Fig. 9), and fasten with the screws given as standard equipment.



The burner-boiler seal must be airtight.

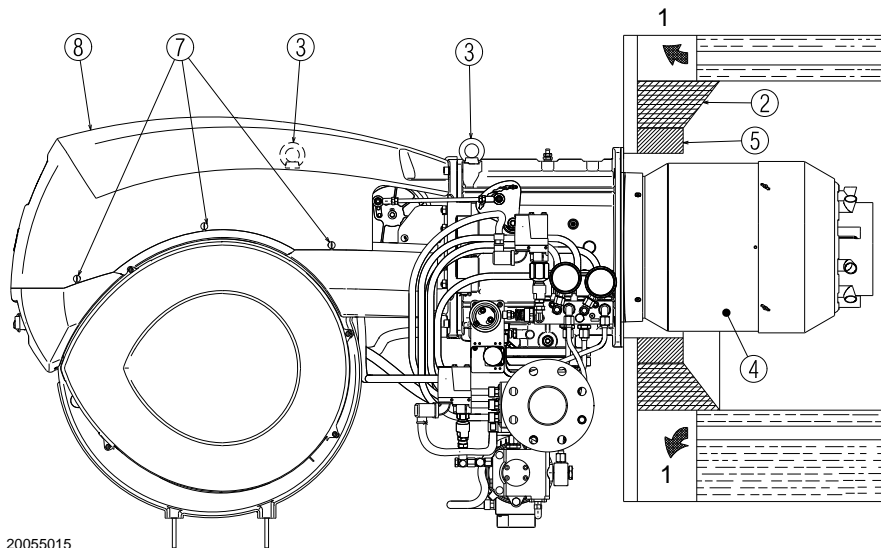

Fig. 10

5.9 Accessibility to the interior of the combustion head

- In order to reach inside the combustion head proceed as follows:
- disconnect the electrical wiring related to oil pump/servomotor, air servomotor and gas pressure switch;
 - disconnect the leverages related to air damper and head movement;
 - unscrew the 4 x fixing screws 1)(Fig. 11);
 - Release the cable of the electrode 2);
 - Disconnect the oil pipes by unscrewing the two connectors 3).

- Release the ignition pilot retainer;
- Remove the screw/gas pressure test point 6) of the combustion head;
- unscrew the under part of the elbow until it comes free of its slot;
- Extract the internal part 5) of the combustion head.



While unscrewing, some fuel may leak out.

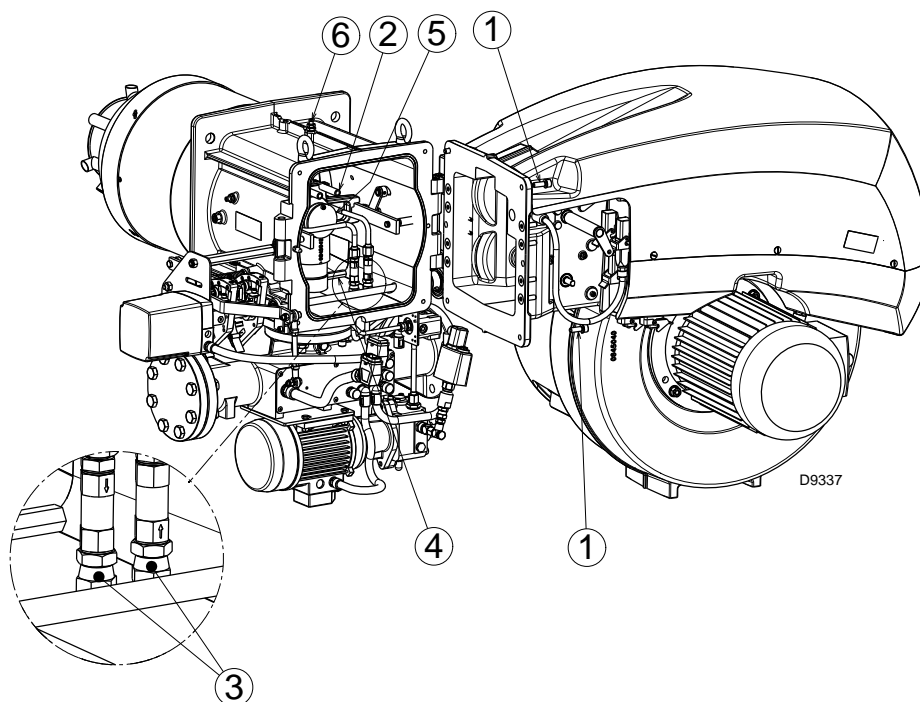

Fig. 11

5.10 Position of electrodes



Place the electrode on the ignition pilot observing the dimensions specified in Fig. 12.

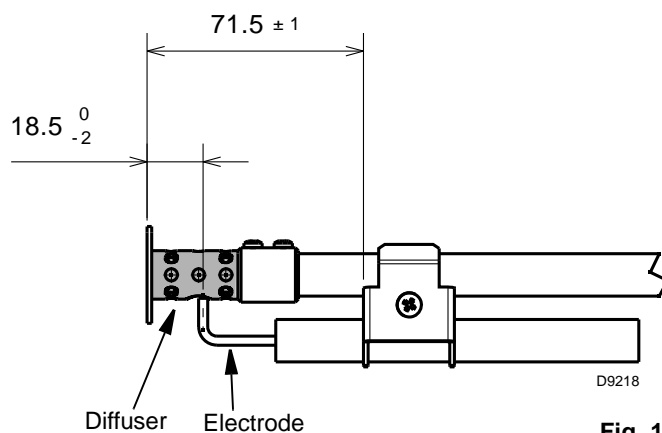

Fig. 12

5.11 Nozzle

The burner complies with the emission requirements of the EN 267 standard.

In order to guarantee that emissions do not vary, recommended and/or alternative nozzles specified by Riello in the Instruction and warning booklet should be used.



WARNING

It is advisable to replace nozzles every year during regular maintenance operations.



CAUTION

The use of nozzles other than those specified by Riello S.p.A. and inadequate regular maintenance may result into emission limits non-conforming to the values set forth by the regulations in force, and in extremely serious cases, into potential hazards to people and objects.

The manufacturing company shall not be liable for any such damage arising from nonobservance of the requirements contained in this manual.

5.11.1 Recommended nozzle

- Bergonzo type B5 45°
- Fluidics type N4 45°

Intermediate flow rates may be obtained by choosing the nozzle with a nominal flow rate slightly higher than that actually required.

Complete range of nozzles:

- **Bergonzo type B5 45°:**
350 - 375 - 400 - 425 - 450 - 475 - 500 - 525 - 550 - 575 - 600 - 650 - 700 - 750. We normally recommend 45° angles of pulverisation.

kg/h	Delivery pressure bar	Return pressure bar	kg/h	kW
375	20	11.5	147	1750
	20	17	295	3500
550	20	10	170	2000
	20	17	421	5000
650	20	8	180	2150
	20	16.5	565	6650
750	25	11.5	227	2700
	25	20.5	675	8000

Tab. F

- **Fluidics type N4 45°:**
375 - 400 - 450 - 500 - 550 - 600 - 650 - 700 - 750. We normally recommend 45° angles of pulverisation.

kg/h	Delivery pressure bar	Return pressure bar	kg/h	kW
375	20	12	147	1750
	20	18.5	295	3500
550	20	7	170	2000
	20	16	421	5000
650	20	6	180	2150
	20	17	565	6650
750	25	17	227	2700
	25	22	675	8000

Tab. G

5.11.2 Nozzle assembly

Fit the nozzle with the box spanner, fitting the spanner through the central hole in the flame stability disk (Fig. 13).

Nozzles with no fuel shutoff needle must be fitted on the nozzle holder.

To set the delivery range within which the nozzle must work, nozzle return line fuel pressure must be adjusted according to Tab. F and Tab. G.



WARNING

- Do not use any sealing products such as gaskets, sealing compound, or tape.
- Be careful to avoid damaging the nozzle sealing seat.
- The nozzles must be screwed into place tightly but not to the maximum torque value provided by the wrench.

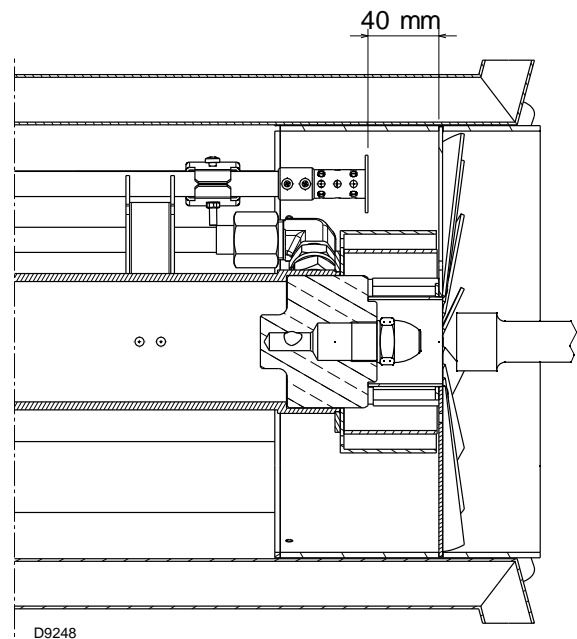

Fig. 13

5.12 Combustion head setting

In addition to varying air flow depending on the output requested, the air gate valve servomotor 4) (Fig. 4) by means of a lifting assembly - varies the setting of the combustion head.

This system allows an optimal setting even at a minimum firing rate.

For the same servomotor rotation, combustion head opening can be varied by moving the tie rod onto holes 1-2-3) (Fig. 14).

The choice of the hole (1-2-3) to be used is decided on the basis of diagram (Fig. 16) against the required maximum output.

Setting is pre-arranged in the plant for the maximum run (hole 3, Fig. 14).

If combustion requirements require you to move spacer 1) (Fig. 15) onto the 1st or 2nd hole of the gear and, at the same time, the hinge is on the right, you need to fit the spacers 4) (Fig. 15) supplied with the burner.

Proceed as follows (Fig. 15):

- unscrew nuts 2) and remove tie rod 3);
- unscrew spacer 1) and position it on the hole you want;
- screw the spacers 4) onto spacer 1) and screw 5) respectively;
- refit the tie rod and nuts.

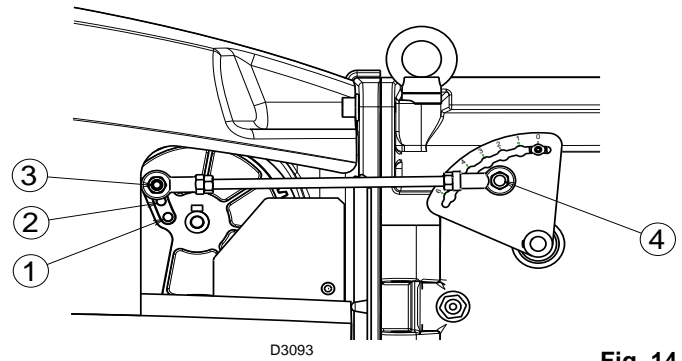

Fig. 14

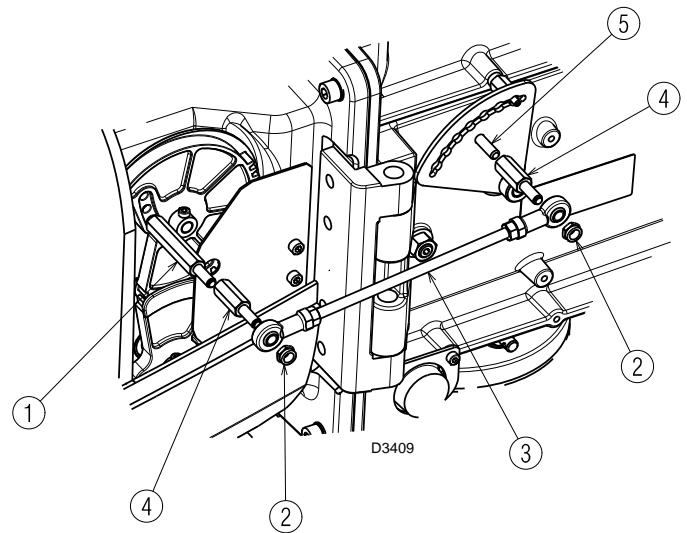

Fig. 15

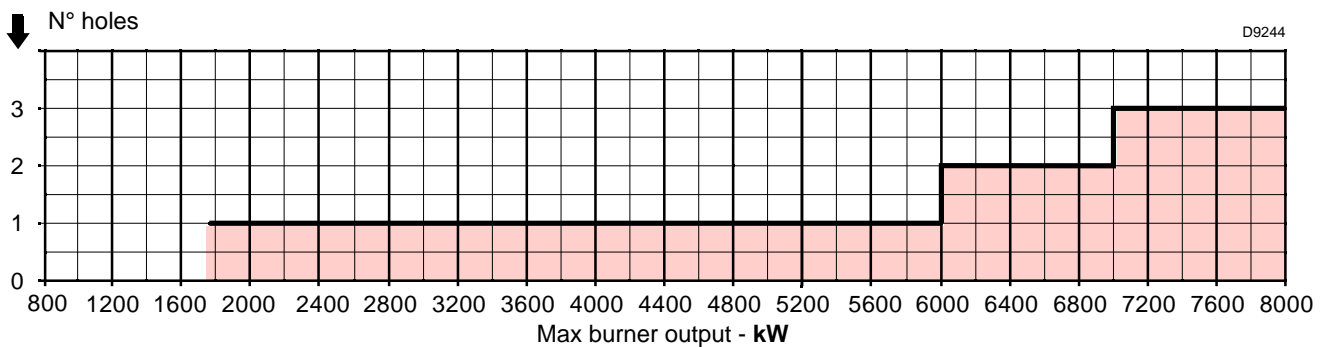

Fig. 16

5.13 Gas oil supply



Explosion danger due to fuel leaks in the presence of a flammable source.

Precautions: avoid knocking, attrition, sparks and heat.

Make sure the fuel interception tap is closed before performing any operation on the burner.



WARNING

The fuel supply line must be installed by qualified personnel, in compliance with current standards and laws.



WARNING

Where gas oil containing bio diesel is in use, it is recommended to avoid over oxygenation of the blended fuels.

Where at all possible avoid the use of two pipe systems where the circulated fuel is returned to the tank.

If this cannot be avoided make sure that the return pipe is normally below the surface of the fuel level within the storage tank.



WARNING

In case of use with gas oil containing up to 10% Bio blend, it will be essential to use flexible oil lines suitable for bio fuel use.

Please contact Riello for further information.



DANGER

It is strongly recommended a periodic check of the pump pressure operation (annually or better every six months, if the burner operation is continuous).



CAUTION

You are advised to use additional filters on the fuel supply line.

Riello recommends a good quality fuel filter at the tank (Fig. 17 - Fig. 18) and a secondary filter (100 μ for gas oil and 15 μ for kerosene) are used to protect the burner pump and nozzle from contamination.

In case of Biodiesel use, pay attention to install Biocompatible filters.

This circuit is extremely useful whenever the burner pump does not succeed in self-priming because the tank distance and/or height difference are higher than the values listed in the Tab. H.

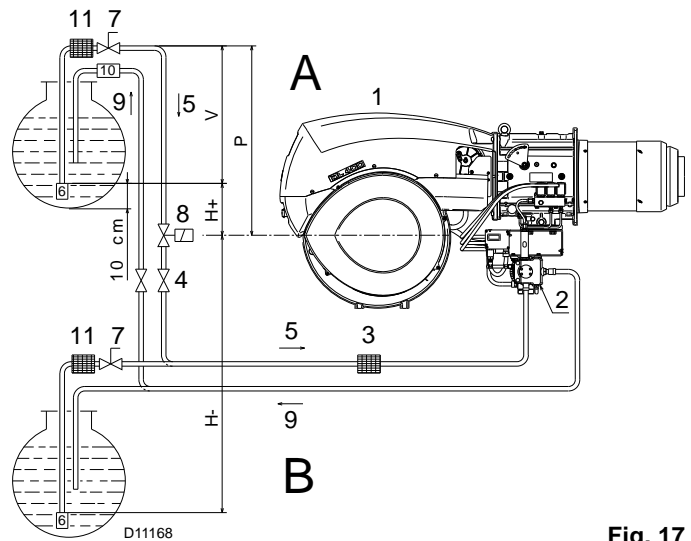

Fig. 17

- H Pump/Foot valve height difference
- L Piping length
- ∅ Inside pipe diameter
- 1 Burner
- 2 Pump
- 3 Filter
- 4 Manual on/off valve
- 5 Suction line
- 6 Foot valve
- 7 Rapid closing manual valve remote controlled (only Italy)
- 8 On/off solenoid valve (only Italy)
- 9 Return line
- 10 Check valve (only Italy)
- 11 Tank filter

5.13.1 Double-pipe circuit

The burner is equipped with a self-priming pump which is capable of feeding itself within the limits listed in the table at the side.

The tank higher than the burner A (Fig. 17)

The distance "P" must not exceed 10 meters in order to avoid subjecting the pump's seal to excessive strain; the distance "V" must not exceed 4 meters in order to permit pump self-priming even when the tank is almost completely empty.

The tank lower than the burner B (Fig. 17)

Pump depression values higher than 0.45 bar (35 cm Hg) must not be exceeded because at higher levels gas is released from the fuel, the pump starts making noise and its working life-span decreases.

It is good practice to ensure that the return and suction lines enter the burner from the same height; in this way it will be less probable that the suction line fails to prime or stops priming.

5.13.2 The loop circuit

A loop circuit consists of a loop of piping departing from and returning to the tank with an auxiliary pump that circulates the fuel under pressure.

A branch connection from the loop goes to feed the burner.

+/- H (meters)	L (meters)			
	∅ 10 (mm)	∅ 12 (mm)	∅ 14 (mm)	∅ 16 (mm)
4	14	30	55	95
3.5	13	28	52	89
3	12	26	48	82
2.5	11	24	44	76
2	10	22	41	70
1.5	9	20	37	63
1	8	18	33	57
0.5	7	16	29	51
0	6	14	26	44
-0.5	5	12	22	38
-1	4	10	18	32
-1.5	3	8	15	25
-2		6	11	19
-2.5		4	7	13
-3			4	7

Tab. H

5.13.3 Single-pipe circuit

In order to obtain single-pipe working it is necessary to unscrew the return hose, remove the by-pass screw 3)(Fig. 19) and then screw the plug 7).

The distance "P" must not exceed 10 meters in order to avoid subjecting the pump's seal to excessive strain; the distance "V" must not exceed 4 meters.

For the priming pump loosen the screw 4)(Fig. 20) in order to bleed off the air contained in the suction line and wait until the fuel flows out.

Key (Fig. 18)

- H Pump/Foot valve height difference
- L Piping length
- ∅ Inside pipe diameter
- 1 Burner
- 2 Pump
- 3 Filter
- 4 Manual on/off valve
- 5 Suction line
- 6 Foot valve
- 7 Rapid closing manual valve remote controlled (only Italy)
- 8 On/off solenoid valve (only Italy)
- 11 Tank filter

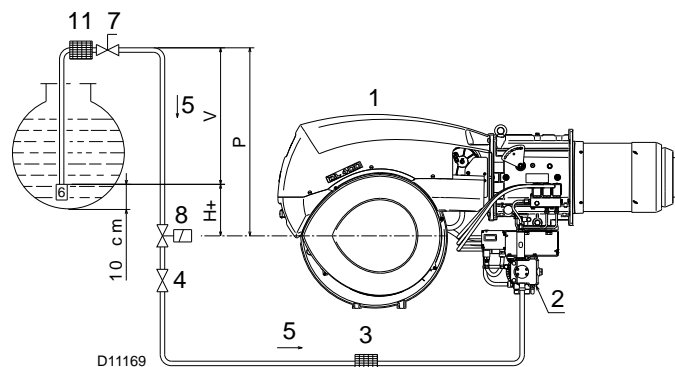

Fig. 18

+/- H (meters)	L (meters)			
	∅ 10 (mm)	∅ 12 (mm)	∅ 14 (mm)	∅ 16 (mm)
4	14	30	55	95
3.5	13	28	52	89
3	12	26	48	82
2.5	11	24	44	76
2	10	22	41	70
1.5	9	20	37	63
1	8	18	33	57
0.5	7	16	29	51

Tab. I

5.14 Hydraulic system layout

Key (Fig. 19)

- 1 Pump suction
- 2 Pump and nozzle return
- 3 By-pass screw in pump
- 4 Pump pressure governor
- 5 Safety solenoid
- 6 Safety solenoid
- 7 Nozzle delivery
- 8 Nozzle without interception pin
- 9 Nozzle return
- 10 Pressure regulator on nozzle return
- 11 Servomotor
- 12 Pressure switch on nozzle return
- 13 Safety valve on nozzle return
- 14 Safety valve on nozzle return
- 15 Pressure switch on pump delivery
- B Oil valve assembly and pressure variator
- M Pressure gauge
- V Vacuometer

OPERATION

- **Pre-purging phase:** of closed valves 5), 6), 13) and 14).
- **Firing phase and operation:** of opened valves 5), 6), 13) and 14).
- **Halt:** all the valves closed.

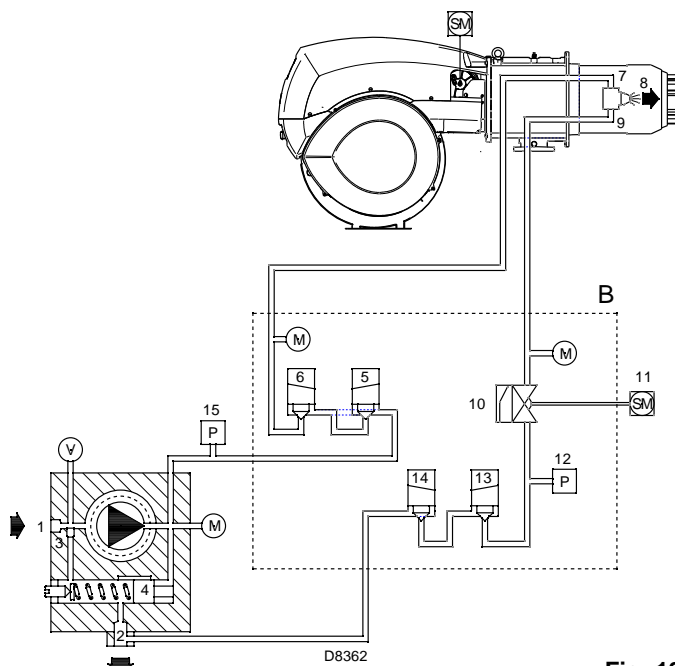

Fig. 19

5.15 Hydraulic connections

The pumps are equipped with a by-pass that connects return line with suction line.

The pumps are installed on the burner with the by-pass closed by screw 6)(Fig. 20).

It is therefore necessary to connect both hoses to the pump.

The pump will break down immediately if it is run with the return line closed and the by-pass screw inserted.

Remove the plugs from the suction and return connections of the pump.

Insert the hose connections with the supplied seals into the connections and screw them down.



WARNING

Take care that the hoses are not stretched or twisted during installation.

Install the hoses where they cannot be stepped on or come into contact with hot surfaces of the boiler and where they do not hamper the opening of the burner.

Now connect the other end of the hoses to the suction and return lines by using the supplied nipples.

5.16 Pump



WARNING

In case of use with gas oil containing up to 10% Bio blend, it will be essential to use flexible oil lines suitable for bio fuel use.

Please contact Riello for further information.

5.16.2 Pump priming



WARNING

Before starting the burner, make sure that the tank return line is not clogged.

Obstructions in the line could cause the sealing organ located on the pump shaft to break. (The pump leaves the factory with the by-pass closed).

- In order for self-priming to take place, one of the screw 4) (Fig. 20) of the pump must be loosened in order to bleed off the air contained in the suction line.
- Start the burner by closing the remote controls. Check the fan wheel rotation direction as soon as the burner starts.
- The pump can be considered primed when the gas oil starts coming out of the screw 4). Stop the burner and screw screw 4) in.

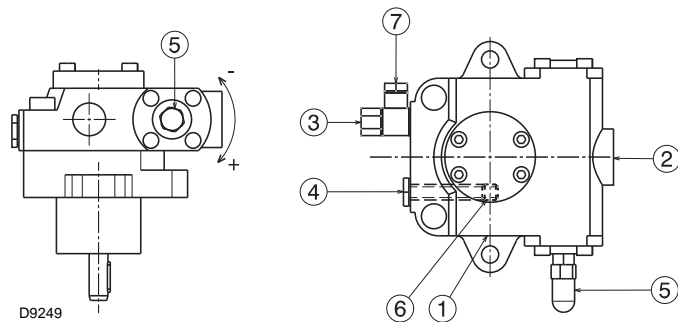

Fig. 20

Key (Fig. 20)

- 1 Suction G 1/2"
- 2 Return G 1/2"
- 3 Pressure switch attachment G 1/4"
- 4 Vacuum meter connection G 1/4"
- 5 Pressure governor
- 6 Screw for by-pass
- 7 Pressure gauge connection G 1/4"

5.16.1 Technical data

Suntec TA5

Min. delivery rate at 16.5 bar pressure	kg/h	1450
Delivery pressure range	bar	7 - 30
Max. suction depression	bar	0.45
Viscosity range	mm ² /s (cSt)	3 - 75
Max. gas oil temperature	°C	140
Max. suction and return pressure	bar	5
Pressure calibration in the factory	bar	30
Filter mesh width	mm	0.17

Tab. J

The time required for this operation depends upon the diameter and length of the suction tubing.

If the pump fails to prime at the first starting of the burner and the burner locks out, wait approx. 15 seconds, reset the burner, as often as required. After 5 or 6 starting operations allow 2 or 3 minutes for the transformer to cool.

Do not illuminate the UV photocell or the burner will lock out; the burner should lock out anyway about 10 seconds after it starts.



WARNING

The a.m. operation is possible because the pump is already full of fuel when it leaves the factory. If the pump has been drained, fill it with fuel through the opening on the vacuum meter 4)(Fig. 20) prior to starting; otherwise, the pump will seize.

Whenever the length of the suction piping exceeds 20-30 meters, the supply line must be filled using a separate pump.

5.17 Pressure regulator

Calibration pressure on return line

With a servomotor position of 20°, the nut and the corresponding lock nut 6)(Fig. 21), are fixed in contact with the eccentric 8).

During the rotation towards 130° of the servomotor, the eccentric will push the modulator shaft, taking the pressure, read on the pressure gauge 3)(Fig. 21), to the desired value.

To calibrate the eccentric, proceed as follow:

- loosen the screws 7), and act on the screw 4) to obtain the desired eccentricity.
- Turn clockwise (+) the screw 4) to increase the eccentricity, increasing the difference between the min. and max. capacity of the nozzle.
- Turn anticlockwise (-) to decrease the eccentricity and, consequently the difference between the min. and max. capacity of the nozzle.

Calibration pressure on delivery line

To adjust the delivery pressure, operate on the pump as described on page 22.

Example:

if you use a 650 kg/h nozzle and you want to obtain power of 6650 kW, the pressure on the pressure gauge 3)(Fig. 21) (maximum pressure on return circuit) must be about 16.5 bar.

Relevant delivery pressure read on the pressure gauge 2), must be 20 bar (see Table F on page 18).

IMPORTANT

- The proper setting of the eccentric 8) is possible when its operation field follows the servomotor operation field (20° - 130°): so, that every variation of the servomotor position corresponds to a pressure variation.
- Never let the piston batter: the stop ring 5) determines the max. stroke.
- If you wish to check the delivery capacity of the nozzle, proceed as follows:
open the burner according to instructions at page 17, place the nozzle, simulate the start-up and then proceed with the weighing at the maximum and minimum pressures.
- If at maximum capacity of the nozzle (maximum pressure in the return line) pressure fluctuations are detected on the manometer 3), slightly decrease the pressure till their complete elimination.

NOTE:

the burner is calibrated from factory with maximum pressure on the return line of approximately 16.5 bar and delivery pressure of approximately 20 bar.

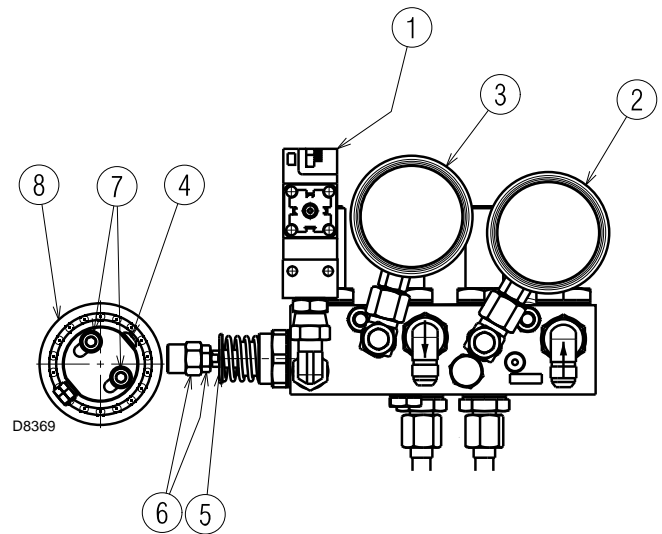

Fig. 21

Key (Fig. 21)

- 1 Maximum oil pressure switch
- 2 Manometer for pressure in delivery line
- 3 Manometer for pressure in return line
- 4 Eccentric adjusting screw
- 5 Ring for piston stop
- 6 Nut and lock-nut for piston setting
- 7 Eccentric locking screws
- 8 Variable eccentric

5.18 Gas feeding



Explosion danger due to fuel leaks in the presence of a flammable source.

Precautions: avoid knocking, attrition, sparks and heat.

Make sure the fuel interception tap is closed before performing any operation on the burner.



The fuel supply line must be installed by qualified personnel, in compliance with current standards and laws.

5.18.1 Gas feeding line

Key (Fig. 22 - Fig. 23 - Fig. 24 - Fig. 25)

- 1 Gas input pipe
- 2 Manual valve
- 3 Vibration damping joint
- 4 Pressure gauge with pushbutton cock
- 5 Filter
- 6A Includes:
 - filter
 - working valve
 - safety valve
 - pressure adjuster
- 6B Includes
 - working valve
 - safety valve
 - pressure adjuster
- 6C Includes
 - safety valve
 - working valve
- 6D Includes:
 - safety valve
 - working valve
- 7 Minimum gas pressure switch
- 8 Leak detection control, provided as an accessory or integrated, based on the gas train code. In compliance with the EN 676 standard, the leak detection control is compulsory for burners with maximum outputs over 1200 kW.
- 9 Gasket, for "flanged" versions only
- 10 Pressure adjuster
- 11 Train-Burner adaptor, supplied separately
- P2 Upline pressure of valves/adjuster
- P3 Upstream pressure of the filter
- L Gas train, supplied separately
- L1 The responsibility of the installer

MBC "threaded"

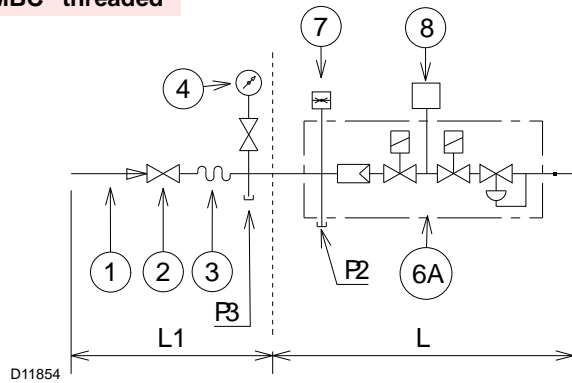

Fig. 22

MBC "flanged"

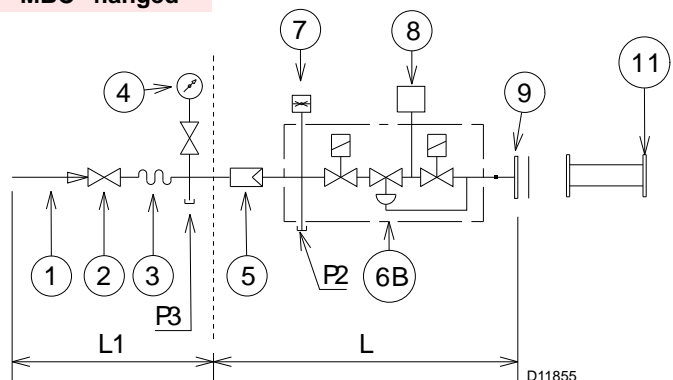

Fig. 23

DMV "flanged or threaded"

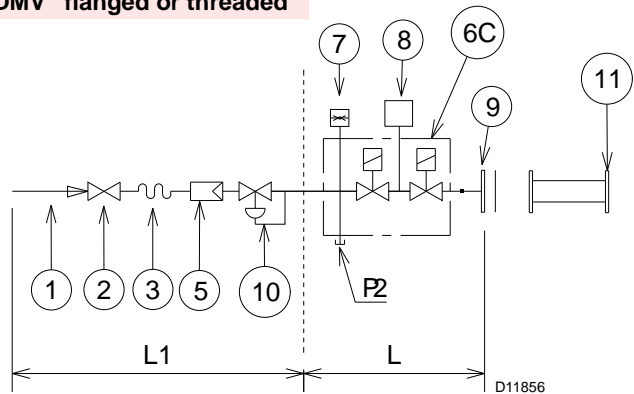

Fig. 24

CB "flanged or threaded"

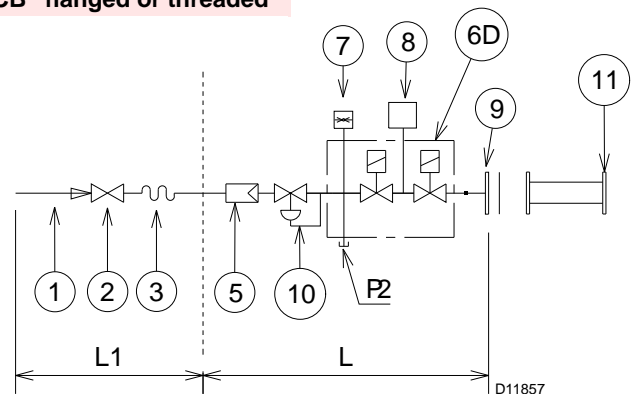

Fig. 25

5.18.2 Gas train

Approved according to standard EN 676 and provided separately from the burner.

To select the correct gas train model, refer to the supplied "Burner-gas train combination" manual.

5.18.3 Gas train installation



Disconnect the electrical power using the main switch.



Check that there are no gas leaks.



Pay attention when handling the train: danger of crushing of limbs.



Make sure that the gas train is properly installed by checking for any fuel leaks.



The operator must use the required equipment during installation.

The gas train is to be connected on the right of the burner, by flange 1) (Fig. 26).

If it is necessary to connect it on the left of the burner, loosen nuts and screws 3) and 4), remove blind flange 2) together with its gasket and fit them to flange 1) tightening the nuts and screws.

Note

Once assembled the gas train, check for leaks.

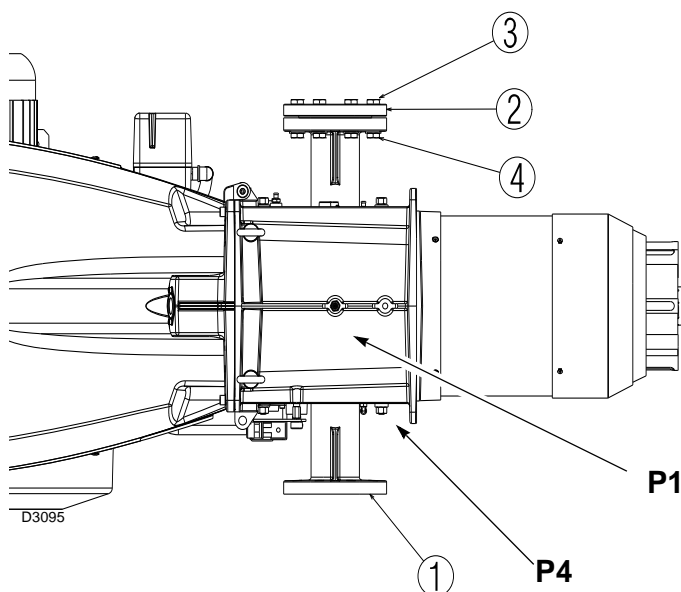

Fig. 26

5.18.4 Gas pressure

Tab. K indicates the pressure drop of the combustion head and the gas butterfly valve depending on the operating output of the burner.

kW	1 Δp (mbar)		2 Δp (mbar)	
	G 20	G 25	G 20	G 25
3500	11,5	16,5	2,7	3,5
4000	15,2	22,3	3,6	4,6
4500	19,0	28,1	4,5	5,8
5000	22,7	33,9	5,5	7,2
5500	26,4	39,7	6,7	8,7
6000	30,2	45,5	8,0	10,3
6500	35,4	51,3	9,4	12,1
7000	38,9	57,9	10,9	14,0
7500	44,8	66,6	12,5	16,1
8000	50,6	75,4	14,2	18,3

Tab. K

The values shown in Tab. K refer to:

- Natural gas G 20 NCV 9.45 kWh/Sm³ (8.2 Mcal/Sm³)
- Natural gas G 25 NCV 8.13 kWh/Sm³ (7.0 Mcal/Sm³)

Column 1

Combustion head pressure drop.

Gas pressure measured at test point P1)(Fig. 27), with:

- combustion chamber at 0 mbar;
- burner working at maximum modulating output;
- combustion head set as on page 19.

Column 2

Pressure loss at gas butterfly valve P2)(Fig. 27) with maximum opening: 90°.

To calculate the approximate output at which the burner operates:

- subtract the combustion chamber pressure from the gas pressure measured at test point P1)(Fig. 27).
- Find, in Tab. K related to the burner concerned, the pressure value closest to the result of the subtraction.
- Read off the corresponding output on the left.

Example with natural gas G20:

Operation at maximum modulating output

$$\begin{aligned} \text{Gas pressure at test point P1)(Fig. 27)} &= 35.2 \text{ mbar} \\ \text{Pressure in combustion chamber} &= 5 \text{ mbar} \\ 35.2 - 5 &= 30.2 \text{ mbar} \end{aligned}$$

A pressure of 30.2 mbar, column 1, corresponds in Tab. K to an output of 6000 kW.

This value serves as a rough guide; the effective output must be measured at the gas meter.

To calculate the required gas pressure at test point P1)(Fig. 27), set the maximum modulating output required from the burner operation:

- find the nearest output value in Tab. K for the burner in question.
- Read, on the right (column 1), the pressure at the test point P1) (Fig. 27).
- Add this value to the estimated pressure in the combustion chamber.

Example with natural gas G20:

Operation at maximum modulating output
 Gas pressure at an output of 6000 kW = 30.2 mbar
 Pressure in combustion chamber = 5 mbar
 30.2 + 5 = 35.2 mbar
 pressure required at test point P1)(Fig. 27).

5.18.5 Pilot - gas train connection

The burner is fitted with a dedicated gas train that is fixed to the pipe coupling.

➤ It should be connected to the main train downstream the filter or the pressure adjuster (depending on configuration).

Oil burners (with LPG pilot) can be directly connected to the LPG cylinder.



Supply pressure 68 ÷ 500 mbar.

5.18.6 Ignition pilot burner

For proper operation, adjust gas pressure (measured at pressure test point 1)(Fig. 28) as follows: 16 mbar (7.3 Nm³/h).



Check pilot flame stability before starting up the main burner.

In the case of ignition problems check:

- correct positioning of the ignition electrode;
- the gas pressure, according to indications.

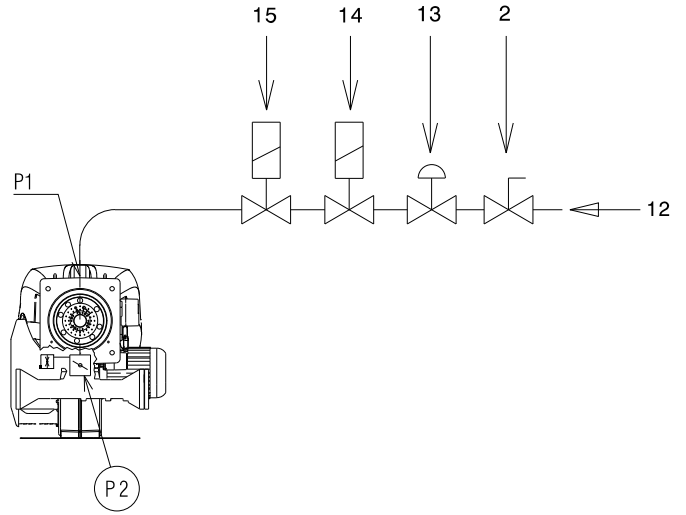

20070790

Fig. 27

Key (Fig. 27)

- P1 Pressure test point at the combustion head
- P2 Pressure test point at the gas butterfly valve
- 2 Manual on/off valve
- 12 Pilot gas supply
- 13 Pressure adjuster of pilot line
- 14 Safety valve
- 15 Operation valve

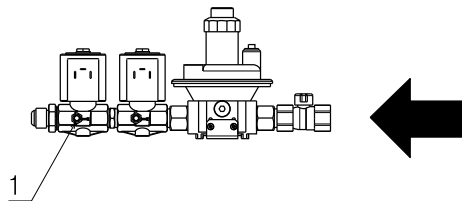
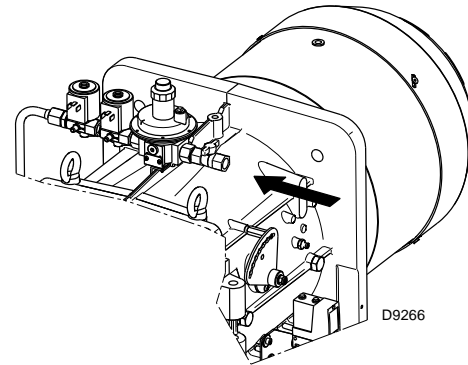

Fig. 28

5.19 Electrical wiring

Notes on safety for the electrical wiring



- The electrical wiring must be carried out with the electrical supply disconnected.
- Electrical wiring must be made in accordance with the regulations currently in force in the country of destination and by qualified personnel. Refer to the wiring diagrams.
- The manufacturer declines all responsibility for modifications or connections different from those shown in the wiring diagrams.
- Check that the electrical supply of the burner corresponds to that shown on the identification label and in this manual.
- The burner has been type-approved for intermittent use.
This means they should compulsorily be stopped at least once every 24 hours to enable the control box to perform checks of its own start-up efficiency. Normally, burner stopping is guaranteed by the boiler's thermostat/pressure switch.
- If this is not the case, a time switch should be fitted in series to TL to stop the burner at least once every 24 hours. Refer to the wiring diagrams.
- The electrical safety of the device is obtained only when it is correctly connected to an efficient earthing system, made according to current standards. It is necessary to check this fundamental safety requirement. In the event of doubt, have the electrical system checked by qualified personnel. Do not use the gas tubes as an earthing system for electrical devices.
- The electrical system must be suitable for the maximum power absorption of the device, as indicated on the label and in the manual, checking in particular that the section of the cables is suitable for that level of power absorption.
- For the main power supply of the device from the electricity mains:
 - do not use adapters, multiple sockets or extensions;
 - use a multiple pole switch with at least a 3mm gap between the contacts (overvoltage category III), as envisaged by the present safety standards.
- Do not touch the device with wet or damp body parts and/or in bare feet.
- Do not pull the electric cables.

Before carrying out any maintenance, cleaning or checking operations:



Disconnect the electrical supply from the burner by means of the main system switch.



Turn off the fuel interception tap.



Avoid condensate, ice and water leaks from forming.

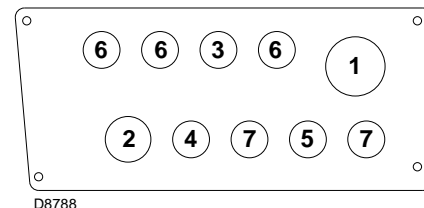
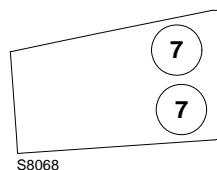

Fig. 29



After carrying out maintenance, cleaning or checking operations, reassemble the hood and all the safety and protection devices of the burner.

If the cover is still present, remove it and proceed with the electrical wiring according to the wiring diagrams.

Use flexible cables in compliance with the EN 60 335-1 standard.

5.19.1 Supply cables and external connections passage

All the cables to be connected to the burner are fed through the grommets, as shown in Fig. 29.

Key to layout (Fig. 29)

- 1 Electrical supply
- 2 Fan motor
- 3 Minimum gas pressure switch
- 4 Pressure switch for gas leak detection control device VPS
- 5 Gas train
- 6 Triggering / Safety devices
- 7 Available

5.20 Calibration of the thermal relay

The thermal relay (Fig. 30) is used to avoid damage to the motor owing to a strong increase in absorption or the lack of a phase.

For the calibration 2), refer to the table given in electrical layout (Electrical connections set by installer).

To reset, in the case of an intervention of the thermal relay, press the button "RESET" 1).

The button "STOP" 3) opens the NC (95-96) contact and stops the motor.

To test the thermal relay, insert a screwdriver in the window "TEST/TRIP" 4) and move it in the sense of the arrow (towards right)



**Automatic resetting can be dangerous.
This action is not provided for the burner operation.**

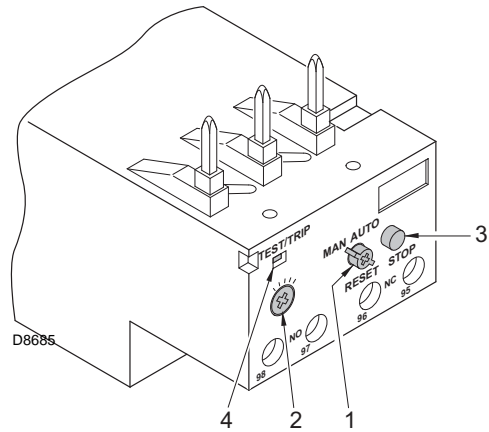

Fig. 30

6 Start-up, calibration and operation of the burner

6.1 Notes on safety for the first start-up



The first start-up of the burner must be carried out by qualified personnel, as indicated in this manual and in compliance with the standards and regulations of the laws in force.



Check the correct working of the adjustment, command and safety devices.

6.2 Adjustment before first firing (gas oil operation)

It is advisable to first set the burner for operating on oil and then for gas.



Execute the fuel exchange when the burner is off.

The optimum calibration of the burner requires an analysis of the flue gases at the boiler outlet and interventions on the following points. Adjust successively:

Nozzles

See the information listed on page 18.

Combustion head

The adjustment of the combustion head already carried out (page 19) need not be altered unless the 2nd stage delivery of the burner is changed.

Pump pressure

25 bar: In order to adjust pump pressure, use the relevant screw 5)(Fig. 20).

Fan air gate valve

See servomotor adjustment page 30.

6.3 Burner firing

Set the switch 1)(Fig. 31) to "MAN" position. During the first firing, the burner must generate a noise similar to the noise generated during operation.

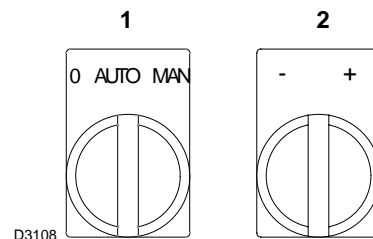

Fig. 31

6.4 Fuel change

- There are two possible options for changing fuel:
- 1 using selector 3)(Fig. 32);
 - 2 using a remote selector connected to the main terminal board.

By setting selector 3)(Fig. 32) to "EXT", you activate the remote fuel selection facility.

In this position, if no remote selector is fitted, the display shows the priority fuel.

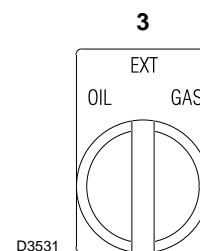

Fig. 32

6.5 Adjustments before first firing (gas operation)

Adjustment of the combustion head has been illustrated on page 19.

In addition, the following adjustments must also be made:

- Slowly open the manual valves situated upstream of the gas train.
- Adjust the minimum gas pressure switch to the start of the scale.
- Adjust the maximum gas pressure switch to the start of the scale.
- Adjust the air pressure switch to the zero position of the scale.
- Purge the air from the gas line. Continue to purge the air (we recommend using a plastic tube routed outside the building) until gas is smelt.
- Fit a U-type manometer or a differential pressure gauge (Fig. 33), with the (+) fitting on the header gas pressure tap and (-) fitting in the combustion chamber. The manometer readings are used to calculate MAX. burner power using the Tab. K on page 25.
- Connect two lamps or testers to the two gas line solenoid valves to check the exact moment at which voltage is supplied. This operation is unnecessary if each of the two solenoid valves is equipped with a pilot light that signals voltage passing through.



Before starting up the burner it is good practice to adjust the gas train so that ignition takes place in conditions of maximum safety, i.e. with gas delivery at the minimum.

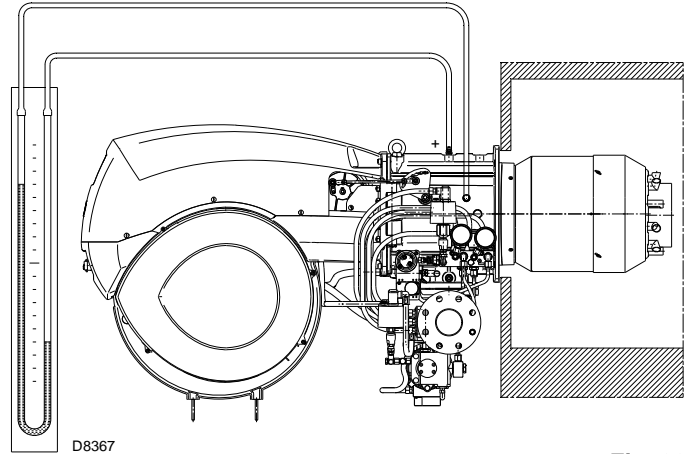

Fig. 33

6.6 Burner starting

Close load controls and set the switch 1)(Fig. 31) to "MAN" position.

Make sure that the lamps or testers connected to the solenoids, or pilot lights on the solenoids themselves, indicate that no voltage is present.

If voltage is present, then immediately stop the burner and check electrical connections.

6.7 Burner firing

Having completed the checks indicated in the previous heading, the burner should fire.

If the motor starts but the flame does not appear and the control box goes into lock-out, reset and wait for a new firing attempt.

If firing is still not achieved, it may be that gas is not reaching the combustion head within the safety time period of 3 seconds.

In this case increase gas firing delivery. The arrival of gas at the sleeve is indicated by the U-type manometer (Fig. 33). After burner firing a complete burner adjustment should be performed.

6.8 Servomotor

The servomotor (Fig. 34) simultaneously regulates, through a transmission system, air delivery and pressure and delivery of the fuel in use.

It is fitted with adjustable cams which drive a similar number of selector switches.

- Cam 1:** Sets the servomotor limit switch to max. position (130° ca.) (Oil operation).
- Cam 2:** Sets the servomotor limit switch to 0° position. When the burner is off, the air damper is completely closed (Oil and gas operation).
- Cam 3:** Regulates minimum modulation delivery. It is factory calibrated in the 45°. (Oil operation at minimum).
- Cam 4:** Sets the servomotor limit switch to max. position (130° ca.) (Gas operation).
- Cam 5:** Regulates minimum modulation delivery. It is factory calibrated in the 45°. (Gas operation).
- Rem. cam:** No utilized.
- Lever 7:** Servomotor release.

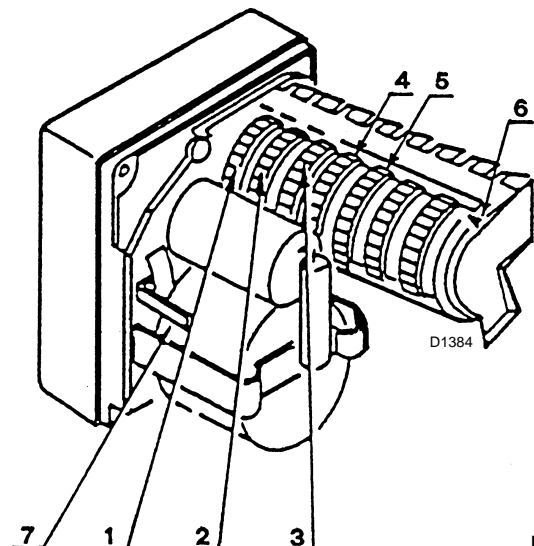

Fig. 34

6.9 Fuel/combustion air adjustment

Fuel/combustion air is synchronised by means of a servomotor connected to two variable-profile cams which operate the air delivery 1)(Fig. 35) and fuel delivery 2) dampers and, by means of suitable leverages, the combustion head.

To reduce pressure loss and to have a wider adjustment range, it is best to set the servomotor to the maximum output used, as near to maximum opening (130°) as possible.

On the gas butterfly valve, the fuel's partial setting adjustment based on required output, with the servomotor fully open, is made by using the pressure stabilizer on the train.

The value reported in the Tab. L and Tab. M can be a reference for a good combustion setting.

EN 267	Excess air		
	Max output $\lambda \leq 1.2$		Min output $\lambda \leq 1.3$
Theoretical max. CO ₂ 0 % O ₂	Calibration CO ₂ %		CO mg/kWh
	$\lambda = 1.2$	$\lambda = 1.3$	
15.2	12.6	11.5	≤ 100

Tab. L

EN 676	Excess air			
	Max output $\lambda \leq 1.2$		Min output $\lambda \leq 1.3$	
GAS	Theoretical max. CO ₂ 0 % O ₂	Calibration CO ₂ %		CO mg/kWh
		$\lambda = 1.2$	$\lambda = 1.3$	
G 20	11.7	9.7	9.0	≤ 100
G 25	11.5	9.5	8.8	≤ 100
G 30	14.0	11.6	10.7	≤ 100
G 31	13.7	11.4	10.5	≤ 100

Tab. M

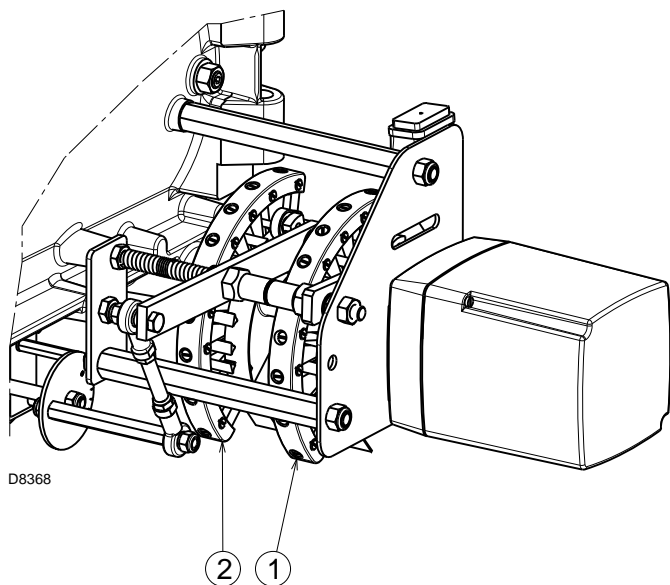

Fig. 35

6.9.1 Maximum output

Set the servomotor to maximum opening so that the air dampers are fully open.

6.9.2 Minimum output

Max output of the burner must be set within the firing rate range shown on page 11.

Turn the "decrease output" selector 2)(Fig. 31) and keep it turned towards "-" until the servomotor has closed the air damper and the gas butterfly valve is at 35° (factory setting).

Adjustment of air delivery

Progressively adjust the starting profile of cam 1)(Fig. 36) by turning the screws 2)(Fig. 36).

It is preferable not to turn the first screw since this is used to set the air gate valve to its fully-closed position.

6.9.3 Intermediate outputs

Once you have adjusted the burner's maximum and minimum output, the next step is to adjust air and gas at the various intermediate servomotor positions.

You can switch from one position to the next by holding selector 2)(Fig. 31) on the (+) or (-) symbol.

For improved adjustment repeatability, make sure you stop rotation of the cam assembly when the upper bearing running on the profile 4)(Fig. 36) is aligned with one of the adjusting screws 2) (Fig. 36).

Tighten or loosen the preselected screw 2)(Fig. 36) to increase or decrease airflow so as to adapt it to the corresponding gas flow.

Once output adjustments (maximum, medium and intermediate) have been carried out, it is important you secure all the air regulation screws 2)(Fig. 36) with the locking screws 3)(Fig. 36) so as to prevent possible shifting of air-gas setting positions.

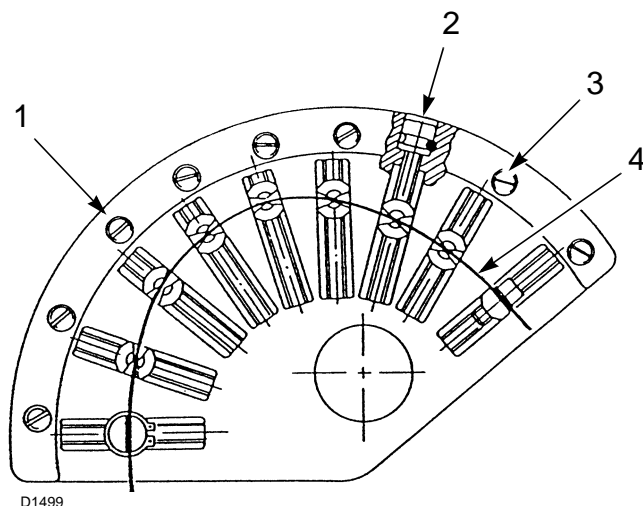

Fig. 36

Key (Fig. 36)

- 1 Cam
- 2 Adjustment screws
- 3 Fixing screws
- 4 Variable profile

6.10 Air/fuel ratio adjustment

When setting the air/fuel ratio for oil burners, the following adjustments must be made:

- A Delivery pressure of the oil pump:**
turn the screw 5)(Fig. 20), on the pump.
- B Air cam:**
turn the threaded regulators 2)(Fig. 36) after loosening the screws 3)(Fig. 36).
- C Gas cam:**
adjust set screws 2)(Fig. 36) after loosening the screws 3) (Fig. 36).
- D Oil cam:**
change eccentricity by turning the screw 4)(Fig. 37) after loosening the screws 7)(Fig. 37).
By tightening the screw 4)(Fig. 37) eccentricity increases, in this way the difference increases between maximum and minimum return pressure to the nozzle.

6.10.1 Procedures for setting the burner

- Fit the suitable nozzle to obtain the maximum required delivery.
- Check that the eccentricity of the oil cam is sufficient for a run of approx. 8 mm for the oil modulator shaft.
Normally, with an 8 mm run for the shaft, the pressure variation required for modulating the output from minimum to maximum is obtained.
To carry out this control, manually turn the cam after releasing the servomotor using the lever 7)(Fig. 34), so that the shaft run is not excessive or insufficient. When the control is terminated, remember to block the servomotor.
- Ignite the burner with the selector switch on the control panel in the manual position 1)(Fig. 31).
At this point, after the pre-ventilation phase, the servomotor will stop at approx. 20°.
- Adjust the pump delivery pressure as given in point **A (delivery pressure of the oil pump)**, to obtain a delivery pressure of 24 - 25 bar.
- Adjust the return pressure to a minimum of approx. 6 bar.
To do this, the length of the shaft 5)(Fig. 37) must be adjusted, by turning the nut 6)(Fig. 37).
- Proceed with setting the air delivery by adjusting the variable profile cam, by turning the screws 2)(Fig. 36).
- After this first adjustment, increase supply output using the automatic return selection switch on the control panel. Stop when the servomotor has turned by 15° and then effect a new adjustment using the variable profile air cam.
We recommend sufficient setting so as not to create a smoky flame and to reach maximum output as soon as possible (maximum run for the servomotor 130°): set the return pressure on the eccentric (screw 4, Fig. 37) to obtain the output required by the nozzle and then continue with setting the intermediate levels.
- Check the levels of the combustion parameters at the various modulation outputs and adjust if necessary.
- Move selector 3)(Fig. 32) to **GAS** and check the correct operation on gas at the desired power.
If operation was not correct, calibrate gas cam according to the above mentioned point **C (Gas cam)**.
- When perfect adjustment has been reached, remember to block the adjustment screws of the cam profiles by tightening the screws 3)(Fig. 36).



When setting the cams, do not exceed the servomotor run limits 0° ÷ 130°, to avoid crawling. Check, by effecting a manual movement of the cam of 0-130°, that there are no mechanical blocks before the micro-switches 1-2 on the servomotor trigger.

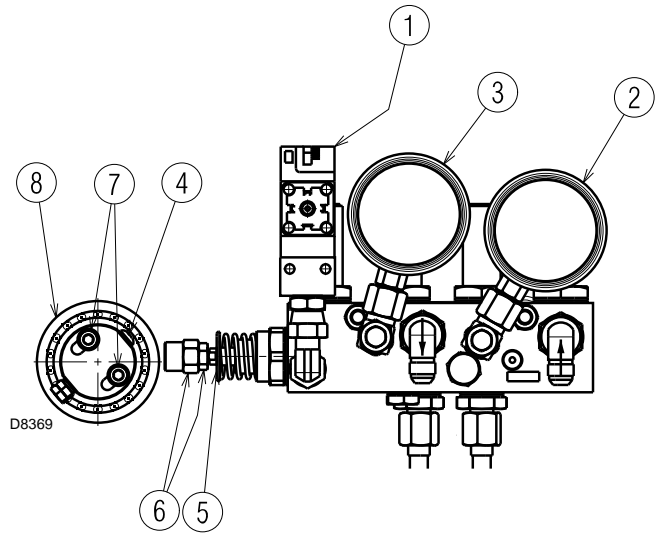

Fig. 37

Key (Fig. 37)

- 1 Maximum oil pressure switch
- 2 Manometer for pressure in delivery line
- 3 Manometer for pressure in return line
- 4 Eccentric adjusting screw
- 5 Ring for piston stop
- 6 Nut and lock-nut for piston setting
- 7 Eccentric locking screws
- 8 Variable eccentric

6.11 Adjustment pressure switches

6.11.1 Air pressure switch - CO check

Adjust the air pressure switch after having performed all other burner adjustments with the air pressure switch set to the start of the scale (Fig. 38).

With the burner operating at minimum output, increase adjustment pressure by slowly turning the relative knob clockwise until the burner locks out.

Then turn the knob anti-clockwise by about 20% of the set point and repeat burner starting to ensure it is correct.

If the burner locks out again, turn the knob anti-clockwise a little bit more.



As a rule, the air pressure switch must prevent the air pressure from lowering below 80% of the adjustment value as well as preventing the CO in the fumes from exceeding 1% (10,000 ppm).

To check this, insert a combustion analyser into the chimney, slowly close the fan suction inlet (for example with cardboard) and check that the burner locks out, before the CO in the fumes exceeds 1%.

The air pressure switch is fitted in an “absolute” mode, that is, connected only to the pressure test point “+” 22)(Fig. 4).



Fig. 38

6.11.2 Max. gas pressure switch

Adjust the maximum gas pressure switch after having performed all the other burner adjustments with the pressure switch set at the end of the scale (Fig. 39).

With the burner operating at maximum output, decrease adjustment pressure by slowly turning the relative knob anti-clockwise until the burner locks out.

Then turn the knob clockwise by 0,2 kPa (2 mbar) and repeat burner starting to ensure it is uniform.

If the burner locks out again, turn the knob anti-clockwise again by 0,1 kPa (1 mbar).

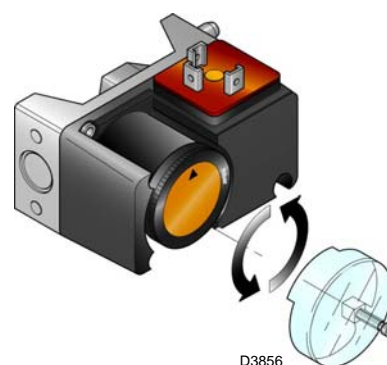

Fig. 39

6.11.3 Min. gas pressure switch

Adjust the minimum gas pressure switch after having performed all the other burner adjustments with the pressure switch set at the start of the scale (Fig. 40).

With the burner operating at maximum output, increase adjustment pressure by slowly turning the relative knob clockwise until the burner locks out.

Then turn the knob anti-clockwise by 0,2 kPa (2 mbar) and repeat burner starting to ensure it is uniform.

If the burner locks out again, turn the knob anti-clockwise again by 0,1 kPa (1 mbar).

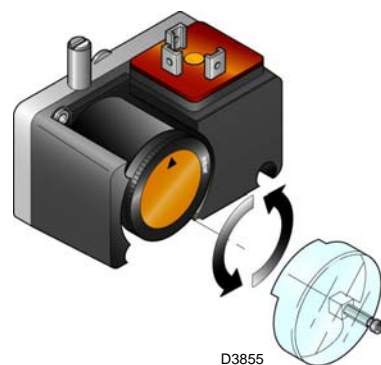

Fig. 40



1 kPa = 10 mbar

6.12 Operation sequence of the burner

6.12.1 Burner starting

- 0s Thermostat/pressure switch TL closes. Fan motor starts.
- 6s Motor starts. Servomotor starts: 130° rotation to right, until contact is made on cam 1) with gas oil operation, or cam 4) with gas operation.
- 48s The air gate valve is positioned on MAX. output. Pre-purge stage with air delivery at MAX. output.
- 80s Servomotor rotates to left up to the angle set on cam 3) with gas oil operation, or cam 5) with gas operation.
- 109s The air gate valve and the gas butterfly are positioned to MIN. output.
- 113 s Ignition electrode strikes a spark.
- 116s Pilot valve VP1 and VP2 open. The flame is ignited at a low output level point A (Fig. 41).
- 119 s The spark goes out.
- 130s Safety valve VS and adjustment valve VR (rapid stroke) open. Delivery is then progressively increased, with the valve opening slowly up to MIN output, point B (Fig. 41).
- 143s The control box starting cycle ends.

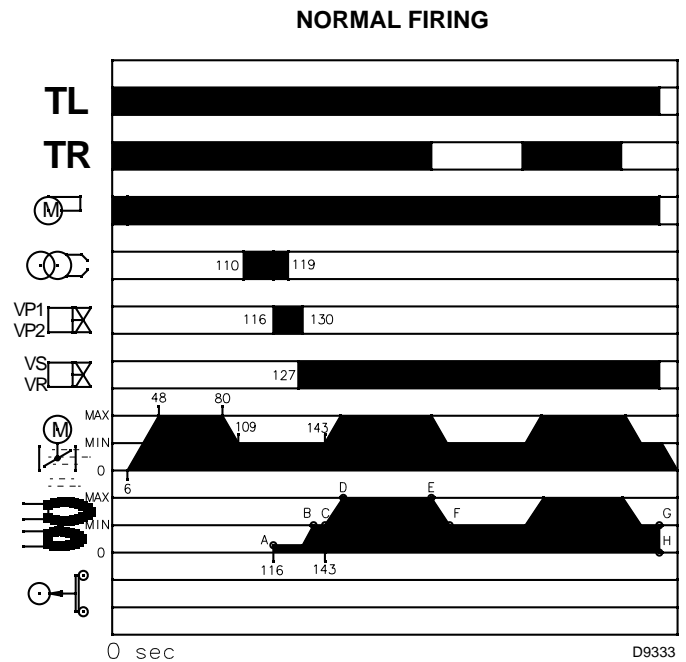

Fig. 41

6.12.2 Steady state operation

► Burner without output regulator RWF

At the end of the starting cycle, the servomotor control then passes to the thermostat/pressure switch TR for boiler pressure or temperature point C (Fig. 41).

(The control box continues, however, to check that the flame is present and that the air and gas max. pressure switches are in the correct position).

- If the temperature or pressure is low (and the thermostat/pressure switch TR is consequently closed), the burner progressively increases its output to the MAX. value, (section C-D).
- If subsequently the temperature or pressure increases until thermostat/pressure switch TR opens, the burner progressively decreases its output to the MIN. value (section E-F). And so on.
- The burner locks out when demand for heat is less than the heat supplied by the burner at min. output (section G-H). Thermostat/pressure switch TL opens. The servomotor returns to the 0° angle limited by contact with cam 2). The gate valve closes completely to reduce thermal dispersion to a minimum.

Every time output is changed, the servomotor automatically modifies gas delivery (gas butterfly valve), air delivery (fan gate valve) and air pressure (2 shutters in the combustion head).

► Burner with output regulator RWF

See the handbook enclosed with the regulator.

6.12.3 Undesired shutdown during operation

If the flame should accidentally go out during operation, the burner will lock out within 1s.

6.12.4 Firing failure

If the burner does not fire, it goes into lock-out within (Fig. 42) 3 s of the opening of the gas solenoid valve and 119 s after the closing of control device TL.

NO FIRING

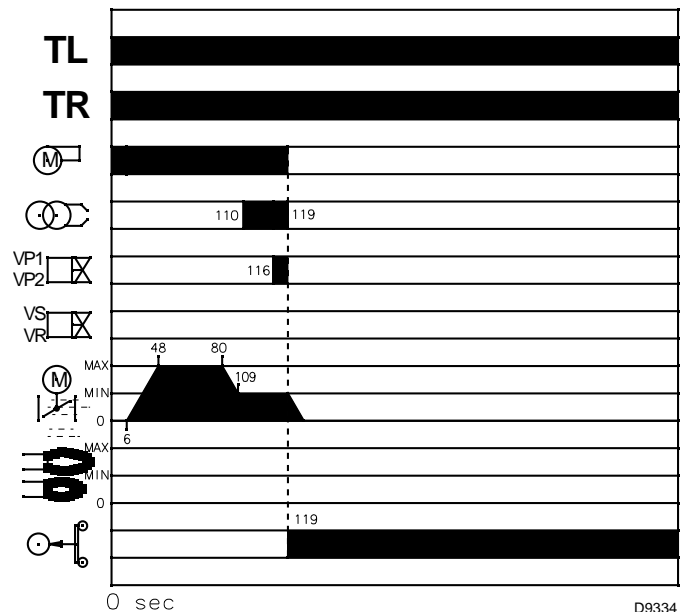





Fig. 42

6.13 Final checks (with burner operating)

<ul style="list-style-type: none"> ➤ Open the thermostat/pressure switch TL ➤ Open the thermostat/pressure switch TS 		The burner must stop
<ul style="list-style-type: none"> ➤ Turn the gas maximum pressure switch knob to the minimum end of scale position ➤ Turn the air pressure switch to the maximum end of scale position 		The burner must stop in lockout
<ul style="list-style-type: none"> ➤ Turn off the burner and cut off the power ➤ Disconnect the minimum gas pressure switch connector 		The burner must not start
<ul style="list-style-type: none"> ➤ Disconnect the UV probe wire 		The burner must stop in lockout due to ignition failure

Tab. N



WARNING

Make sure that the mechanical locking systems on the various adjustment devices are fully tightened.

7 Maintenance

7.1 Notes on safety for the maintenance

The periodic maintenance is essential for the good operation, safety, yield and duration of the burner.

It allows you to reduce consumption and polluting emissions and to keep the product in a reliable state over time.



The maintenance interventions and the calibration of the burner must only be carried out by qualified, authorised personnel, in accordance with the contents of this manual and in compliance with the standards and regulations of current laws.

Before carrying out any maintenance, cleaning or checking operations:



Disconnect the electrical supply from the burner by means of the main system switch.



Turn off the fuel interception tap.



Wait for the components in contact with heat sources to cool down completely.

7.2 Maintenance programme

7.2.1 Maintenance frequency



The gas combustion system should be checked at least once a year by a representative of the manufacturer or another specialised technician.

7.2.2 Checking and cleaning



The operator must use the required equipment during maintenance.

Combustion

The optimum calibration of the burner requires an analysis of the flue gases.

Significant differences with respect to the previous measurements indicate the points where more care should be exercised during maintenance.

Combustion head

Open the burner and make sure that all components of the combustion head are in good condition, not deformed by the high temperatures, free of impurities from the surroundings and correctly positioned.

Current to the UV photocell

Clean the glass cover from any dust that may have accumulated. Photocell is held in position by a pressure fit and can therefore be removed by pulling it outward forcefully (Fig. 43).

Min value for a good work: 70 µA.

If the value is lower, it can depend on:

- exhausted photocell
- low current (lower than 187 V)
- bad regulation of the burner.

In order to measure the current, use a microammeter of 100 µA c.c., connected to the photocell, as in the scheme, with a capacitor of 100 µF - 1V c.c. at the same level of the instrument.

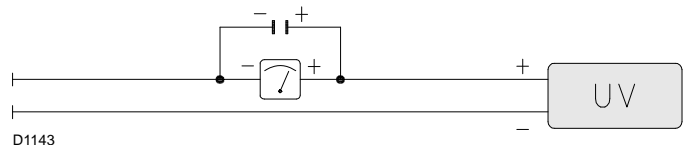

Fig. 43

Burner

Check for excess wear or loose screws, especially on cams. Clean the outside of the burner. Clean and grease the cam variable profile.

Fan

Check to make sure that no dust has accumulated inside the fan or on its blades, as this condition will cause a reduction in the air flow rate and provoke polluting combustion.

Boiler

Clean the boiler as indicated in its accompanying instructions in order to maintain all the original combustion characteristics intact, especially the flue gas temperature and combustion chamber pressure.

GAS OIL OPERATION

Filters

Check the filtering baskets on line and at nozzle present in the system. Clean or replace if necessary. If rust or other impurities are observed inside the pump, use a separate pump to lift any water and other impurities that may have deposited on the bottom of the tank.

Pump

The delivery pressure must be stable. The depression must be less than 0.4 bar. Unusual noise must not be evident during pump operation.

If the pressure is found to be unstable or if the pump runs noisily, the flexible hose must be detached from the line filter and the fuel must be sucked from a tank located near the burner. This measure permits the cause of the anomaly to be traced to either the suction piping or the pump.

If the pump is found to be responsible, check to make sure that the filter is not dirty. The vacuumeter is installed upstream from the filter and consequently will not indicate whether the filter is clogged or not. Contrarily, if the problem lies in the suction line, check to make sure that the filter is clean and that air is not entering the piping.

Please check that the supply line and filters are clear. The use of a pump vacuum gauge will assist in this. This measure permits the cause of the anomaly to be traced to either the suction line or the pump.

If the problem lies in the suction line, check to make sure that the filter is clean and that air is not entering the piping.

Hoses

- Check periodically the flexible pipes conditions. They have to be replaced at least **every 2 years**.
- In case of use of gas oil and bio fuel blends, it is strongly recommended to inspect **even more frequently** the hoses and replace them where contamination has occurred.
- Check to make sure that the hoses are still in good condition.

Nozzles

Do not clean the nozzle openings; do not even open them. The nozzle filters however may be cleaned or replaced as required.

It is advisable to replace nozzles every year during regular maintenance operations.

Combustion must be checked after the nozzles have been changed.

Fuel tank

If water or contamination is present within the fuel tank, it is essential that this is removed before the equipment is to be used. This is extremely important when gas oil containing Bio diesel is in use. If in doubt about how to achieve this then please contact the fuel or oil tank supplier.

Combustion

In case the combustion values found at the beginning of the intervention do not respect the standards in force or, in any case, do not correspond to a proper combustion, contact the Technical Assistant and have him carry out the necessary adjustments.

EN 267	Excess air		
	Max output $\lambda \leq 1.2$		Min output $\lambda \leq 1.3$
Theoretical max. CO ₂ 0 % O ₂	Calibration CO ₂ %		CO mg/kWh
	$\lambda = 1,2$	$\lambda = 1,3$	
15.2	12.6	11.5	≤ 100

GAS OPERATION

Gas leaks

Make sure that there are no gas leaks on the pipework between the gas meter and the burner.

Gas filter

Change the gas filter when it is dirty.

Combustion

In case the combustion values found at the beginning of the intervention do not respect the standards in force or, in any case, do not correspond to a proper combustion, consult the under mentioned table, contact the Technical Assistant and have him carry out the necessary adjustments.

EN 676		Excess air		
		Max output $\lambda \leq 1.2$		Min output $\lambda \leq 1.3$
GAS	Theoretical max. CO ₂ 0 % O ₂	Calibration CO ₂ %		CO mg/kWh
		$\lambda = 1.2$	$\lambda = 1.3$	
G 20	11.7	9.7	9.0	≤ 100
G 25	11.5	9.5	8.8	≤ 100
G 30	14.0	11.6	10.7	≤ 100
G 31	13.7	11.4	10.5	≤ 100

7.3 Opening the burner



Disconnect the electrical supply from the burner by means of the main system switch.



Turn off the fuel interception tap.



Wait for the components in contact with heat sources to cool down completely.

- Remove the tie rods 1) and 6)(Fig. 44) of the head movement and damper opening lever by loosening nuts 2).
- Disconnect servomotor socket 3).
- Disconnect derivation unit socket 7).
- Disconnect the gas pressure switch socket 4).
- Remove screws 5).
- At this point it is possible to open the burner at the hinge.

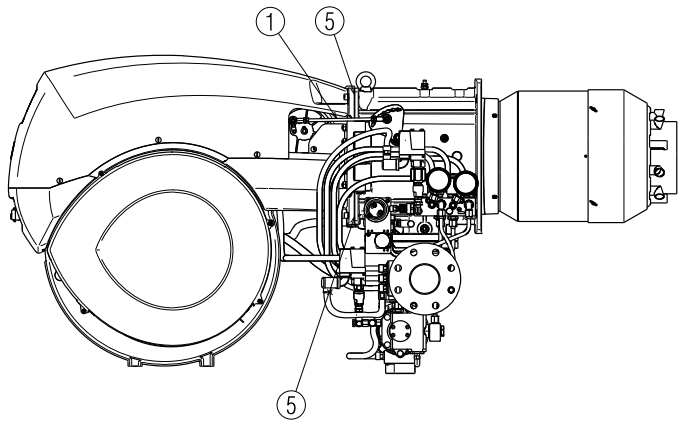
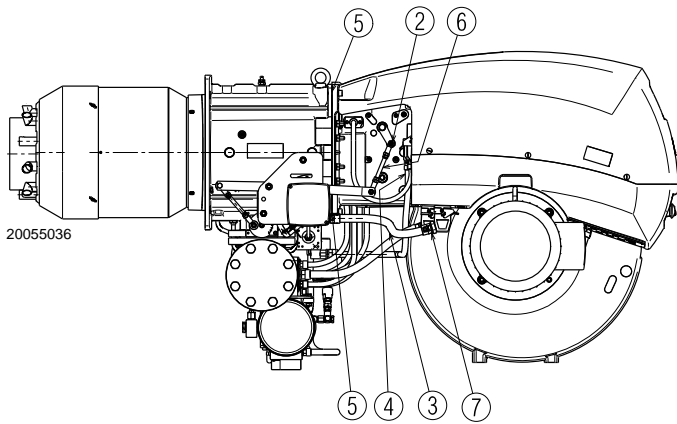

Fig. 44

7.4 Closing the burner

Refit following the steps described but in reverse order; refit all burner components as they were originally assembled.



After carrying out maintenance, cleaning or checking operations, reassemble the hood and all the safety and protection devices of the burner.

8 Faults - Probable causes - Solutions

The LFL1.333... control box is equipped with a lockout indicator (Fig. 45) that turns during the start-up programme, and is visible from the small lockout window.

When the burner does not start or stops, due to a failure, the symbol that appears on the indicator indicates the type of interruption.

The positions of the lockout indicator are shown in Fig. 46.

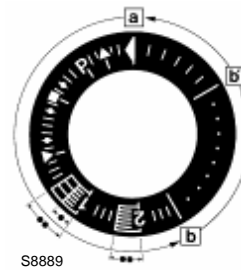

Lockout indicator

- a-b Start-up sequence
- b-b' Idle stages (without contact confirmation)
- b(b')-a Post-purging programme

Fig. 45

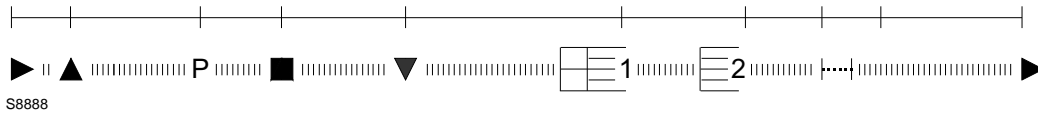

Fig. 46

Fuse replacement

The fuse 2)(Fig. 47) is in the rear part of the control box. A spare fuse 1) is also available: it can be extracted after breaking the panel tab A) that houses it. In the event that fuse 2) has been tripped, replace it as shown in Fig. 47.

Find a list of faults, causes and possible solutions for a set of failures that may occur and result in irregular burner operation or no functioning at all.

If a burner malfunction is detected, first of all:

- check that the electrical wiring is adequately connected;
- check whether fuel is delivered;
- check that every adjustment parameter is adequately set.

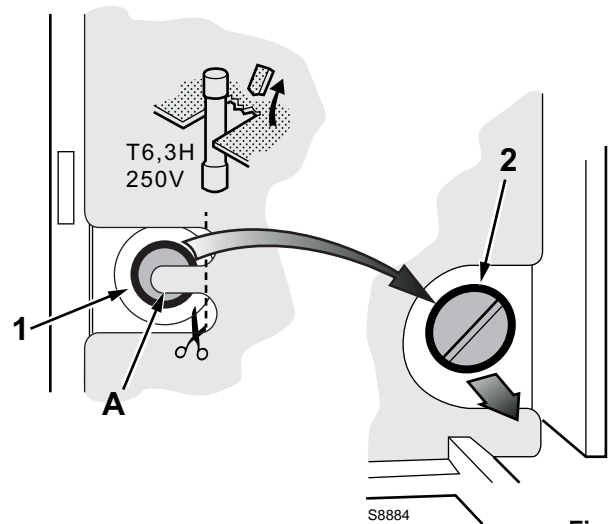

Fig. 47



WARNING

In the event of a burner lockout, more than two consecutive burner reset operations could cause damage to the installation. On the third lockout, contact the Aftersales Service.



DANGER

If further lockouts or burner faults occur, interventions must only be made by qualified, authorised personnel (as indicated in this manual, and in compliance with the laws and regulations currently in force).

8.1 Light oil operation

Symbol	Problem	Possible cause	Recommended remedy
◀	The burner does not start	Limiter or safety control device open	Adjust or replace
		Control box lockout	Release
		Fan motor lockout	Release the thermal relay
		Intervention of maximum oil pressure switch	Adjust the pressure switch or eliminate overpressure
		No electrical power supply	Close all switches - check connections
		No light oil	Check the light oil supply circuit
		Control box fuse interrupted	Replace
		Pump is jammed	Replace
		Faulty motor remote control switch	Replace
		Defective control box	Replace
		Faulty electrical motor	Replace
		The pilot burner does not work	Check
		Defective safety solenoid valve	Replace
	Faulty oil modulator	Recondition or replace it	
	The burner does not switch on, and the lock-out appears	Flame simulation	Replace the control box
Photocell short-circuit		Replace photocell	
Two-phase electrical supply, thermal relay steps in		Reset the thermal relay at return of the three phases	
▲	The burner starts but stops at maximum air damper setting	Contact 1 of the servomotor terminals 9-8 control box does not intervene	Adjust cam I or replace servomotor
P	The burner switches on, but then stops in lockout	Air pressure switch incorrectly adjusted	Adjust it
		Pressure switch pressure point pipe blocked	Clean
■	The burner switches on, but then stops in lockout	Failure to the flame detection circuit	Replace control box
▼	The burner remains in pre-purging phase	Contact III of the servomotor terminals 10-8 control box does not intervene	Adjust cam III or replace servomotor
1	Once the pre-purging and the safety time has elapsed the burner goes into lockout without the flame appearing	The VP1 solenoid lets too little gas through	Increase
		The solenoid VP1 or VP2 does not open	Replace the coil or the rectifier panel
		No fuel in the tank, or water on the bottom	Refill with fuel, or remove the water
		Bad head and damper adjustments	Adjust
		Faulty or grounded high voltage cable	Replace
		High voltage cable deformed by high temperature	Replace and protect
		Bad electrical wiring on valves or transformer	Check
		Pump unprimed	Prime it
		Pump suction line connected to return line	Correct connection
		Soiled filters (nozzle line)	Clean
		The valves upstream from the pump are closed	Open them
		Opposite motor rotation	Change electrical wiring to the motor
		Light oil solenoids do not open	Check connections and solenoids
		Nozzle clogged, soiled or deformed	Clean it or replace it
		Pilot burner does not work	Check
		Defective control box	Replace
		Ignition electrode incorrectly adjusted	Adjust it
		Electrode grounded due to broken insulation	Replace
		Motor/pump coupling broken	Replace
	Faulty ignition transformer	Replace	
	The flame ignites regularly but the burner goes into lock out at the end of the safety time	Faulty photocell or control box	Replace photocell or control box
Soiled photocell		Clean	

Symbol	Problem	Possible cause	Recommended remedy
	Smoke in flame (dark Bacharach)	Little air	Adjust the fan head and damper
		Incorrect pump pressure	Adjust
		Nozzle filter clogged	Clean or replace
		Insufficient boiler room ventilation openings	Increase
		Dirty or worn nozzle	Replace
		Flame disk soiled, loose or deformed	Clean it, tighten it or replace it
	Smoke in flame (yellow Bacharach)	Excessive air	Adjust head and air dampers
	Ignition with pulses or flame failure, delayed ignition	Poorly adjusted head	Adjust
		Incorrectly adjusted fan air damper: too much air	Adjust
		Nozzle not fit for burner or boiler	See the nozzle table
		Faulty nozzle	Replace
		Unsuitable pump pressure	Adjust
		Ignition electrode not adjusted correctly or soiled	Adjust it
		Output during ionisation phase is too high	Reduce
	The burner does not pass to 2° stage	Remote control device TR fails to close	Adjust or replace
		Defective control box	Replace
	Uneven fuel supply	Understand whether the cause lies in the pump or the fuel supply system	Supply fuel to the burner from a tank positioned near the burner itself
	Internally rusted pump	Water in the tank	Remove the water with a pump
	Noisy pump, unstable pressure	Air in the suction line	Block the couplings
		Depression value too high (higher than 35 cm Hg):	
		Excessive difference of level between burner and tank	Power the burner from a loop circuit
		Piping diameter too small	Increase
		Dirty suction line filters	Clean
		Suction line valves closed	Open them
		The paraffin solidifies due to the low temperature	Put additive in the light oil
	Pump unprimes after prolonged pause	Return pipeline not immersed in the fuel	Bring it to the same height as the suction line
		Air in the suction line	Block the couplings
	Pump leaks light oil	Loss of sealing organ	Replace the pump
	Dirty combustion head	Dirty nozzle or nozzle filter	Replace
		Unsuitable nozzle delivery or angle	See recommended nozzles
		Loose nozzle	Block it
		Environmental impurities on flame stability disc	Clean
		Incorrect head adjustment, or little air	Adjust it, opening the damper
		Blast tube length not suitable for the boiler	Contact the boiler manufacturer
I	Burner goes into lockout during operation	Photocell faulty or soiled	Replace it or clean it
		Air pressure switch faulty	Replace

Tab. O

8.2 Gas operation

Symbol	Problem	Possible cause	Recommended remedy
◀	The burner does not start	No electrical power supply	Close all switches and check connections
		A limit or safety thermostat/pressure switch open	Adjust or replace
		Control box lockout	Release the control box
		Control box fuse interrupted	Replace it (2)
		Incorrect electrical wiring	Check
		Defective control box	Replace
		No gas supply	Open the manual valves between meter and train
		Mains gas pressure insufficient	Contact your GAS COMPANY
		Minimum gas pressure switch fails to close	Adjust or replace
		Air pressure switch in operating position	Adjust or replace
	The servomotor contact does not intervene (closure cam 0°)	Adjust the closure cam 0° or replace the servomotor	
	The burner does not switch on, and the lock-out appears	Flame simulation	Replace the control box
		Faulty motor remote control switch	Replace
		Defective electrical motor	Replace
Motor lockout		Release the thermal relay	
▲	The burner starts up but stops at the damper maximum opening	The servomotor contact does not intervene (maximum cam opening)	Cam adjustment (maximum opening) or replace the servomotor
P	The burner starts and then goes into lockout	Air pressure switch inoperative due to insufficient air pressure:	
		Air pressure switch poorly adjusted	Adjust or replace
		Pressure switch pressure point pipe blocked	Clean
		Poorly adjusted head	Adjust
		Dirty fan	Clean
		High depression in the furnace	Contact our Technical Department
■	The burner turns on and then remains in lockout mode	Failure to the flame detection circuit	Replace the control box
▼	The burner remains in the pre-purge phase	The servomotor contact does not intervene (cam minimum)	Cam adjustment (minimum) or replace the servomotor
1	Once the pre-purging and the safety time has elapsed the burner goes into lockout without the flame appearing	The VP1 solenoid lets too little gas through	Increase
		The solenoid VP1 or VP2 does not open	Replace the coil or the rectifier panel
		Gas pressure too low	Increase pressure at governor
		Ignition electrode incorrectly adjusted	Adjust it
		Electrode grounded due to broken insulation	Replace
		Faulty or grounded high voltage cable	Replace
		High voltage cable deformed by high temperature	Replace and protect
		Faulty ignition transformer	Replace
		Incorrect valve or ignition transformer connections	Redo them
		Defective control box	Replace
		A closed valve upline the gas train	Open
		Air in pipework	Bleed air
	Lockout with flame appearing	The VP1 or VP2 solenoids let too little gas through	Increase
		Dirty flame sensor	Check, replace flame sensor
		Faulty connection	Check, replace flame sensor
		Insufficient detection current (min.70 µA)	Measure current, replace flame sensor
		Flame sensor exhausted, faulty	Replace
		Maximum gas pressure switch intervention	Adjust or replace
Defective control box	Replace		

Symbol	Problem	Possible cause	Recommended remedy
	The burner continues to repeat the start-up cycle, without lockout	The gas pressure in the gas mains lies very close to the value to which the minimum gas pressure switch has been set. The sudden drop in pressure after valve opening causes temporary opening of the pressure switch itself, the valve immediately closes and the burner comes to a halt. Pressure increases again, the pressure switch closes again and the ignition cycle is repeated. The sequence repeats endlessly.	Reduce the minimum gas pressure switch intervention pressure. Replace the gas filter cartridge
	Lockout without symbol indication	Flame simulation	Replace the control box
	Burner goes into lockout during operation	Faulty flame sensor	Replace worn parts
		Air pressure switch faulty	Replace
		Maximum gas pressure switch intervention	Adjust or replace
◀	Lockout when the burner stops	Permanent flame in the combustion head or flame simulation	Eliminate permanency of flame or replace the control box
	Ignition with pulsations	Poorly adjusted head	Adjust
		Ignition electrode incorrectly adjusted	Adjust it
		Incorrectly adjusted fan air damper: too much air	Adjust
		Output during ionisation phase is too high	Reduce

Tab. P

A Appendix - Accessories

Output power regulator kit for modulating operation

With the modulating operation, the burner continually adapts the power to the request for heat, ensuring great stability for the parameter controlled: temperature or pressure.

Two components should be ordered:

- the output regulator to install on the burner
- the probe to install on the heat generator

Parameter to control		Probe		Output power regulator	
	Range	Type	Code	Type	Code
Temperature	- 100...+ 500°C	PT 100	3010110	RWF50.2 RWF50.5	20101190
Pressure	0...2.5 bar	Probe with output 4...20 mA	3010213		20101191
	0...16 bar		3010214		

Output power regulator with signal 4-20 mA, 0-10V

Two components should be ordered:

- the analogic signal converter;
- the Potentiometer

Potentiometer		Analogic signal converter	
Type	Code	Type	Code
ASZ...	3010402	E5202	3010390

Sound proofing box

If noise emission needs reducing even further, sound-proofing boxes is available.

Burner	Box type	Average noise reduction [dB(A)]	Code
RLS 800/M MX	C7	10	3010376

Degassing unit

It may occur that a certain amount of air is contained in the fuel sucked up by the pump.

This air may originate from the fuel itself as a consequence of de-pressurisation or air leaking past imperfect seals.

In double-pipe systems, the air returns to the tank from the return pipe; in single-pipe systems, the air remains in circulation causing pressure variations in the pump and burner malfunctions.

For this reason, we advise installing a degassing unit near the burner in single-pipe installations.

Degassing units are provided in two versions:

Burner	Code
RLS 800/M MX (without filter)	20034277
RLS 800/M MX (with filter)	20034281

Degassing unit characteristics

Burner output	80 kg/h max
Fuel pressure	0.7 bar max
Ambient temperature	40 °C max
Fuel temperature	40 °C max
Attachment connectors (without filter)	FF G 1/4 tank side FM G 3/8 conic burner side
Attachment connectors (with filter)	FF G 3/8 tank side FM G3/8 conic burner side

Fuel remote selection kit

Burner	Code
RLS 800/M MX	3010372

Spacer kit

If burner head penetration into the combustion chamber needs reducing, varying thickness spacers are available, as given in the following table.

Burner	Code
RLS 800/M MX	20008903

Gas trains approved according to EN 676

Refer to the instruction manual.

B Appendix - Electrical panel layout

1	Index of layouts
2	References layout
3	Layout of unifilar output
4	Operational layout star-powered starter/delta-powered starter
5	Operational layout LFL 1...
6	Operational layout LFL 1...
7	Operational layout LFL 1...
8	Operational layout LFL 1...
9	Operational layout RWF50...
10	Electrical connections set by installer
11	Electrical connections for internal RWF50 kit
12	Electrical connections for external RWF50 kit

2 Reference layout



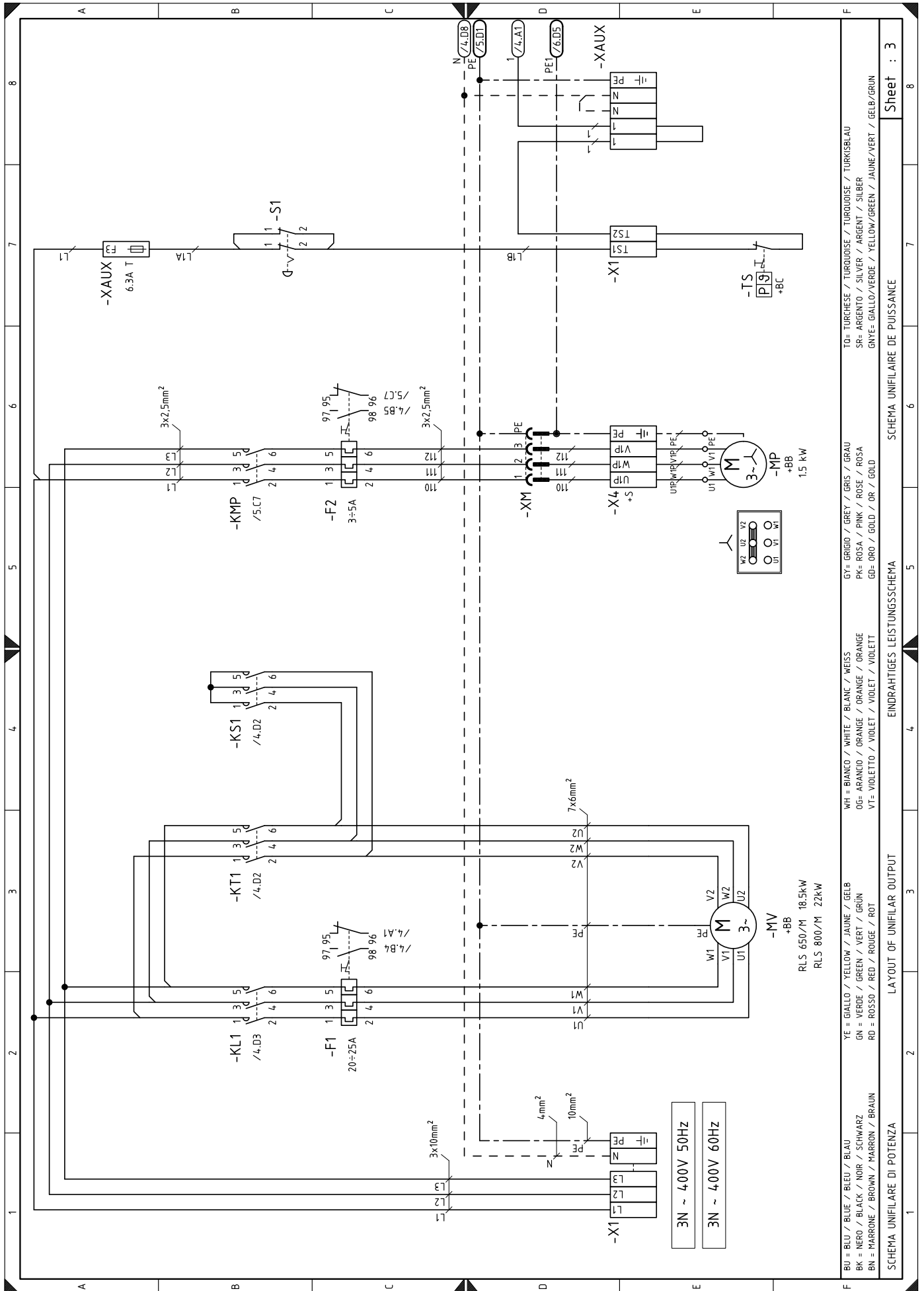

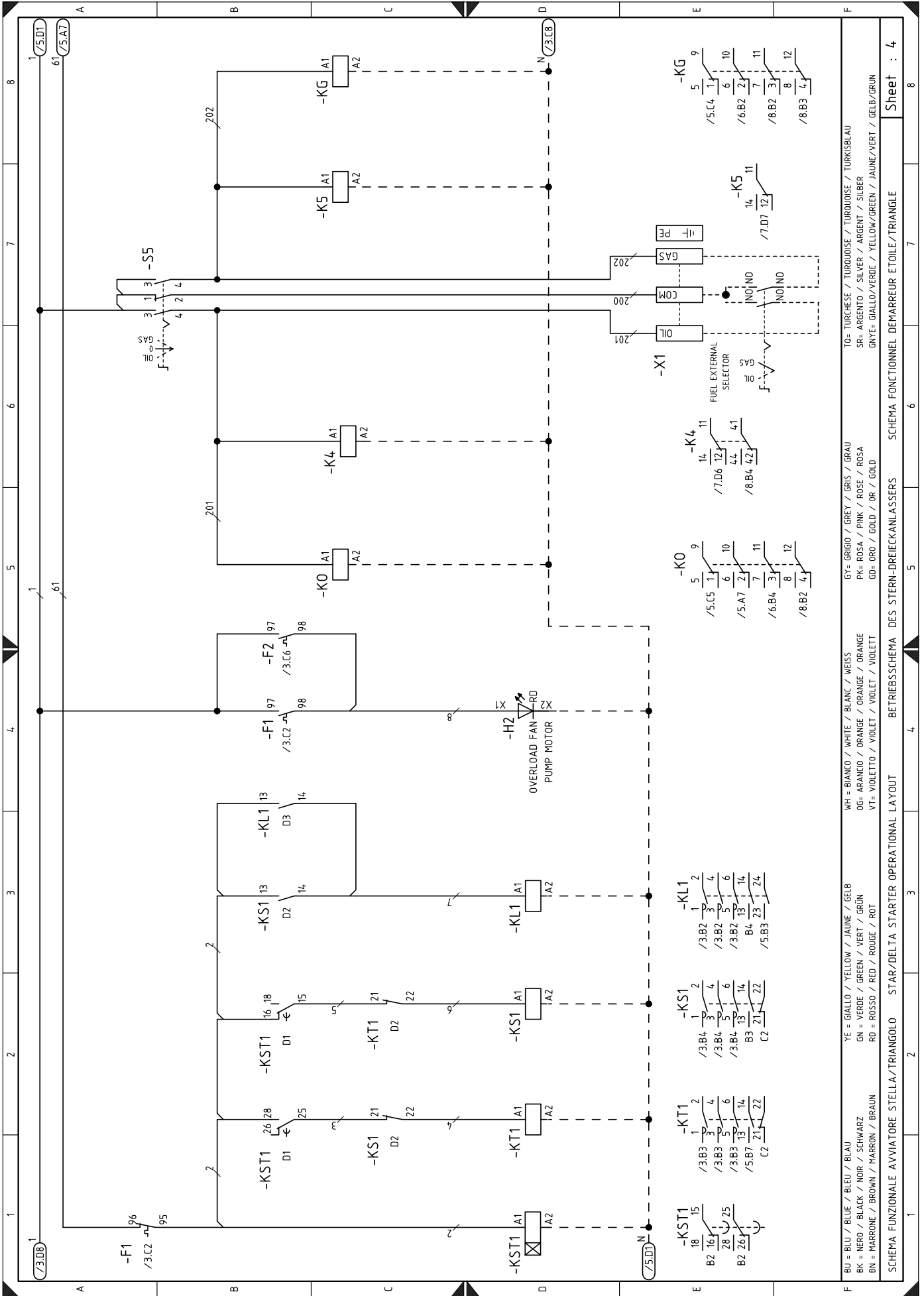

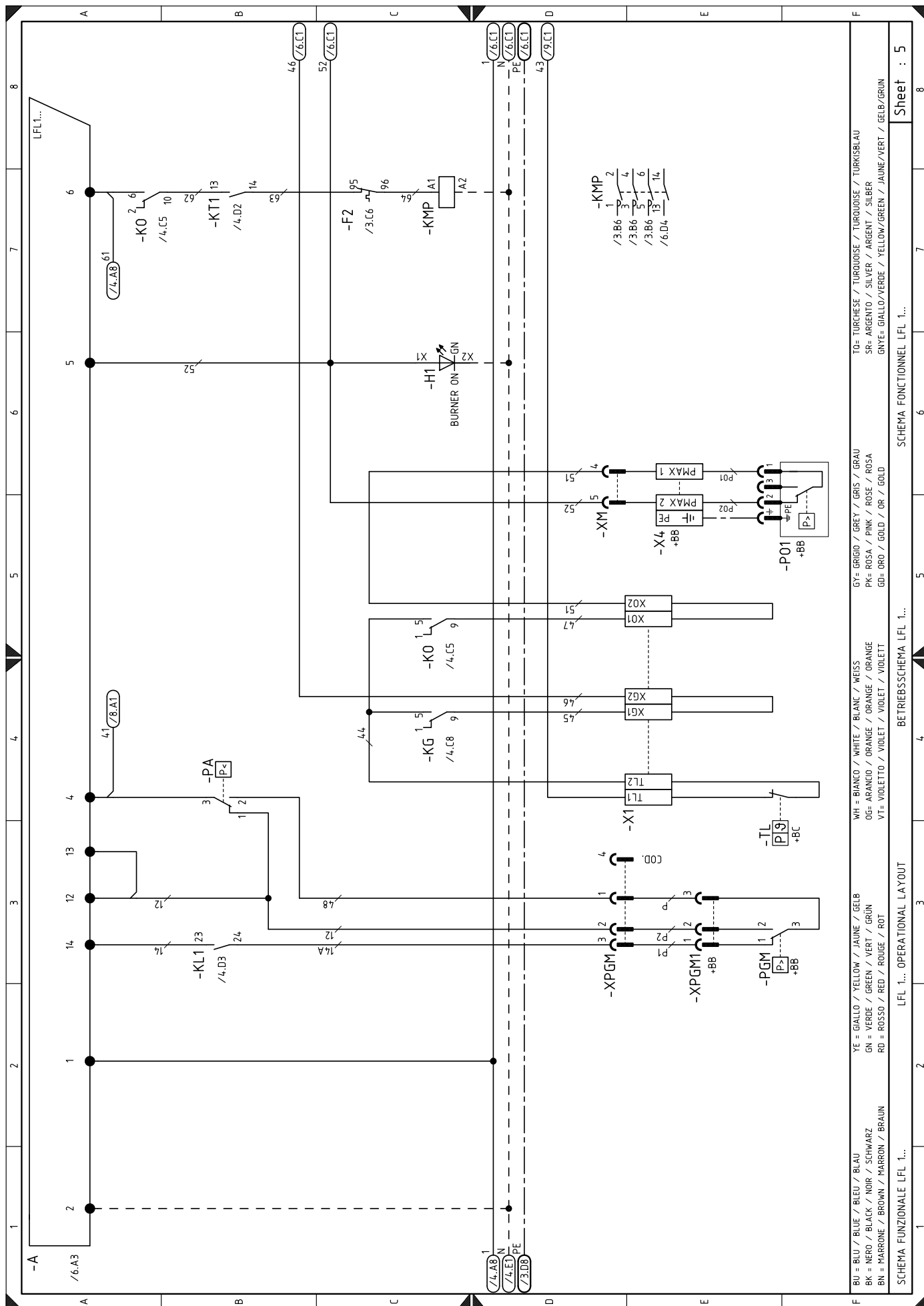

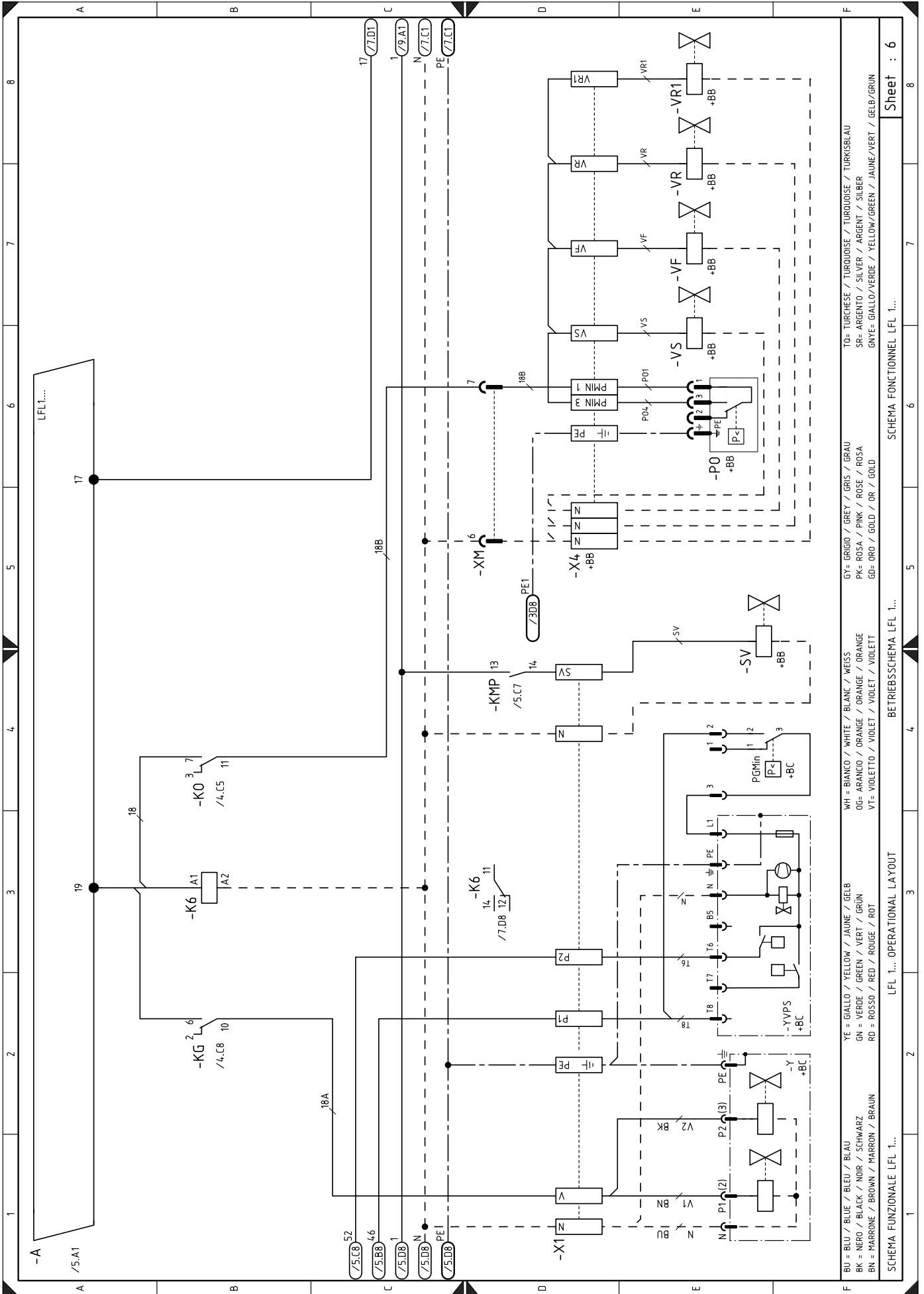

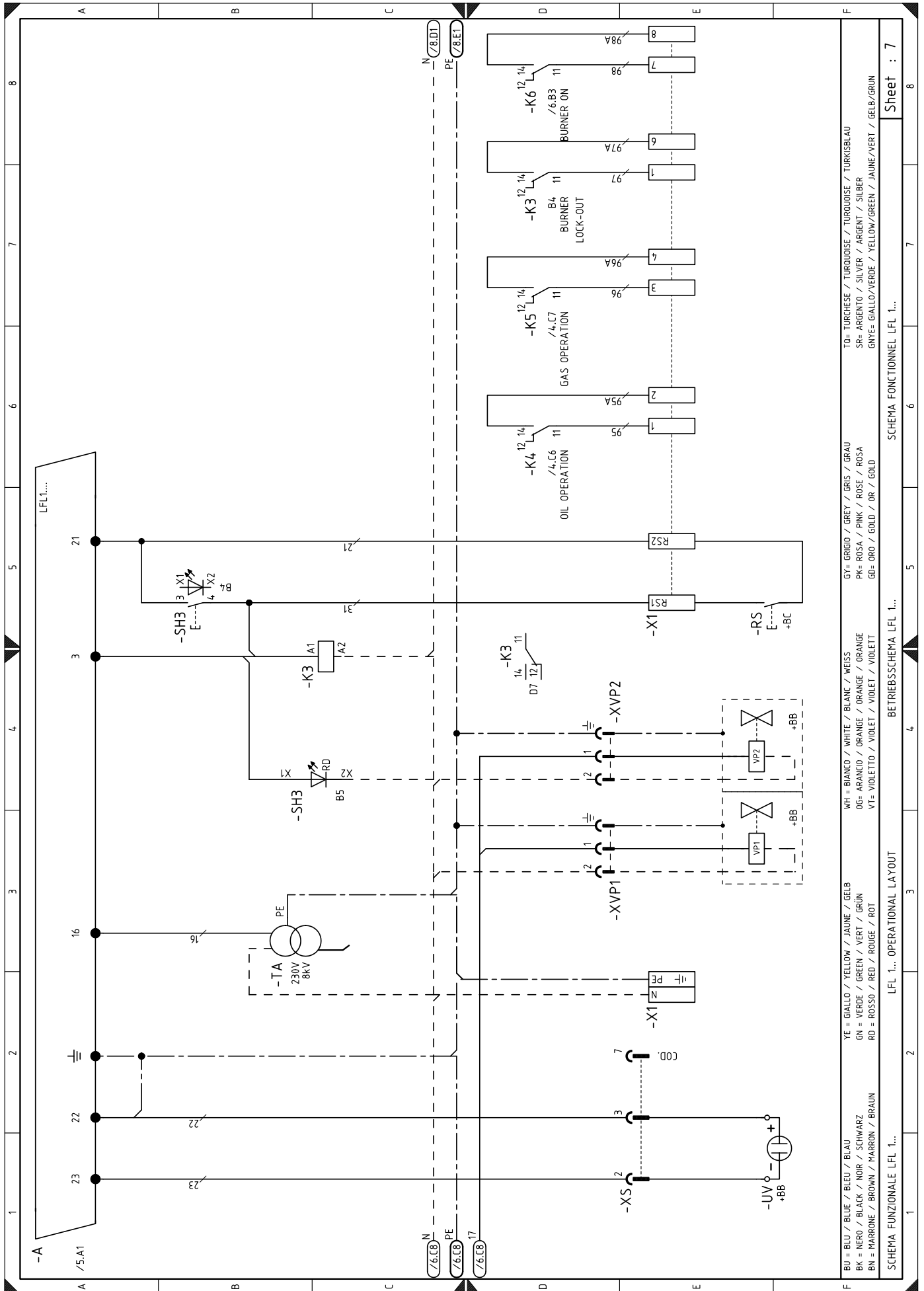

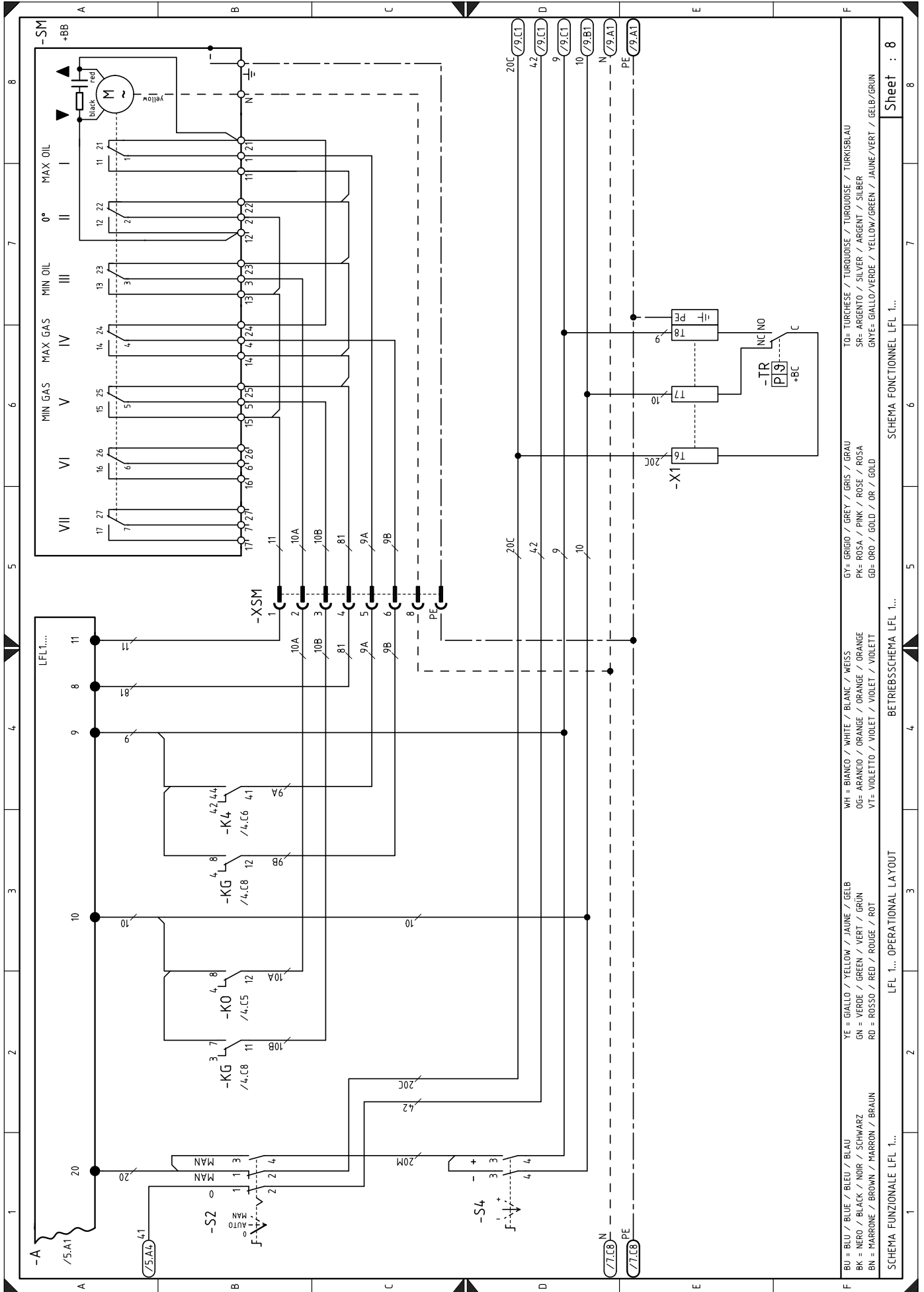

Sheet : 8

SCHEMA FONCTIONNEL LFL 1...

BETRIEBSSCHEMA LFL 1...

LFL 1... OPERATIONAL LAYOUT

SCHEMA FUNZIONALE LFL 1...

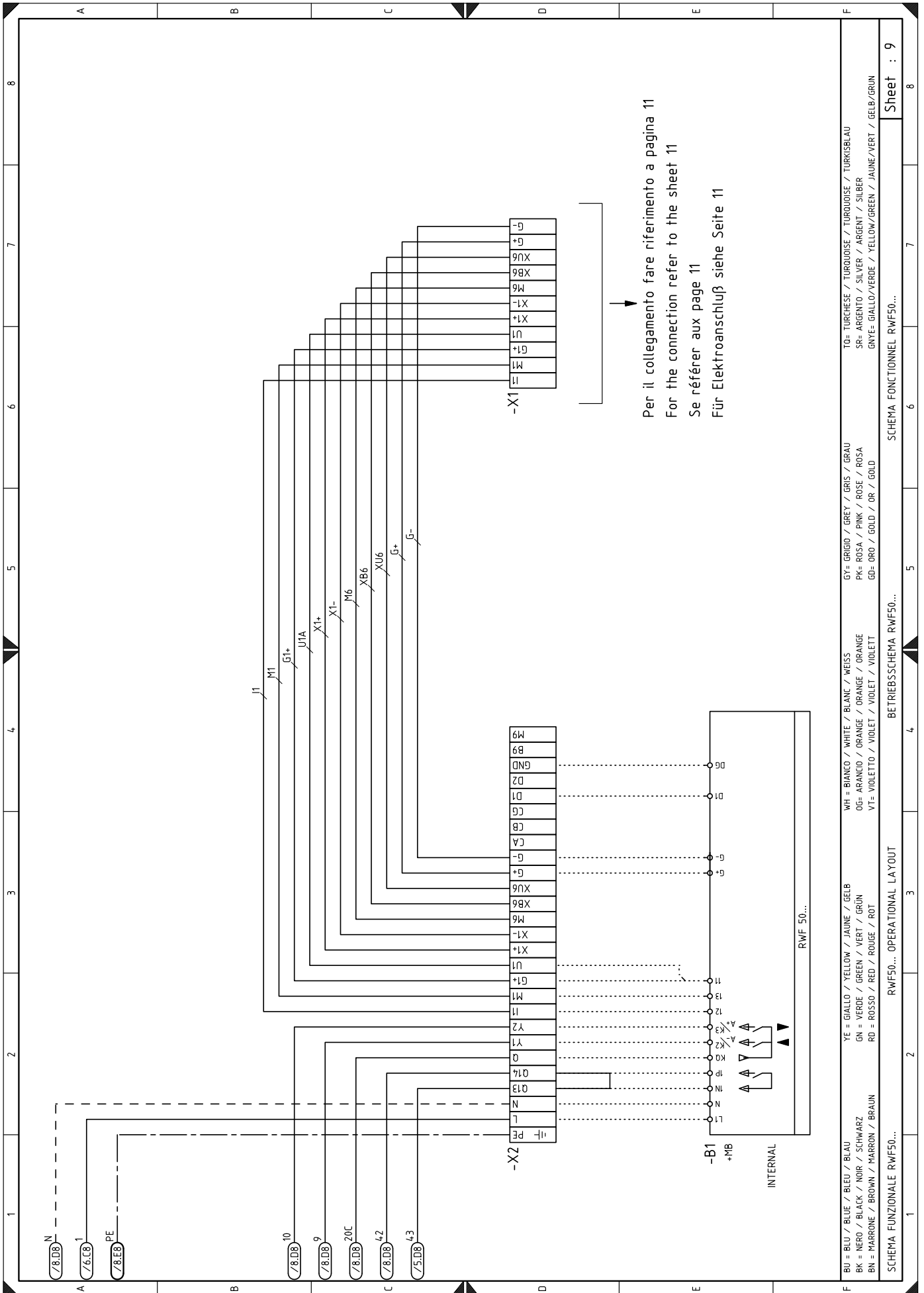

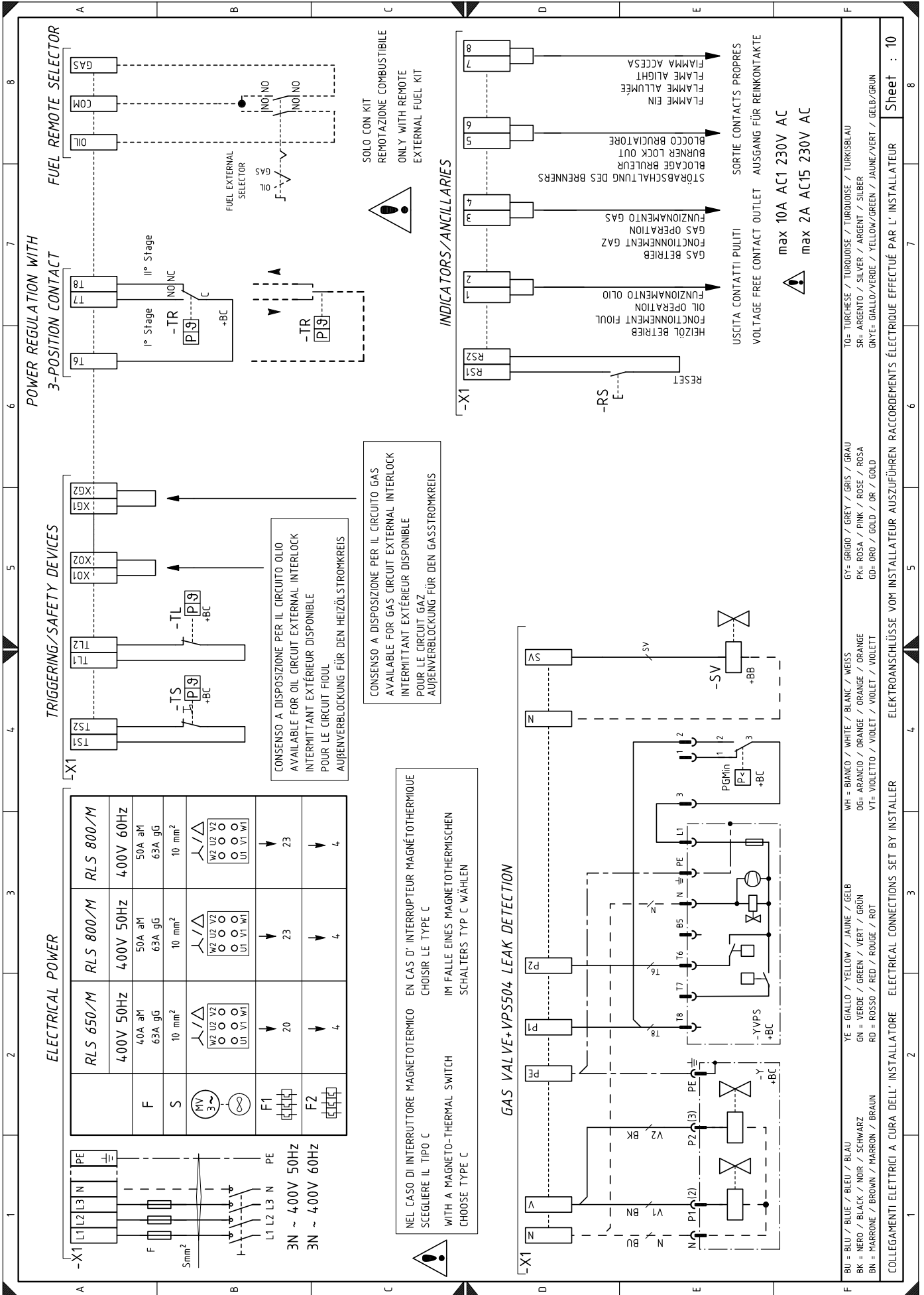

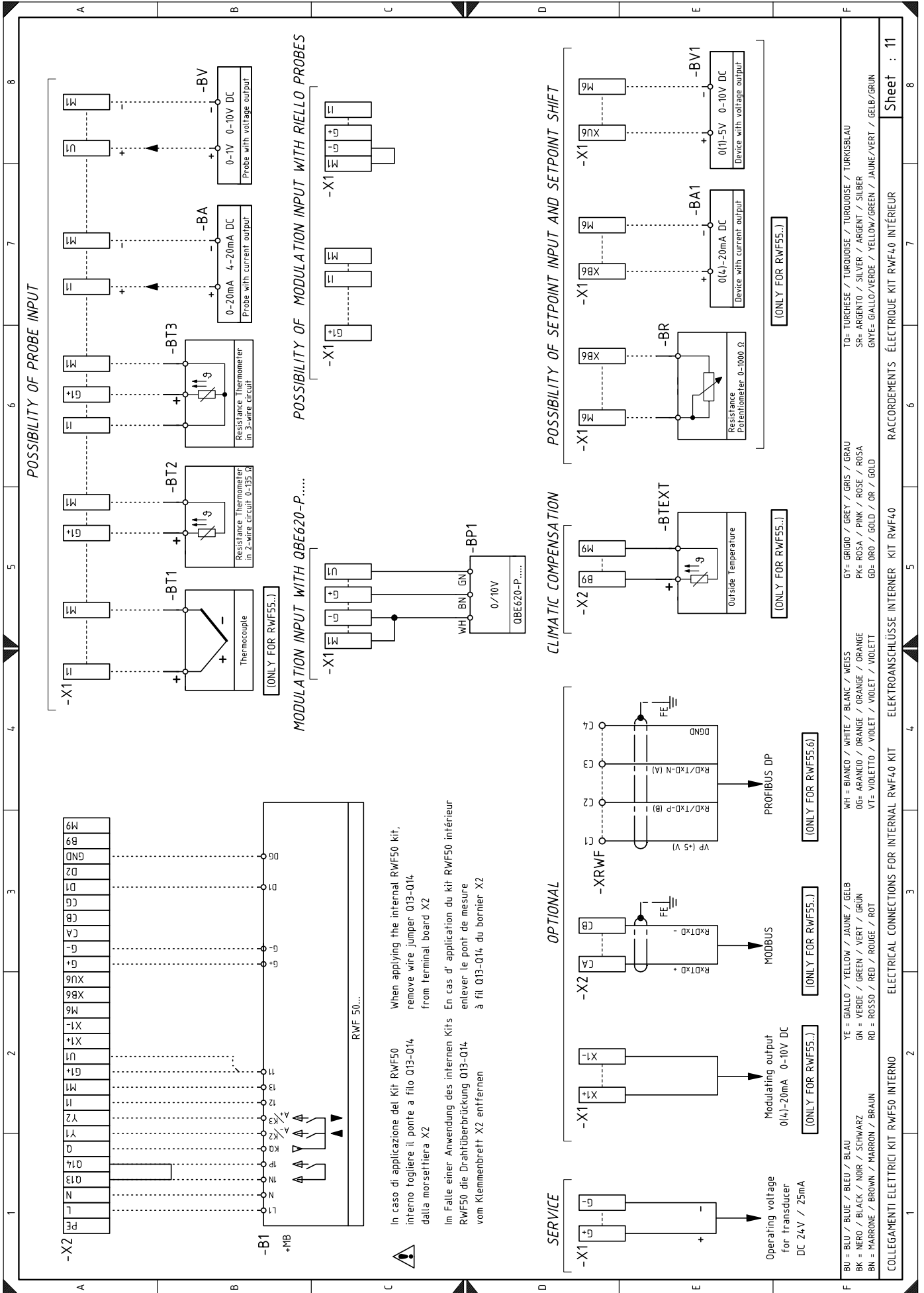

In caso di applicazione del Kit RWF50 interno togliere il ponte a filo Q13-Q14 dalla morsettiere X2
 When applying the internal RWF50 kit, remove wire jumper Q13-Q14 from terminal board X2
 Im Falle einer Anwendung des internen Kits RWF50 die Drahtüberbrückung Q13-Q14 vom Klemmbrett X2 entfernen
 En cas d'application du kit RWF50 intérieur enlever le pont de mesure à fil Q13-Q14 du bornier X2

BU = BLU / BLUE / BLEU / BLAU BK = NERO / BLACK / NOIR / SCHWARZ BN = MARRONE / BROWN / MARRON / BRAUN	YE = GIALLO / YELLOW / JAUNE / GELB GN = VERDE / GREEN / VERT / GRÜN RD = ROSSO / RED / ROUGE / ROT	WH = BIANCO / WHITE / BLANC / WEISS OG = ARANCIO / ORANGE / ORANGE / ORANGE VT = VIOLETTA / VIOLET / VIOLET / VIOLETT	GY = GRIGIO / GREY / GRIS / GRAU PK = ROSA / PINK / ROSE / ROSA GD = ORO / GOLD / OR / GOLD	TO = TURCHESE / TURQUOISE / TURKISBLAU SR = ARGENTO / SILVER / ARGENT / SILBER GNYE = GIALLO/VERDE / YELLOW/GREEN / JAUNE/VERT / GELB/GRÜN	Sheet : 11
--	---	---	---	--	-------------------

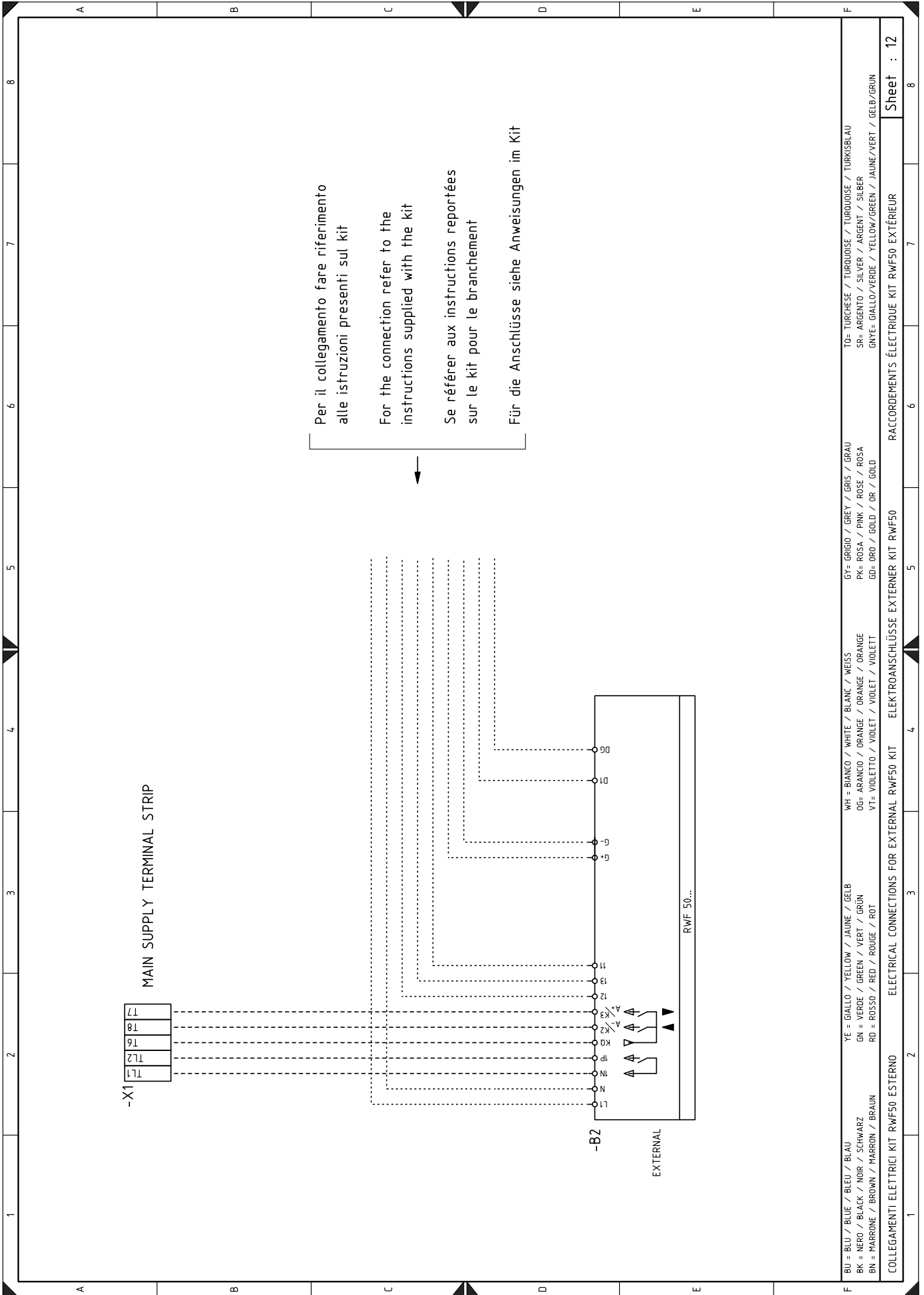

Wiring layout key

A	Control box	TS	Safety pressure switch/thermostat
B1	Internal output power regulator RWF	UV	Flame sensor
B2	External output power regulator RWF	VF	Light oil operation valve
BA	Probe with current output	VP1	Pilot valve 1
BA1	Device with current output for editing remote setpoint	VP2	Pilot valve 2
BP	Pressure probe	VR	Light oil return valve
BP1	Pressure probe	VR1	Light oil return valve
BR	Remote setpoint voltage divider	VS	Light oil safety valve
BT1	Thermocouple probe	X1	Main supply terminal strip
BT2	Probe Pt100 with 2 wires	X2	RWF terminal strip
BT3	Probe Pt100 with 3 wires	X4	Light oil assembly terminal block
BT4	Probe Pt100 with 3 wires	XAUX	Auxiliary terminal strip
BTEXT	External probe for the climatic compensation of the setpoint	XM	Light oil assembly connector
BV	Probe with voltage output	XPGM	Maximum gas pressure switch connection plug
BV1	Device with voltage output for editing remote setpoint	XPGM1	Minimum gas pressure switch connection plug
F1	Fan motor thermal cut-out	XRWF	Output power regulator RWF terminal strip
F2	Pump motor thermal cut-out	XS	Flame detectors connector
F3	Auxiliary fuse	XSM	Air and gas servomotors connector
H1	Signal light for burner on	XVP1	Pilot valve 1 connector
H2	Signal light for fan and pump motors trip	XVP2	Pilot valve 2 connector
KL1	Direct start and star/delta starter line contactor	Y	Gas adjustment valve + gas safety valve
KMP	Pump motor contactor	YVPS	Gas valve leak detection control device
KT1	Star-powered/delta-powered starter /delta contactor		
KS1	Star-powered/delta-powered starter /star-powered contactor		
KST1	Star-powered/delta -powered starter timer		
K3	Burner lock-out voltage free contact relay		
K4	Light oil operation voltage free contact relay		
K5	Gas operation voltage free contact relay		
K6	Fuelled burner ON clean contacts output relay		
KG	Gas operation relay		
KO	Light oil operation relay		
MP	Pump motor		
MV	Fan motor		
PA	Air pressure switch		
PE	Burner ground (earth) connection		
PGM	Maximum gas pressure switch		
PGMin	Minimum gas pressure switch		
PO	Oil pressure switch		
PO1	High-limit oil pressure switch on return line		
RS	Remote lock-out reset button		
S1	Emergency stop push-button		
S2	Dial for off - automatic - manual		
S4	Power dial for increase - decrease of power		
S5	Fuel selector and remote fuel selector enabling		
SH3	Burner reset button and lockout warning		
SM	Servomotor		
SV	Main safety valve		
TA	Ignition transformer		
TL	Limit pressure switch/thermostat		
TR	Control pressure switch/thermostat		

RIELLO

RIELLO S.p.A.
I-37045 Legnago (VR)
Tel.: +39.0442.630111
[http:// www.riello.it](http://www.riello.it)
[http:// www.riello.com](http://www.riello.com)