

GB **Kerosene burners**

One stage operation



CODE	MODEL	TYPE
3516010	RDB1 WORCESTER GREENSTAR 12/18	484LD2X
3516020	RDB2.2 WORCESTER GREENSTAR 18/25	744LD2SX
20015255	RDB2.2 WORCESTER GREENSTAR 25/32	744T2K



Original instructions

1	Declaration	3
2	Information and general warnings	4
2.1	Information about the instruction manual	4
2.1.1	Introduction	4
2.1.2	General dangers	4
2.1.3	Other symbols	4
2.1.4	Delivery of the system and the instruction manual	5
2.2	Guarantee and responsibility	5
2.3	Guidance for the use of bio fuel blends up to 10% where gas oil use is permitted by the appliance Manufacturer	6
2.3.1	Information and general instructions	6
2.3.2	Product Disclaimer Statement	6
3	Safety and prevention	7
3.1	Introduction	7
3.2	Safety warnings	7
3.3	Basic safety rules	7
3.4	Personnel training	7
4	Technical description of the burner	8
4.1	Technical data	8
4.2	Burner description	8
4.3	Burner equipment	8
4.4	Burner dimensions	9
4.5	Firing rates	9
5	Installation	10
5.1	Notes on safety for the installation	10
5.2	Handling	10
5.3	Preliminary checks	10
5.4	Installer/Service notes for the use of Gas oil with Bio blends up to 10% where gas oil use is permitted by the appliance Manufacturer	11
5.5	Working position	11
5.6	Boiler fixing	12
5.7	Burner assembly	12
6	Hydraulic systems	13
6.1	Fuel supply	13
6.1.1	Pump	13
6.2	One pipe system	14
6.2.1	Priming pump	14
6.3	Two pipe system	15
6.3.1	Priming pump	15
7	Electrical system	16
7.1	Notes on safety for the electrical wiring	16
7.1.1	Control box	16
7.1.2	Motor capacitor	17
7.2	Electrical wiring	18
8	Start-up, calibration and operation of the burner	19
8.1	Notes on safety for the first start-up	19
8.2	Combustion adjustment	19
8.3	Nozzles installation	19
8.3.1	Nozzles recommended	19
8.4	Pump pressure	19
8.5	Electrodes setting	20
8.6	Air damper adjustment	20

8.6.1	Main air damper	20
8.6.2	Secondary air damper	20
8.7	Operation programme	21
8.8	Table of timings	22
8.8.1	Operations status indication	22
8.8.2	Faults diagnosis - lockouts	22
8.8.3	Fuel pre-heating function (for burners equipped with heater)	23
8.8.4	Shutdown test	23
8.8.5	Diagnosis of the flame signal quality	23
8.8.6	Intermittent operation	23
8.8.7	Recycle and limit of repetitions	23
8.8.8	Presence of an extraneous light or parasite flame	23
8.8.9	Pre and post spark ignition	23
8.8.10	Reset protection and remote reset	23
8.8.11	Reset push-button anomaly	23
8.8.12	External lockout indicator	24
8.8.13	Frequency main supply anomaly	24
8.8.14	Internal voltage anomaly	24
8.8.15	Checking the fan motor	24
8.8.16	Checking the electronic circuit controlling the oil valve	24
8.8.17	EEPROM check	24
8.9	Automatic pre-heating deactivation (for burners equipped with heater)	24
8.10	Programming menu	25
8.10.1	Shutdown test	25
8.10.2	Light diagnosis	25
8.10.3	Intermittent operation	25
8.10.4	Display of the last lockout that occurred	26
8.11	Lockout types	26
9	Maintenance	27
9.1	Notes on safety for the maintenance	27
9.2	Maintenance programme	27
9.2.1	Maintenance frequency	27
9.2.2	Checking and cleaning	27
9.3	Opening the burner	28
10	Faults - Probable causes - Solutions	29

1 Information and general warnings

1.1 Information about the instruction manual

1.1.1 Introduction

The instruction manual supplied with the burner:

- is an integral and essential part of the product and must not be separated from it; it must therefore be kept carefully for any necessary consultation and must accompany the burner even if it is transferred to another owner or user, or to another system. If the manual is lost or damaged, another copy must be requested from the Technical Assistance Service of the area;
- is designed for use by qualified personnel;
- offers important indications and instructions relating to the installation safety, start-up, use and maintenance of the burner.

Symbols used in the manual

In some parts of the manual you will see triangular DANGER signs. Pay great attention to these, as they indicate a situation of potential danger.

1.1.2 General dangers

The **dangers** can be of **3 levels**, as indicated below.



Maximum danger level!
This symbol indicates operations which, if not carried out correctly, cause serious injury, death or long-term health risks.



This symbol indicates operations which, if not carried out correctly, may cause serious injury, death or long-term health risks.



This symbol indicates operations which, if not carried out correctly, may cause damage to the machine and/or injury to people.

1.1.3 Other symbols



DANGER: LIVE COMPONENTS
This symbol indicates operations which, if not carried out correctly, lead to electric shocks with lethal consequences.



DANGER: FLAMMABLE MATERIAL
This symbol indicates the presence of flammable materials.



DANGER: BURNING
This symbol indicates the risks of burns due to high temperatures.



DANGER: CRUSHING OF LIMBS
This symbol indicates the presence of moving parts: danger of crushing of limbs.



WARNING: MOVING PARTS
This symbol indicates that you must keep limbs away from moving mechanical parts; danger of crushing.



DANGER: EXPLOSION
This symbol signals places where an explosive atmosphere may be present. An explosive atmosphere is defined as a mixture - under atmospheric conditions - of air and flammable substances in the form of gases, vapours, mist or dust in which, after ignition has occurred, combustion spreads to the entire unburned mixture.



PERSONAL PROTECTION EQUIPMENT
These symbols indicate the equipment that must be worn and kept by the operator for protection against threats against safety and/or health while at work.



OBLIGATION TO ASSEMBLE THE HOOD AND ALL THE SAFETY AND PROTECTION DEVICES
This symbol signals the obligation to reassemble the hood and all the safety and protection devices of the burner after any maintenance, cleaning or checking operations.



ENVIRONMENTAL PROTECTION
This symbol gives indications for the use of the machine with respect for the environment.



IMPORTANT INFORMATION
This symbol indicates important information that you must bear in mind.

- This symbol indicates a list.

Abbreviations used

Ch.	Chapter
Fig.	Figure
Page	Page
Sec.	Section
Tab.	Table

1.1.4 Delivery of the system and the instruction manual

When the system is delivered, it is important that:

- the instruction manual is delivered to the user by the system manufacturer, with the recommendation to keep it in the room where the heat generator is to be installed.
- The instruction manual shows:
 - the serial number of the burner;

.....

- the address and telephone number of the nearest Assistance Centre

.....

.....

.....

- The system supplier must carefully inform the user about:
 - the use of the system;
 - any further tests that may be required before activating the system;
 - maintenance, and the need to have the system checked at least once a year by a representative of the manufacturer or another specialised technician.
 To ensure a periodic check, the manufacturer recommends the drawing up of a Maintenance Contract.

1.2 Guarantee and responsibility

The manufacturer guarantees its new products from the installation date, in accordance with the regulations in force and/or the sales contract. At the moment of the first start-up, check that the burner is integral and complete.



WARNING

Failure to observe the information given in this manual, operating negligence, incorrect installation and carrying out of non authorised modifications will result in the annulment by the manufacturer of the guarantee that it supplies with the burner.

In particular, the rights to the guarantee and the responsibility will no longer be valid, in the event of damage to things or injury to people, if such damage/injury was due to any of the following causes:

- incorrect installation, start-up, use and maintenance of the burner;
- improper, incorrect or unreasonable use of the burner;
- intervention of unqualified personnel;
- carrying out of unauthorised modifications on the equipment;
- use of the burner with safety devices that are faulty, incorrectly applied and/or not working;
- installation of untested supplementary components on the burner;
- powering of the burner with unsuitable fuels;
- faults in the fuel supply system;
- continuation of use of the burner when a fault has occurred;
- repairs and/or overhauls incorrectly carried out;
- modification of the combustion chamber with inserts that prevent the regular development of the structurally established flame;
- insufficient and inappropriate surveillance and care of those burner components most likely to be subject to wear and tear;
- the use of non-original components, including spare parts, kits, accessories and optional;
- force majeure.

The manufacturer furthermore declines any and every responsibility for the failure to observe the contents of this manual.

Riello warranty is subject to correct burner, appliance and application matching, and set up in line with Riello's instructions and guidelines. All components within the hydraulic circuit suitable for bio fuel use and supplied by Riello will be identified as Bio compatible. No warranty is given in relation to the use of components which are not so identified with bio fuel blends. If in any doubt please contact Riello for further advice.

If any Riello burners are used with fuel with a bio content >10% then the components within the hydraulic circuit maybe affected and are not covered under warranty.

The hydraulic circuit consists of:

- Pump
- Hydraulic ram (where applicable)
- Valve block
- Flexible oil lines (considered as a consumable component)

- 1 Irrespective of any warranty given by Riello in relation to normal use and manufacturing defects, when fuels not meeting the relevant standards are used, or where fuel storage issues have not been addressed correctly, or the equipment used is not compatible, if failures occur which are directly or indirectly attributed to such issues and/or to the non-observance of this guidance, then no warranty or liability is implied or accepted by Riello.
- 2 Riello have carefully chosen the specification of the bio compatible components including the flexible oil lines to protect the pump, safety valve and nozzle. The Riello warranty is dependent upon the use of Riello genuine components including the oil lines, being used.
- 3 Riello warranty does not cover defects arising from incorrect commissioning or servicing by non Riello employed service engineers, and any issues impacting the burner arising from external site related issues.

1.3 Guidance for the use of bio fuel blends up to 10% where gas oil use is permitted by the appliance Manufacturer

Background

With increasing focus on renewable and sustainable energy requirements, Bio fuel usage is set to increase. Riello is committed to promoting energy conservation and the use of renewable energy from sustainable resources including liquid bio fuels, however there are some technical aspects that must be considered at the planning stage of using such fuels to reduce the potential for equipment failure or the risks of fuel leakage.

Liquid Bio fuel is a generic description used for oil that can come from numerous feed stocks including recycled cooking oils. These types of oils have to be considered and treated differently from standard mineral or fossil fuels, as they are generally more acidic, hygroscopic and less stable.

Due to this, a holistic approach is needed from the specification of the liquid Bio fuel, the storage of the fuel, its oil supply line and ancillary equipment, and very importantly the oil filtration and the burner itself. The specification for FAME (Fatty Acids Methyl Ester) liquid Bio fuel is critical to reliable equipment operation.

It is a minimum requirement that the fuel blend (up to 10% Bio) is obtained with gasoil in accordance with the relevant EN standards, regional regulations and FAME in accordance with EN 14214. It is also important that the fuel blends meet the requirements related to operational environment conditions within the relevant EN standards.

When choosing your Riello oil products where you know Bio fuels will be in use, please make sure that a Bio compatible burner and/or components have been supplied. If an existing burner is to be used with a liquid Bio fuel then a kit may be required to make it compatible and the guidance notes enclosed concerning oil storage and filtration must be adhered to. The end user is responsible for the thorough verification of the potential risks associated with the introduction of a bio fuel blend and the suitability of the appliances and installation applicable.

Irrespective of any warranty given by Riello in relation to normal use and manufacturing defects, when fuels not meeting the relevant standards are used, or where fuel storage issues have not been addressed correctly, or the equipment used is not compatible, if failures occur which are directly or indirectly attributed to such issues and/or to the non-observance of this guidance, then no warranty or liability is implied or accepted by Riello.

1.3.1 Information and general instructions

To ensure consistency, the supplier of the fuel must be able to demonstrate compliance with a recognised Quality Control and management system to ensure high standards are maintained within the storage, blending and delivery processes.

The installation oil storage tank and its ancillaries must also be prepared BEFORE liquid Bio fuel is introduced.

Checks and preparation should include:

- For new installations, make sure that all materials and seals in the oil storage and supply line to the burner are compatible with Bio fuels. For all installations, there must be a good quality bio compatible oil filter at the tank and then a secondary filter of 60 Microns protecting the burner from contamination.
- If an existing oil storage tank is to be used then in addition to the materials checks as detailed above, it will be essential that the tank is first inspected for condition and checked for water or other contamination. Riello strongly recommends that the tank is cleaned and oil filters replaced prior to Bio fuel delivery. If this is not completed then due to the hygroscopic nature of Bio fuel, it will effectively clean the tank,

absorb water present which in turn will result in equipment failure that is not covered by the manufacturer's warranty.

- Depending on the capacity of the oil storage tank and oil usage, fuels may remain static within the tank for some considerable time and so Riello recommends that the oil distributor is consulted regarding the use of additional Biocides within the fuel to prevent microbial growth from occurring within the tank. Riello suggests that fuel suppliers and or service companies are contacted for guidance on fuel filtration. Special attention should be applied to dual fuel applications where oil may be stored for long periods of time.
- The burner must be set according to the appliance application and commissioned checking that all combustion parameters are as recommended in the appliance technical manual.
- Riello recommends that the in line and burner oil pump filters are inspected and if required replaced at least every 4 months during burner use, before the burner start-up following a long period of discontinuous operation and even more frequently where contamination has occurred. Particular attention is needed when inspecting and checking for fuel leakages from seals, gaskets and hoses.

1.3.2 Product Disclaimer Statement

CAREFULLY READ THE FOLLOWING DISCLAIMER. YOU ACCEPT AND AGREE TO BE BOUND BY THIS DISCLAIMER BY PURCHASING RIELLO BIO COMPATIBLE BURNERS AND/OR COMPONENTS.

Although the information and recommendations (hereinafter "Information") in this guidance is presented in good faith, believed to be correct and has been carefully checked, Riello (and its subsidiaries) makes no representations or warranties as to the completeness or accuracy of the Information. Information is supplied upon the condition that the persons receiving same will make their own determination as to its suitability for their purposes prior to use. In no event will Riello (and its subsidiaries) be responsible for damages of any nature whatsoever resulting from the use of or reliance upon Information.

Other than set forth herein, Riello (and its subsidiaries) makes no additional warranties with respect to the bio compatible burner, either express or implied, including that of merchantability or fitness for a particular purpose or use.

In no event shall Riello (and its subsidiaries) be liable for any indirect, incidental, special or consequential damages including, without limitation, loss of profits, damages for loss of business profits, business interruption, loss of business information, loss of equipment, or other pecuniary loss or compensation for services whether or not it is advised of the possibility of such damages.

With the exception of injuries to persons, Riello's liability is limited to the customer's right to return defective/non-conforming products as provided by the relevant product warranty.

2 Safety and prevention

2.1 Introduction

The burners have been designed and built in compliance with current regulations and directives, applying the known technical rules of safety and envisaging all the potential danger situations. It is necessary, however, to bear in mind that the imprudent and clumsy use of the equipment may lead to situations of death risk for the user or third parties, as well as the damaging of the burner or other items. Inattention, thoughtlessness and excessive confidence often cause accidents; the same applies to tiredness and sleepiness.

It is a good idea to remember the following:

- The burner must only be used as expressly described. Any other use should be considered improper and therefore dangerous.

In particular:

it can be applied to boilers operating with water, steam, diathermic oil, and to other uses expressly named by the manufacturer;

the type and pressure of the fuel, the voltage and frequency of the electrical power supply, the minimum and maximum deliveries for which the burner has been regulated, the pressurisation of the combustion chamber, the dimensions of the combustion chamber and the room temperature must all be within the values indicated in the instruction manual.

- Modification of the burner to alter its performance and destinations is not allowed.
- The burner must be used in exemplary technical safety conditions. Any disturbances that could compromise safety must be quickly eliminated.
- Opening or tampering with the burner components is not allowed, apart from the parts requiring maintenance.
- only those parts detailed as available as spare parts by the manufacturer can be replaced.

2.2 Safety warnings

The dimension of the boiler's combustion chamber must respond to specific values, in order to guarantee a combustion with the lowest polluting emissions rate.

The Technical Service Personnel will be glad to give you all the information for a correct matching of this burner to the boiler.

This burner must only be used for the application it was designed for.

The manufacturer accepts no liability within or without the contract for any damage caused to people, animals and property due to installation, adjustment and maintenance errors or to improper use.

2.3 Basic safety rules

- Children or inexperienced persons must not use the appliance.
- Under no circumstances must the intake grids, dissipation grids and ventilation vents in the installation room be covered up with cloths, paper or any other material.
- Unauthorised persons must not attempt to repair the appliance.
- It is dangerous to pull or twist the electric leads.
- Cleaning operations must not be performed if the appliance is not disconnected from the main power supply.
- Do not clean the burner or its parts with inflammable substances (e.g. petrol, alcohol, etc.). The cover must be cleaned with soapy water.
- Do not place anything on the burner.
- Do not block or reduce the size of the ventilation vents in the installation room.
- Do not leave containers and inflammable products or combustible materials in the installation room.

2.4 Personnel training

The user is the person, body or company that has acquired the machine and intends to use it for the specific purpose. He is responsible for the machine and for the training of the people working around it.

The user:

- undertakes to entrust the machine exclusively to suitably trained and qualified personnel;
- must take all the measures necessary to prevent unauthorised people gaining access to the machine;
- undertakes to inform his personnel in a suitable way about the application and observance of the safety instructions. With that aim, he undertakes to ensure that everyone knows the use and safety instructions for his own duties;
- must inform the manufacturer if faults or malfunctioning of the accident prevention systems are noticed, along with any presumed danger situation.
- Personnel must always use the personal protective equipment envisaged by legislation and follow the indications given in this manual.
- Personnel must observe all the danger and caution indications shown on the machine.
- Personnel must not carry out, on their own initiative, operations or interventions that are not within their province.
- Personnel must inform their superiors of every problem or dangerous situation that may arise.
- The assembly of parts of other makes, or any modifications, can alter the characteristics of the machine and hence compromise operating safety. The manufacturer therefore declines any and every responsibility for any damage that may be caused by the use of non-original parts.

3 Technical description of the burner

3.1 Technical data

Code	3516010	3516020	20015255
Output - Thermal power (with air at 20 °C)	1.0 – 1.5 kg/h 12 – 18 kW	1.5 – 2.1 V 18 – 25 kW	2.1 – 2.7 kg/h 25 – 32 kW
Fuel	Kerosene, viscosity 1.6 – 6 mm ² /s at 20 °C (Hi = 11.97 kWh/kg)		
Electrical supply	Single phase, ~ 50Hz 230V ± 10%		
Motor	Run current 0.7A – 2700 rpm – 283 rad/s		
Capacitor	4.5 µF		
Ignition transformer	Secondary 18 kV – 25 mA		
Pump	Kerosene, maximum pressure 10 bar (145 psi)		
Absorbed electrical power	0.115 kW	0.16 kW	

Tab. A

3.2 Burner description

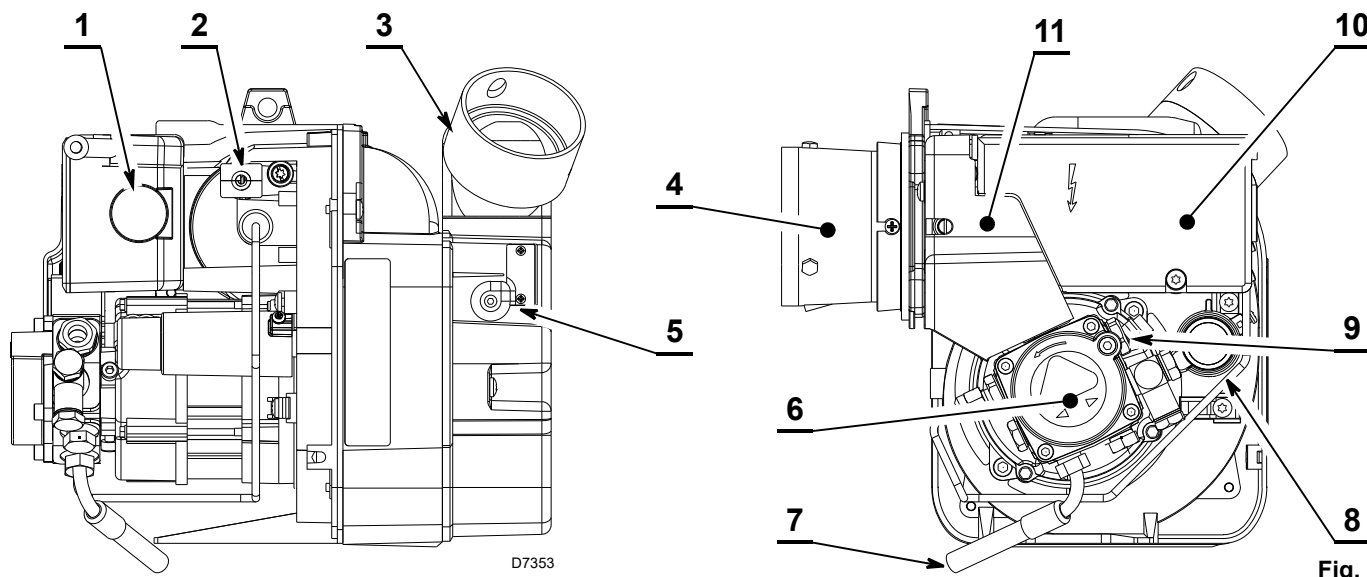

- 1 Reset push-button with lock-out lamp
- 2 Flame sensor
- 3 Snorkel
- 4 Blast tube
- 5 Air damper adjustment screw
- 6 Pump

- 7 Hose
- 8 Capacitor
- 9 Pump pressure adjustment screw
- 10 Control box
- 11 Coil protection

3.3 Burner equipment

Screw of by-pass pump..... No. 1



The hoses supplied with this burner set for Kerosene use are not suitable for use with Gas oil containing a Bio blend.

Please refer to the spare part list for the specific hoses suitable for bio fuel use.

In case of use with gas oil containing up to 10% Bio blend, it will be essential to use flexible oil lines suitable for bio fuel use.

Please contact Riello for further information.

3.4 Burner dimensions

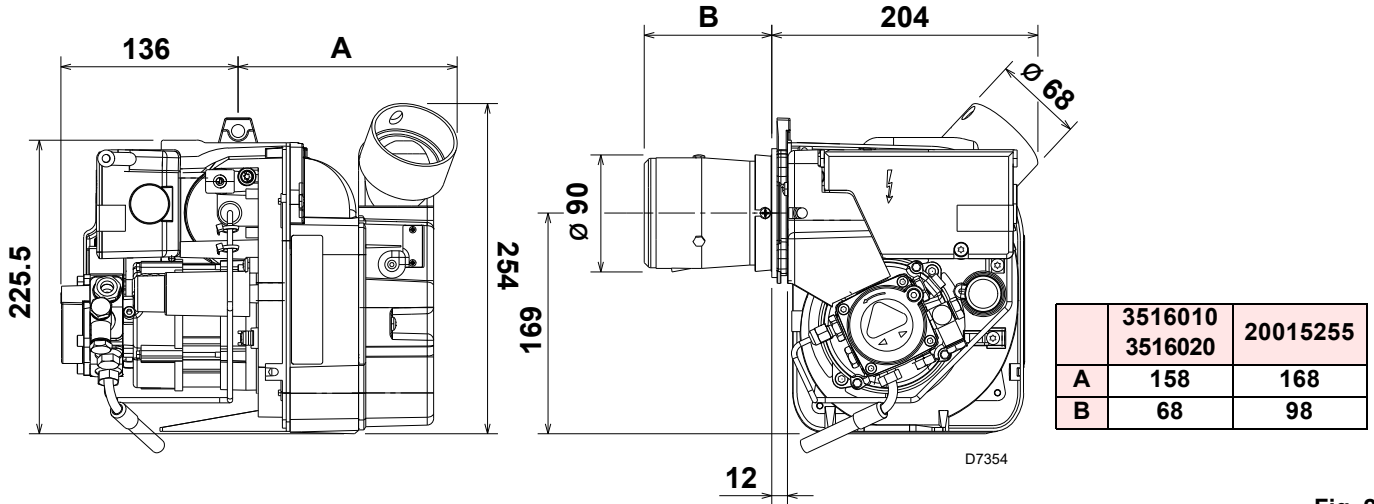

Fig. 2

3.5 Firing rates

The **MAXIMUM OUTPUT** is chosen from within the diagram area (Fig. 3).

The **MINIMUM OUTPUT** must not be lower than the minimum limit of the diagram.

The burner delivery must be selected within area of the diagrams (Fig. 3). This area is called firing rates and provides the maximum delivery of the burner in relation to the pressure in the combustion chamber.

The work point may be found by plotting a vertical line from the desired delivery and a horizontal line from the pressure in the combustion chamber. The intersection of these two lines is the work point which must lie within the firing rates.



The firing rate area values have been obtained considering a surrounding temperature of 20 °C, and an atmospheric pressure of 1013 mbar (approx. 0 m above sea level) and with the combustion head adjusted as shown on page 18.

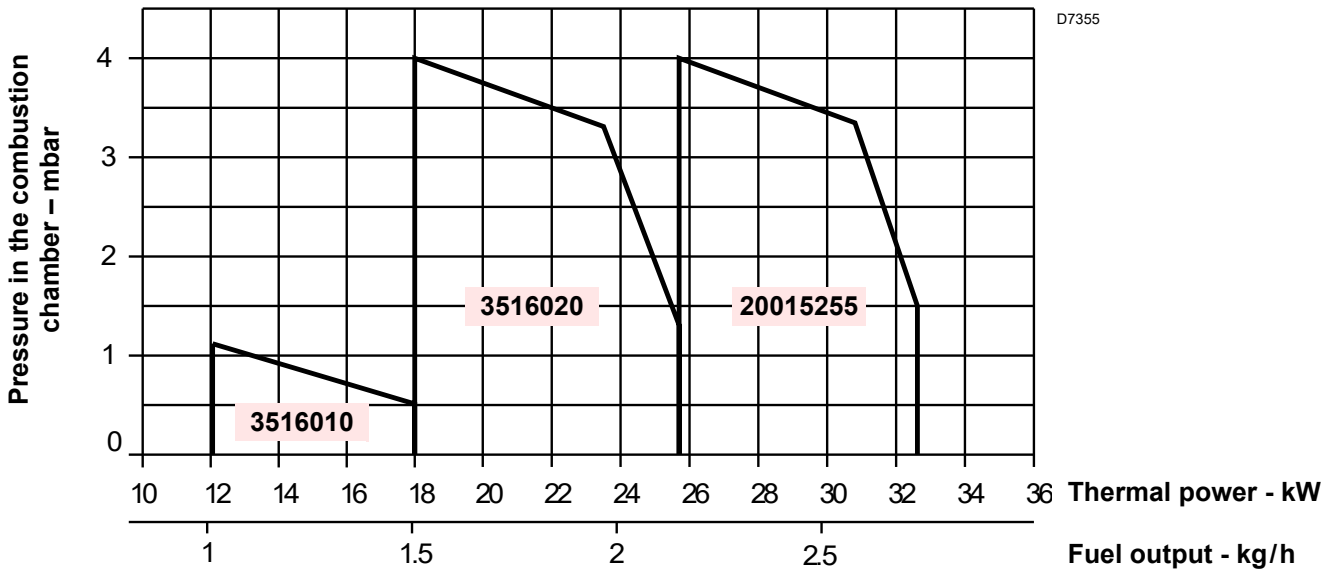

Fig. 3

4 Installation

4.1 Notes on safety for the installation

After carefully cleaning all around the area where the burner will be installed, and arranging the correct lighting of the environment, proceed with the installation operations.



All the installation, maintenance and disassembly operations must be carried out with the electricity supply disconnected.



The installation of the burner must be carried out by qualified personnel, as indicated in this manual and in compliance with the standards and regulations of the laws in force.

4.2 Handling

The packaging of the burner includes a carton box, so it is possible to move the burner (still packaged) with a transpallet truck or fork lift truck.



The handling operations for the burner can be highly dangerous if not carried out with the greatest attention: keep any unauthorised people at a distance; check the integrity and suitability of the available means of handling. Check also that the area in which you are working is empty and that there is an adequate escape area (i.e. a free, safe area to which you can quickly move if the burner should fall). When handling, keep the load at not more than 20-25cm from the ground.



After positioning the burner near the installation point, correctly dispose of all residual packaging, separating the various types of material.



Before proceeding with the installation operations, carefully clean all around the area where the burner will be installed.

4.3 Preliminary checks

Checking the consignment



After removing all the packaging, check the integrity of the contents. In the event of doubt, do not use the burner; contact the supplier.



The packaging elements (wooden cage or cardboard box, nails, clips, plastic bags, etc.) must not be abandoned as they are potential sources of danger and pollution; they should be collected and disposed of in the appropriate places.

Checking the characteristics of the burner

Check the identification label of the burner, showing:

- the model **A**(Fig. 4) and type of burner **B**;
- the year of manufacture, in cryptographic form **C**;
- the serial number **D**;
- the electrical input power **E**;
- the types of fuel used and the relative supply pressures **F**;
- the data of the burner's minimum and maximum output possibilities **G** (see Firing rate).

R.B.L.	A		B	
	D	C	$\text{D} \leq$	G
	B	E		
F				
RIELLO S.p.A. I-37045 Legnago (VR)				xxxx

D9370

Fig. 4



The output of the burner must be within the boiler's firing rate.



A burner label that has been tampered with, removed or is missing, along with anything else that prevents the definite identification of the burner makes any installation or maintenance work difficult.

4.4 Installer/Service notes for the use of Gas oil with Bio blends up to 10% where gas oil use is permitted by the appliance Manufacturer

- During the burner installation, check that the gasoil and bio fuel blends are in accordance with Riello specifications (please refer to the chapters "Technical Data" and "Guidance for the use of bio fuel blends up to 10%" within the burner technical manual).
- If a Bio blend is in use the installer must seek information from the end user that their fuel supplier can evidence that the blends of fuel conform to the relevant standards.
- Check that the materials used in the construction of the oil tank and ancillary equipment are suitable for bio fuels, If not these must be upgraded or replaced with Bio compatible parts.
- Particular attention should be given to the oil storage tank and supply to the burner. Riello recommends that existing oil storage tanks are cleaned, inspected and any traces of water are removed BEFORE bio fuel is introduced (Contact the tank manufacturer or oil supplier for further advice). If these recommendations are not respected this will increase the risk of contamination and possible equipment failure.
- In line oil filters should be replaced making sure that they are Bio compatible. Riello recommends a good quality bio compatible oil filter at the tank and a secondary 60 micron filter are used to protect the burner pump and nozzle from contamination.
- The burner hydraulic components and flexible oil lines must be suitable for bio fuel use (check with Riello if in doubt). Riello have carefully chosen the specification of the bio compatible components including the flexible oil lines to protect the pump, safety valve and nozzle. The Riello warranty is dependent upon the use of Riello genuine components including the oil lines, being used. The burner must be commissioned and combustion parameters set to appliance manufacturer's recommendations.
- Regularly check visually for any signs of oil leakage from seals, gaskets and hoses.
- It is strongly recommended that with Bio fuel use, oil filters are inspected and replaced every 4 months. More regularly where contamination is experienced.
- During extended periods of non operation and/or where burners are using oil as a standby fuel, it is strongly recommended that the burner is put into operation for short periods at least every three months.

4.5 Working position



- The burner is designed to operate only in the positions **1**, and **3** (Fig. 5).
- Installation **1** is preferable, as it is the only one that allows performing maintenance operations as described in this manual.
- Installations **2**, **3** and **4** allow working operations but not maintenance with hooking to the boiler.



- Any other position could compromise the correct operation of the appliance.
- Installation **5** is forbidden for safety reasons.

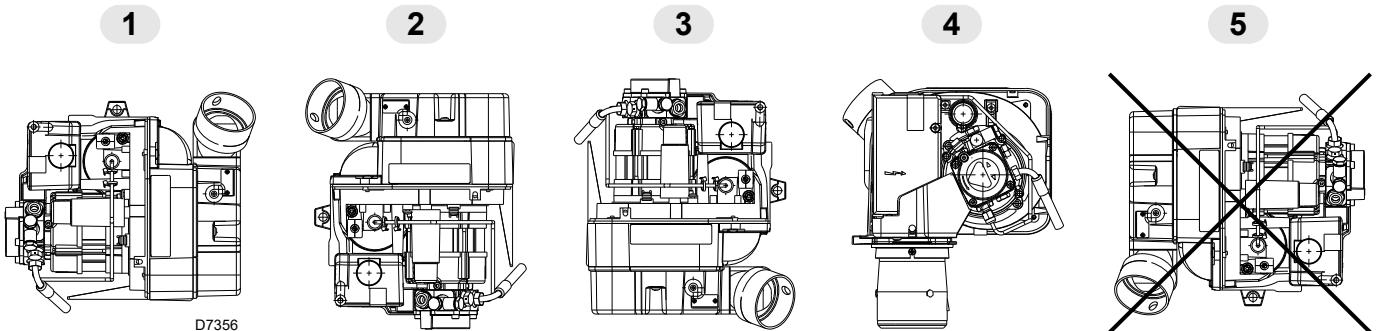

Fig. 5

4.6 Boiler fixing



Prepare a suitable lifting system.

- Align burner combustion head 1)(Fig. 7) interposing the insulating gasket 2), into the boiler housing tube 3)(Fig. 6).
- Push firmly down to compress the gasket 2).
- Tighten the two screw 4) sufficiently to ensure a good seal.
- Make sure any electrical cable and flexible oil line are routed away from hot surfaces.



WARNING

The seal between burner and boiler must be air-tight.

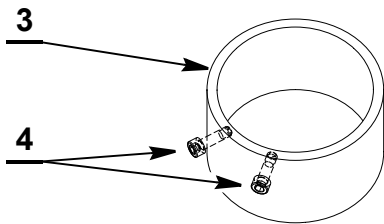

D7419

Fig. 6

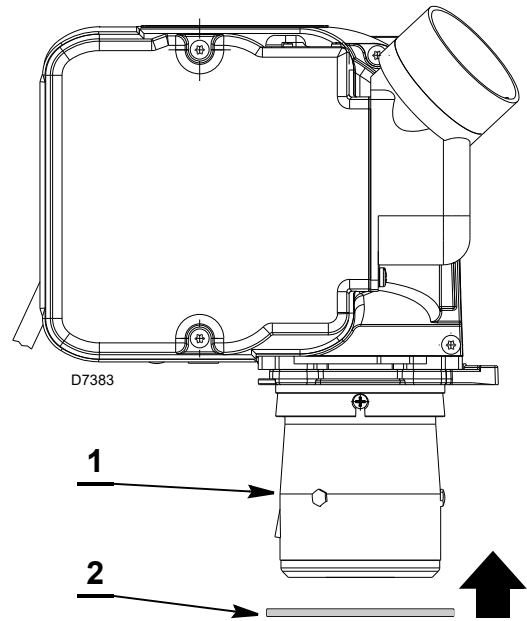

D7383

Fig. 7

4.7 Burner assembly



CAUTION

The temperature of the incoming air must not exceed 70 °C.

The combustion air supply is through a flexible or rigid pipe connected to the air intake.

Consequently, you must comply with the following requirements and instructions:

- The combustion air intake tube must be:
 - fastened securely to the burner;
 - made of a suitable material, with temperature characteristics in the range - 30 °C to 80 °C;
 - in compliance with all requirements of applicable regulations in force in the country of destination.
- The intake-tube / burner system must not allow a loss of over 2 m³/h at 0.5 mbar:

for instance, the above requirements will be met if you use flues for pressure exhaust of flue gases (the condensation kind).

- Make sure the air intake tube's inlet is positioned so that it is not likely to be obstructed by foreign matter and, where necessary, use suitable screens.
- The inside diameter of the hose must be at least 80 mm.
- The intake tube can be up to 6 metres in length.



WARNING

Length is reduced if there are bends in the intake section.

For instance, using a tube with a smooth inside surface, you must allow for the following losses:

- for each 45° bend, tube length is reduced by 0.5 m;
- for each 90° bend, tube length is reduced by 0.8 m.

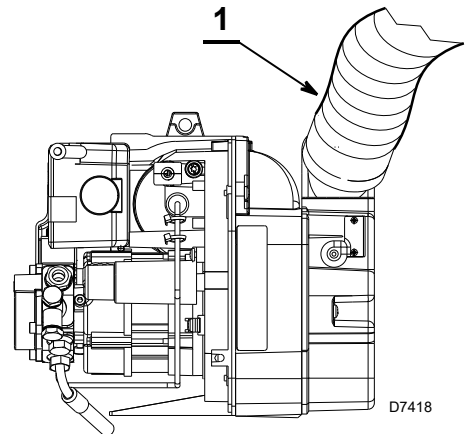

D7418

Fig. 8

NOTE:

Burner installation must in any case comply with the flue systems included within the boiler approved configuration.



WARNING

- Under no circumstances should the air's entry in the hose intake area be obstructed.
- The hose must not be blocked in any way or feature a shutting device (valves, membranes etc.).

5 Hydraulic systems

5.1 Fuel supply



Explosion danger due to fuel leaks in the presence of a flammable source.

Precautions: avoid knocking, attrition, sparks and heat.

Make sure the fuel interception tap is closed before performing any operation on the burner.



WARNING

The fuel supply line must be installed by qualified personnel, in compliance with current standards and laws.

5.1.1 Pump

The pump is designed to allow working with one pipe.

In order to obtain two pipes working it is necessary to unscrew the return plug 2)(Fig. 9), screw the by-pass screw 3),supplied as burner equipment and then screw the return hose.

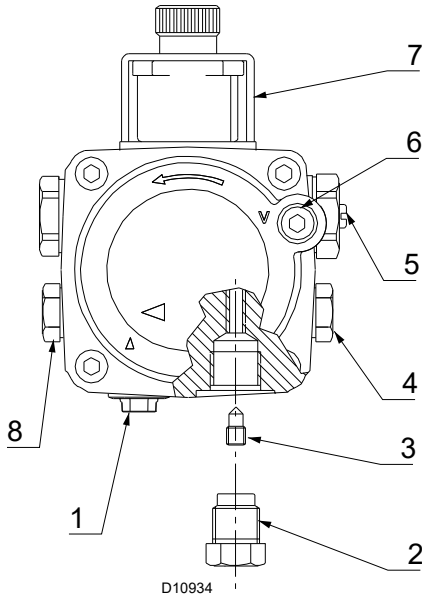

Fig. 9

Key (Fig. 9)

- | | |
|--------------------|---------------------------------|
| 1 Suction line | 5 Pressure adjuster |
| 2 Return line | 6 Vacuum gauge connection |
| 3 By-pass screw | 7 Valve |
| 4 Gauge connection | 8 Auxiliary pressure test point |



WARNING

Where gas oil containing bio diesel is in use, it is recommended to avoid over oxygenation of the blended fuels.

Where at all possible avoid the use of two pipe systems where the circulated fuel is returned to the tank.

If this cannot be avoided make sure that the return pipe is normally below the surface of the fuel level within the storage tank. See Fig. 12.



WARNING

The suction plug 1) is made of plastic. Once removed, it must not be used again.

In single pipe installations, the plug in the return line 2) must be totally in steel.



WARNING

In case of use with gas oil containing up to 10% Bio blend, it will be essential to use flexible oil lines suitable for bio fuel use.

Please contact Riello for further information.

5.2 One pipe system

Pressurised one pipe systems (Fig. 10) have a positive fuel pressure on intake to the burner.

Usually the tank is higher than the burner, or the fuel pumping systems are on the outside of the boiler.

Vacuum one pipe systems (Fig. 11) have a negative fuel pressure (depression) on intake to the burner.

Usually the tank is lower than the burner.



You are advised to use additional filters on the fuel supply line.

Riello recommends a good quality fuel filter at the tank (Fig. 10 - Fig. 11) and a secondary filter (60 μ for gas oil and 15 μ for kerosene) are used to protect the burner pump and nozzle from contamination.

In case of Biodiesel use, pay attention to install Biocompatible filters.

5.2.1 Priming pump

On the system in Fig. 10 it is sufficient to loosen the plug of the vacuum gauge 6)(Fig. 9) and wait until the fuel flows out.

On the system in Fig. 11 start the burner and wait for the priming. Should lock-out occur prior to the arrival of the fuel, await at least 20 seconds before repeating the operation.



The installer must ensure that the supply pressure is not above 0.5 bar.

Above that level, the pump seal is subject to too much stress.

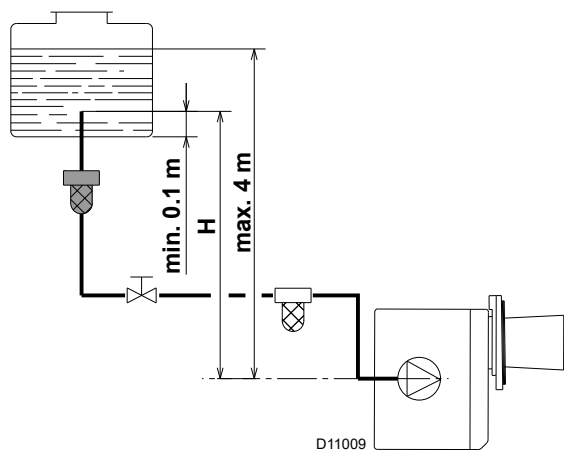

Fig. 10

H metres	L metres	
	I.D. (8 mm)	I.D. (10 mm)
0.5	10	20
1	20	40
1.5	40	80
2	60	100

Tab. B

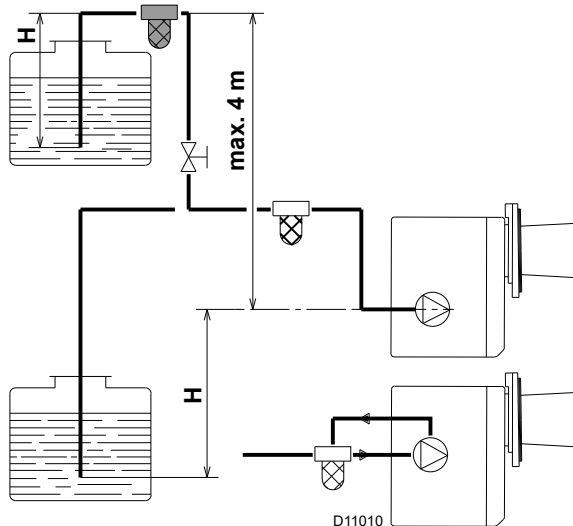

Fig. 11

H metres	L metres	
	I.D. (8 mm)	I.D. (10 mm)
0	35	100
0.5	30	100
1	25	100
1.5	20	90
2	15	70
3	8	30
3.5	6	20

Tab. C

- H** difference of level
- L** max. length of the suction line
- I.D.** internal diameter of the oil pipes

NOTE:

The Tab. B and Tab. C show the maximum approximate lengths for the supply line, depending on the difference in level, length, and the diameter of the fuel conduit.

5.3 Two pipe system

Vacuum two pipe systems (Fig. 12) have a negative fuel pressure (depression) on intake to the burner.

Usually the tank is lower than the burner.

The return line should terminate in the oil tank at the same level as the suction line; in this case a non-return valve is not required.

Should however the return line arrives over the fuel level, the non-return valve is indispensable. This solution however is less safe than previous one, due to the possibility of leakage of the valve.



You are advised to use additional filters on the fuel supply line.

Riello recommends a good quality fuel filter at the tank (Fig. 12) and a secondary filter (60 μ for gas oil and 15 μ for kerosene) are used to protect the burner pump and nozzle from contamination.

In case of Biodiesel use, pay attention to install Biocompatible filters.

5.3.1 Priming pump



Before starting the burner make sure that the return pipe-line is not clogged: any obstruction would cause the pump seals to break.

On the system in Fig. 12 start the burner and wait for the priming. Should lock-out occur prior to the arrival of the fuel, await at least 20 seconds before repeating the operation.



The pump vacuum should not exceed a maximum of 0.4 bar (30 cm Hg). Beyond this limit gas is released from the oil.

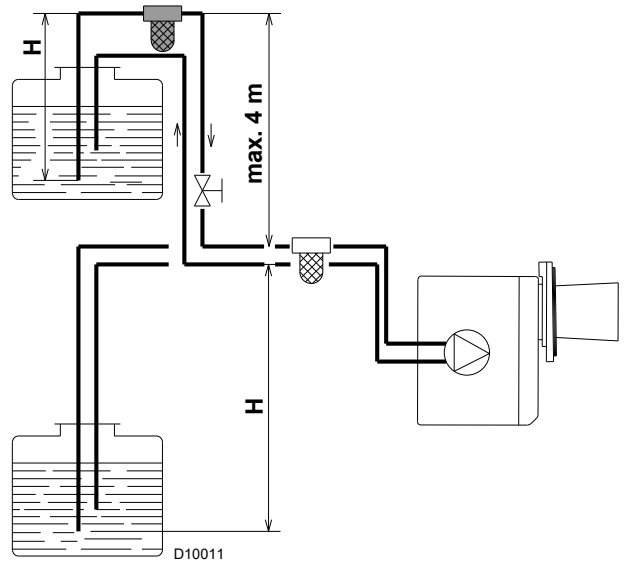

Fig. 12

H metres	L metres	
	I.D. (8 mm)	I.D. (10 mm)
0	35	100
0.5	30	100
1	25	100
1.5	20	90
2	15	70
3	8	30
3.5	6	20

Tab. D

H difference of level

L max. length of the suction line

I.D. internal diameter of the oil pipes

NOTE:

The Tab. D shows the maximum approximate lengths for the supply line, depending on the difference in level, length, and the diameter of the fuel conduit.

6 Electrical system

6.1 Notes on safety for the electrical wiring



DANGER

- The electrical wiring must be carried out with the electrical supply disconnected.
- Electrical wiring must be carried out by qualified personnel and in compliance with the regulations currently in force in the country of destination. Refer to the wiring diagrams.
- The manufacturer declines all responsibility for modifications or connections different from those shown in the wiring diagrams.
- Do not invert the neutral with the phase in the electrical supply line.
- Check that the electrical supply of the burner corresponds to that shown on the identification label and in this manual.
- The burners have been set for intermittent operation. This means they should compulsorily be stopped at least once every 24 hours to enable the control box to perform checks of its own start-up efficiency. Normally the boiler's thermostat/pressure switch ensures the stopping of the burner.
If this is not the case, it is necessary to apply in series with L-N a timer switch that turns off the burner at least once every twenty-four hours. Refer to the wiring diagrams.
- The electrical safety of the device is obtained only when it is correctly connected to an efficient earthing system, made according to current standards. It is necessary to check this fundamental safety requirement. In the event of doubt, have the electrical system checked by qualified personnel.
- The electrical system must be suitable for the maximum input power of the device, as indicated in the manual, checking in particular that the section of the cables is suitable for the input power of the device.
- For the main power supply of the device from the electricity mains:
 - do not use adapters, multiple sockets or extensions;
 - use an omnipolar switch, as indicated by the current safety standards.
- Do not touch the device with wet or damp body parts and/or in bare feet.
- Do not pull the electric cables.

Before carrying out any maintenance, cleaning or checking operations:



DANGER

Disconnect the electrical supply from the burner by means of the main system switch.



DANGER

Turn off the fuel interception tap.



DANGER

Avoid condensate, ice and water leaks from forming.

If the cover is still present, remove it and proceed with the electrical wiring according to the wiring diagrams.

Use flexible cables in compliance with the EN 60 335-1 standard.

6.1.1 Control box



DANGER

This operation must be performed with the burner turned off and mains power disconnected.

To remove the control box (Fig. 13) from the burner follow of the instruction:

- Loosen the screw 1) and remove protection 6) of the electrical connections and coil.
- Loosen the screws 2), open the protection 3) and remove all components.
- Remove the coil 4) and loosen the two screws 5).
- Move a little the control box and remove the high voltage leads.

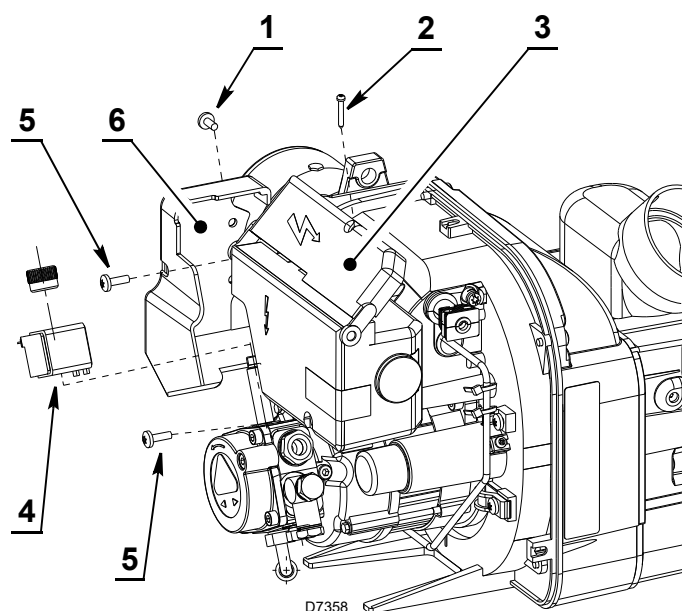

D7358

Fig. 13



The control box can be used on burners with or without a heater.

If the heater is damaged, insert the jumper 7) (Fig. 14) in the control box so that the burner can work without the heater until the latter is replaced.

NOTE:

The control box is supplied with the jumper 7)(Fig. 14) already installed.

If the control box is installed on a burner with heater, it is necessary to remove the jumper 7) before replacing the cover.

Connect the heater cables and thermostat as well.



Fig. 14

6.1.2 Motor capacitor

The proper positioning of motor capacitor cover is shown in the detail of Fig. 15.

To remove the motor capacitor cover from the burner, loosen the screw 1).

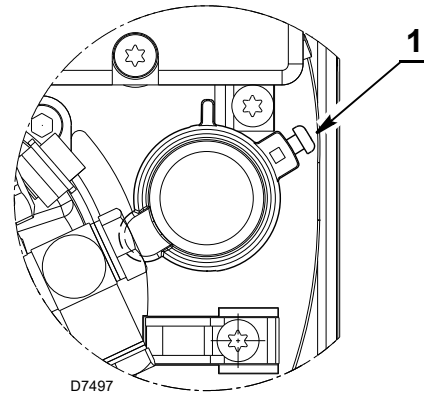

Fig. 15

6.2 Electrical wiring

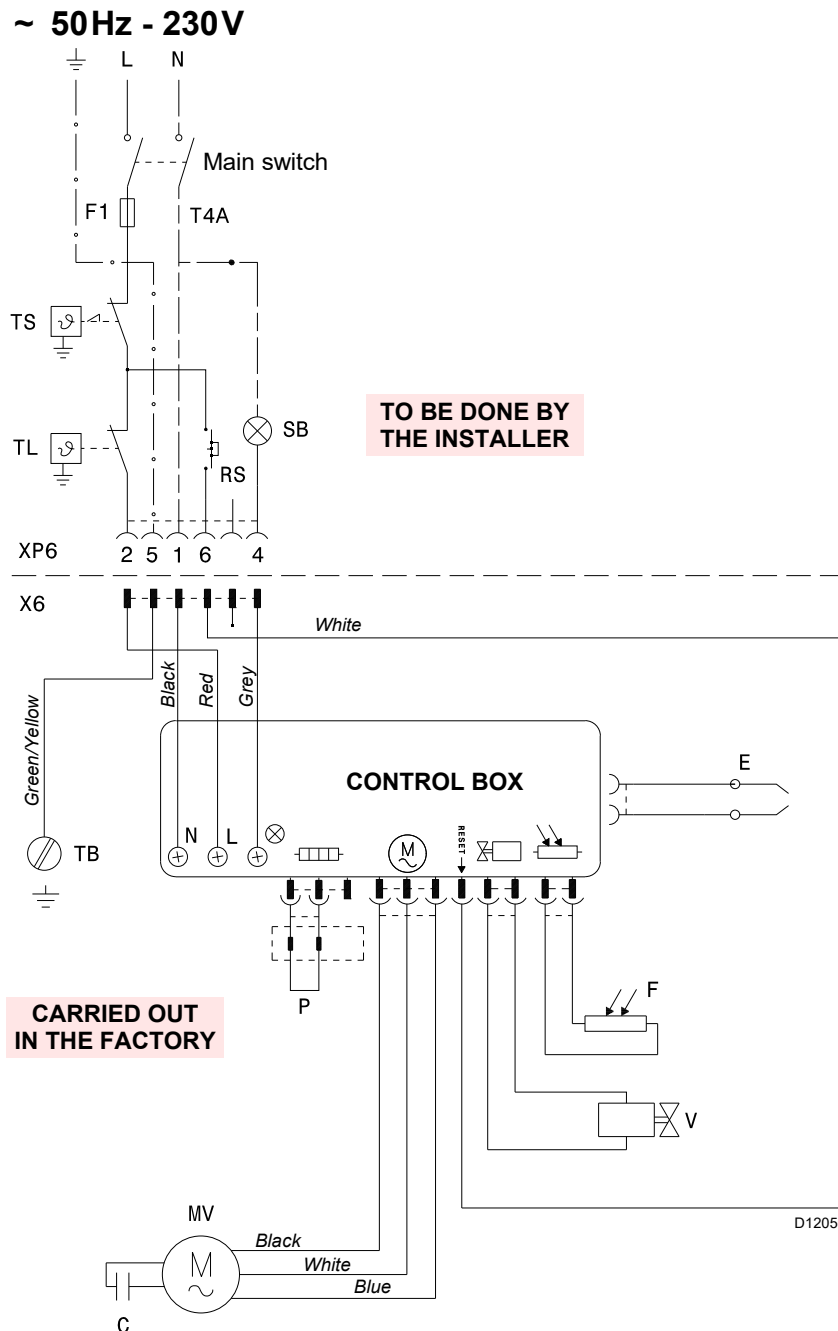

Fig. 16



WARNING

- Do not invert the neutral with the phase in the electrical supply line.
- Check that the electrical supply of the burner corresponds to that shown on the identification label and in this manual.
- The section of the conductors must be at least 1mm². (Unless otherwise required by local guidelines and laws).



WARNING

Test the burner by checking the shutdown of the burner by opening the thermostats and the lockout by darkening the flame sensor.



CAUTION

- If the hood is still present, remove it and proceed with the electrical wiring according to the wiring diagrams.
- Use flexible cables in compliance with the EN 60 335-1 standard.

Key to lay-out (Fig. 16)

C	Capacitor
E	Ignition electrodes
F	Flame sensor
MV	Motor
P	Short circuit socket
RS	Remote reset
SB	External signal lock-out (230V - 0.5A max)
TB	Burner-earth
TL	Thermostat of heat demand
TS	Safety thermostat
V	Oil valve
XP6	6 pole socket
X6	6 pin plug

7 Start-up, calibration and operation of the burner

7.1 Notes on safety for the first start-up



The first start-up of the burner must be carried out by qualified personnel, as indicated in this manual and in compliance with the standards and regulations of the laws in force.



Check the correct working of the adjustment, command and safety devices.

7.2 Combustion adjustment

In conformity with EN 267, the application of the burner on the boiler, adjustment and testing must be carried out observing the instruction manual of the boiler, including verification of the CO and CO₂ concentration in the flue gases, their temperatures and the average temperature of the water in the boiler.



The combustion air is sucked from outside, therefore, there can be sensitive temperature variations that can influence the percentage value of the CO₂. It is advisable to adjust the CO₂ according to the diagram.

For example: with an combustion air temperature of 20°C, adjust the CO₂ to 12.5% (± 0.2%).

The values are refer to 12.5% CO₂, at sea level and with ambient temperature and light oil at 20 ° C.

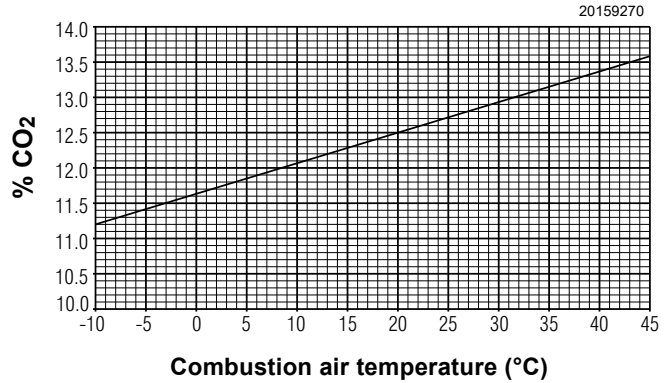

Fig. 17

7.3 Nozzles installation

The burner complies with the emission requirements of the EN 267 standard.

In order to guarantee that emissions do not vary, recommended and/or alternative nozzles specified by the manufacturer in the instruction and warning booklet should be used.



It is advisable to replace nozzles every year during regular maintenance operations.



The use of nozzles other than those specified by the manufacturer and inadequate regular maintenance may result into emission limits non-conforming to the values set forth by the regulations in force, and in extremely serious cases, into potential hazards to people and objects.

The manufacturing company shall not be liable for any such damage arising from nonobservance of the requirements contained in this manual.

7.3.1 Nozzles recommended

According to the application.

7.4 Pump pressure

The pump leaves the factory set for kerosene working.

10 bar: maximum pressure for kerosene.

7.5 Electrodes setting



The position of the electrodes cannot be regulated. In case of failure, check that the measurements as shown on the figure are respected.

Before removing or assembling the nozzle, loosen the screw (A, Fig. 18) and move the electrodes ahead.

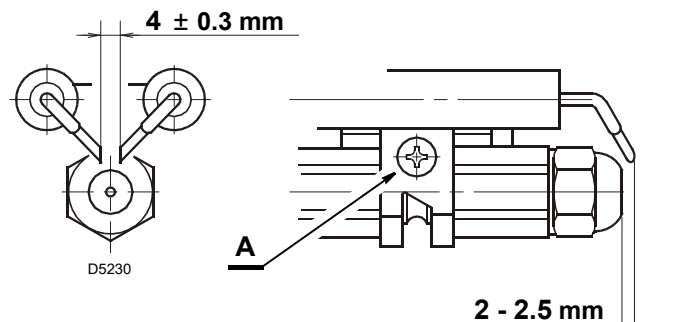

Fig. 18

7.6 Air damper adjustment

The air damper is set in factory. This regulation is purely indicative.

Each installation however, has its own unpredictable working conditions: actual nozzle output; positive or negative pressure in the combustion-chamber, the need of excess air, etc.

All these conditions may require a different air damper setting.



Only for code 3516010 - 3516020

The air setting is performed by mean of two independent dampers (see Fig. 19 and Fig. 20).

7.6.1 Main air damper

The main air damper can be set in either of two positions.

To set the positions of the damper, proceed as follows:

- remove the secondary air damper B)(Fig. 19) loosing the screws 1).
- Loosen the screw 2) and rotate the main air damper A) to the required position.
- Retighten the screw 2) and put back the secondary air damper B).

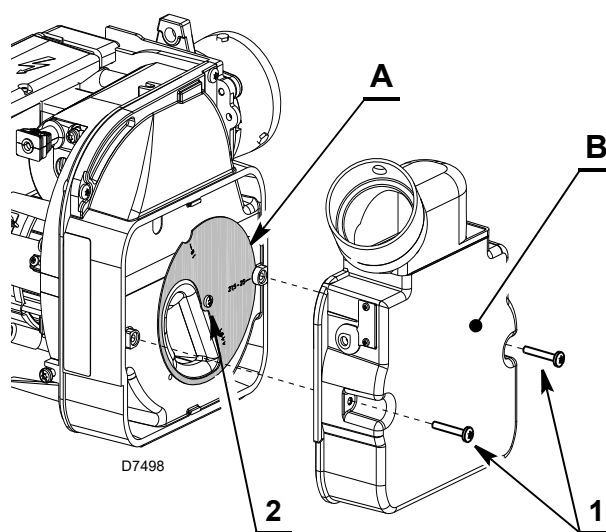

Fig. 19

7.6.2 Secondary air damper

The purpose of this damper is to perform a fine-tuning of the inlet air.

Tuning of this device is possible acting of the screw 3)(Fig. 20).

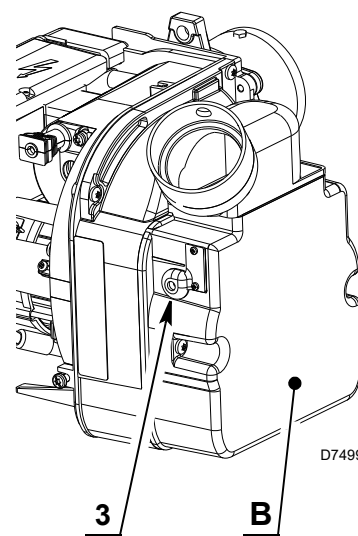

Fig. 20

7.7 Operation programme

Normal operation

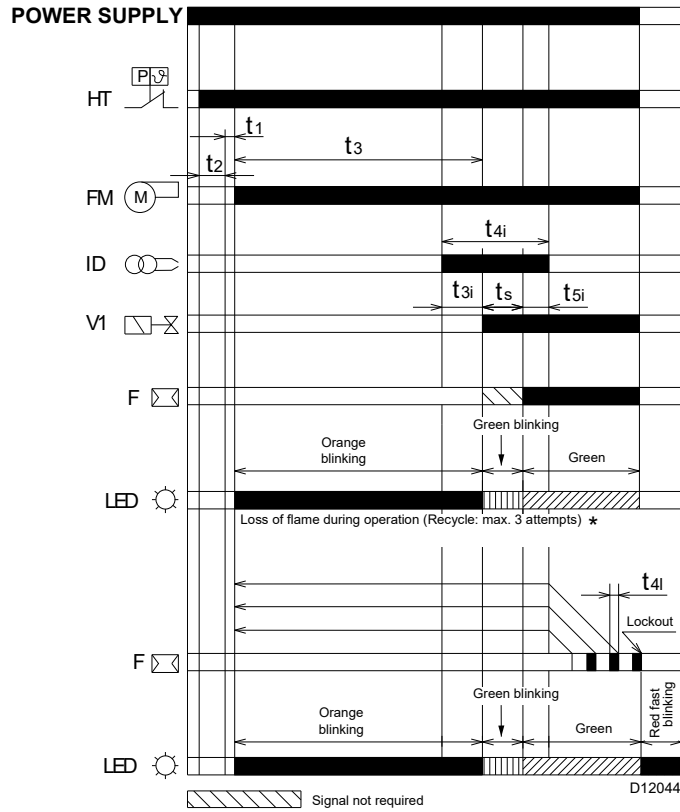

Fig. 21

Lockout due to ignition failure

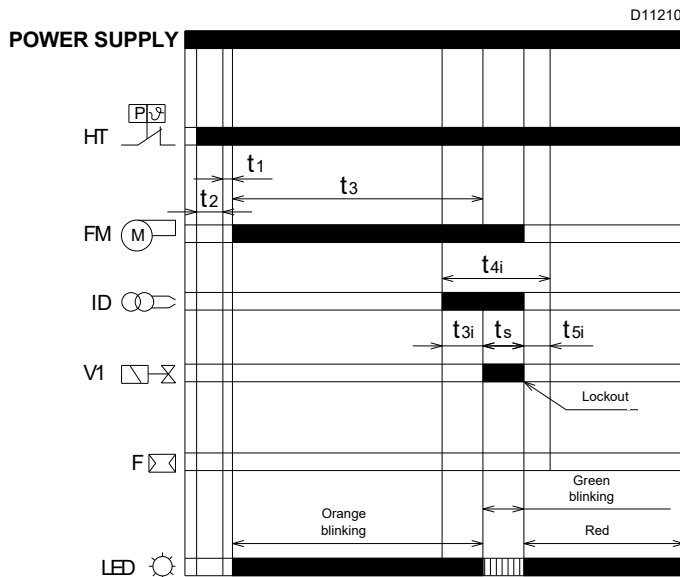

Fig. 22

Lockout due to extraneous light during pre-purging

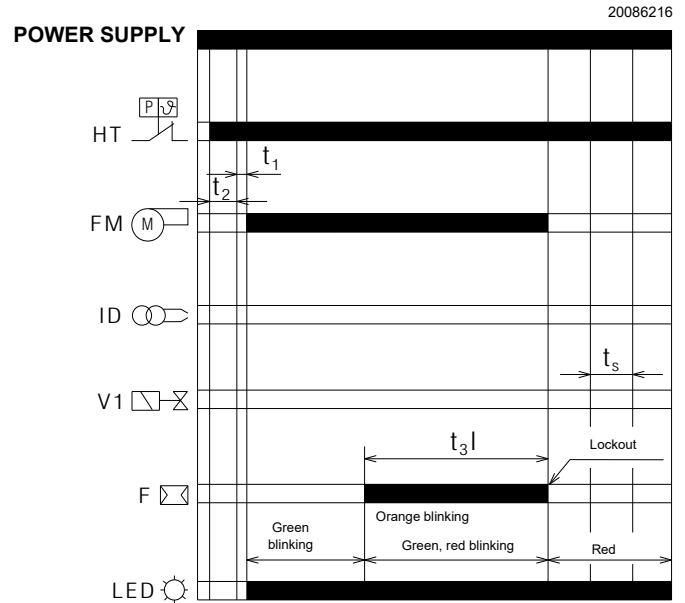

Fig. 23

Key (Fig. 21 - Fig. 22 - Fig. 23)

- F Flame sensor
- HT Heat request thermostat (TL)
- ID Ignition device
- MV Fan motor
- SB Remote lockout signal
- V1 Oil valve
- LED Reset push-button LED colour
- ts Safety time
- t1 Standby time
- t2 Initialisation check time
- t3 Pre-purge time
- t3i Pre-ignition time
- t3l Checks extraneous light during pre-purging
- t4i Total spark ignition time
- t4l Reaction time to achieve safety shutdown due to flame failure
- t5i Post-ignition time
- * Only 3 consecutive re-ignition attempts are permitted

7.8 Table of timings

Symbol	Description	Value (sec.)
t0	Standby: the burner is waiting for a heat request	-
t1	Standby time for an input signal: reaction time, control box remains in waiting status for t1	≤ 1
t2	Initialisation standby time: check time following the main power start-up	3.5
t2l	Checks extraneous light during t2: waiting mode for t2l, then lockout: the motor does not start	25
t2p	Oil pre-heating time : waiting mode for t2p, then there is a lockout (if there is a heater)	max 600*
t3	Pre-purge time: the fan motor is working	15
t3l	Checks extraneous light during pre-purging: control box goes into lockout at the end of t3l	25
t3i	Spark pre-ignition time	2
ts	Safety time	5
t4i	Total spark ignition time	10
t4l	Reaction time to achieve safety shutdown due to flame failure	≤ 1
t5i	Spark post-ignition time	3
-	Minimum time to reset the control box using push-button reset	0.4
	Minimum time to reset the control box using remote reset	0.8
tr	Re-cycles: Max. no. 3 repetitions of complete start-up sequence if there is a flame failure during operation; the final action at the last attempt following flame failure is a lock-out	3 re-cycles

* independent by flame control-box

7.8.1 Operations status indication

Status	Reset push-button colour	Seconds		Colour code
OFF	OFF	-	-	-
Pre-heating time (if there is a heater)	GREEN flashing	0.5	2.5	■ □ ■ □ ■ □ ■ □ ■ □
Pre-purge	ORANGE blinking	0.5	0.5	● ○ ● ○ ● ○ ● ○ ● ○
Safety time	GREEN blinking	0.5	0.5	■ □ ■ □ ■ □ ■ □ ■ □
Normal operating position	GREEN*	-	-	Steady ON

7.8.2 Faults diagnosis - lockouts

Fault description	Reset push-button colour	Seconds		Colour code
Extraneous light or parasite flame signal	GREEN, RED blinking alternately	0.5	0.5	■ ▲ ■ ▲ ■ ▲ ■ ▲ ■ ▲
Frequency main supply anomaly	ORANGE	-	-	Steady ON
Internal voltage fault	ORANGE, GREEN fast blinking alternately	0.2	0.2	● ■ ● ■ ● ■ ● ■ ● ■
Reset push-button / Remote reset anomaly	GREEN, RED fast blinking alternately	0.2	0.2	■ ▲ ■ ▲ ■ ▲ ■ ▲ ■ ▲
Lockout for no flame after Ts	RED	-	-	Steady ON
Lockout due to extraneous light or parasite flame signal	RED blinking	0.5	0.5	▲ △ ▲ △ ▲ △ ▲ △ ▲ △
Lockout for maximum number of recycles (flame failure during operation)	RED fast blinking	0.2	0.2	▲ △ ▲ △ ▲ △ ▲ △ ▲ △
Lockout after exceeding max. pre-heating time	RED flashing	0.5	2.5	▲ △ ▲ △ ▲ △ ▲ △ ▲ △
Lockout due to fan motor fault	RED, ORANGE flashing inverted	2.5	0.5	▲ ● ▲ ● ▲ ● ▲ ● ▲ ●
Lockout due to malfunction in the internal control circuit that drives the oil valve	RED, GREEN flashing inverted	2.5	0.5	▲ ■ ▲ ■ ▲ ■ ▲ ■ ▲ ■
Lockout due to eeprom fault	ORANGE, GREEN blinking alternately	0.5	0.5	● ■ ● ■ ● ■ ● ■ ● ■

Key to layout

ON	OFF	Colour code
▲	△	RED
●	○	ORANGE
■	□	GREEN

* The blinking of the LED depends on the quality of flame signal.

7.8.3 Fuel pre-heating function (for burners equipped with heater)

If the burner is equipped with the fuel pre-heating function, in the presence of a start request from the heat request thermostat of the boiler, the burner awaits the closure of the start-up thermostat (or pre-heating, K) positioned on the nozzle holder.

If the start-up thermostat (or the pre-heating one) does not close within 600 seconds, the burner goes into lockout mode.

If the flame goes out during operation, the burner carries out recycling if the contact of the start-up thermostat (or the pre-heating one, K) is closed.

If the flame goes out during operation and the contact of the start up thermostat (or the pre-heating one, K) is open, the purging stops and the burner waiting for the closure of the contact of the start up thermostat (or the pre-heating one, K) to restart with the pre-purging time.

7.8.4 Shutdown test

If, during operations, the reset push-button is pressed for longer than 5 seconds and less than 10 seconds, (so as not to go to the next menu) the burner switches off, the oil valve closes, the flame is extinguished and the starting sequence restarts.

If the switch off test is enabled, the number of repetitions of the start up sequence (see section 7.8.7) and the number of possible resets (see section 7.8.11), are reset.

7.8.5 Diagnosis of the flame signal quality

The burner allows a light diagnosis of the flame during the burner run operation.

Flame quality	Number of green LED blinks
Acceptable	1 - 2 blinks
Good	3 - 4 blinks
Excellent	5 blinks, or always ON

NOTE:

If the detected signal is more than 6 times the minimum threshold value (approximately 3 lux), the green LED will be constant. Otherwise, the number of blinks will indicate the quantity of signal coming from the sensor (no. of blinks * approx. 3 lux). The detected signal depends on the sensitivity of the sensor used, and its tolerance; if the sensor is highly sensitive, the signal level will be high (for the same flame).

Flame detection	Parameters
Type of sensitive element	Photo-conductive cell
Functioning principle	Detection of visible light
Sensitivity to the flame during the pre-purging	> 1 Lux
Typical sensitivity to the flame during normal operation	> 3 Lux
Typical sensitivity to the flame failure	< 2 Lux

NOTE:

With 2 lux, the burner goes into lockout after 3 cycle repeats

7.8.6 Intermittent operation

After (at the most) 24 hours of continuous operation, the control box starts the automatic switch off sequence, followed by a restart, in order to check for a possible fault with the flame sensor.

It is possible to set up this automatic switch off to 1 hour, (see the section 7.10).

7.8.7 Recycle and limit of repetitions

The control box allows a recycle, i.e. complete repetition of the start-up sequence, making up to 3 attempts, in the event the flame failure during operation.

If the flame failure 4 times during operations, this will cause a burner lockout. If there is a new demand for heat during the recycle, the 3 attempts are reset when the limit thermostat (TL) switches.

NOTE:

After 510 seconds of continuous operation, a new attempt of possibility is added.

By disconnecting the power supply, when a new heat request occurs (power supply is applied to the burner) all possible attempts at re-ignition are reset (maximum 3).

7.8.8 Presence of an extraneous light or parasite flame

If when the fan motor starts, during the pre-purging, an extraneous light or parasite flame is detected the burner remains in purging until it disappears or the lockout condition is reached 25 seconds.

If the parasite flame or the extraneous light are detected during the pre-purging, the pre-purging time of 15 seconds is reset and the time for checking for the presence of a parasite flame or extraneous light begins (the motor continues to purge).

The function is cumulative and can be carried out a maximum of 2 times. If at the 24th second the parasite flame or the extraneous light disappears, the pre-purging time starts and if the parasite flame or the extraneous light reappear the pre-purging time is reset and the countdown of 25 seconds for checking for the presence of the parasite flame or the extraneous light restarts.

The third time that the parasite flame or the extraneous light appears the burner goes into lockout.

If during the recycle due to flame disappearance while operating and the consequent repetition of the start-up sequence the parasite flame or the extraneous light is detected, the countdown of 25 seconds starts for checking for the presence of the parasite flame or the extraneous light.

The presence of the parasite flame or extraneous light is also detected in the "t2" state (the burner does not start). The fault is indicated by way of the blinking LED (see section 7.8.2).

7.8.9 Pre and post spark ignition

In the pre-spark ignition time the ignition device starts 2 seconds before the oil valve opens.

In the post-spark ignition time, the ignition device stops 3 seconds after safety time.

The spark ignition is present during all safety time.

NOTE:

In case of continuous recycling or heat requests close to one another, the maximum permissible number of cycle repetitions of the ignition transformer is one attempt every minute.

7.8.10 Reset protection and remote reset

The system will only unlock after the button has been released.

The unit can also be reset via an external button (remote reset) which connects the L terminal (LINE) to the RESET terminal (refer to the wiring diagrams). Max length of external remote reset cable is 3 meters.

7.8.11 Reset push-button anomaly

if the reset push-button or the remote reset breaks or is kept pressed for more than 60 seconds, the fault is indicated by the

blinking of the led (see section 7.8.2) as long as the fault is present.

This fault is merely a visualisation.

- If the fault is detected during pre-purging or safety time, the burner does not stop (the start-up sequence will continue).
- If the fault is detected during operation, the burner does stops and stays stopped with the fault signal active.
- If the fault is detected during a lockout, the fault is not signalled and the burner cannot be reset.
When the fault disappears, the LED stops blinking.

7.8.12 External lockout indicator

The burner is equipped with an external locking signal function, i.e. to signal (together with the integrated reset push-button) a burner locking alarm.

The control box enables the command of an external lamp by way of the exit ⊗ (230Vac-0.5Amp max).

7.8.13 Frequency main supply anomaly

The control-box automatically detects the value of the frequency of the main supply in the range of 50 - 60 Hz, in both cases working times are verified. The fault is indicated by way of the blinking LED (see section 7.8.2).

- If the anomaly is detected before heat demand the burner does not start.
- If the fault is detected during the pre-purging, the burner remains in purge condition and the fault is appropriately signalled.
- If the anomaly is detected during running position the burner remains in operation.
When the anomaly disappears, the burner restarts.

7.8.14 Internal voltage anomaly

The control-box automatically detects if the internal voltage works correctly. The fault is indicated by way of the blinking LED (see section 7.8.2).

- If the anomaly is detected during the initialisation check time, the burner does not start.
- If the anomaly is detected after a lockout the burner does not start.
- If the anomaly is detected after a shutdown test the burner does not start.
- The fault is not detected during normal running, the burner remains in this state.
When the fault disappears, the burner restarts.

7.8.15 Checking the fan motor

The control box automatically detects the presence of the fan motor and, in the event of a fault, it performs a lockout. The lockout is indicated by the blinking led (see section 7.8.2).

7.8.16 Checking the electronic circuit controlling the oil valve

The control box detects the presence of a fault inside the electronic circuit controlling the oil valve, the fault is indicated by the blinking led ("see section 7.8.2"):

- if the anomaly is detected during the initialisation, the burner goes into lockout.
- if the anomaly is detected during the pre-purging, the burner goes into lockout.
- During a recycling, if the fault is detected, the burner does not start and goes into lockout.
- If the anomaly is detected during running position the burner remains in operation.
The fault is not detected if the burner is in lockout.

7.8.17 EEprom check

The control-box automatically detects if EEprom memory of microcontroller has failed and will perform a lockout. The lockout is indicated by blinking led (see section 7.8.2).

7.9 Automatic pre-heating deactivation (for burners equipped with heater)

It is possible to disable the pre-heater function in automatic mode by pressing the reset push-button of the control box or the remote reset.

When the pre-heating is disabled, the pre-heating remains off until:

- a lockout occurs
- the main supply voltage is interrupted
- there is a stop due to intermittent operation.

Pre-heating deactivation sequence	Colour of the button led
Allow the disabling of the pre-heating only when there is no lockout or fault	-
Allow the disabling of the pre-heating using the reset push-button or the remote reset.	-
Supply the burner and simultaneously keep pressed the reset push-button or the remote reset for 3 seconds.	RED
Release the reset push-button or the remote reset within 3 seconds.	OFF
The burner will start disabling the pre-heating only if the reset push-button or the remote reset is released within 3 seconds.	-

The deactivation of the automatic pre-heating function is not lost if the shut-down function is enabled.

Tab. E

7.10 Programming menu

The programming menu can only be accessed via the reset push-button or the remote reset during OPERATION.

If in page menu the reset push-button is not pressed, after 10 seconds occur automatic exit and there is a green led blinking for the value set.

If the number of pressures on the push-button exceeds the maximum allowable, the value in memory will remain the maximum one.

If the push-button or remote reset is pressed for more than 60 seconds, a failure of the push-button will be visualised and the control-box will restart.

BLOCK DIAGRAM FOR ENTERING THE MENU

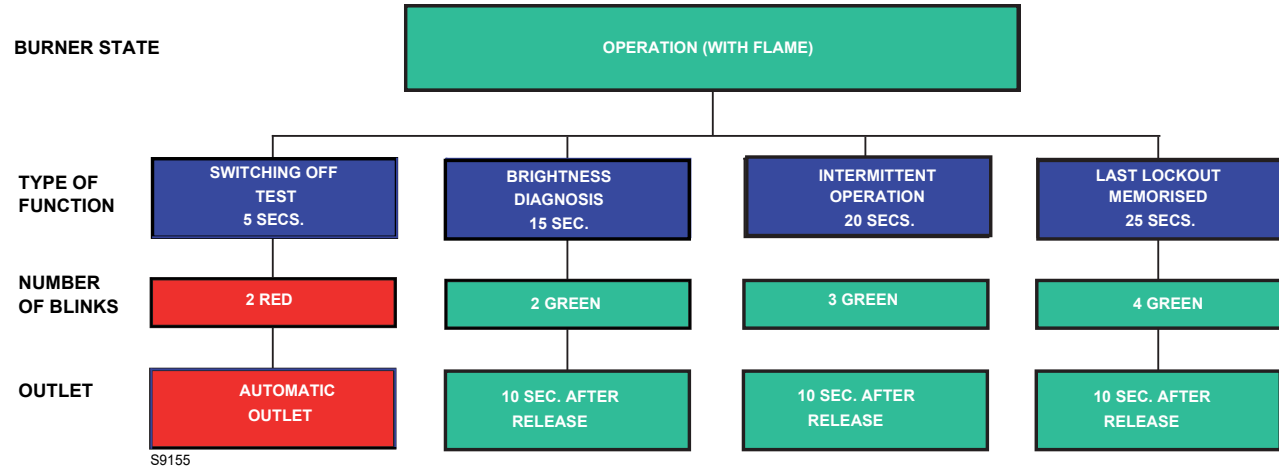

Fig. 24

Function	Button release time	No. of Led blinks per menu page	No. of pressings of the reset push-button	No. of Led blinks (green)	Quitting the menu
Shutdown test	5s ≤ t < 10s	2 blinks RED	/ none	/ none	Automatic, at the end of the blinking
Light diagnosis	15s ≤ t < 20s	2 blinks GREEN	1 = enabled 2 = disabled (default)	1 blink 2 blink	10 sec. after the release of the button
Intermittent operation	20s ≤ t < 25s	3 blinks GREEN	1 = 0 disabled 2 = 1 hour 3 = 24 hours (default)	1 blink 2 blink 3 blink	10 sec. after the release of the button
Last lockout memorised	25s ≤ t < 30s	4 blinks GREEN	/ none	Displaying the type of lockout according to the table section 7.8.2	10 sec. after the release of the button

Tab. F

7.10.1 Shutdown test

Sequence for shutdown test

- Programming allowed in OPERATION.
- Press the button for 5 sec. ≤ t < 10 sec.
- The RED LED blinks twice (0.2 sec. ON; 0.2 sec. OFF)
- Release the button
- The burner will initialise a shutdown followed by a restart

After shutdown, the burner restarts automatically and the number of recycling attempts is restored.

At the exit of shutdown test page menu there are no leds flashing.

7.10.2 Light diagnosis

Sequence for enable/disable

- Programming allowed in OPERATION.
- Press the button for 15 sec. ≤ t < 20 sec.
- GREEN led flashing 2 times
- Release the button
- GREEN led OFF
- Press push-button 1 time for enable or 2 times for disable function (*)

- GREEN led ON and OFF at every press and release
- After 10 sec., the GREEN LED will blink for the number of times programmed (0.5 sec. ON; 0.5 sec. OFF).

7.10.3 Intermittent operation

Sequence for enable/disable

- Programming allowed in OPERATION.
- Press the button for 20 sec. ≤ t < 25 sec.
- GREEN led flashing 3 times
- Release the button
- GREEN led OFF
- Press push-button 1 time for disable function (*)
- Press the button twice to enable a shutdown every 1 hour (*)
- Press the button 3 times to enable a shutdown every 24 hours (*)
- GREEN led ON and OFF at every press and release
- After 10 sec., the GREEN LED will blink for the number of times programmed (0.5 sec. ON; 0.5 sec. OFF)

The modification of the intermittent operation setting parameter takes effect:

- after the activation of a switch-off test;
- after flame disappearance during operation;
- after disconnecting and reconnecting the electrical supply.

- The GREEN led blinks 4 times.
- Release the button.
- Display of the type of lockout stored for 10 sec.

7.10.4 Display of the last lockout that occurred

The control box allows the last lockout that occurred and has been stored to be displayed, by accessing of see “Programming menu” on page 24.

Access to this page is possible only Operating.

Display sequence of the last lockout that occurred

- Keep the button pressed for 25 sec. = t < 30 sec.

The display time for the type of lockout can be extended by pressing the reset push-button during the display of the lockout (the display of the lockout continues for another 10s).

NOTE:

(*) Always wait 1 sec. with each pressing and release of the button to ensure the command is logged correctly.

7.11 Lockout types

Whenever a lockout occurs, the control box shows the reasons for the fault (and the reasons can be identified by the reset push-button colour). The sequence of pulses issued by the control box

of the LED in the reset push-button identifies the possible types of fault, which are listed in the table below

Description	Lockout time	Led colour	Probable cause
Presence of extraneous light during standby	After 25 seconds	▲ ▲ ▲ ▲	- presence of a false flame signal after heat demand.
Pre-heating not terminated (if there is a heater)	After 600 seconds	▲ ▲ ▲ ▲	- fault in the resistor of the oil pre-heater - fault in the switch or start-up thermostat - the short-circuit socket is not connected.
Presence of extraneous light detected during pre-purging	After 25 seconds	▲ ▲ ▲ ▲	- presence of false flame signal during pre-purging.
Extraneous light detected during pre-heating (if there is a heater)	After 25 seconds	▲ ▲ ▲ ▲	- presence of false flame signal during post-purging.
The flame is not detected after the safety time	After 5 seconds from oil-valve starts	RED Steady ON	- flame sensor defective or dirty; - oil valve defective or dirty; - faulty ignition transformer; - badly regulated burner; - oil fuel not present.
Flame failure during operation	After 3 recycles	▲ ▲ ▲ ▲	- badly adjusted burner; - oil valve defective or dirty; - flame sensor defective or dirty.
Fan motor error	Immediate	▲ ● ▲ ●	- faulty fan motor - fan motor not connected
Malfunction in the internal control circuit of the oil valve	Immediate	▲ ■ ▲ ■	- faulty oil valve; - internal control circuit of the oil valve faulty.
Eeprom error	Immediate	● ■ ● ■	- faulty internal memory

Tab. G

Blinking frequency of the reset push-button for status indication, see “Faults diagnosis - lockouts” on page 21.



To reset the control box after visual diagnostics have been displayed, you must press the reset push-button or the remote reset.



In the event the burner stops, in order to prevent any damage to the installation, do not unblock the burner more than twice in a row. If the burner locks out for a third time, contact the customer service.



In the event there are further lockouts or faults with the burner, the maintenance interventions must only be carried out by qualified, authorised personnel, in accordance with the contents of this manual and in compliance with the standards and regulations of current laws.

8 Maintenance

8.1 Notes on safety for the maintenance

The periodic maintenance is essential for the good operation, safety, yield and duration of the burner.

It allows you to reduce consumption and polluting emissions and to keep the product in a reliable state over time.



The maintenance interventions and the calibration of the burner must only be carried out by qualified, authorised personnel, in accordance with the contents of this manual and in compliance with the standards and regulations of current laws.

Before carrying out any maintenance, cleaning or checking operations:



Disconnect the electrical supply from the burner by means of the main system switch.



Close the fuel interception tap.



Wait for the components in contact with heat sources to cool down completely.

8.2 Maintenance programme

8.2.1 Maintenance frequency



The gas combustion system should be checked at least once a year by a representative of the manufacturer or another specialised technician.

8.2.2 Checking and cleaning



The operator must use the required equipment during maintenance.

Combustion head

Open the burner and make sure that all components of the combustion head are in good condition, not deformed by the high temperatures, free of impurities from the surroundings and correctly positioned.

Clean the combustion head in the fuel exit area, on the diffuser disc.

Burner

Check for excess wear or loose screws and clean the outside of the burner.

Fan

Check to make sure that no dust has accumulated inside the fan or on its blades, as this condition will cause a reduction in the air flow rate and provoke polluting combustion.

Flame sensor

Clean the flame sensor.

Electrodes

Check the correct position of electrodes

Nozzles

It is advisable to replace nozzles every year during regular maintenance operations.

Do not clean the nozzle openings; do not even open them.

Filters

Check the filtering baskets on line and at nozzle present in the system. Clean or replace if necessary.

If rust or other impurities are observed inside the pump, use a separate pump to lift any water and other impurities that may have deposited on the bottom of the tank.

Pump

Please check that the supply line and filters are clear. The use of a pump vacuum gauge will assist in this. This measure permits the cause of the anomaly to be traced to either the suction line or the pump.

If the problem lies in the suction line, check to make sure that the filter is clean and that air is not entering the piping.

Hoses

- Check periodically the flexible pipes conditions. They have to be replaced at least **every 2 years**.
- In case of use of gas oil and bio fuel blends, it is strongly recommended to inspect **even more frequently** the hoses and replace them where contamination has occurred.
- Check to make sure that the hoses are still in good condition.



The hoses supplied with this burner set for Kerosene use are not suitable for use with Gas oil containing a Bio blend.

Please refer to the spare part list for the specific hoses suitable for bio fuel use.

In case of use with gas oil containing up to 10% Bio blend, it will be essential to use flexible oil lines suitable for bio fuel use.

Please contact Riello for further information.



Any contact with elements such solvents, thinners or cleaning fluids that have a polar base, along with any aggressive elements present within the fuel will void any warranty of the flexible hose.

Fuel tank

If water or contamination is present within the fuel tank, it is essential that this is removed before the equipment is to be used. This is extremely important when gas oil containing Bio diesel is in use. If in doubt about how to achieve this then please contact the fuel or oil tank supplier.

Boiler

Clean the boiler as indicated in the appliance accompanying instructions in order to maintain all the original combustion characteristics intact, especially the flue gas temperature and combustion chamber pressure.

Combustion

In case the combustion values found at the beginning of the intervention do not respect the standards in force or, in any case, do not correspond to a proper combustion, contact the Technical Assistant and have him carry out the necessary adjustments.

Allow the burner to work for 10 min. and then check the combustion readings with the parameters indicated within the appliance instruction manual.

Then carry out a combustion check verifying:

- Smoke temperature at the chimney;
- Content of CO₂ (%);
- Content of CO (ppm);
- Smoke value according to opacity smokes index according to Bacharach scale.

8.2.3 Safety components

The safety components must be replaced at the end of their life cycle indicated in Tab. H. The specified life cycles do not refer to the warranty terms indicated in the delivery or payment conditions.

Safety component	Life cycle
Flame control	10 years or 250,000 operation cycles
Flame sensor	10 years or 250,000 operation cycles
Gas valves (solenoid)	10 years or 250,000 operation cycles
Pressure switches	10 years or 250,000 operation cycles
Pressure adjuster	15 years
Servomotor (electronic cam) (if present)	10 years or 250,000 operation cycles
Oil valve (solenoid) (if present)	10 years or 250,000 operation cycles
Oil regulator (if present)	10 years or 250,000 operation cycles
Oil pipes/ couplings (metallic) (if present)	10 years
Fan impeller	10 years or 500,000 start-ups

Tab. H**8.3 Opening the burner**

Disconnect the electrical supply from the burner by means of the main system switch.



Turn off the fuel interception tap.



Wait for the components in contact with heat sources to cool down completely.



After carrying out maintenance, cleaning or checking operations, reassemble the hood and all the safety and protection devices of the burner.

9 Faults - Probable causes - Solutions

Here below you can find some causes and the possible solutions for some problems that could cause a failure to start or incorrect operation of the burner.

A fault usually makes the lockout led signal which is situated inside the reset push-button of the control box.

When the lockout lamp comes on, the burner will only attempt to start up after the reset push-button has been pressed. If ignition is then normal, the stop can be attributed to a temporary fault that is not dangerous.

If however the lock out continues the cause must be determined and the solution found.

Faults	Possible cause	Fault diagnostics	Solutions
The burner does not start when there is heat demand.	Lack of electrical supply.	OFF	Check presence of voltage in the L - N the pin plug. Check the conditions of the fuses. Check that safety thermostat is not lock out.
	The flame sensor sees false light.	■▲■▲	Eliminate the extraneous light.
	The connections in the control box are wrongly inserted.	OFF	Check and connect all the plugs and sockets properly.
	The heater is faulty or the P short-circuit socket is not connected (if there is not a heater).	■□■□■	Replace them.
The burner goes into lockout mode before or during the pre-purging.	The flame sensor sees extraneous light.	▲▲▲▲	Eliminate the extraneous light.
Burner runs normally in the pre-purge and ignition cycle and locks out after 5 seconds ca.	The flame sensor is dirty.	RED Steady ON	Clear it.
	The flame sensor is faulty.		Replace it.
	Flame moves away or fails.		Check pressure and output of the fuel. Check air output. Change nozzle. Check the coil of solenoid valve.
Burner starts with an ignition delay.	The ignition electrodes are wrongly positioned.	OFF	Adjust them according to the instructions of this manual.
	Air output is too high.		Set the air output according to the instructions of this manual.
	Nozzle dirty or worn.		Replace it.

Tab. I



WARNING

The manufacturer cannot accept responsibility for any damage to persons, animals or property due to error in installation or in the burner adjustment, or due to improper or unreasonable use or non observance of the technical instruction enclosed with the burner, or due to the intervention of un-qualified personnel.

RIELLO

RIELLO S.p.A.
I-37045 Legnago (VR)
Tel.: +39.0442.630111
[http:// www.riello.it](http://www.riello.it)
[http:// www.riello.com](http://www.riello.com)