

ENG

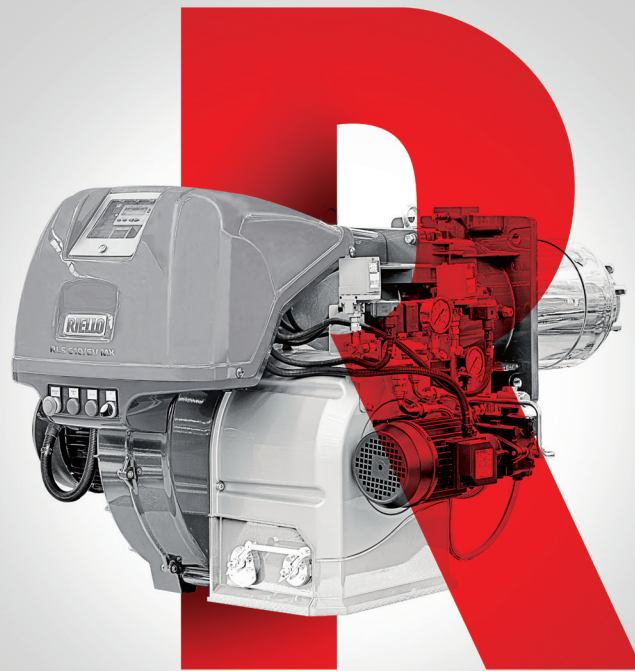

INTERNATIONAL TECHNICAL SALES BURNERS CATALOGUE

Africa / Asia / Europe / Oceania / South America

September 2019

www.riello.com

RIELLO
Energy For Life

2019

RIELLO

RIELLO
BURNERS

RIELLO

RIELLO

RIELLO

RIELLO
ISOTHERMO



OFFICINE RIELLO
FRATELLI RIELLO



OFFICINE RIELLO
FRATELLI RIELLO

F.lli RIELLO
OFFICINA MECCANICA = LEONARDO PORTO

1922

WE TRANSFORM ENERGY FROM NATURE INTO AN EXTENSIVE PRODUCT PORTFOLIO THAT ENSURES WELL-BEING IN MILLIONS OF HOMES AND STRUCTURES ALL OVER THE WORLD, WITH RESPECT FOR THE ENVIRONMENT AND PASSION, THANKS TO AN ORGANISATION AND A SALES NET THAT FIND IN THE KNOW-HOW AND FIGURES THEIR DISTINCTIVE FORCE.

RIELLO,
A VALUABLE
REALITY



Riello's strength is the result of its technological innovation capacities and the experience it has acquired in over 90-year history. The reliability of a team of technicians, professionals and collaborators who are called upon every day to make their own contribution in terms of hard work, skill and creativity is a great value. Thanks to their commitment, and the use of innovative projects and ideas, Riello is now the Italian leader in the production of systems and technologies for every type of environment. This leading role means that new products are created every year, based on groundbreaking technology to ensure the efficient use of energy and

an improvement in the quality of the atmosphere and the well-being of the entire community. The figures are the most effective guarantee of this promise. The industrial organization currently boasts 8 production plants, Research Centres for product development, and a Combustion Research Centre that is one of the best in the world. The company's presence on worldwide markets is distinguished by a well-constructed and efficient sales network, alongside many important Training Centres located in various countries. Riello has 13 operational branches abroad (in Europe, America and Asia), with customers in over 60 countries.

RIELLO, A WORLDWIDE PRESENCE

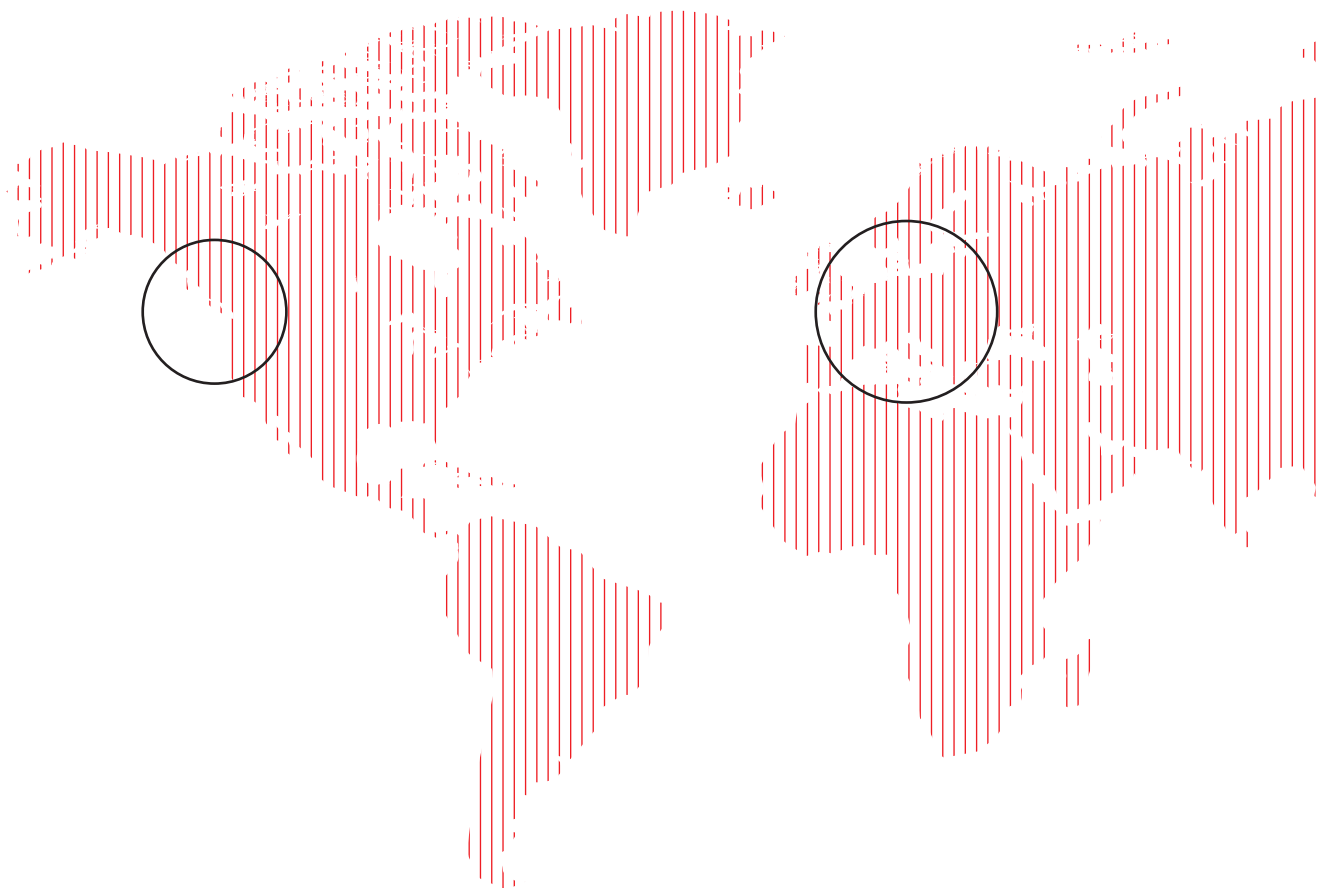

RIELLO CANADA Inc. (Canada)
RIELLO Corp. of America (USA)

RHE BEIJING Branch (China)
RIELLO Japan Inc. (Japan)
RIELLO SINGAPORE Pte. Ltd.
(Singapore)

RIELLO S.p.A. (Italy)
FIT SERVICE S.p.A. (Italy)
RIELLO Ltd. (UK)
RIELLO S.p.A. Deutschland (Germany)
RIELLO S.A. (Switzerland)
RIELLO FRANCE S.A. (France)
RIELLO RO S.r.l. (Romania)
RIELLO PALNIKI Sp.Zo.o. (Poland)
CIS RIELLO S.p.A. (Russian Federation)

With operational branches and commercial partnerships organized in a well-structured and efficient sales network, Riello is present in over 60

countries. Riello puts a great deal of emphasis on after-sales support, with a technical service team, technical training courses and

an engineering team ensuring that you get training and service support whenever needed, together with the availability of original spare-parts.

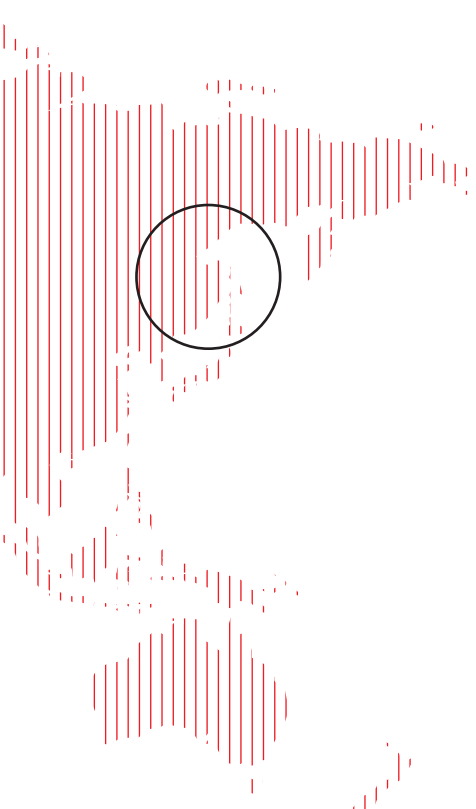

EVERY DAY WE DESIGN AND DEVELOP TOP QUALITY PRODUCTS THAT ESTABLISH NEW REFERENCE STANDARDS IN TERMS OF PERFORMANCE, PRACTICALITY, ENERGY SAVING AND SUSTAINABILITY.

The concentration on industrial processes and the ongoing investment in research are the factors that have allowed Riello to improve the productivity of its plants and identify new development areas. If, on one side, the traditional work sectors have seen an increase in the range of high efficiency applications (such as gas and light oil condensing boilers), on the other side there is a focus on new technologies combining energy efficiency and reduction of polluting emissions with the use of renewable energies.

Such a wide range of products has notably increased the company's levels of competitiveness, so that it is now able to meet all its customers' needs, from domestic applications to commercial and industrial systems. In particular, Riello is now orientating its offer towards integrated systems, consisting in the combination of products and components whose specific characteristics result in customized and highly efficient solutions, for every kind of building, while constantly respecting the environment.

RIELLO,
ALWAYS AT
YOUR SERVICE



ONLINE
TRAINING



ON-SITE
TRAINING

Since the beginning training is an integrated part of Riello business and a distinctive element recognized by the market for consistency and coherence. Riello attention is to transfer the knowledge and competence with a process of continuing training, both for employees and for customers/partners.

An activity that is characterized by a program of meetings for technical updating and specific training courses dedicated to professional growth of technician and installers. Professionalism, competence and reliability are daily made available to favor the complete knowledge of products and system solutions of the latest generation.

Training for Riello means also to know the evolution of the Regulation and be able to interpret in advance their development. The organization of Riello presales and training is ready to offer a continuous support and the best training courses to its Customers, essential tools to face a market constantly changing.

The new training center in Angiari (Legnago, Verona) is a concrete example of the importance of training for Riello. The new facility, recently opened, has classrooms and equipped laboratories to provide theoretical and practical training, using the most modern learning systems.

How to use this catalogue

This catalogue contains information to help you in selecting the right burner for any problem of heat production. There are the following sections:

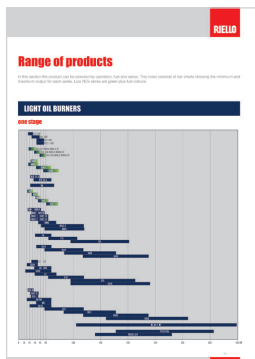

pag. 9
Range of Products

In this section the product can be selected by operation, fuel and series. This index consists of bar charts showing the minimum and maximum output for each series. Low NOx series are green plus fuel colours.

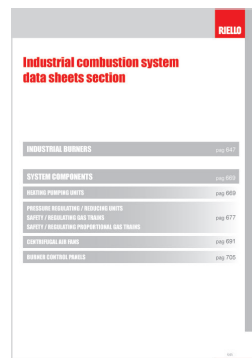

pag. 743
Industrial Combustion System Data Sheets Section

This section contains the technical sheet for all components needed to carry out a complete industrial burner system.

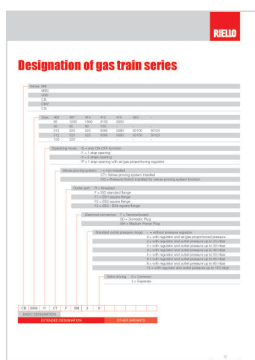

pag. 14
Designation of Gas Train Series

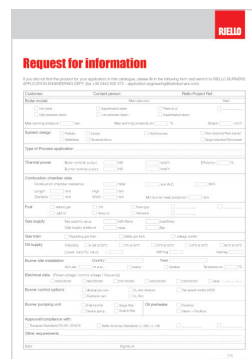

pag. 783
Request for Information

You can ask information for Riello Burners Technical Office directly using a special form.



pag. 15
Index

In this section the product can be selected by operation, fuel and series. For each series there are:

- a picture
- series name
- models in the series
- output range
- technical sheet page number.

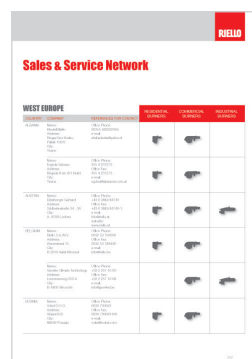

pag. 785
Sales and Service Network

In this section you will find the Riello Burners distributors around the world and the references for the contact.

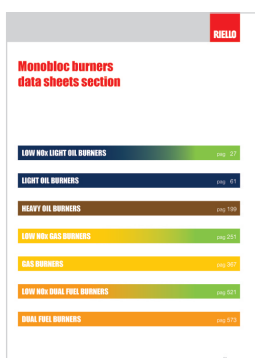







pag. 29
Monobloc Burners Data Sheets Section

This section contains the technical sheets of monobloc burners, divided by fuel, series and operation.

Fuels and associated colour identification

In the catalogue each colour represents a different fuel so that a fuel type can be matched to a series of burners. For low NOx burners the green colour is associated with fuel type color.



MONOBLOC BURNERS

	LOW NOx LIGHT OIL BURNERS
	LIGHT OIL BURNERS
	HEAVY OIL BURNERS
	LOW NOx GAS BURNERS
	GAS BURNERS
	LOW NOx DUAL FUEL BURNERS
	DUAL FUEL BURNERS

ULTRA LOW NOx BURNERS

	PREMIX BURNERS
	FGR GAS BURNERS

PROCESS BURNERS

	OVENS BURNERS
	HIGH RATIO ADJUSTMENT BURNERS
	AIR DUCT BURNERS

INDUSTRIAL COMBUSTION SYSTEM

	INDUSTRIAL BURNERS
	SYSTEM COMPONENTS

Range of products

In this section the product can be selected by operation, fuel and series. This index consists of bar charts showing the minimum and maximum output for each series. Low NOx series are green plus fuel colours.

LIGHT OIL BURNERS

one stage

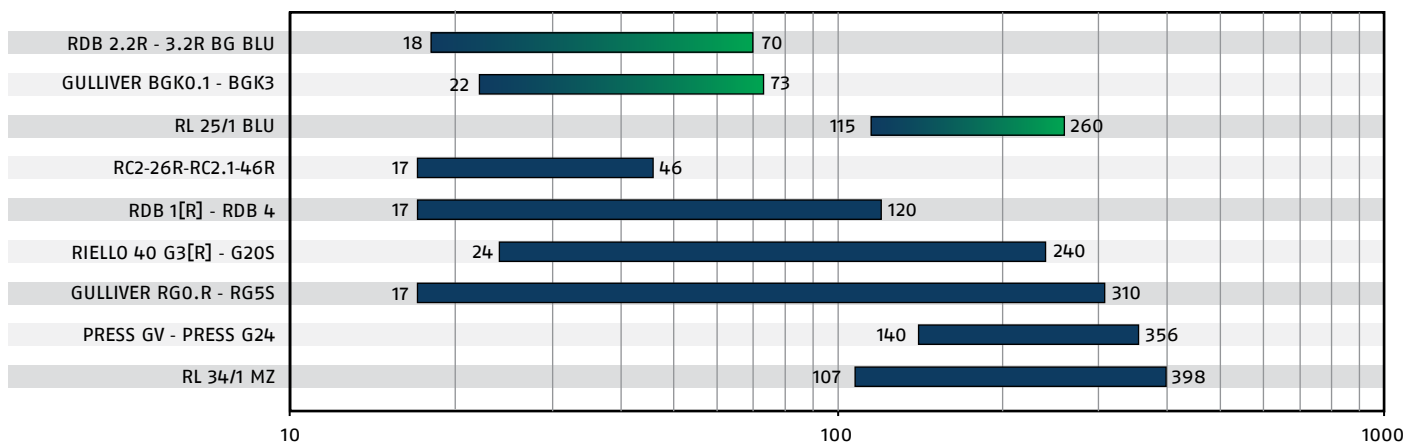

two stage

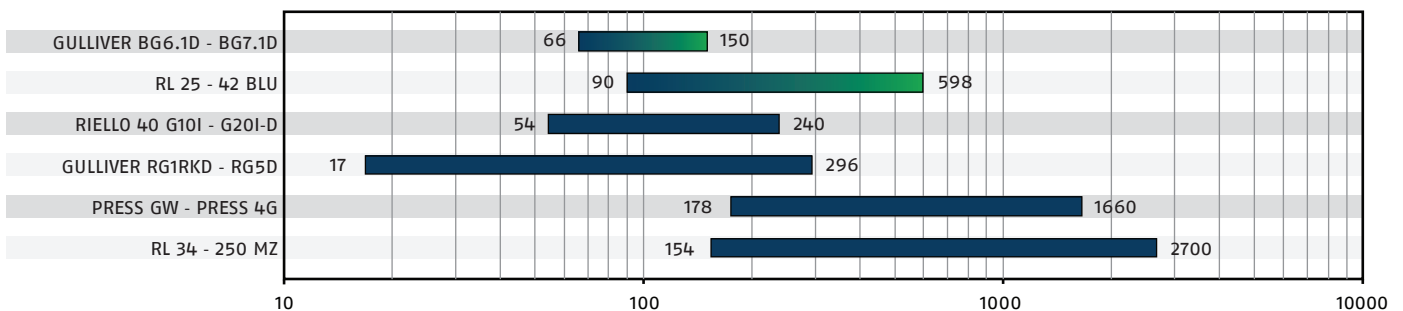

three stage

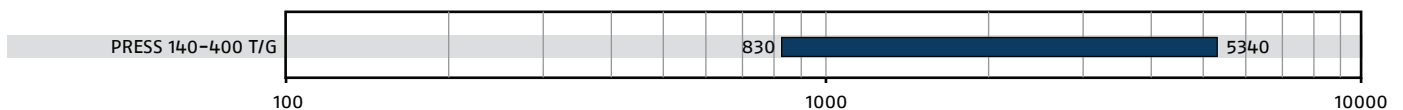

two stage-progressive/modulating

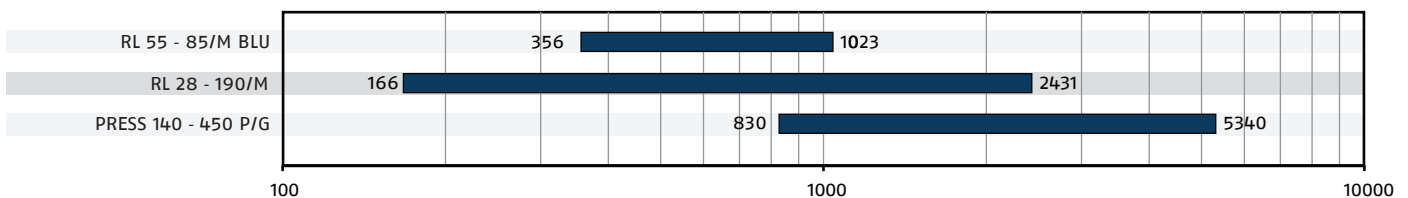

HEAVY OIL BURNERS

one stage

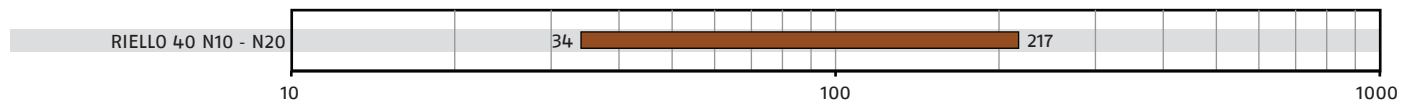

two stage

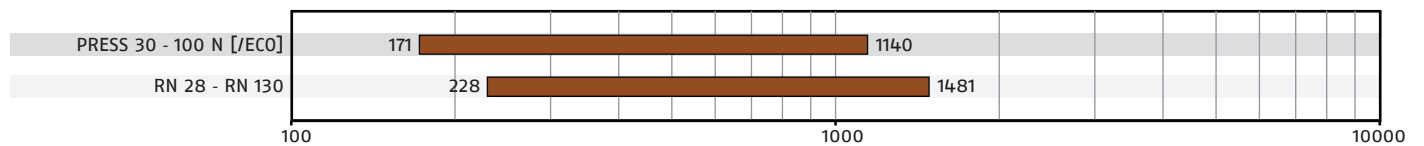

three stage

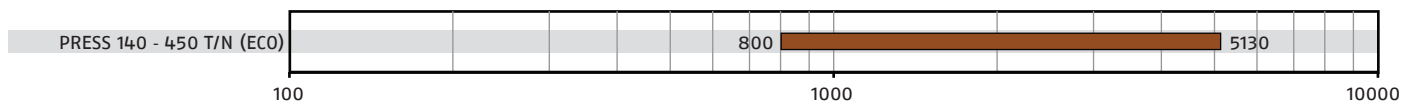

two stage-progressive/modulating

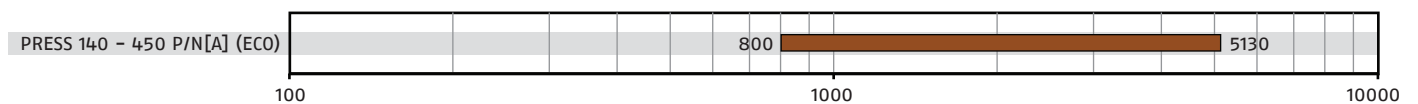

GAS BURNERS

one stage

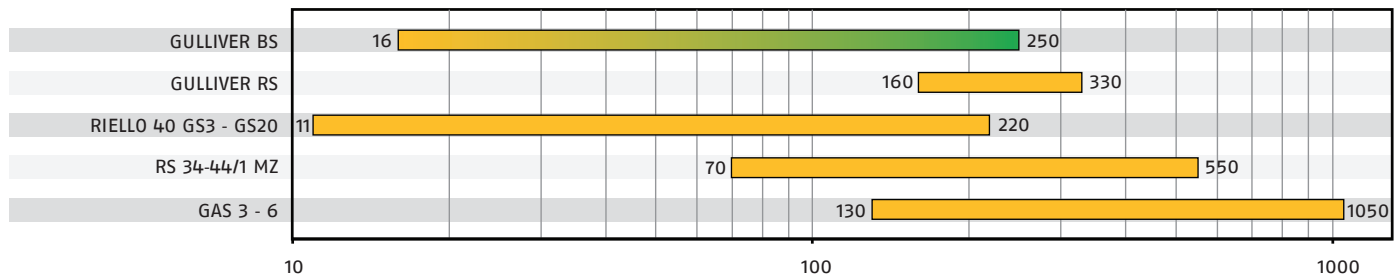

two stage

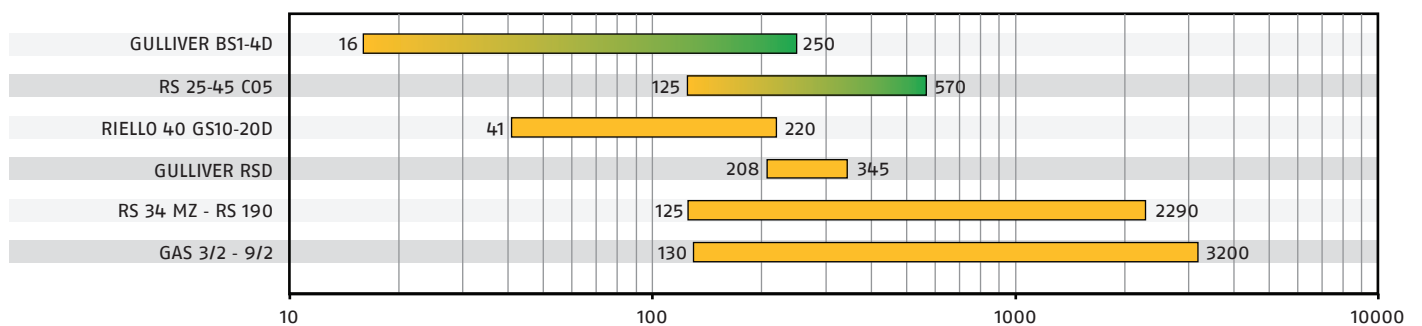

two stage-progressive/modulating

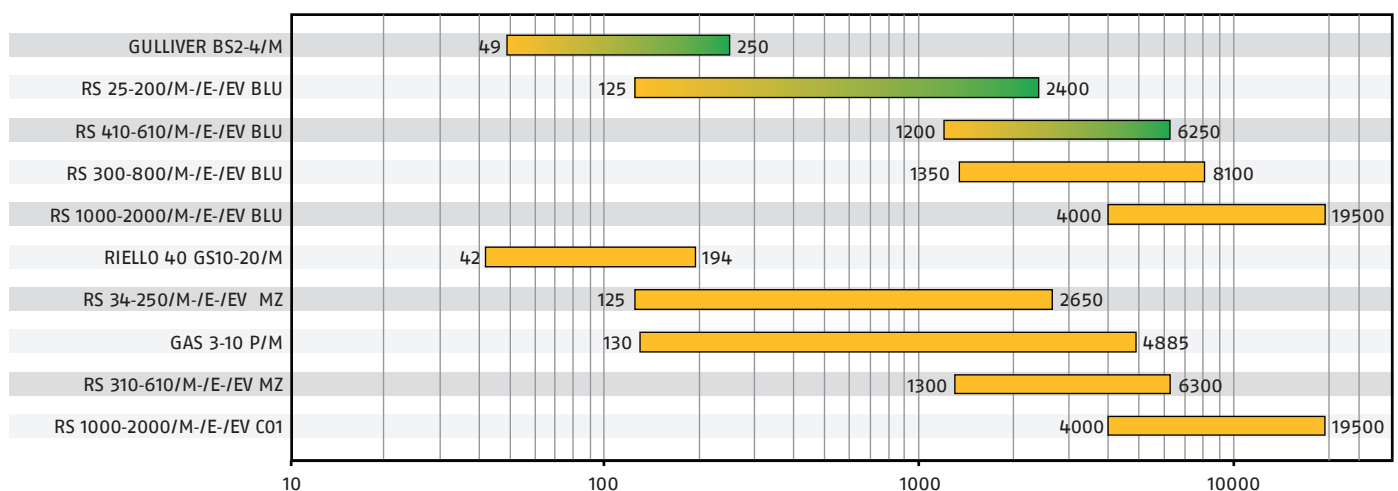

Range of products

DUAL FUEL BURNERS

two stage

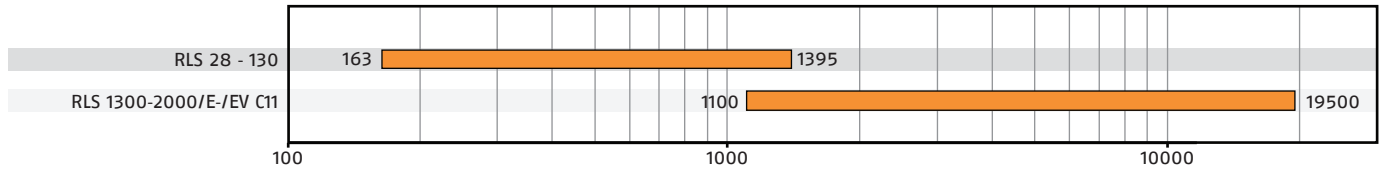

two stage-progressive/modulating

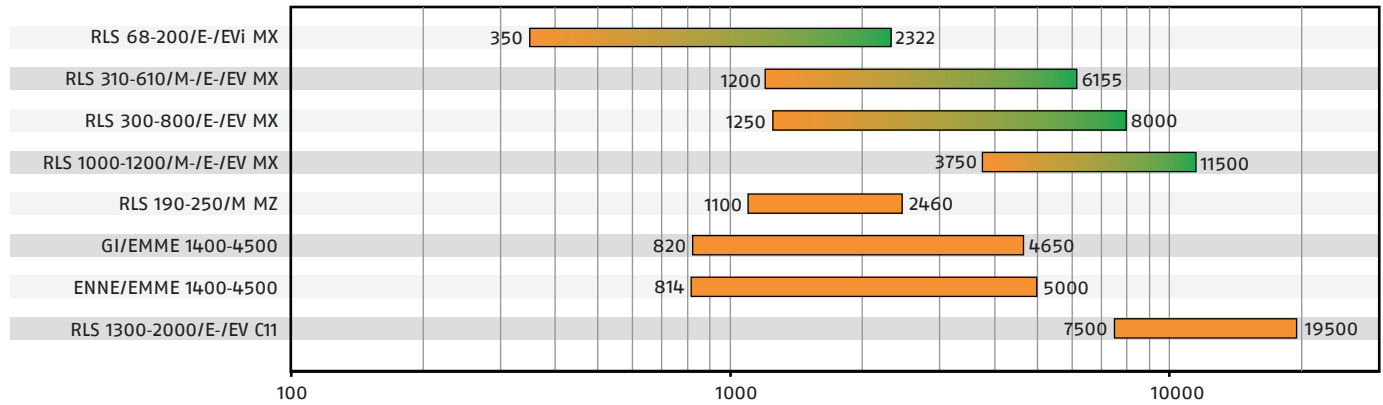

ULTRA LOW NOx BURNERS

modulating

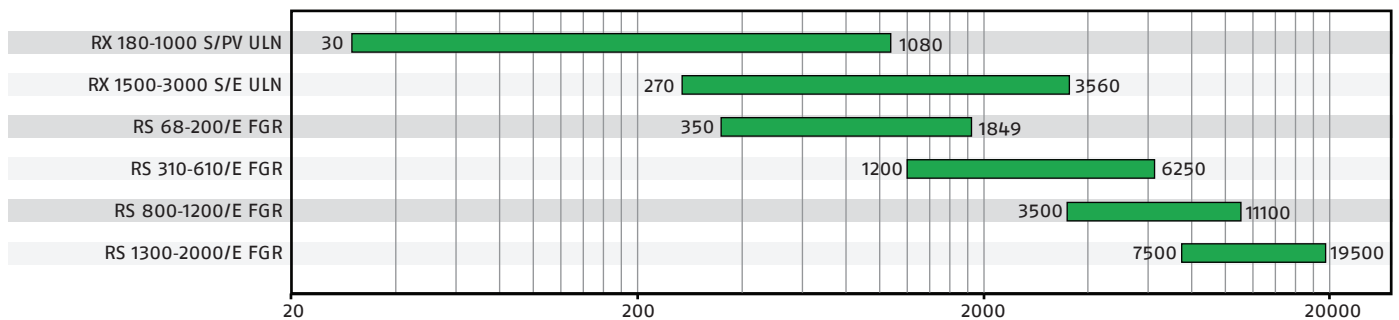

PROCESS BURNERS

ovens burners

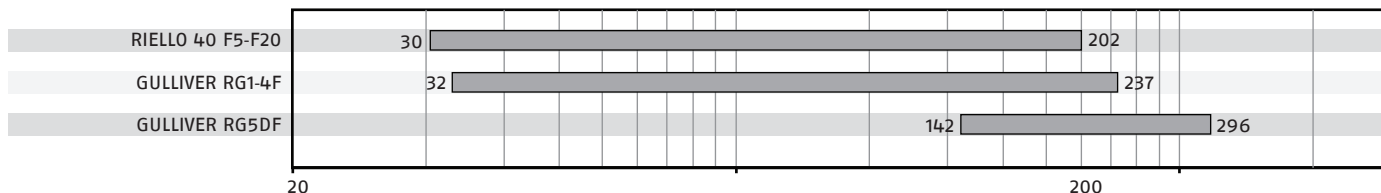
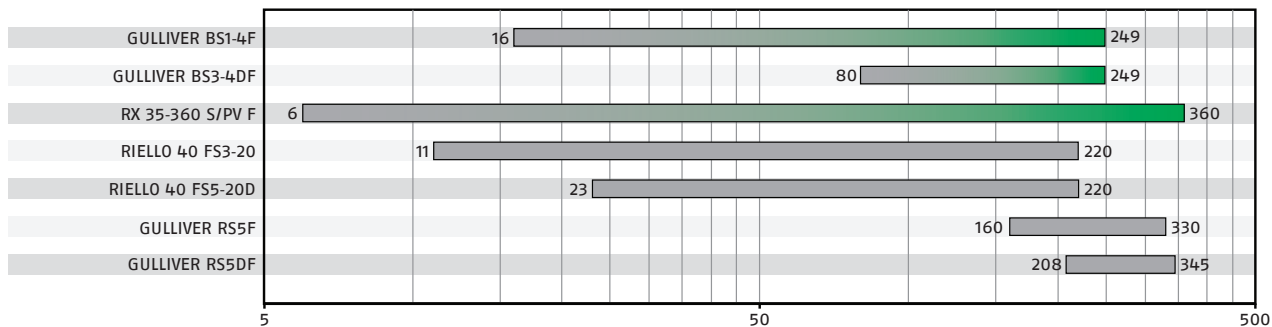

air duct burners



high ratio adjustment burners

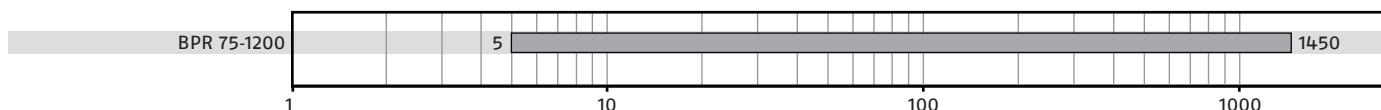

OIL, GAS and DUAL FUEL INDUSTRIAL BURNERS

DB - ER series - all fuels

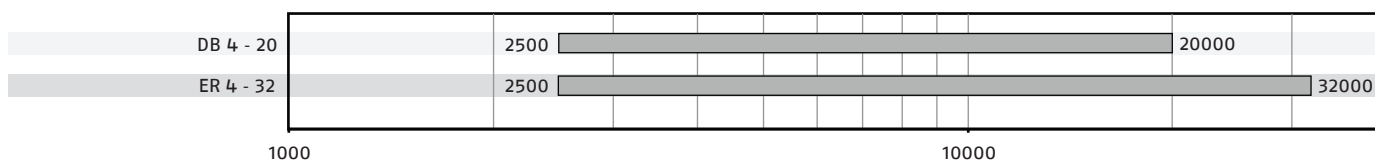

These data are indicative for all fuels.

Designation of gas train series

Series: MB

MBC

VGD

CB

DMV

CG

Size:	405	407	410	412	415	420	-
	65	1200	1900	3100	5000		
	50	65	80	100	-	-	-
	512	520	525	5065	5080	50100	50125
	512	520	525	5065	5080	50100	50125
	120	220	-	-	-	-	-

Operating mode: /S = only ON-OFF function

/1 = 1 step opening

/2 = 2 steps opening

/P = 1 step opening with air/gas proportioning regulator

Valves proving system: - = non installed

CT= Valves proving system installed

CQ = Pressure Switch installed for valves proving system function

Outlet port: R = threaded

F = ISO standard flange

F1 = BS1 square flange

F2 = BS2 square flange

F3 = BS3 - BS4 square flange

Electrical connecton: T = Terminal board

SD = Domestic Plug

SM = Medium Power Plug

Standard outlet pressure range: - = without pressure regulator

0 = with regulator and air/gas proportioned pressure

2 = with regulator and outlet pressure up to 20 mbar

3 = with regulator and outlet pressure up to 30 mbar

4 = with regulator and outlet pressure up to 40 mbar

5 = with regulator and outlet pressure up to 50 mbar

6 = with regulator and outlet pressure up to 60 mbar

8 = with regulator and outlet pressure up to 80 mbar

15 = with regulator and outlet pressure up to 150 mbar

Valve driving: 0 = Common

2 = Separate

CB	5065	/1	CT	F	SM	3	0						
----	------	----	----	---	----	---	---	--	--	--	--	--	--

BASIC DESIGNATION

EXTENDED DESIGNATION

OTHER VARIANTS

Index

LOW NOx LIGHT OIL BURNERS

RDB BG BLU SERIES



RDB BG BLU SERIES
RDB 2.2R BG BLU - RDB 3.2R BG BLU

18 ÷ 70 kW

Low NOx
One Stage

pag 31

GULLIVER SERIES



GULLIVER BGK
BGK0.1 - BGK1 - BGK2 - BGK3

17,8 ÷ 72 kW

Low NOx
One Stage

pag 35



GULLIVER BG.1D
BG6.1D - BG7.1D

65,2 ÷ 160 kW

Low NOx
Two Stage

pag 41

RL SERIES



RL BLU
RL 25/1 BLU

115 ÷ 260kW

Low NOx
One Stage

pag 47



RL BLU
RL 25 BLU - 35 BLU - 42 BLU

115 ÷ 598 kW

Low NOx
Two Stage

pag 53



RL/M BLU
RL 55/M BLU - 85/M BLU

356 ÷ 1023 kW

Low NOx
Modulating

pag 61

LIGHT OIL BURNERS

RDB SERIES



RDB

RDB1 - RDB1R - RDB2 - RDB2R -
RDB2.1 - RDB2.1R - RDB2.2 - RDB2.2R
RDB2.2 GKD - RDB3 - RDB3.2 - RDB4

16,8 ÷ 120 kW

One Stage

pag 67

RC SERIES



RC

RC2-26R - RC2-38 - RC2-38R - RC2-46R
RC2.1-46 - RC2.1-46R

17 ÷ 46 kW

One Stage

pag 73

GULLIVER SERIES



GULLIVER RG

RG0.1 - RG1 - RG2 - RG3 - RG4S - RG5S
RG0.R - RG0.1R - RG1R - RG1RK

15 ÷ 309,5 kW

One Stage

pag 79



GULLIVER RGD

RG1RKD - RG2D - RG3D - RG4D - RG5D

17 ÷ 296 kW

Two Stage

pag 87

RIELLO 40 SERIES



RIELLO 40 G

G3 - G5 - G7 - G10 - G20 - G20S
G3R - G3RK - G5R - G5RK

12 ÷ 240 kW

One Stage

pag 93



RIELLO 40 GI

G10I - G20I - G20D

54 ÷ 240 kW

Two Stage

pag 101

RL SERIES



RL/1
RL 34/1 MZ

107 ÷ 398 kW

One Stage pag 107

RL
RL 34 MZ - 44 MZ - 50 - 64 MZ
RL 70 - 100 - 130 - 190 - 250 MZ

154 ÷ 2700 kW

Two Stage pag 115

RL/M
RL 28/M - 38/M - 50/M
RL 70/M - 100/M - 130/M - 190/M

166 ÷ 2431 kW

Modulating pag 127

PRESS SERIES



PRESS GV
PRESS GV - G24

140 ÷ 356 kW

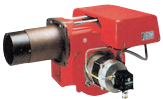
One Stage pag 135

PRESS G
PRESS GW - 1G - 2G - 3G - 4G

178 ÷ 1660 kW

Two Stage pag 141

PRESS T/G
P 140T/G - 200T/G - 300T/G - 450T/G

830 ÷ 5340 kW

Three Stage pag 149

PRESS P/G
P 140P/G - 200P/G - 300P/G - 450P/G

830 ÷ 5340 kW

Modulating pag 157

HEAVY OIL BURNERS

RIELLO 40 SERIES



RIELLO 40 N
N10 - N20

34 ÷ 217 kW

One Stage

pag 165

RN SERIES

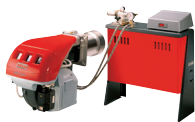

RN
RN 28 - 38 - 50 - 70 - 100 - 130

228 ÷ 1481 kW

Two Stage

pag 169

PRESS SERIES



PRESS N
P 30N - 45N - 60N - 100N

171 ÷ 1140 kW

Two Stage

pag 175



PRESS N/ECO
P 30N/ECO - 45N/ECO
P 60N/ECO - 100N/ECO

171 ÷ 1140 kW

Two Stage

pag 183



PRESS T/N - T/N ECO
P 140T/N (ECO) - 200T/N (ECO)
P 300T/N (ECO) - 450T/N (ECO)

800 ÷ 5130 kW

Three Stage

pag 191



PRESS P/N - P/N ECO
P 140P/N (ECO) - 200P/N (ECO)
P 300P/N (ECO) - 450P/N (ECO)

800 ÷ 5130 kW

Modulating

pag 199



PRESS P/NA - P/NA ECO
P 140P/NA (ECO) - 200P/NA (ECO)
P 300P/NA (ECO) - 450P/NA (ECO)

800 ÷ 5130 kW

Modulating

pag 207

LOW NO_x GAS BURNERS

GULLIVER SERIES



GULLIVER BS
BS1 - BS2 - BS3 - BS4

16 ÷ 249 kW

**Low NO_x
One Stage**

pag 217



GULLIVER BSD
BS1D - BS2D - BS3D - BS4D

19 ÷ 249 kW

**Low NO_x
Two Stage**

pag 223



GULLIVER BS/M
BS1/M - BS2/M - BS3/M - BS4/M

49 ÷ 250 kW

**Low NO_x
Modulating**

pag 229

RS SERIES



RS 25÷45 C05
RS 25 - 35 - 45 C05

125 ÷ 570 kW

**Low NO_x
Modulating**

pag 235



RS 25÷200/M BLU
RS 25/M - 35/M - 45/M C05
RS 25/M - 35/M - 55/M - 68/M BLU
RS 120/M - 160/M - 200/M BLU

125 ÷ 2400 kW

**Low NO_x
Modulating**

pag 243



RS 25÷200/E-EV BLU
RS 25/E - 35/E - 45/E C05
RS 25/E - 35/E - 55/E - 68/E-EV BLU
RS 120/E-EV - 160/E-EV - 200/E-EV BLU

125 ÷ 2400 kW

**Low NO_x
Modulating**

pag 259



RS 310÷810/M BLU
RS 310/M - 410/M - 510/M BLU
RS 610 - 810/M BLU

1200 ÷ 8010 kW

**Low NO_x
Modulating**

pag 273



RS 310÷810/E-/EV BLU
RS 310/E-EV - 410/E-EV BLU
RS 510/E-EV - 610/E-/EV - 810/E-EV BLU

1200 ÷ 8010 kW

**Low NO_x
Modulating**

pag 285

RS SERIES



RS 1000÷1200/M BLU
RS 1000/M - 1200/M BLU

4000 ÷ 11100 kW

**Low NOx
Modulating**

pag 297



RS 300÷2000/E-EV BLU
RS 300/E-EV - 400/E-EV - 500/E-EV BLU
RS 650/E-EV BLU
RS 1000/E-EV - 1200/E-EV BLU
RS 1300/E-EV - 1600/E-EV BLU
RS 2000/E-EV BLU

1350 ÷ 19500 kW

**Low NOx
Modulating**

pag 307

GAS BURNERS

RIELLO 40 SERIES



RIELLO 40 GS
GS3 - GS5 - GS10 - GS20

11 ÷ 220 kW

One Stage

pag 325



RIELLO 40 GSD
GS10D - GS20D

41 ÷ 220 kW

Two Stage

pag 331

RIELLO 40 SERIES



RIELLO 40 GS/M
GS10/M - GS20/M

42 ÷ 194 kW

Modulating

pag 337

GULLIVER SERIES



GULLIVER RS
RS5

160 ÷ 330 kW

One Stage

pag 343



GULLIVER RSD
RS5D

208 ÷ 345 kW

Two Stage

pag 349

RS SERIES

**RS/1**

RS 34/1 MZ - 44/1 MZ

70 ÷ 550 kW

One Stage

pag 355

**RS**RS 34 MZ - 44 MZ - 50 - 64 MZ
RS 70 - 100 - 130 - 150 - 190

130 ÷ 2290 kW

Two Stage

pag 365

**RS/M**RS 34/M MZ - 44/M MZ - 50/M MZ
RS 64/M MZ - 70/M - 100/M - 130/M
RS 150/M - 190/M - 250/M MZ

130 ÷ 2650 kW

Modulating

pag 381

**RS/E-EV MZ**RS 34/E MZ - 44/E MZ - 50/E MZ
RS 64/E MZ - 70/E - 100/E
RS 130/E - 190/E - 250/E-EV MZ

130 ÷ 2650 kW

Modulating

pag 399

**RS 310÷610/M MZ**

RS 310/M MZ- 410/M MZ- 510/M MZ- 610/M MZ

1300 ÷ 6300 kW

Modulating

pag 413

**RS 310÷610/E-/-EV MZ**RS 310/E-EV MZ - 410/E-EV MZ
RS 510/E-EV MZ - 610/E-EV MZ

1300 ÷ 6300 kW

Modulating

pag 425

**RS/M C01**

RS 1000-1200/M C01

4000 ÷ 11100 kW

Modulating

pag 437

**RS/E-EV C01**RS 1000-1200/E-EV C01
RS 1300E-EV-1600/E-EV-2000/E-EV C01

4000 ÷ 19500 kW

Modulating

pag 445

GAS SERIES



GAS

GAS 3 - 4 - 5 - 6

130 ÷ 1050 kW

One Stage

pag 457



GAS/2

GAS 3/2 - 4/2 - 5/2 - 6/2 - 7/2 - 9/2

130 ÷ 3200 kW

Two Stage

pag 467



GAS P/M

GAS 3P/M - 4P/M - 5P/M - 6P/M - 7P/M
GAS 8P/M - 9P/M - 10P/M

130 ÷ 4885 kW

Modulating

pag 477

LOW NOx DUAL FUEL BURNERS

RLS SERIES



RLS/M MX

RLS 68/M MX - 120/M MX - 160/M MX

350 ÷ 1840 kW

**Low NOx
Modulating**

pag 489



RLS 310÷610/M MX

RLS 310/M MX - 410/M MX
RLS 510/M MX - 610/M MX

600 ÷ 6155 kW

**Low NOx
Modulating**

pag 499



RLS 800÷1200/M MX

RLS 800/M MX
RLS 1000/M - 1200/M

3500 ÷ 11500 kW

**Low NOx
Modulating**

pag 511



RLS/E-EV MX

RLS 68/E-EVi MX - 120/E-EVi MX
RLS 160/E-EVi MX - 200/E-EVi MX

350 ÷ 2322 kW

**Low NOx
Modulating**

pag 523

LOW NOx DUAL FUEL BURNERS



RLS 310÷610/E MX

RLS 310/E MX - 410/E MX
RLS 510/E MX - 610/E MX

600 ÷ 6155 kW

Low NOx
Modulating

pag 535



RLS 300÷1200/E-EV MX

RLS 300/E-EV MX - 400/E-EV MX
RLS 500/E-EV MX - 650/E-EV MX
RLS 800/E-EV MX - 1000/E-EV - 1200/E-EV MX

1250 ÷ 11500 kW

Low NOx
Modulating

pag 547

DUAL FUEL BURNERS

RLS SERIES



RLS

RLS 28 - 38 - 50 - 70 - 100 - 130

163 ÷ 1395 kW

Two Stage

pag 561



RLS/M MZ

RLS 190/M MZ - 250/M MZ

1100 ÷ 2460 kW

Modulating

pag 571

GI/EMME SERIES



GI/EMME 1400÷4500

GI/EMME 1400 - 2000 - 3000 - 4500

820 ÷ 4650 kW

Modulating

pag 581



RLS 1300÷2000/E-/EV C11

RLS 1300/E-/EV - 1600/E-/EV - 2000/E-/EV C11

7500 ÷ 19500 kW

Modulating

pag 591

ENNE/EMME SERIES



ENNE/EMME

ENNE/EMME 1400 - 2000 - 3000 - 4500

814 ÷ 5000 kW

Modulating

pag 603

ULTRA LOW NOx GAS BURNERS

PREMIX GAS BURNERS



RX 180÷1000 S/PV ULN

RX 180-250-360-500-
700-850-1000 S/PV ULN

30 ÷ 970 kW

Low NOx
Modulating

pag 615



RX 1500÷3000 S/E ULN

RX 1500-1800-
2500-3000 S/E ULN

270 ÷ 3210 kW

Low NOx
Modulating

pag 623

FGR GAS BURNERS



RS 68÷2000/E FGR

RS 68-120-160-200-310-
410-510-610-800-1000-
1200-1300-1600-2000/E FGR

195 ÷ 19500 kW

Low NOx
Modulating

pag 631

LIGHT OIL PROCESS BURNERS

RIELLO 40 F SERIES (OVENS BURNERS)



RIELLO 40 F

F5 - F10 - F20

30 ÷ 202 kW

One Stage

pag 647

GULLIVER RG SERIES (OVEN BURNERS)



GULLIVER RGF

RG1F - RG2F - RG3F - RG4F

32 ÷ 237 kW

One Stage

pag 653



GULLIVER RGDF

RG5DF

142 ÷ 296 kW

Two Stage

pag 659

GAS PROCESS BURNERS

GULLIVER BS SERIES (OVEN BURNERS)



GULLIVER BSF
BS1F - BS2F - BS3F - BS4F

16 ÷ 249 kW

One Stage pag 663

GULLIVER BSDF
BS3DF - BS4DF

75 ÷ 249 kW

Two Stage pag 669

RIELLO 40 SERIES (OVEN BURNERS)



RIELLO 40 FS
FS3 - FS5 - FS8 - FS10 - FS15 - FS20

11 ÷ 220 kW

One Stage pag 675

RIELLO 40 FSD
FS5D - FS20D

23 ÷ 220 kW

Two Stage pag 683

GULLIVER RS SERIES (OVEN BURNERS)



GULLIVER RSF
RS5F

160 ÷ 330 kW

One Stage pag 689

GULLIVER RSDF
RS5DF

208 ÷ 345 kW

Two Stage pag 695

RX S/PV SERIES (OVEN BURNERS)



RX S/PV F
RX 35 S/PV F - RX 70 S/PV F - RX 150 S/PV F
RX 250 S/PV F - RX 180 S/PV F - RX 360 S/PV F

6 ÷ 360 kW

Modulating pag 701

AIR DUCT BURNERS



RS VA SERIES

RS 5 VA - RS 28 VA - RS 38 VA
RS 50 VA - RS 70 VA

20 ÷ 900 kW

Modulating pag 711



RX S/PV VA SERIES

RX 180 S/PV VA - RX 250 S/PV VA
RX 290 S/PV VA - RX 310 S/PV VA - RX 400 S/PV VA

25 ÷ 400 kW

Modulating pag 721

BP R SERIES (HIGH RATIO ADJUSTMENT BURNERS)



BP R

75 - 150 - 300 - 450 - 600 - 800 - 1200

5 ÷ 1450 kW

Modulating pag 727

INDUSTRIAL BURNERS

DB SERIES



DB

DB 4 - 6 - 9 - 12 - 16 - 20

2500 ÷ 20000 kW

pag 733

ER SERIES



ER

ER 4 - 6 - 9 - 12 - 16 - 20 - 25 - 32

2500 ÷ 32000 kW

pag 741

SYSTEM COMPONENTS

HEATING PUMPING UNITS



SG - DG

250 ÷ 2000 l/h pag 749



SN - DN

250 ÷ 2100 l/h pag 749

PRESSURE REGULATING / REDUCING UNITS



LPRT

LPRT 40 - 80 - 160 - 250 - 500 - 750 - 1000 - 1500 - 2000

< 500 mbar pag 753



HPRT

HPRT 80 - 160 - 250 - 500 - 750 - 1000 - 1500 - 2000

0,5 ÷ 4 bar pag 753

SAFETY / REGULATING GAS TRAINS



CB

CB 512/1 - 520/1 - 525/1
 CB 5065/1 - 5080/1 - 50100/1 - 50125/1
 CB 512/1 CT - 520/1 CT - 525/1 CT - 5065/1 CT
 CB 5080/1 CT - 50100/1 CT - 50125/1 CT

< 500 mbar pag 753



MBC

MBC 1200/1 - RSM 60 / MBC 1200/1 CT RSM 60

< 360 mbar

MBC 1900/1 - FSM 40 / MBC 1900/1 CT FSM 40

pag 753

MBC 3100/1 - FSM 40 / MBC 3100/1 CT FSM 40

< 500 mbar

MBC 5000/1 - FSM 80 / MBC 5000/1 CT FSM 80

SAFETY / REGULATING PROPORTIONAL GAS TRAINS

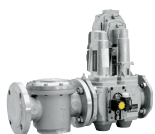

VGD

VGD 50 - VGDF 65 - VGDF 80 - VGDF 100

< 500 mbar pag 753

SAFETY / WORKING VALVES



DMV

DMV 512 - 520 - 525 - 5065 - 5080 - 50100 - 50125

< 500 mbar

pag 753

CENTRIFUGAL AIR FANS

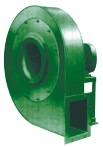

GCH - GCM - GBS

pag 767

BURNER CONTROL PANELS



QE

for DB and ER series

-

pag 769

Monobloc burners data sheets section

LOW NO_x LIGHT OIL BURNERS

pag. 31

LIGHT OIL BURNERS

pag. 67

HEAVY OIL BURNERS

pag. 165

LOW NO_x GAS BURNERS

pag. 217

GAS BURNERS

pag. 325

LOW NO_x DUAL FUEL BURNERS

pag. 489

DUAL FUEL BURNERS

pag. 561

Ultra low NO_x burners data sheets section

PREMIX BURNERS

pag. 615

FGR GAS BURNERS

pag. 631

Process burners data sheets section

OVEN BURNERS

pag. 647

AIR DUCT BURNERS

pag. 711

HIGH RATIO ADJUSTMENT BURNERS

pag. 727

RDB BG BLU SERIES

The RDB BG BLU series offers a new technical solutions for gasoil residential applications, developed to reduce the emissions level below the new limits set by the latest European environmental regulation, the Energy-related Product Directive 2018 (ErP).

The new RDB BG is developed on two platforms , the 2.2R and the 3.2R, covering a power range from 18 up to 70 kW with a complete blue flame combustion.

Thanks to their compact size and great ventilation performance, the RDB BG represent the ideal matching with compact, high efficiency heating boilers.

Moreover, the burners have been developed on a flexible platform , allowing a complete customization for the specific need of any customer. All the most critical combustion parameters can be tailor-fitted to the peculiar boiler characteristics

The RDB BG BLU are available also for Kerosene fuel.

Guidelines for installation of burners in conformity to EU Regulation:

A RIELLO burner (Heat Generator), where it is matched with a water-based boiler (Heater Housing) with a nominal output ≤ 400 kW, providing heat for heating purposes and heat to deliver sanitary hot water, can be installed:

- With boilers (heater housings) already in service in the field, for replacement of identical products, in conformity to Article 1, paragraph 2, point (G) of the EU Regulation No. 813/2013;
- With boilers (heater housings) on a new installation.

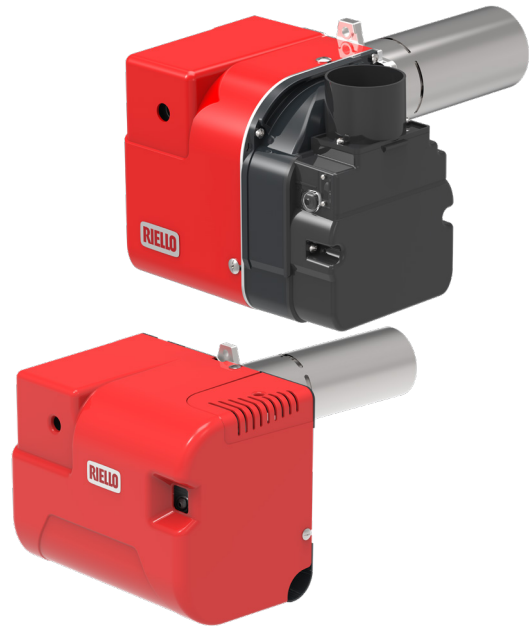

FIRING RATES

The RDB BG BLU burner, depending on the backpressure available, can be set at the specific power output required by the customer's boiler.

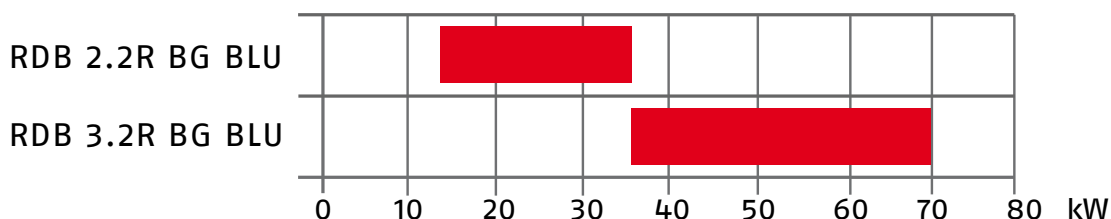

Low NOx One Stage Light Oil Burners

RDB BG BLU SERIES

Overall dimensions (mm)

BURNER

RDB 2.2R BG BLU

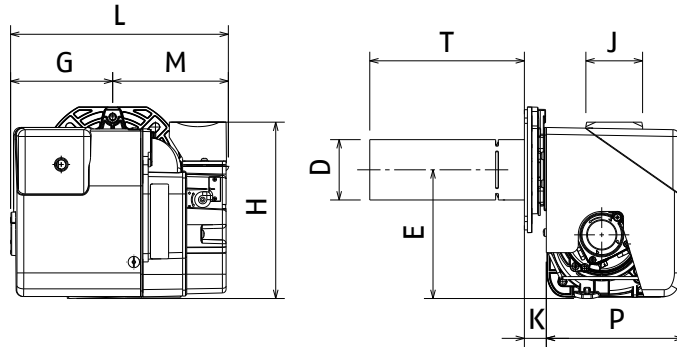

RDB 3.2R BG BLU

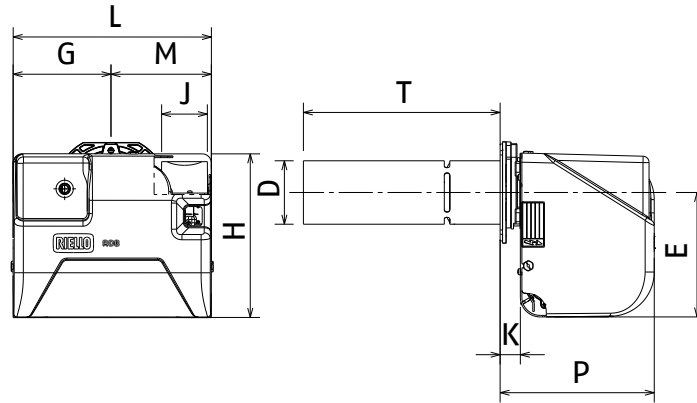

MODEL	D*	E	G	H	K	L	M	P	T*	J
▶ RDB 2.2R BG BLU	80	170	135	235	29	288	153	210	204	75
▶ RDB 3.2R BG BLU	97	204	160	268	33	325	165	253	258	75

* Head dimensions could vary depending on performance required by the matching with the boiler

BURNER - BOILER MOUNTING FLANGE

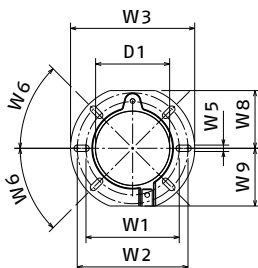

MODEL	D1	W1	W2	W3	W5	W8	W9
▶ RDB 2.2R BG BLU	106	150	156	189	11	83	83
▶ RDB 3.2R BG BLU	105	146	160	190	11	83	83

PACKAGING

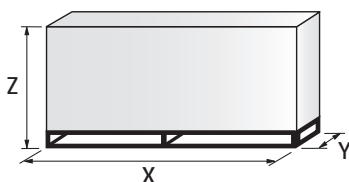

MODEL	X	Y	Z	kg
▶ RDB 2.2R BG BLU	465	300	315	10
▶ RDB 3.2R BG BLU	670	365	370	13

Specification

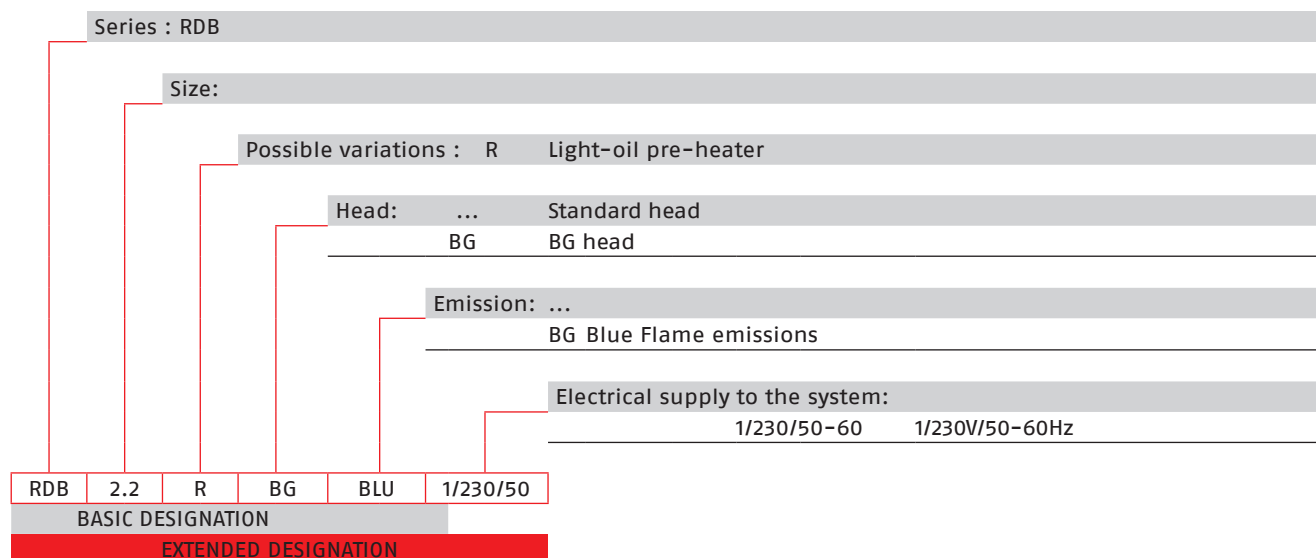

STATE OF SUPPLY

Completely automatic monobloc light oil one stage operation burner, made up of:

- Fan with forward inclined blades
- Air damper with external adjustment, with no need to remove the cover
- Air-tight air circuit
- BG Low NOx Combustion head
- Geared pump for fuel supply, fitted with filter
- Pressure regulator
- Fuel pre-heater
- Fuel feed solenoid valve incorporated in the pump
- UV sensor for flame detection
- Digital equipment for flame control
- Light oil nozzle
- Stop-drop hydraulic system
- IP 20 electrical protection level

Standard equipment (to be customized according to customer needs):

- Flexible pipes for connection to the light oil supply line
- Nipples for connection to the pump
- Flange, screws and nuts for fixing
- Thermal screen
- Instruction handbook for installation, use and maintenance
- Spare parts catalogue.

Available models

CODE	MODEL	HEAT OUTPUT		TOTAL ELECTRICAL POWER (kW)	NOTE
		(kW)	(kg/h)		
(A)	RDB 2.2R BG BLU 1/230/50	18 - 35	1.52 - 2.95	0.16	(1)
(A)	RDB 3.2R BG BLU 1/230/50	35 - 70	3 - 5.9	0.24	(1)

(1) All burner models are OEM's customized.

(A) Please contact Riello Burners Commercial and Technical Department, our Application Engineers will be pleased to help you.

Net calorific value: 11,8 kWh/kg - 10200 kcal/kg - Viscosity at 20°C: 4-6 mm²/s (cSt)

The RDB BG BLU burners are in according to 2014/30/EU - 2014/35/EU - 2006/42 EC Directive and EN 267.

Low NOx One Stage Light Oil Burners

RDB BG BLU SERIES

Overall dimensions (mm)

Balanced-conventional flue conversion kit

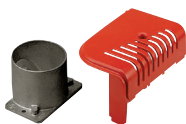

All the RDB series models are easily converted from conventional flue to balanced flue, by replacing the plastic screen on the air intake with the connector for the air supply pipe.

BURNER	BALANCED FLUE KIT CODE	CONVENTIONAL FLUE KIT CODE
► RDB 2.2R BG BLU	(A)	(A)
► RDB 3.2R BG BLU	(A)	(A)

(A) Please contact Riello Burners Commercial and Technical Department, our Application Engineers will be pleased to help you.

Light oil filter



For cleaning light oil from dirty particles and impurities filters with the following features are available:

BURNER	FILTERING DEGREE (µm)	KIT CODE
► All models	60	3006561

Filter made up of aluminium body and stainless steel filtering cartridge; available singularly.

BURNER	FILTERING DEGREE (µm)	KIT CODE
► All models	60	3075011

Filter made up of aluminium cover, plastic tank and nylon filtering cartridge; available in packaging of 50 pieces.

Light oil filter/degassing unit



To solve problems of air or water in the oil circuit a special filter/degassing unit is available, made up of aluminium cover, plastic tank, stainless steel filtering cartridge, air release cap and water purge valve. It is available singularly.

BURNER	FILTERING DEGREE (µm)	KIT CODE
► All models	100	3000926

GULLIVER BGK SERIES

The Riello Gulliver BGK series of one stage light oil burners is a complete range of Low NOx products developed to respond to any request for home heating, conforming to the strictest standards regarding the reduction of polluting emissions. The BGK series is available in four models with an output ranging from 17.8 to 73 kW, divided in two different structures.

All the models use the same components designed by Riello for the Gulliver series.

The high quality level guarantees safe working. The Gulliver BGK burners are fitted with a microprocessor-based control box, with diagnostic functions.

In developing these burners, special attention was paid to reducing noise, to ease of installation and adjustment, to obtaining the smallest size possible to fit into any sort of boiler available on the market.

All the models are approved by the European EN 267 Standard and conform to European Directives for EMC, Low Voltage, Machinery and Boiler Efficiency.

All the Gulliver BGK series of burners are fired before leaving the factory.

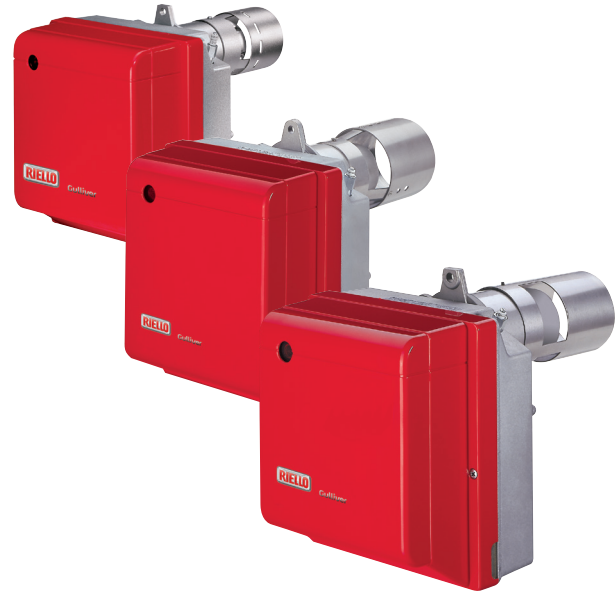

Guidelines for installation of burners in conformity to EU Regulation:

A RIELLO burner (Heat Generator), where it is matched with a water-based boiler (Heater Housing) with a nominal output ≤ 400 kW, providing heat for heating purposes and heat to deliver sanitary hot water, can be installed:

- With boilers (heater housings) already in service in the field, for replacement of identical products, in conformity to Article 1, paragraph 2, point (G) of the EU Regulation No. 813/2013;
- With boilers (heater housings) on a new installation.

BGK0.1	22,5 ÷ 35,3 kW
BGK1	17,8 ÷ 35,6 kW
BGK2	32,0 ÷ 59,3 kW
BGK3	45,0 ÷ 73,0 kW

FIRING RATES

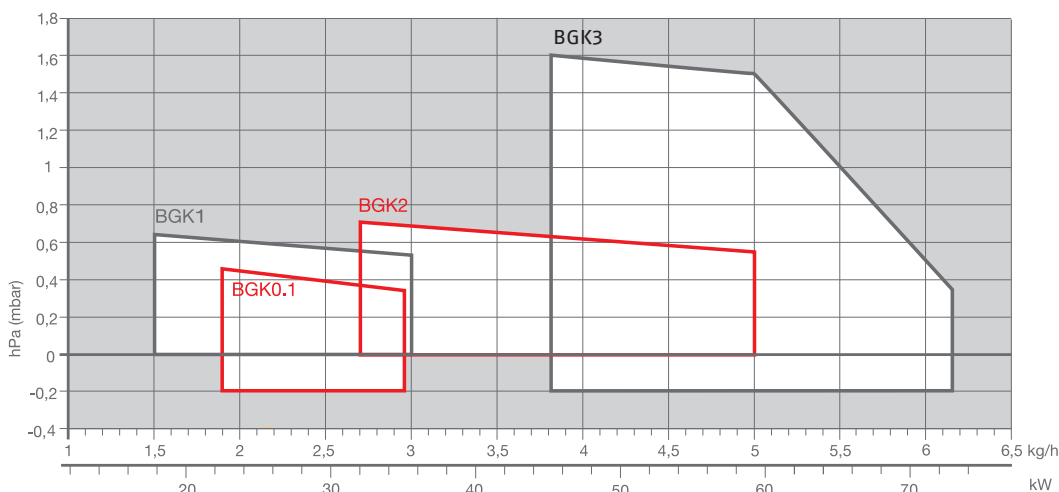

Useful working field for choosing the burner

Test conditions conforming to EN267
 Temperature: 20°C
 Pressure: 1013,5 mbar
 Altitude: 0 m a.s.l.

Low NOx One Stage Light Oil Burners

GULLIVER BGK SERIES

Overall dimensions (mm)

BURNER

BGK0.1

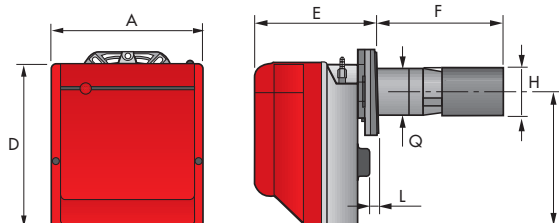

BGK1 - BGK2 - BGK3

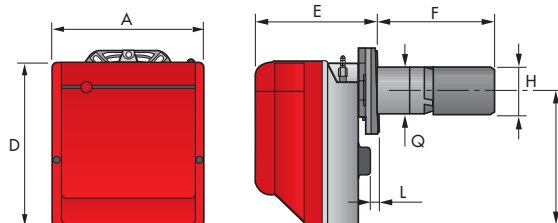

MODEL	A	D	E	F	H	I	L	Q
▶ BGK0.1	234	254	196	191	87	210	4	84
▶ BGK1	255	280	202	192	87	230	10	89
▶ BGK2	255	280	202	197	90	230	10	89
▶ BGK3	300	345	230	222	90	285	12	89

IMPORTANT: Boiler door must have a max. thickness of 70 mm for BGK0.1, 80 mm for BGK1 and 90 mm for BGK2 and BGK3, refractory lining included.

BURNER - BOILER MOUNTING FLANGE

BGK0.1

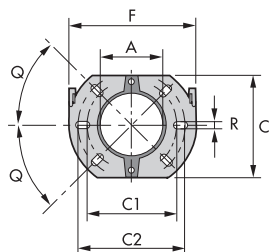

BGK1 - BGK2 - BGK3

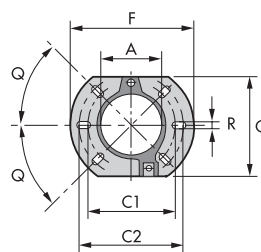

MODEL	A	C	C1	C2	F	Q	R
▶ BGK0.1	91	144	130	150	180	45°	11
▶ BGK1	106	166	140	168	189	45°	11
▶ BGK2	106	166	140	168	189	45°	11
▶ BGK3	106	166	140	168	189	45°	11

PACKAGING

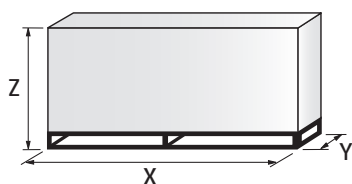

MODEL	X	Y	Z	kg
▶ BGK0.1	343	268	310	13
▶ BGK1	533	288	340	13
▶ BGK2	533	288	340	13
▶ BGK3	430	345	430	16,5

Specification

DESIGNATION OF SERIES

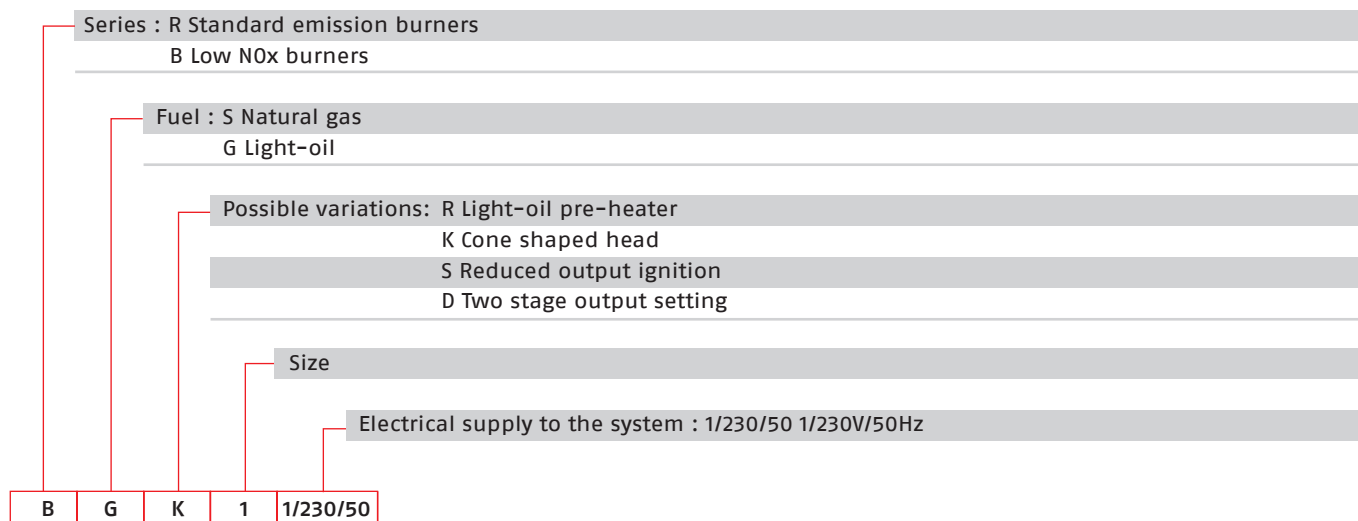

STATE OF SUPPLY

Completely automatic monobloc light oil burners, with one stage operation fitted with:

- Fan with forward inclined blades
- Sound deadening cover
- Air damper with external adjustment, with no need to remove the cover
- Single phase electric motor 230 V, 50 Hz
- Combustion head, fitted with:
 - stainless steel end cone resistant to high temperatures
 - ignition electrodes
 - flame stability disk
- Geared pump for fuel supply, fitted with:
 - filter
 - pressure regulator
 - connectors for installing a pressure gauge and vacuumeter
 - internal by-pass for preparing for single pipe installation
- Post-ignition of 3 seconds after safety time
- Fuel feed solenoid incorporated in the pump
- Photocell for flame detection with optical fibre
- Microprocessor-based burner safety control box MO 550, with diagnostic and remote control release functions (BGK1 - BGK2 - BGK3 models)
- Protection filter against radio interference (included into burner safety control box)
- Light oil nozzle
- IP X0D (IP 40) electric protection level
- PTC fuel heater.

Standard equipment:

- Flange with insulating gasket
- Screws and nuts for flange
- Recirculating pipe
- Four screws and nuts for flange to be fixed to boiler
- Remote control release kit
- Two flexible oil pipes with nipples
- 7-pin plug kit
- Instruction handbook for installation, use and maintenance
- Spare parts catalogue.

Low NOx One Stage Light Oil Burners

GULLIVER BGK SERIES

Available models

CODE	MODEL	HEAT OUTPUT		TOTAL ELECTRICAL POWER (kW)	NOTE
		(kW)	(kg/h)		

MODELS WITH ANALOGIC CONTROL BOX

3737511	BGK0.1 1/230/50	22,5 - 35,3	1,9 - 2,95	0,220	
---------	-----------------	-------------	------------	-------	--

MODELS WITH DIGITAL CONTROL BOX MO 550

3737066	BGK1 1/230/50	17,8 - 35,6	1,5 - 3	0,250	
3737456	BGK2 1/230/50	32 - 59,3	2,7 - 5	0,250	
20012189	BGK3 1/230/50	45 - 73	3,8 - 6,15	0,460	

Net calorific value: 11,8 kWh/kg; 10200 kcal/kg - Viscosity at 20°C: 4±6 mm²/s (cSt).
 The burners of BGK series are in according to 2014/30/EU - 2014/35/EU - 2006/42 EC Directive and EN 267.

Burner accessories

Light oil filter



For cleaning light oil from dirty particles and impurities filters with the following features are available:

BURNER	FILTERING DEGREE (µm)	KIT CODE
► All models	60	3006561

Filter made up of aluminium body and stainless steel filtering cartridge; available singularly.

BURNER	FILTERING DEGREE (µm)	KIT CODE
► All models	60	3075011

Filter made up of aluminium cover, plastic tank and nylon filtering cartridge; available in packaging of 50 pieces.

Light oil filter/degassing unit



To solve problems of air or water in the oil circuit a special filter/degassing unit is available, made up of aluminium cover, plastic tank, stainless steel filtering cartridge, air release cap and water purge valve. It is available singularly.

BURNER	FILTERING DEGREE (µm)	KIT CODE
► All models	100	3000926

7-pin plug kit

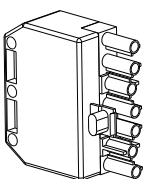

If necessary a 7-pin plug kit is available (in packaging of n. 5 pieces).

BURNER	KIT CODE
► All models	3000945



We are here

**providing reliable use of
energy for your applications**



FACCI & POLINI

GULLIVER BGD SERIES

The Riello Gulliver BGD series of two stage light oil burners is a complete range of Low NOx products, developed to respond to any request for home heating, conforming to the strictest standards governing the reduction of polluting emissions. The Gulliver BGD series is available in two different models, with an output ranging from 53,8 to 149,5 kW, divided in two different structures.

All the models use the same components designed by Riello for the Gulliver series. The high quality level guarantees safe working. The Gulliver BGD burners are fitted with a microprocessor-based control box, with diagnostic functions.

In developing these burners, special attention was paid to reducing noise, to the ease of installation and adjustment, to obtaining the smallest size possible to fit into any sort of boiler available on the market.

The two stage operation guarantees high level of thermal unit efficiency.

All the models are approved by the EN 267 European Standard and conform to European Directives for EMC, Low Voltage, Machinery and Boiler Efficiency.

All the Gulliver BGD burners are fired before leaving the factory.

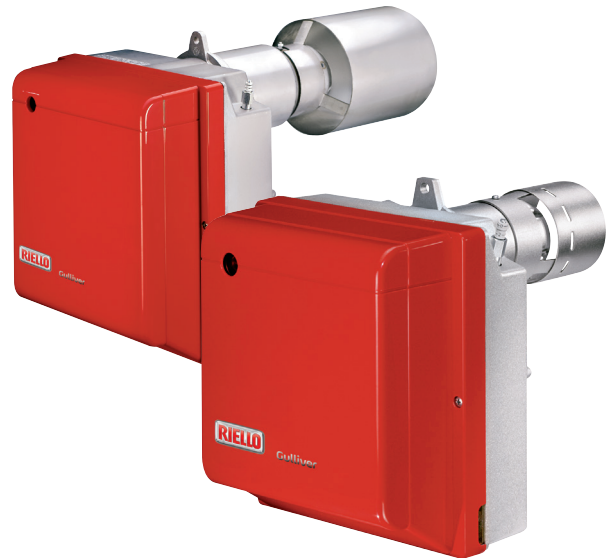

BG6.1D	53,8/65,8 ÷ 104	KW
BG7.1D	77,7/92 ÷ 149,5	KW

Guidelines for installation of burners in conformity to EU Regulation:

A RIELLO burner (Heat Generator), where it is matched with a water-based boiler (Heater Housing) with a nominal output ≤ 400 kW, providing heat for heating purposes and heat to deliver sanitary hot water, can be installed:

- With boilers (heater housings) already in service in the field, for replacement of identical products, in conformity to Article 1, paragraph 2, point (G) of the EU Regulation No. 813/2013;
- With boilers (heater housings) on a new installation.

FIRING RATES

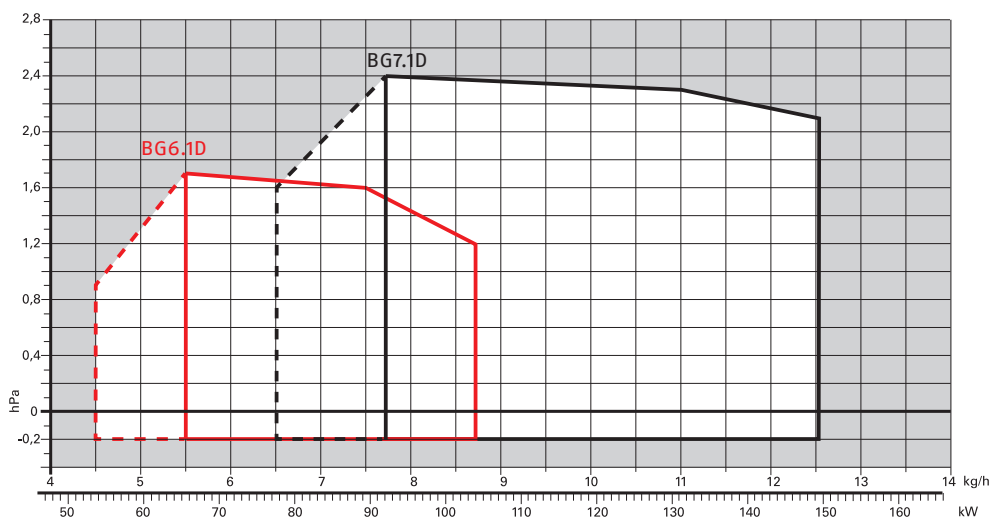

 Useful working field for choosing the burner

 1st stage operation range

Test conditions conforming to EN267
 Temperature: 20°C
 Pressure: 1013,5 mbar
 Altitude: 0 m a.s.l.

Low NOx Two Stage Light Oil Burners

GULLIVER BGD SERIES

Overall dimensions (mm)

BURNER

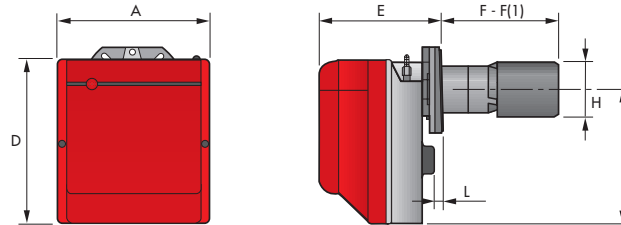

MODEL	A	D	E	F	F(1)	H	I	L
► BG6.1D	300	345	228	284	363	131	285	12
► BG7.1D	300	345	247	394	-	165	285	12

F1: length with extended combustion head

BURNER - BOILER MOUNTING FLANGE

BG6.1D

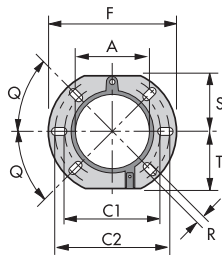

BG7.1D

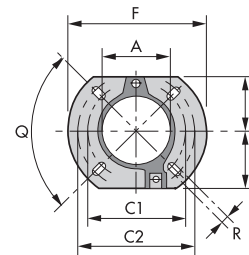

MODEL	A	C1	C2	F	Q	R	S	T
► BG6.1D	106	140	170	189	45°	11	83	83
► BG7.1D	127	160	190	213	90°	11	99	99

PACKAGING

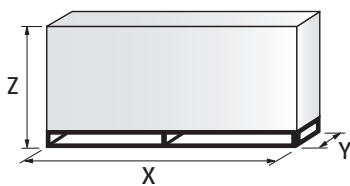

MODEL	X	Y	Z	kg
► BG6.1D	600	345	430	20
► BG7.1D	600	345	430	20

Specification

DESIGNATION OF SERIES

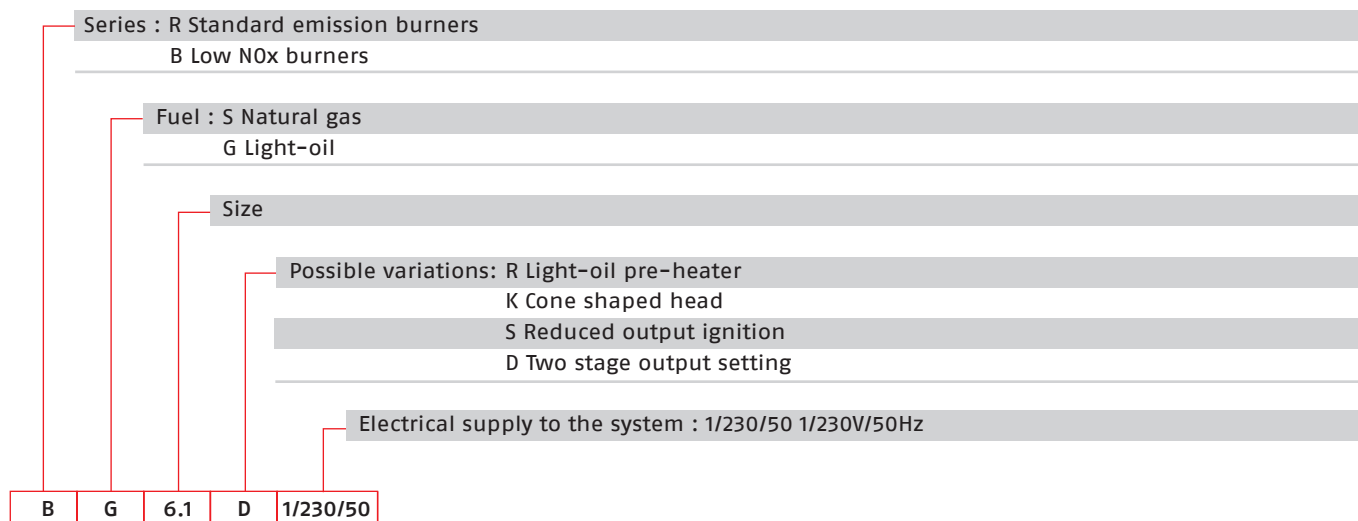

STATE OF SUPPLY

Completely automatic monobloc light oil burners, two stage operation, made up of:

- Fan with forward curve blades
- Cover lined with sound-proofing material
- Air damper completely closed in stand by
- Air damper, with 1st and 2nd stage adjustment (2nd stage adjustment without removing the casing)
- Single phase electric motor 230 V, 50 Hz
- Combustion head fitted with:
 - stainless steel head cone, resistant to high temperatures
 - ignition electrodes
 - flame stability disk
- Geared pump for fuel supply, fitted with:
 - filter
 - pressure regulator
 - attachments for fitting a pressure gauge and vacuum meter
 - internal by-pass for preparing for single-pipe installations
- Fuel feed solenoid valve incorporated in the pump
- IRD for flame detection
- Microprocessor-based burner safety control box M0 550, with diagnostic and remote control release functions
- Protection filter against radio interference (included into burner safety control box)
- Light oil nozzle
- IP X0D (IP 40) protection level.

Standard equipment:

- Two flexible pipes for connection to the light oil supply line
- Two nipples for connection to the pump
- Flange, screws and nuts for fixing
- Thermal screen
- 4-pin plug
- Instruction handbook for installation, use and maintenance
- Spare parts catalogue.

Low NOx Two Stage Light Oil Burners

GULLIVER BGD SERIES

Available models

CODE	MODEL	HEAT OUTPUT		TOTAL ELECTRICAL POWER (kW)	NOTE
		(kW)	(kg/h)		
20015693	BG6.1D 1/230/50	53,8/65,8 - 104	4,5/5,5 - 8,7	0,39	-
20015694	BG6.1D TL 1/230/50	53,8/65,8 - 104	4,5/5,5 - 8,7	0,39	-
20015696	BG7.1D 1/230/50	77,7/92 - 149,5	6,5/7,7 - 12,5	0,47	-

Net calorific value: 11,8 kWh/kg; 10200 kcal/kg - Viscosity at 20°C: 4÷6 mm²/s (cSt).
The burners of BGD series are in according to 2014/30/EU - 2014/35/EU - 2006/42 EC Directive and EN 267.

Burner accessories

Light oil filter



For cleaning light oil from dirty particles and impurities filters with the following features are available:

BURNER	FILTERING DEGREE (µm)	KIT CODE
► All models	60	3006561

Filter made up of aluminium body and stainless steel filtering cartridge; available singularly.

BURNER	FILTERING DEGREE (µm)	KIT CODE
► All models	60	3075011

Filter made up of aluminium cover, plastic tank and nylon filtering cartridge; available in packaging of 50 pieces.

Light oil filter/degassing unit



To solve problems of air or water in the oil circuit a special filter/degassing unit is available, made up of aluminium cover, plastic tank, stainless steel filtering cartridge, air release cap and water purge valve. It is available singularly.

BURNER	FILTERING DEGREE (µm)	KIT CODE
► All models	100	3000926

7-pin plug kit

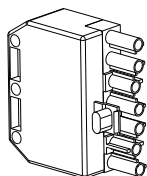

If necessary a 7-pin plug kit is available (in packaging of n. 5 pieces).

BURNER	KIT CODE
► All models	3000945

RL/1 BLU SERIES

The new RL/1 BLU series represents Riello's last step of innovation in terms of Low NOx technology applied to light oil burners.

The series includes one model, with an output ranging from 115 to 260 kW.

This new burner has been re-designed for use in hot or superheated water boilers, hot air, steam generators or diathermic oil boilers.

The burners are fitted with a microprocessor-based control panel, which supplies indication of burner status and fault causes.

A new, more compact and handable case has been designed, keeping overall dimensions compact in order to ensure an easier servicing and maintenance.

The elevated performance of the forward-blades fan, together with a new innovative combustion head, guarantee flexibility of use and excellent working at all firing rates always with Low NOx emissions.



RL 25/1 BLU

115 ÷ 260 kW

Guidelines for installation of burners in conformity to EU Regulation:

A RIELLO burner (Heat Generator), where it is matched with a water-based boiler (Heater Housing) with a nominal output ≤ 400 kW, providing heat for heating purposes and heat to deliver sanitary hot water, can be installed:

- With boilers (heater housings) already in service in the field, for replacement of identical products, in conformity to Article 1, paragraph 2, point (G) of the EU Regulation No. 813/2013;
- With boilers (heater housings) on a new installation.

FIRING RATES

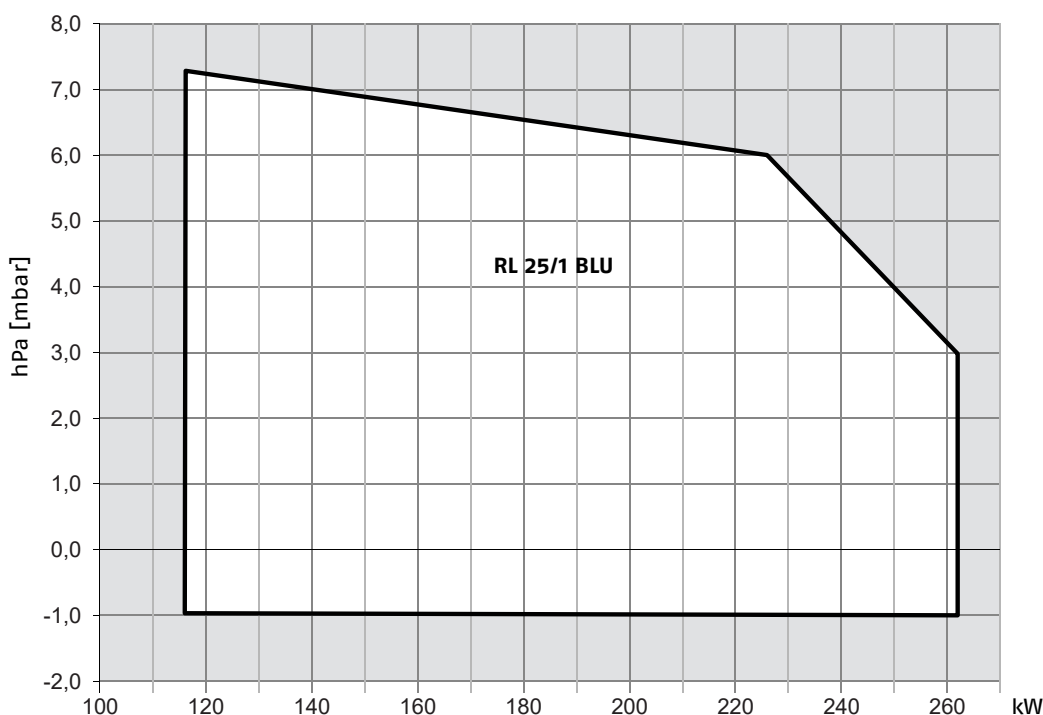

Useful working field for choosing the burner

Test conditions conforming to EN267
 Temperature: 20°C
 Pressure: 1013,5 mbar
 Altitude: 0 m a.s.l.

Low NOx One Stage Light Oil Burners

RL/1 BLU SERIES

Overall dimensions (mm)

BURNER

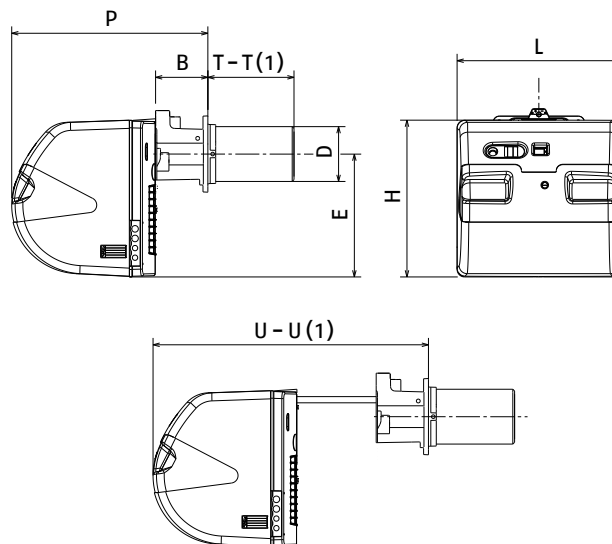

MODEL	B	D	E	L	H	P	U	T	T(1)	U(1)
► RL 25/1 BLU	130	140	305	442	416	508	788	200	280	788

BURNER - BOILER MOUNTING FLANGE

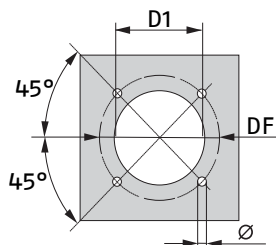

MODEL	D1	DF	Ø
► RL 25/1 BLU	160	224	M8

PACKAGING

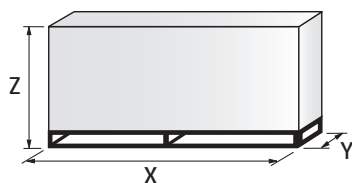

MODEL	X	Y	Z	kg
► RL 25/1 BLU	1190	492	510	40

RL/1 BLU SERIES

Specification

DESIGNATION OF SERIES

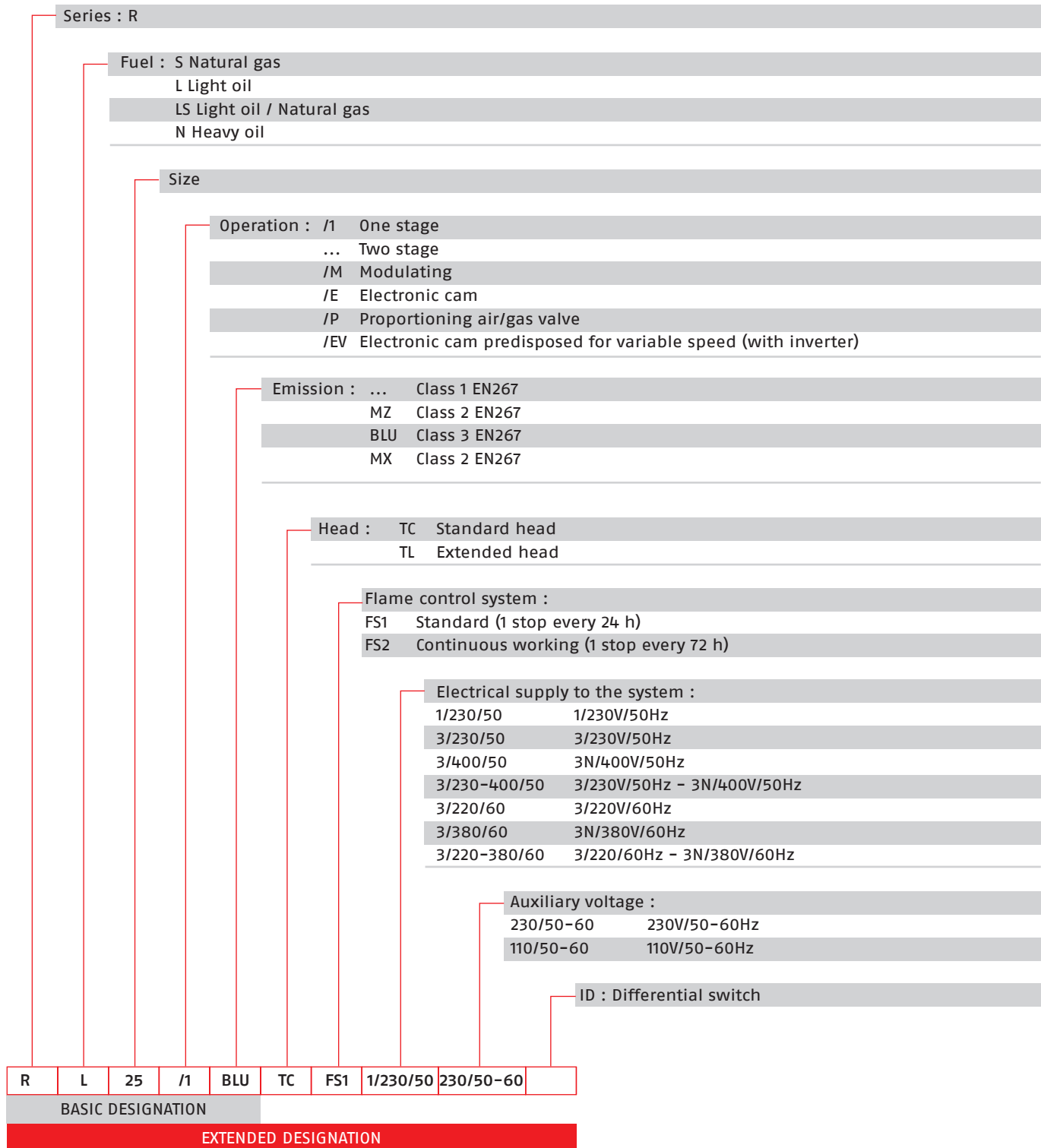

Low NOx One Stage Light Oil Burners

RL/1 BLU SERIES

Specification

STATE OF SUPPLY

Monoblock forced draught Low NOx oil burner with one stage operation, made up of:

- Air suction circuit lined with sound-proofing material
- High performance fan with forward blades
- New Low NOx combustion head technology
- Gears pump for high pressure fuel supply
- UV sensor for flame detection
- Microprocessor-based burner safety control box, with diagnostic function
- Burner on/off switch
- Flame inspection window
- Slide bars for easier installation and maintenance
- Protection filter against radio interference
- IP X0D (IP 40) electric protection level.

Standard equipment:

- 2 flexible pipes for connection to the oil supply network
- 2 gaskets for the flexible pipes
- 2 nipples for connection to the pump
- 1 thermal screen
- 4 screws for fixing the burner flange to the boiler
- Wiring loom fittings for electrical connections
- Instruction handbook for installation, use and maintenance
- Spare parts catalogue.

Available models

CODE	MODEL	HEAT OUTPUT		TOTAL ELECTRICAL POWER (kW)	NOTE
		(kW)	(kg/h)		
20156024	RL 25/1 BLU TC FS1 1/230/50 230/50-60	115 - 260	10 - 22	0,6	
20157095	RL 25/1 BLU TL FS1 1/230/50 230/50-60	115 - 260	10 - 22	0,6	

Net calorific value: 11,8 kWh/kg - 10200 kcal/kg - Viscosity at 20°C: 4-6 mm²/s (cSt)

The burners of RL/1 BLU series are in according to 2014/30/EU - 2014/35/EU - 2006/42 EC Directive and EN 267.

RL/1 BLU SERIES

Burner accessories

Nozzles



The nozzles of RL 25/1 BLU burners are chosen on the basis of the maximum output required from the application.

NOTE: each burner needs N° 1 nozzle.

GPH	RATED DELIVERY [kg/h] AT 8 bar	RATED DELIVERY [kg/h] AT 20 bar	DELAVAN 60°A CODE	MONARCH 60°PLP CODE
2.25	7.4	11.9	3042134	3041132
2.50	8.2	13.4	3042144	3041142
3.00	9.9	16.1	3042148	3041152
3.50	11.5	18.8	3042164	3041162
4.00	13.2	21.5	3042174	3041172
4.50	14.8	24.0	3042184	3041182
5.00	16.5	26.8	3042194	3041192
5.50	18.1	29.5	3042204	3041202
6.00	19.8	32.2	3042214	3041212

Sound proofing box

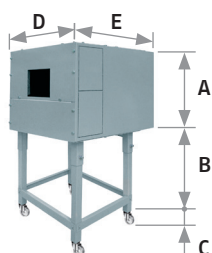

If noise emission needs reducing even further, sound-proofing boxes are available. When a lower "B" dimension is required, it is available the Box Support Kit code 20065135 which allows to reduce it at the fixed dimension of 55 mm. The sound-proofing boxes are not suitable for outdoor use.

BURNER	BOX TYPE	A (mm)	B (mm) min-max	C (mm)	D (mm)	E (mm)	[dB(A)] (*)	BOX CODE
► RL 25/1 BLU	C1/3	650	372 - 980	110	690	770	10	3010403

(*) Average noise reduction according to EN 15036-1 standard

Degasing unit



To solve problem of air in the oil sucked, a degasing unit are available.

BURNER	FILTER	FILTERING DEGREE (µm)	DEGASING UNIT CODE
► RL 25/1 BLU	With filter	50 - 75	3010055

Connection flange kit

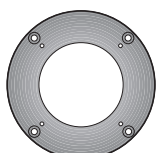

A kit is available for use where the burner opening on the boiler is of excessive diameter.

BURNER	(mm)	KIT CODE
► RL 25/1 BLU	170 (internal diameter) 300 (external diameter)	3010138

PC Interface kit



To connect the control box to a personal computer for the transmission of operation, fault signals and detailed service information, an interface adapter with PC software are available.

BURNER	KIT CODE
► RL 25/1 BLU	3002719

Low NOx One Stage Light Oil Burners

RL/1 BLU SERIES

Burner accessories

Volt free contact kit



A volt free contact kit is available for installation onto the burner. It can be used for a remote interface between burner operating signals. Every burner can be equipped with a single kit to remote the flame presence signal and the burner lockout indication.

BURNER	KIT CODE
▶ RL 25/1 BLU	3010419

Post-ventilation kit

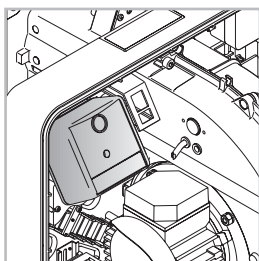

To have 20 s ventilation after opening of thermostats chain, a special kit is available.

BURNER	KIT CODE
▶ RL 25/1 BLU	3010453

Hours counter kit

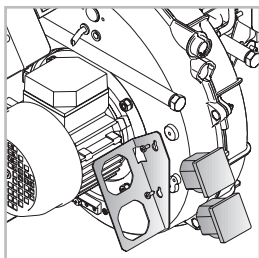

To measure the burner working time a hours counter kit is available.

BURNER	KIT CODE
▶ RL 25/1 BLU	3010450

Ground fault interrupter kit



A "Ground fault interrupter kit" is available as a safety device for electrical system fault.

BURNER	KIT CODE
▶ RL 25/1 BLU	3010448

Protection kit (electromagnetic interferences)

When the burner is installed in a room particularly subject to electromagnetic interference (signals emitted over 10 V/m) due for example to INVERTER presence or in systems where the lengths of the thermostat connections is over 20 meters, this specific protection kit is available as an interface between the thermostatic controls and the burner.

BURNER	KIT CODE
▶ RL 25/1 BLU	3010386

RL BLU SERIES

The new RL BLU series represents Riello's last step of innovation in terms of Low NOx technology applied to light oil burners.

The series includes three models, with an output ranging from 90 to 598 kW.

Those burners have been e-designed for use in hot or superheated water boilers, hot air, steam generators or diathermic oil boilers.

A servomotor with three adjustable positions guarantees correct air output and air damper closing when the burner is turned off.

The burners are fitted with a microprocessor-based control panel, which supplies indication of burner status and fault causes.

A new, more compact and handable case has been designed, keeping overall dimensions compact in order to ensure an easier servicing and maintenance.

The elevated performance of the forward-blades fan, together with a new innovative combustion head, guarantee flexibility of use and excellent working at all firing rates always with Low NOx emissions.



RL 25 BLU	90/115 ÷ 260 kW
RL 35 BLU	173/230 ÷ 355 kW
RL 42 BLU	191/323 ÷ 598 kW

Guidelines for installation of burners in conformity to EU Regulation:

A RIELLO burner (Heat Generator), where it is matched with a water-based boiler (Heater Housing) with a nominal output ≤ 400 kW, providing heat for heating purposes and heat to deliver sanitary hot water, can be installed:

- With boilers (heater housings) already in service in the field, for replacement of identical products, in conformity to Article 1, paragraph 2, point (G) of the EU Regulation No. 813/2013;
- With boilers (heater housings) on a new installation.

FIRING RATES

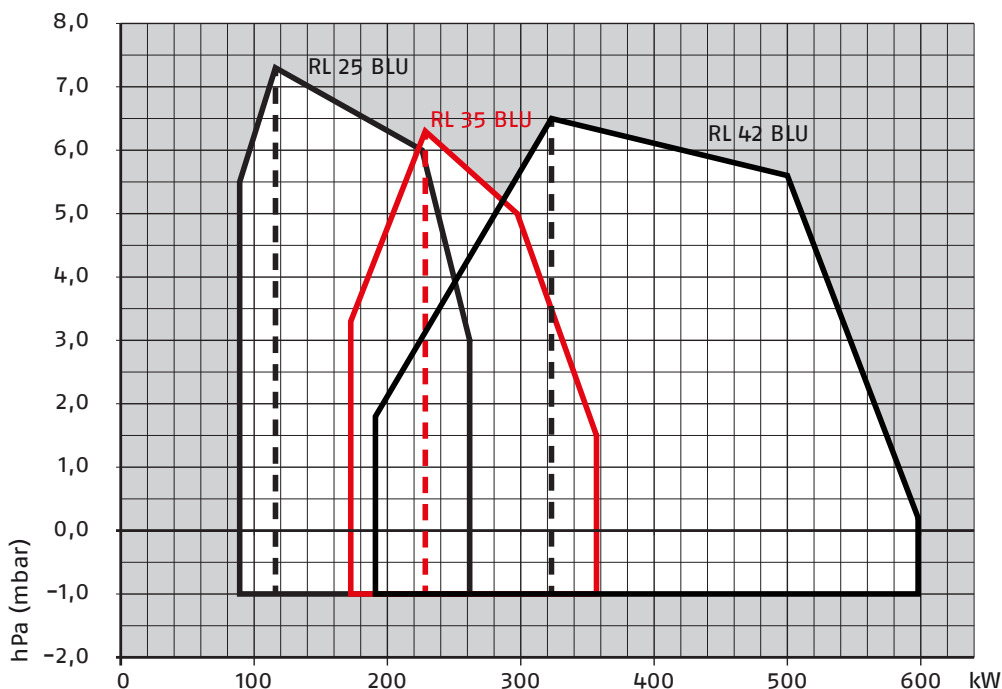

Useful working field for choosing the burner



1st stage operation range

Test conditions conforming to EN267
 Temperature: 20°C
 Pressure: 1013,5 mbar
 Altitude: 0 m a.s.l.

Low NOx Two Stage Light Oil Burners

RL BLU SERIES

Overall dimensions (mm)

BURNER

RL 25 BLU - RL 35 BLU

RL 42 BLU

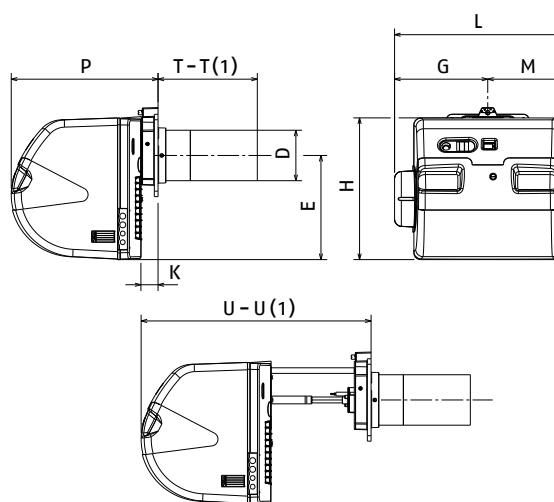
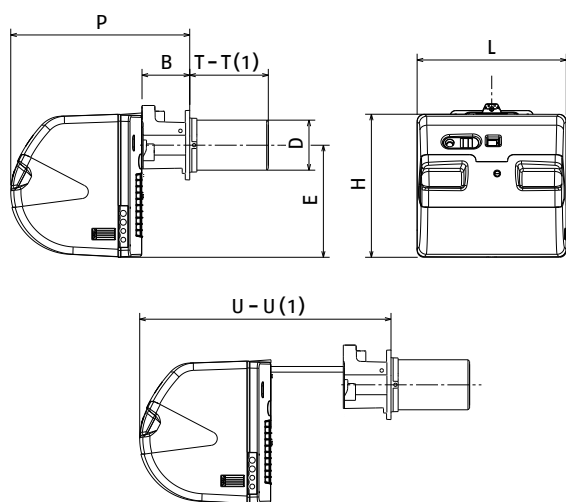

MODEL	B	D	E	G	K	L	M	H	P	T	T (1)	U (1)
▶ RL 25 BLU	130	140	305	-	-	442	-	416	508	200	280	788
▶ RL 35 BLU	130	140	305	-	-	442	-	416	508	218	298	788
▶ RL 42 BLU	-	163	335	300	60	533	238	490	680	291	430	80 - 815

BURNER - BOILER MOUNTING FLANGE

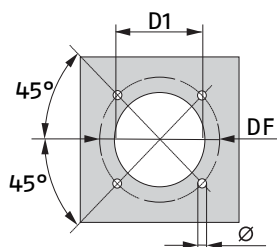

MODEL	D1	DF	Ø
▶ RL 25 BLU	160	224	M8
▶ RL 35 BLU	160	224	M8
▶ RL 42 BLU	185	275-325	M12

PACKAGING

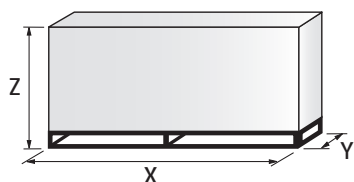

MODEL	X	Y	Z	kg
▶ RL 25 BLU	1190	510	492	40
▶ RL 35 BLU	1190	510	492	41
▶ RL 42 BLU	1200	560	520	42

RL BLU SERIES

Specification

DESIGNATION OF SERIES

Series : R										
Fuel : S Natural gas										
L Light oil										
LS Light oil / Natural gas										
N Heavy oil										
Size										
Operation : /1 One stage										
... Two stage										
/M Modulating										
/E Electronic cam										
/P Proportioning air/gas valve										
/EV Electronic cam predisposed for variable speed (with inverter)										
Emission : ... Class 1 EN267										
MZ Class 2 EN267										
BLU Class 3 EN267										
MX Class 2 EN267										
Head : TC Standard head										
TL Extended head										
Flame control system :										
FS1 Standard (1 stop every 24 h)										
FS2 Continuous working (1 stop every 72 h)										
Electrical supply to the system :										
1/230/50		1/230V/50Hz								
3/230/50		3/230V/50Hz								
3/400/50		3N/400V/50Hz								
3/230-400/50		3/230V/50Hz - 3N/400V/50Hz								
3/220/60		3/220V/60Hz								
3/380/60		3N/380V/60Hz								
3/220-380/60		3/220/60Hz - 3N/380V/60Hz								
Auxiliary voltage :										
230/50-60		230V/50-60Hz								
110/50-60		110V/50-60Hz								
ID : Differential switch										
R	L	25		BLU	TC	FS1	1/230/50	230/50-60		
BASIC DESIGNATION				EXTENDED DESIGNATION						

Low NOx Two Stage Light Oil Burners

RL BLU SERIES

Specification

STATE OF SUPPLY

Monoblock forced draught Low NOx oil burner with completely automatic two stage operation, made up of:

- Air suction circuit lined with sound-proofing material
- High performance fan with stright blades
- Air damper for air setting, driven by the adjustable servomotor
- New Low NOx combustion head technology
- Gears pump for high pressure fuel supply
- Two oil valves fitted directly on to the pump
- UV sensor for flame detection
- Microprocessor-based burner safety control box, with diagnostic function
- Burner on/off switch
- Manual high/low flame switch
- Flame inspection window
- Slide bars for easier installation and maintenance
- Protection filter against radio interference
- IP X0D (IP 40) electric protection level (RL 25-35 BLU)
- IP 44 electric protection level (RL 42 BLU).

Standard equipment:

- 2 flexible pipes for connection to the oil supply network
- 2 gaskets for the flexible pipes
- 2 nipples for connection to the pump
- 1 thermal screen
- 4 screws for fixing the burner flange to the boiler
- Wiring loom fittings for electrical connections
- Instruction handbook for installation, use and maintenance
- Spare parts catalogue.

Available models

CODE	MODEL				HEAT OUTPUT		TOTAL ELECTRICAL POWER (kW)	NOTE
					(kW)	(kg/h)		
20116089	RL 25 BLU	TC	FS1	1/230/50 230/50-60	90/115 - 260	8/10 - 22	0,6	
20156736	RL 25 BLU	TL	FS1	1/230/50 230/50-60	90/115 - 260	8/10 - 22	0,6	
20116062	RL 35 BLU	TC	FS1	1/230/50 230/50-60	173/230 - 355	15/19 - 30	0,6	
20156738	RL 35 BLU	TL	FS1	1/230/50 230/50-60	173/230 - 355	15/19 - 30	0,6	
20027567	RL 42 BLU	TC	FS1	3/230-400/50 230/50-60	191/323-598	16,1/27,2-50,6	1,4	

Net calorific value: 11,8 kWh/kg - 10200 kcal/kg - Viscosity at 20°C: 4-6 mm²/s (cSt)

The burners of RL BLU series are in according to 2014/30/EU - 2014/35/EU - 2006/42 EC Directive and EN 267.

RL BLU SERIES

Burner accessories

Nozzles



The nozzles of RL 25 - 35 and 42 BLU burners are chosen on the basis of the maximum output required from the application.

NOTE: each burner needs N° 1 nozzle.

RL 25-35 BLU

GPH	RATED DELIVERY [kg/h] AT 8 bar	RATED DELIVERY [kg/h] AT 20 bar	DELAVAN 60°A CODE	MONARCH 60°PLP CODE
2.25	7.4	11.9	3042134	3041132
2.50	8.2	13.4	3042144	3041142
3.00	9.9	16.1	3042148	3041152
3.50	11.5	18.8	3042164	3041162
4.00	13.2	21.5	3042174	3041172
4.50	14.8	24.0	3042184	3041182
5.00	16.5	26.8	3042194	3041192
5.50	18.1	29.5	3042204	3041202
6.00	19.8	32.2	3042214	3041212

RL 42 BLU

GPH	RATED DELIVERY [kg/h] AT 8 bar	RATED DELIVERY [kg/h] AT 20 bar	DELAVAN 45°A CODE
6.00	20.4	31.7	20011679
6.50	22.1	34.5	20024162
7.00	23.8	37.1	20024163
7.50	25.5	40.0	20024164
8.00	27.2	42.5	20024165
8.50	28.9	45.5	20024166
9.00	30.6	48.0	20024167
9.50	32.3	51.0	20024168
10.00	34.0	53.5	20024169

Extended head kit

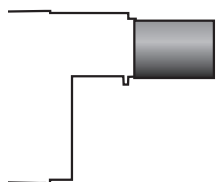

"Standard head" burners can be transformed into "extended head" versions, by using the special kit.

BURNER	STANDARD HEAD LENGTH (mm)	EXTENDED HEAD LENGTH (mm)	KIT CODE
► RL 42 BLU	295	430	20024155

Low NOx Two Stage Light Oil Burners

RL BLU SERIES

Burner accessories

Sound proofing box

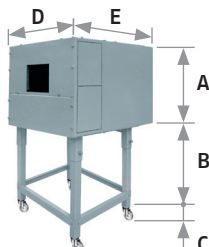

If noise emission needs reducing even further, sound-proofing boxes are available. When a lower "B" dimension is required, it is available the Box Support Kit code 20065135 which allows to reduce it at the fixed dimension of 55 mm. The sound-proofing boxes are not suitable for outdoor use.

BURNER	BOX TYPE	A (mm)	B (mm) min-max	C (mm)	D (mm)	E (mm)	[dB(A)] (*)	BOX CODE
▶ RL 25 BLU RL 35 BLU	C1/3	650	372 - 980	110	690	770	10	3010403
▶ RL 42 BLU	C4/5	850	160 - 980	110	980	930	10	3010404

(*) Average noise reduction according to EN 15036-1 standard

Degasing unit



To solve problem of air in the oil sucked, two versions of degasing unit are available.

BURNER	FILTER	FILTERING DEGREE (µm)	DEGASING UNIT CODE
▶ All models	With filter	50 - 75	3010055

Connection flange kit

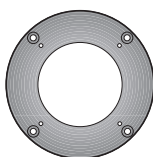

A kit is available for use where the burner opening on the boiler is of excessive diameter.

BURNER	(mm)	KIT CODE
▶ RL 25 BLU - RL 35 BLU	170 (internal diameter) 300 (external diameter)	3010138

PC Interface kit



To connect the control box to a personal computer for the transmission of operation, fault signals and detailed service information, an interface adapter with PC software are available.

BURNER	KIT CODE
▶ All models	3002719

Burner accessories

Volt free contact kit



A volt free contact kit is available for installation onto the burner. It can be used for a remote interface between burner operating signals. Every burner can be equipped with a single kit to remote the flame presence signal and the burner lockout indication.

BURNER	KIT CODE
► All models	3010419

Post-ventilation kit

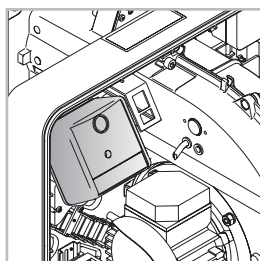

To have 20 s ventilation after opening of thermostats chain, a special kit is available.

BURNER	KIT CODE
► All models	3010453

Hours counter kit

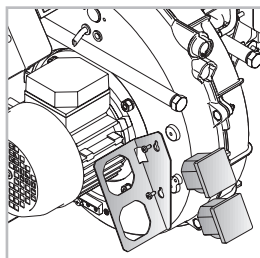

To measure the burner working time a hours counter kit is available.

BURNER	KIT CODE
► RL 25 BLU – RL 35 BLU	3010450

Ground fault interrupter kit



A "Ground fault interrupter kit" is available as a safety device for electrical system fault.

BURNER	KIT CODE
► All models	3010448

Protection kit (electromagnetic interferences)

When the burner is installed in a room particularly subject to electromagnetic interference (signals emitted over 10 V/m) due for example to INVERTER presence or in systems where the lengths of the thermostat connections is over 20 meters, this specific protection kit is available as an interface between the thermostatic controls and the burner.

BURNER	KIT CODE
► All models	3010386

RL/M BLU SERIES

The RL/M BLU burners series covers a firing range from 360 to 1023 kW, and it has been designed for use in hot or superheated water boilers, hot air or steam generators and diathermic oil boilers.

Operation can be "two stage progressive" or, alternatively, "modulating" with the installation of a PID logic regulator and respective probes.

RL/M BLU burners series guarantees high efficiency levels in all applications, thus reducing fuel consumption and running costs.

Sound emissions optimisation is guaranteed by the use of fans with reverse curve blades and sound deadening material incorporated in the air suction circuit.

The exclusive design ensures reduced dimensions, simple use and maintenance. A wide range of accessories guarantees elevated working flexibility.

Guidelines for installation of burners in conformity to EU Regulation:

A RIELLO burner (Heat Generator), where it is matched with a water-based boiler (Heater Housing) with a nominal output ≤ 400 kW, providing heat for heating purposes and heat to deliver sanitary hot water, can be installed:

- With boilers (heater housings) already in service in the field, for replacement of identical products, in conformity to Article 1, paragraph 2, point (G) of the EU Regulation No. 813/2013;
- With boilers (heater housings) on a new installation.



RL 55/M BLU	190/356 ÷	712 kW
RL 85/M BLU	223/594 ÷	1023 kW

FIRING RATES

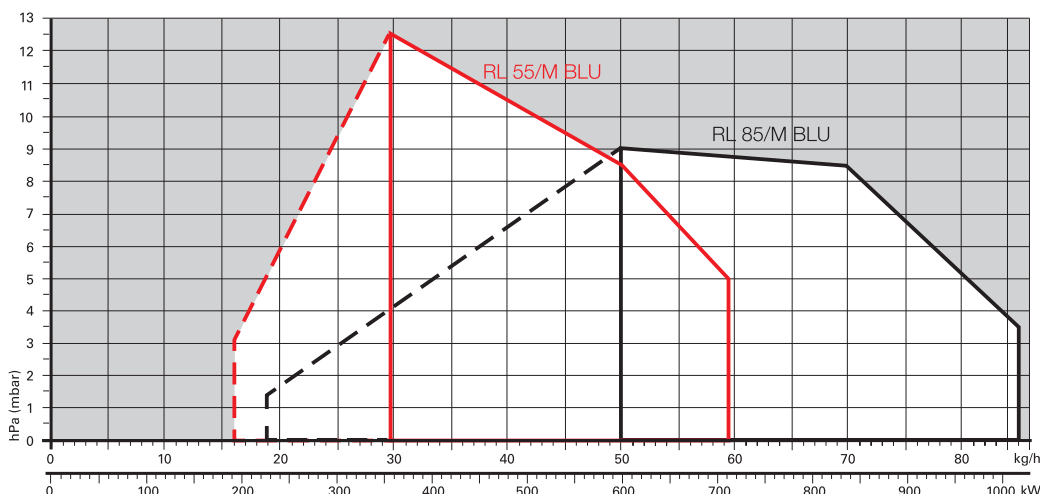

Useful working field for choosing the burner

Modulation range

Test conditions conforming to EN267
 Temperature: 20°C
 Pressure: 1013,5 mbar
 Altitude: 0 m a.s.l.

NOTE: The RL 55-85/M BLU burners are designed exclusively for combustion chambers with flue gas outlet from the bottom, for example three flue gas passes (not reverse flame boilers) accessible through the door. Maximum thickness of the frontal boiler wall: 250 mm.

Exhaust gases ducts must be always and exclusively directed upwards; change in directions must be realized only by bent elements; the angle between the axis of the stroke coming out of the combustion chamber and the axis of the chimney must be smaller than 45°.

Low NOx Modulating Light Oil Burners

RL/M BLU SERIES

Overall dimensions (mm)

BURNER

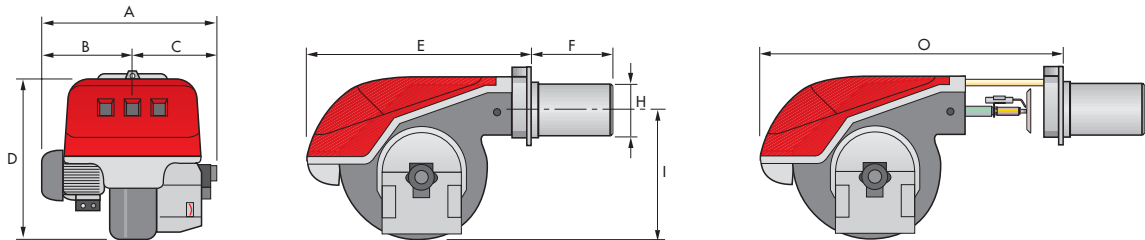

MODEL	A	B	C	D	E	F	H	I	O
▶ RL 55/M BLU	663	296	367	555	680	365	189	430	951
▶ RL 85/M BLU	705	338	367	555	680	365	189	430	951

BURNER - BOILER MOUNTING FLANGE

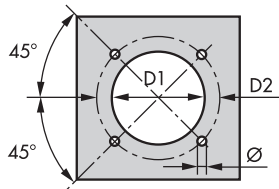

MODEL	D1	D2	Ø
▶ RL 55/M BLU	195	275-325	M12
▶ RL 85/M BLU	195	275-325	M12

PACKAGING

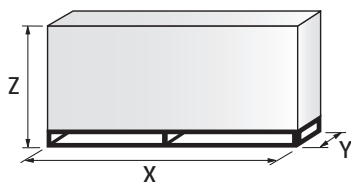

MODEL	X	Y	Z	kg
▶ RL 55/M BLU	1270	745	885	65
▶ RL 85/M BLU	1270	745	885	70

Specification

DESIGNATION OF SERIES

Series : R

Fuel : S Natural gas
L Light oil
LS Light oil / Natural gas
N Heavy oil

Size

Setting : /1 One stage
... Two stage
/M Modulating

Emission : ... Class 1 EN267
MZ Class 2 EN267
BLU Class 3 EN267
MX Class 2 EN267

Head : TC Standard head
TL Extended head

Flame control system :
FS1 Standard (1 stop every 24 h)
FS2 Continuous working (1 stop every 72 h)

Electrical supply to the system :

1/230/50	1/230V/50Hz
3/230/50	3/230V/50Hz
3/400/50	3N/400V/50Hz
3/230-400/50	3/230V/50Hz - 3N/400V/50Hz
3/220/60	3/220V/60Hz
3/380/60	3N/380V/60Hz
3/220-380/60	3/220V/60Hz - 3N/380V/60Hz

Auxiliary voltage :
230/50-60 230V/50-60Hz
110/50-60 110V/50-60Hz

ID : Differential switch

R	L	85	/M	BLU	TC	FS1	3/230-400/50	230/50-60	
---	---	----	----	-----	----	-----	--------------	-----------	--

BASIC DESIGNATION

EXTENDED DESIGNATION

Low NOx Modulating Light Oil Burners

RL/M BLU SERIES

Specification

STATE OF SUPPLY

Monoblock forced draught oil burner with two stage progressive or modulating setting, with a specific kit, fully automatic, made up of:

- air suction circuit lined with sound-proofing material
- fan with reverse curve blades high performance with low sound emissions
- air damper for air setting and automatic oil output regulator controlled by a servomotor with variable cam
- starting motor at 2800 rpm, three-phase 400V with neutral, 50Hz
- combustion head, that can be set on the basis of required output, fitted with:
 - stainless steel end cone, resistant to corrosion and high temperatures
 - ignition electrodes
 - flame stability disk
- gears pump for high pressure fuel supply, fitted with:
 - filter
 - pressure regulator
- connections for installing a pressure gauge and vacuumeter
- internal by-pass for single pipe installation
- valve unit with a double oil safety valve on the output circuit and safety valve on the return circuit; double safety valve on the return circuit
- safety oil pressure switch for stop the burner in case of problems in the return circuit
- photocell for flame detection
- burner safety control box, fitted with control function for the correct positioning of the servomotor and possibility of post-ventilation by just changing the electric wiring
- burner on/off switch
- flame inspection window
- manual or automatic output increase/decrease switch
- slide bars for easier installation and maintenance
- protection filter against radio interference
- IP 44 electric protection level.

Standard equipment:

- 2 flexible pipes for connection to the oil supply network
- 2 gaskets for the flexible pipes
- 2 nipples for connection to the pump
- 4 screws for fixing the burner flange to the boiler
- 1 thermal screen
- wiring loom fittings for electrical connections
- instruction handbook for installation, use and maintenance
- spare parts catalogue.

Available models

CODE	MODEL	HEAT OUTPUT		TOTAL ELECTRICAL POWER (kW)	NOTE
		(kW)	(kg/h)		
20169228	RL 55/M BLU TC FS1 3/230-400/50 230/50-60	190/356-712	16/30-60	2,2	(1)
20169230	RL 85/M BLU TC FS1 3/230-400/50 230/50-60	223/594-1023	18,8/50-86,2	2,6	(1)

Other versions, with FS2 (continuous working), are available on request.

(1) with RFGO control box

Net calorific value: 11,8 kWh/kg - 10200 kcal/kg - Viscosity at 20°C: 4-6 mm²/s (cSt)

The burners of RL/M BLU series are in according to 2014/30/EU - 2014/35/EU - 2006/42 EC Directive and EN 267.

Due to the improvement applied on the technical specification of some products, some burner codes will change during year 2019. The table below summarizes the correspondence between the previous and the new code.

MODEL			NEW CODE		OLD CODE
RL 55/M BLU	TC	FS1 3/230-400/50 230/50-60	20169228	(1)	3899210
RL 85/M BLU	TC	FS1 3/230-400/50 230/50-60	20169230	(1)	3896011

Burner accessories

Nozzles type A3 60°

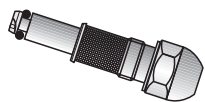

The return nozzles must be ordered separately. The following table shows the features and codes on the basis of the maximum required fuel output.

BURNER	RATED DELIVERY (kg/h) (*)	NOZZLE CODE
▶ RL 55-85/M BLU	30	3009867
	40	3009868
	50	3009869
	60	3009870
	90	3009871
	80	3009872

(*) Nozzle rated delivery is referred to atomised pressure

Spacer kit



If burner head penetration into the combustion chamber needs reducing, varying thickness spacers are available, as given in the following table:

BURNER	SPACER THICKNESS S (mm)	KIT CODE
▶ RL 55-85/M BLU	135	3010129

Sound proofing box

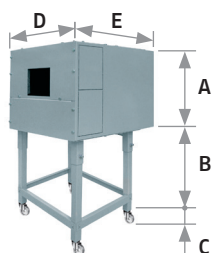

If noise emission needs reducing even further, sound-proofing boxes are available. When a lower "B" dimension is required, it is available the Box Support Kit code 20065135 which allows to reduce it at the fixed dimension of 55 mm. The sound-proofing boxes are not suitable for outdoor use.

BURNER	BOX TYPE	A (mm)	B (mm) min-max	C (mm)	D (mm)	E (mm)	[dB(A)] (*)	BOX CODE
▶ RL 55/M BLU RL 85/M BLU	C4/5	850	160 - 980	110	980	930	10	3010404

(*) Average noise reduction according to EN 15036-1 standard

Degasing unit



To solve problem of air in the oil sucked, two versions of degasing unit are available.

BURNER	FILTER	FILTERING DEGREE (µm)	DEGASING UNIT CODE
▶ RL 55-85/M BLU	With filter	50 - 75	3010055

NOTE: For burner deliveries higher than 80 kg/h, install two parallel degasing units.

Low NOx Modulating Light Oil Burners

RL/M BLU SERIES

Burner accessories

Accessories for modulating operation



To obtain modulating operation, the RL/M BLU series of burners requires a regulator with three point outlet controls. The following table lists the accessories for modulating operation with their application range. For remote setpoint use RWF 55.

BURNER	REGULATOR TYPE	REGULATOR CODE
▶ RL 55-85/M BLU	RWF 50.2	20082208
	RWF 55.5	20099657



The relative temperature or pressure probes fitted to the regulator must be chosen on the basis of the application.

BURNER	PROBE TYPE	RANGE (°C) (bar)	PROBE CODE
▶ RL/M BLU	Temperature PT 100	-100 ÷ 500°C	3010110
▶ RL/M BLU	Pressure 4 ÷ 20 mA	0 ÷ 2,5 bar	3010213
▶ RL/M BLU	Pressure 4 ÷ 20 mA	0 ÷ 16 bar	3010214

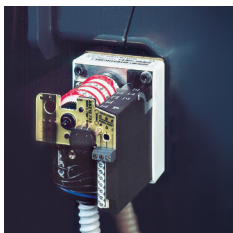

Depending on the servomotor fitted to the burner, a three-pole potentiometer (1000 Ω) can be installed to check the position of the servomotor. The KITS available for the various burners are listed below.

BURNER	POTENTIOMETER KIT CODE
▶ RL 55-85/M BLU	3010021

RDB SERIES

The Riello RDB series of one stage light oil and kerosene burners is available in eleven basic models, with an output ranging from 16,8 to 120 kW, in three different structures. The models are available in light oil and kerosene versions, conventional flue and balanced flue, with or without the fuel pre-heater fitted.

A new model has been specifically designed to meet the increasing trends towards high pressure working field demand. These models are distinguished by their compact size. All the models use the same components designed by Riello for the RDB series. The high quality level guarantees safe working. The RDB burners are equipped with a geared pump suitable for Kerosene, Low Sulphur Kerosene and ultra low sulphur diesel oil (ULSD).

In developing these burners, special attention was paid to reducing noise, to the ease of installation and adjustment, to obtaining the smallest size possible to fit into any sort of boiler available on the market. All the models are approved by the EN 267 European Standard and conform to European Directives for EMC, Low Voltage, Machinery and Boiler Efficiency. All the RDB burners are fired before leaving the factory.

Guidelines for installation of burners in conformity to EU Regulation:

A RIELLO burner (Heat Generator), where it is matched with a water-based boiler (Heater Housing) with a nominal output ≤ 400 kW, providing heat for heating purposes and heat to deliver sanitary hot water, can be installed:

- With boilers (heater housings) already in service in the field, for replacement of identical products, in conformity to Article 1, paragraph 2, point (G) of the EU Regulation No. 813/2013;
- With boilers (heater housings) on a new installation.

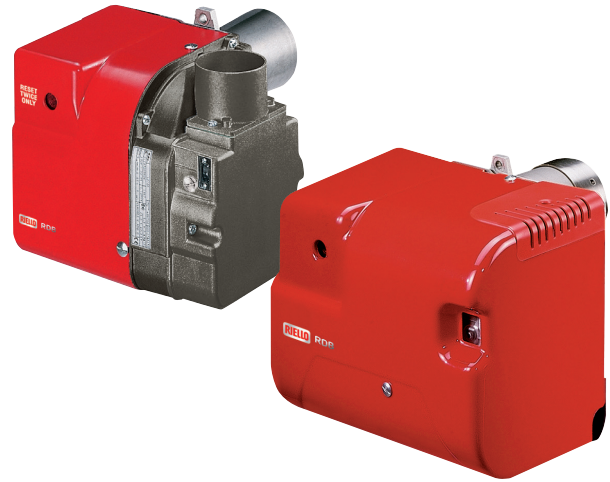

LIGHT OIL

RDB1-1R	16,8 ÷ 40,6 kW
RDB2-2R	24 ÷ 46,2 kW
RDB2.2 GKD	20 ÷ 43,5 kW
RDB2.1-2.1R	21 ÷ 54 kW
RDB2.2-2.2R	21 ÷ 54 kW
RDB3	35,6 ÷ 69 kW
RDB3.2	41,5 ÷ 119 kW
RDB4	47,45 ÷ 120 kW

FIRING RATES

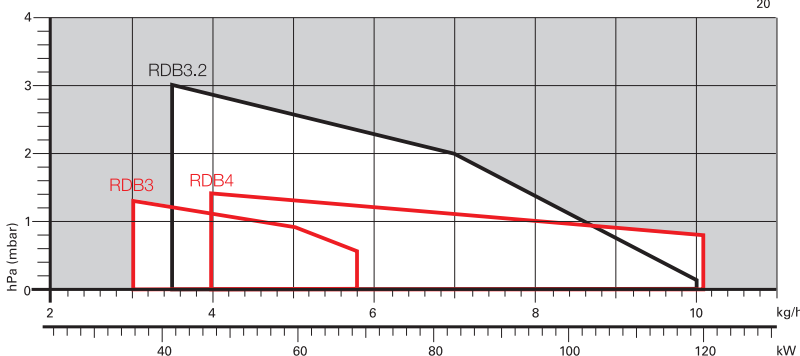
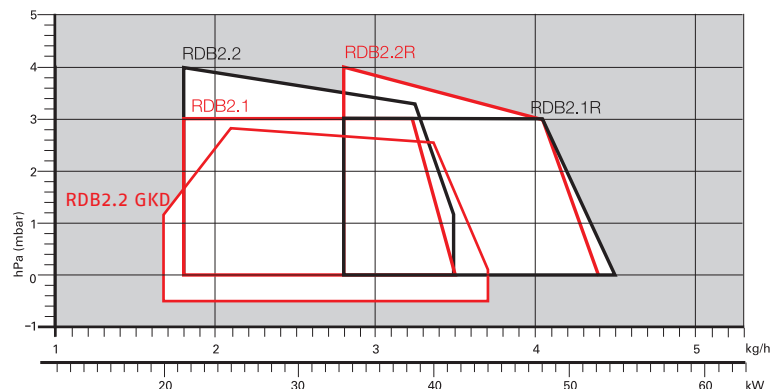
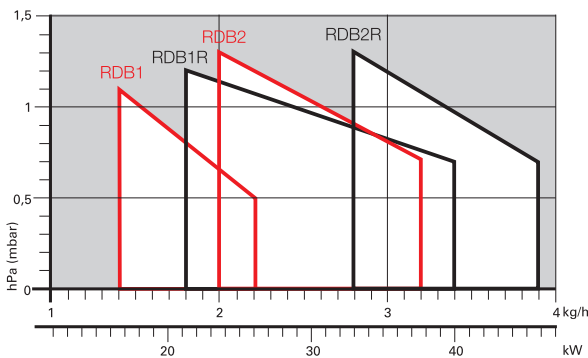

 Useful working field for choosing the burner

Test conditions conforming to EN267
 Temperature: 20°C
 Pressure: 1013,5 mbar
 Altitude: 0 m a.s.l.

One Stage Light Oil and Kerosene Burners

RDB SERIES

Overall dimensions (mm)

BURNER

RDB1-1R – RDB2-2R – RDB2.1-2.1R – RDB2.2-2.2R – RDB2.2 GKD

RDB3 – RDB3.2 – RDB4

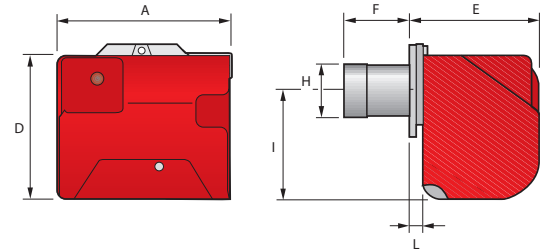
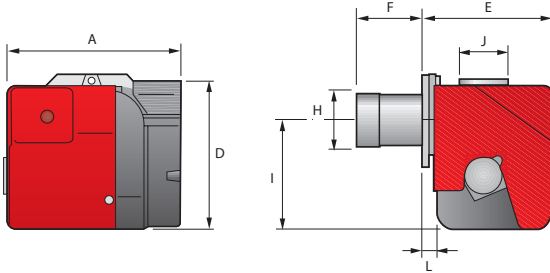

MODEL	A	D	H	F	E	L	I	J
▶ RDB1-1R	276	230	89-90	76-86	202	20	168	75
▶ RDB2-2R	276	230	89-90	76-86	202	20	168	75
▶ RDB2.1-2.1R	286	230	85	77	202	20	168	75
▶ RDB2.2-2.2R	286	230	85	77	202	20	168	75
▶ RDB2.2 GKD	286	232	103	203	200	18	171	75
▶ RDB3	325	268	88	78	253	30	204	75
▶ RDB3.2	325	268	95	69,5	253	30	204	75
▶ RDB4	325	268	105	111	253	30	204	75

BURNER - BOILER MOUNTING FLANGE

RDB1-1R – RDB2-2R – RDB2.1-2.1R – RDB2.2-2.2R – RDB2.2 GKD

RDB3 – RDB3.2 – RDB4

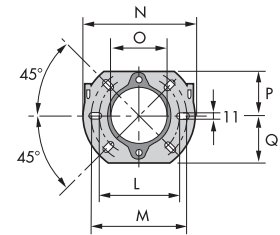
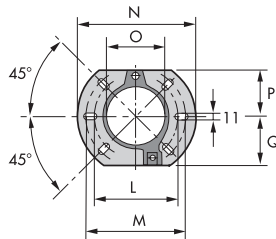

MODEL	L	M	N	O	P	Q
▶ RDB1-1R	130	150	180	91	72	72
▶ RDB2-2R	130	150	180	91	72	72
▶ RDB2.1-2.1R	130	150	180	91	72	72
▶ RDB2.2-2.2R-2.2 GKD	130	150	180	91	72	72
▶ RDB3	140	168	189	106	83	83
▶ RDB3.2	140	168	189	106	83	83
▶ RDB4	140	168	189	106	83	83

PACKAGING

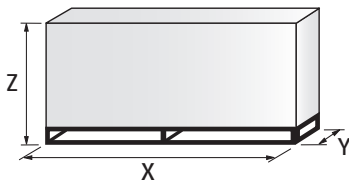

MODEL	X	Y	Z	kg
▶ RDB1-1R	395	305	295	11
▶ RDB2-2R	395	305	295	11
▶ RDB2.1-2.1R	395	305	295	11
▶ RDB2.2-2.2R-2.2 GKD	395	305	295	11
▶ RDB3	435	360	355	15
▶ RDB3.2	435	360	355	15
▶ RDB4	435	360	355	15

RDB SERIES

Specification

DESIGNATION OF SERIES

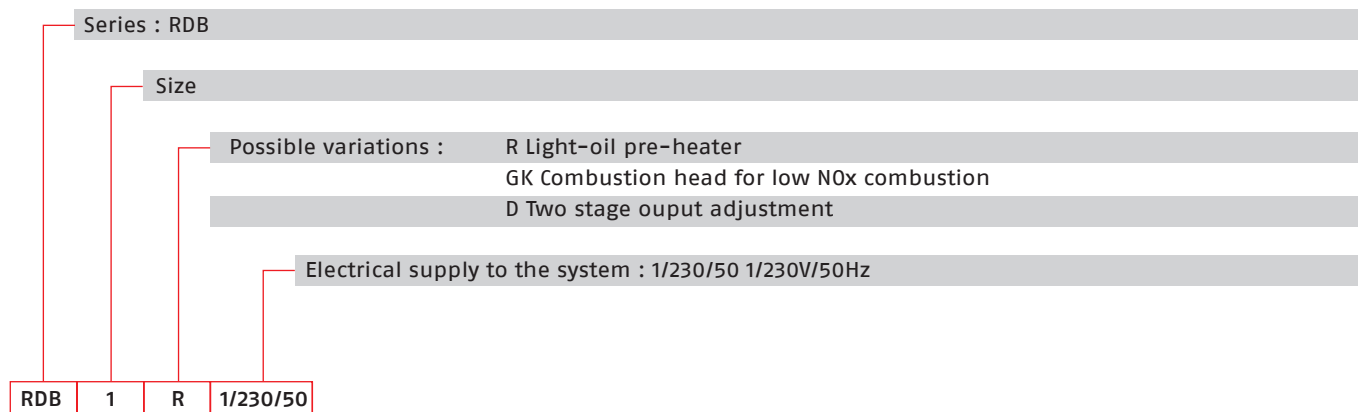

STATE OF SUPPLY

Completely automatic monobloc light oil and kerosene burners, one stage operation, made up of:

- Fan with forward inclined blades
- Air damper with external adjustment, with no need to remove the cover
- Air-tight air circuit, also available in the balanced flue version
- Single phase electric motor 230 V, 50 Hz
- Combustion head fitted with:
 - stainless steel head cone, resistant to high temperatures
 - ignition electrodes
 - flame stability disk
- Geared pump (specific version for kerosene) for fuel supply, fitted with filter
 - pressure regulator
 - attachments for fitting a pressure gauge and vacuum meter
 - internal by-pass for preparing for single-pipe installations
- Fuel feed solenoid valve incorporated in the pump
- Photocell for flame detection
- Electronic flame control equipment available with MO 535 (on demand)
- Light oil nozzle
- IP X0D (IP 40) protection level
- Fuel pre-heater (optional).

Standard equipment:

- Two flexible pipes for connection to the light oil supply line
- Two nipples for connection to the pump
- Flange, screws and nuts for fixing
- Thermal screen
- Air intake protection grill exagonal key
- Instruction handbook for installation, use and maintenance
- Spare parts list.

One Stage Light Oil and Kerosene Burners

RDB SERIES

Available models

CODE	MODEL	HEAT OUTPUT		TOTAL ELECTRICAL POWER	NOTE	
		(kW)	(kg/h)	(kW)		
(A)	RDB1	1/230/50	16,8 - 26,3	1,4 - 2,2	0,115	(1) (2)
(A)	RDB1R	1/230/50	21,6 - 40,6	1,8 - 3,4	0,170	(1)
(A)	RDB2	1/230/50	24 - 38,3	2 - 3,2	0,125	(1)
(A)	RDB2	1/230/50	29,6 - 59,3	2,5 - 5	0,125	(1)
(A)	RDB2R	1/230/50	33,2 - 46,2	2,8 - 3,9	0,175	(1)
(A)	RDB2.1	1/230/50	21,5 - 42	1,8 - 3,5	0,160	(1)
(A)	RDB2.1R	1/230/50	33 - 54	2,8 - 4,5	0,230	(1)
(A)	RDB2.2	1/230/50	21 - 41,5	1,8 - 3,5	0,160	(1)
(A)	RDB2.2R	1/230/50	33,5 - 51	2,9 - 4,3	0,230	(1)
(A)	RDB2.2 GKD	1/230/50	20 - 26	1,73 - 2,2	0,180	(1)
(A)	RDB3	1/230/50	35,6 - 68,7	3 - 5,8	0,160	(1)
(A)	RDB3.2	1/230/50	41 - 120	3,5 - 10	0,160	(1)
(A)	RDB4	1/230/50	47,45 - 120	4 - 10	0,160	(1)

(1) All burner models are OEM's customized.

(2) This code is unprovided with thermal screen.

Net calorific value: 11,8 kWh/kg; 10200 kcal/kg - Viscosity at 20°C: light oil models 4÷6; kerosene models 1,5÷6 mm²/s (cSt).

The burners of RDB series are in according to 2014/30/EU - 2014/35/EU - 2006/42 EC Directive and EN 267.

(A) Please contact Riello Burners Commercial and Technical Department, our Application Engineers will be pleased to help you.

RDB SERIES

Burner accessories

Balanced-conventional flue conversion kit



All the RDB series models are easily converted from conventional flue to balanced flue, by replacing the plastic screen on the air intake with the connector for the air supply pipe.

BURNER	BALANCED FLUE KIT CODE	CONVENTIONAL FLUE KIT CODE
▶ RDB1-1R - RDB2-2R - RDB2.1-2.1R - RDB2.2-2.2R - RDB2.2 GKD	3062774	3062775
▶ RDB3 - RDB4	3062774	3062876

Light oil filter



For cleaning light oil from dirty particles and impurities filters with the following features are available:

BURNER	FILTERING DEGREE (µm)	KIT CODE
▶ All models	60	3006561

Filter made up of aluminium body and stainless steel filtering cartridge; available singularly.

BURNER	FILTERING DEGREE (µm)	KIT CODE
▶ All models	60	3075011

Filter made up of aluminium cover, plastic tank and nylon filtering cartridge; available in packaging of 50 pieces.

Light oil filter/degassing unit



To solve problems of air or water in the oil circuit a special filter/degassing unit is available, made up of aluminium cover, plastic tank, stainless steel filtering cartridge, air release cap and water purge valve. It is available singularly.

BURNER	FILTERING DEGREE (µm)	KIT CODE
▶ All models	100	3000926

RC SERIES

Riello RC2-R is synonymous with highly compact size. The new burners in the light oil series are one stage with an output ranging from 17 to 46 kW. These burners have been specifically designed to meet the increasing trends towards direct connection to outside air for combustion and high pressure working field demand.

They are also flexible enough to suit both conventional and balanced flue versions, only changing the plastic screen to the snorkel in the air intake. These burners come with or without the cover. This designed marks Riello entry into many applications in the market which require both high performance and compact size. All RC2-R burners are fired before leaving the factory.

Guidelines for installation of burners in conformity to EU Regulation:

A RIELLO burner (Heat Generator), where it is matched with a water-based boiler (Heater Housing) with a nominal output ≤ 400 kW, providing heat for heating purposes and heat to deliver sanitary hot water, can be installed:

- With boilers (heater housings) already in service in the field, for replacement of identical products, in conformity to Article 1, paragraph 2, point (G) of the EU Regulation No. 813/2013;
- With boilers (heater housings) on a new installation.



RC2-26R	17 ÷ 26 kW
RC2-38R	24 ÷ 38 kW
RC2-46R	33 ÷ 46 kW
RC2.1-46R	33 ÷ 46 kW

FIRING RATES

Without baffle plate for BF/CF version

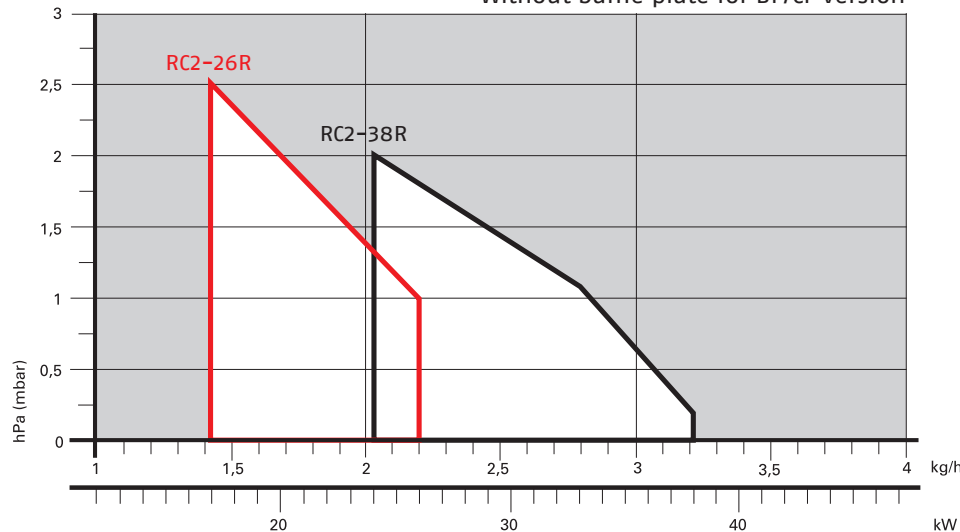

Useful working field for choosing the burner

Test conditions conforming to EN267
 Temperature: 20°C
 Pressure: 1013,5 mbar
 Altitude: 0 m a.s.l.

With baffle plate for BF/CF version

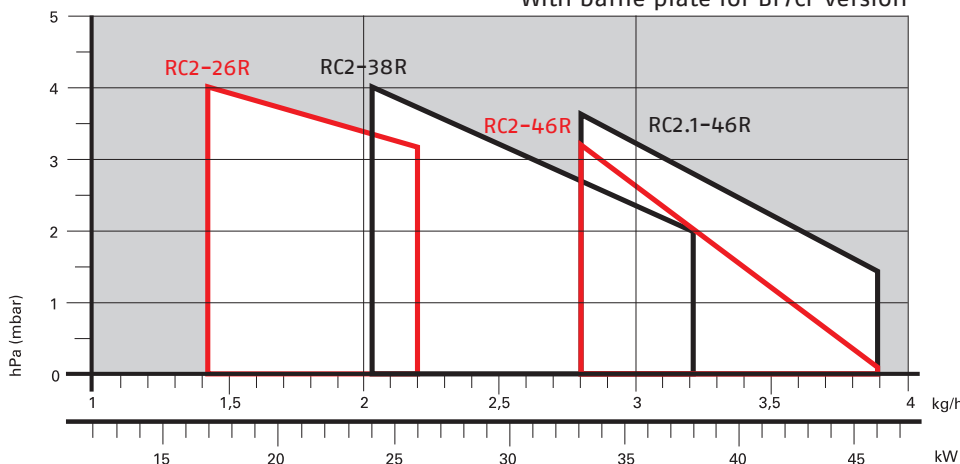

One Stage Light Oil Burners

RC SERIES

Overall dimensions (mm)

BURNER

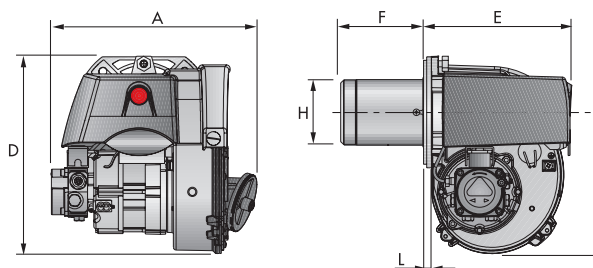

Model	A	D	E	F	H	I	L
▶ RC2-26R	267	256	192	109	85	183	10
▶ RC2-38	267	256	192	109	85	183	10
▶ RC2-38R	267	256	192	109	85	183	10
▶ RC2-46R	267	256	192	109	85	183	10
▶ RC2.1-46	267	256	192	109-177	85	183	10
▶ RC2.1-46R	267	256	192	109	85	183	10

BURNER - BOILER MOUNTING FLANGE

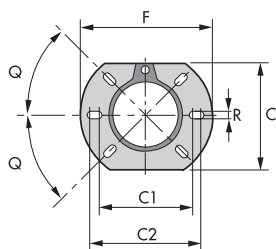

Model	C	C1	C2	F	Q	R
▶ RC2-26R	144	130	150	180	45°	11
▶ RC2-38	144	130	150	180	45°	11
▶ RC2-38R	144	130	150	180	45°	11
▶ RC2-46R	144	130	150	180	45°	11
▶ RC2.1-46	144	130	150	180	45°	11
▶ RC2.1-46R	144	130	150	180	45°	11

PACKAGING

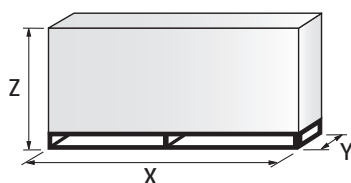

Model	X	Y	Z	kg
▶ RC2-26R	363	295	310	10
▶ RC2-38	363	295	310	10
▶ RC2-38R	363	295	310	10
▶ RC2-46R	363	295	310	10
▶ RC2.1-46	363	295	310	10
▶ RC2.1-46R	363	295	310	10

RC SERIES

Specification

DESIGNATION OF SERIES

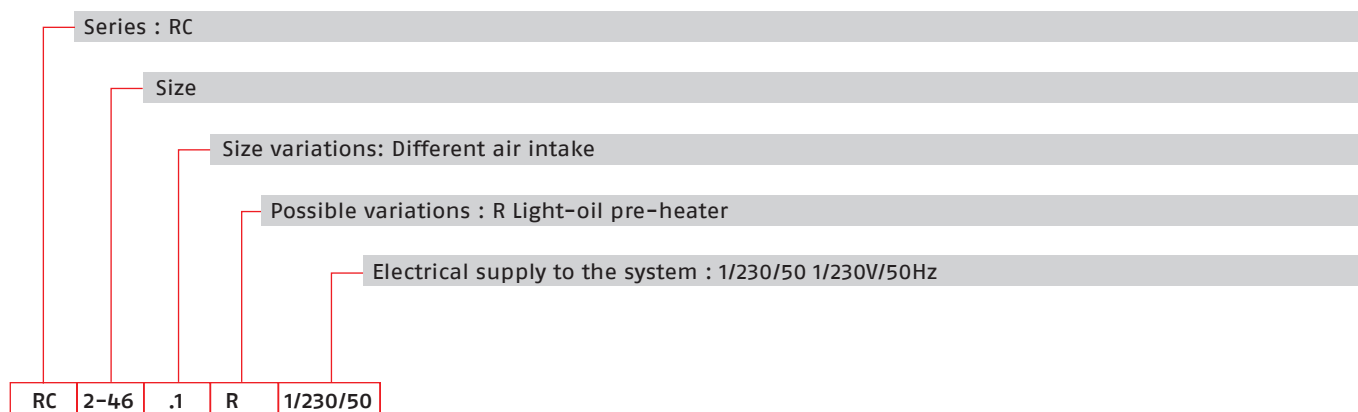

STATE OF SUPPLY

Completely automatic monobloc light oil burners, with single stage operation made up of:

- Forward blades fan and airtight fan house for high performance
- Air damper with adjustment for conventional flue version
- Single phase electric motor 230 V, 50 Hz
- Combustion head made up of:
 - stainless steel end cone resistant to high temperatures
 - ignition electrodes
 - flame stability disk
- Geared pump for fuel supply, fitted with:
 - filter
 - pressure regulator
 - connectors for installing a pressure gauge and vacuumeter
 - inner by-pass for preparing for single pipe installation
- Fuel feed solenoid incorporated in the pump
- Photocell for flame detection
- Electronic flame control equipment
- IP X0D (IP 40) protection level.

Standard equipment:

- Two flexible pipes and two connectors
- Flange, screen screws and nuts for fixing
- Cable with 6-pole socket
- Instruction handbook for installation, use and maintenance
- Spare parts catalogue.

One Stage Light Oil Burners

RC SERIES

Available models

CODE	MODEL		HEAT OUTPUT		TOTAL ELECTRICAL POWER (kW)	NOTE
			(kW)	(kg/h)		
On demand	RC2-26R	1/230/50	17 - 26	1,4 - 2,2	0,150	
On demand	RC2-38R	1/230/50	24 - 38	2,0 - 3,2	0,150	
On demand	RC2-38	1/230/50	24 - 38	2,0 - 3,2	0,150	
On demand	RC2-46R	1/230/50	33 - 46	2,8 - 3,9	0,150	
On demand	RC2.1-46	1/230/50	33 - 46	2,8 - 3,9	0,150	

Net calorific value: 11,8 kWh/kg; 10200 kcal/kg - Viscosity at 20°C: 4±6 mm²/s (cSt).
 The burners of RC series are in according to 2014/30/EU - 2014/35/EU - 2006/42 EC Directive and EN 267.

Burner accessories

Light oil filter



For cleaning light oil from dirty particles and impurities filters with the following features are available:

BURNER	FILTERING DEGREE (µm)	KIT CODE
► All models	60	3006561

Filter made up of aluminium body and stainless steel filtering cartridge; available singularly.

BURNER	FILTERING DEGREE (µm)	KIT CODE
► All models	60	3075011

Filter made up of aluminium cover, plastic tank and nylon filtering cartridge; available in packaging of 50 pieces.

Light oil filter/degassing unit



To solve problems of air or water in the oil circuit a special filter/degassing unit is available, made up of aluminium cover, plastic tank, stainless steel filtering cartridge, air release cap and water purge valve. It is available singularly.

BURNER	FILTERING DEGREE (µm)	KIT CODE
► All models	100	3000926

Balanced flue conversion kit



The RC2-R models are easily converted from conventional flue to balanced flue version, by replacing the plastic air intake with the connector for the air supply pipe.

BURNER	KIT CODE
► RC2-26R/38R/46R	3002721
► RC2.1-46R	3020132

Hour counter kit for 530 SE and 531 SE control boxes



To measure the burner working time a hour counter kit is available.

BURNER	KIT CODE
► All models	3000904

GULLIVER RG SERIES

The Riello Gulliver RG one stage light oil burners series, is a complete range of products developed to respond to any request for home heating. The Gulliver RG series is available in ten different models, with an output ranging from 16,6 to 309,5 kW, divided in five different structures.

All the models use the same components designed by Riello for the Gulliver series. The high quality level guarantees safe working.

In developing these burners, special attention was paid to reducing noise, to the easiness of installation and adjustment, to obtaining the smallest size possible to fit into any sort of boiler available on the market.

All the models are approved by the EN 267 European Standard and conform to European Directives for EMC, Low Voltage, Machinery and Boiler Efficiency.

All the Gulliver RG burners are fired before leaving the factory.

Guidelines for installation of burners in conformity to EU Regulation:

A RIELLO burner (Heat Generator), where it is matched with a water-based boiler (Heater Housing) with a nominal output ≤ 400 kW, providing heat for heating purposes and heat to deliver sanitary hot water, can be installed:

- With boilers (heater housings) already in service in the field, for replacement of identical products, in conformity to Article 1, paragraph 2, point (G) of the EU Regulation No. 813/2013;
- With boilers (heater housings) on a new installation.

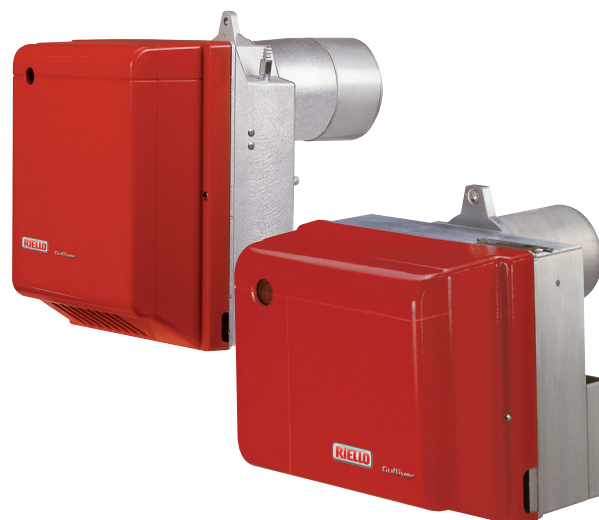

RG0.R	16,6 ÷ 27,3 kW
RG0.1	22,5 ÷ 35,6 kW
RG0.1R	21,3 ÷ 36,7 kW
RG1	32,0 ÷ 60,0 kW
RG1R	20,0 ÷ 60,0 kW
RG1RK	15,0 ÷ 60,0 kW
RG2	47,0 ÷ 119,0 kW
RG3	83,0 ÷ 178,0 kW
RG4S	118,5 ÷ 237,0 kW
RG5S	160,0 ÷ 309,5 kW

FIRING RATES

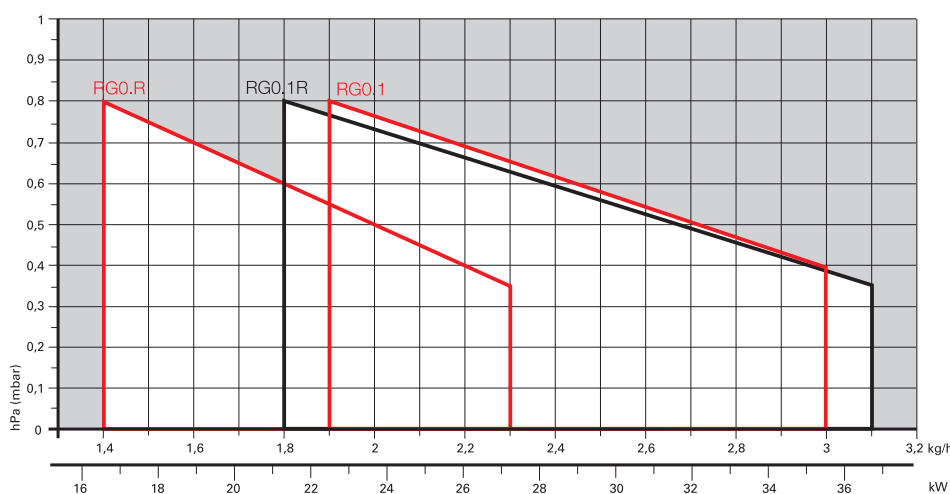

Useful working field for choosing the burner

Test conditions conforming to EN267
 Temperature: 20°C
 Pressure: 1013,5 mbar
 Altitude: 0 m a.s.l.

One Stage Light Oil Burners

GULLIVER RG SERIES

FIRING RATES

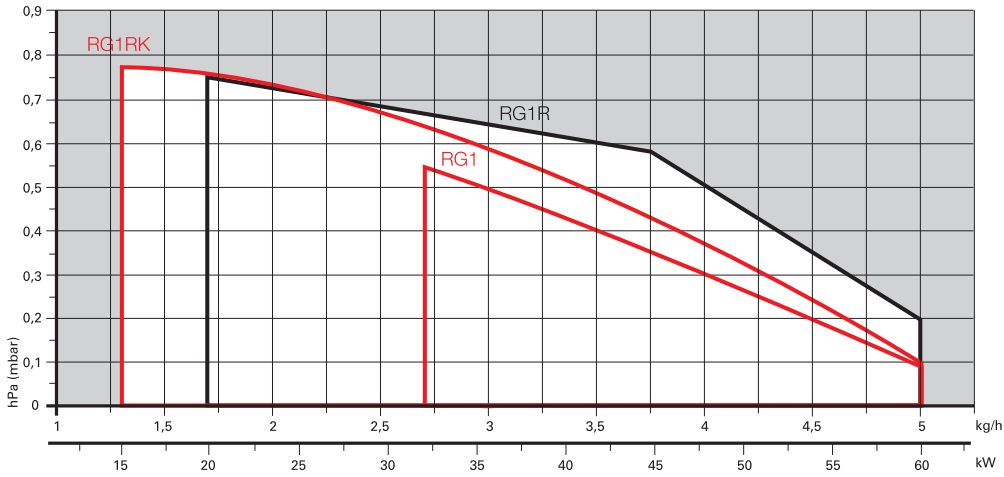

□ Useful working field for choosing the burner

Test conditions conforming to EN267
 Temperature: 20°C
 Pressure: 1013,5 mbar
 Altitude: 0 m a.s.l.

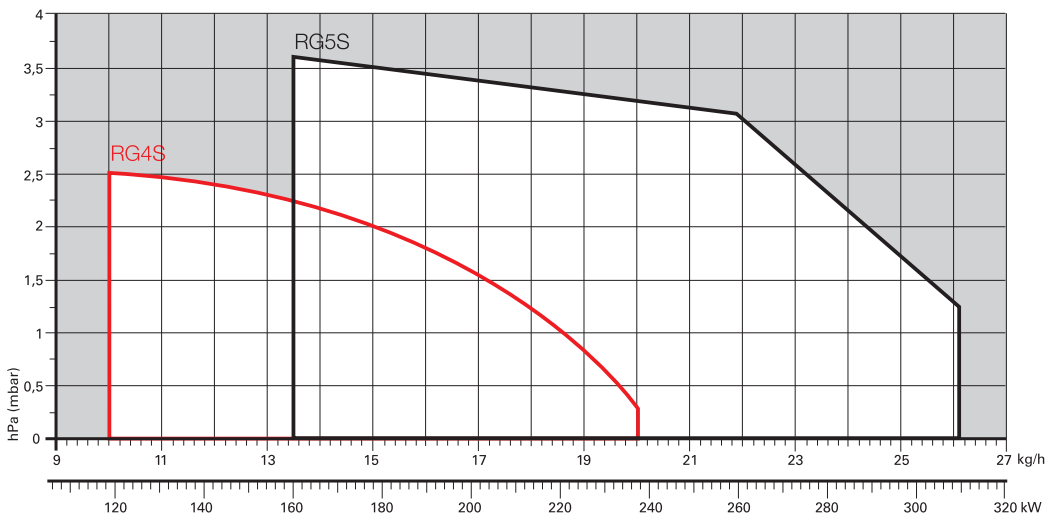
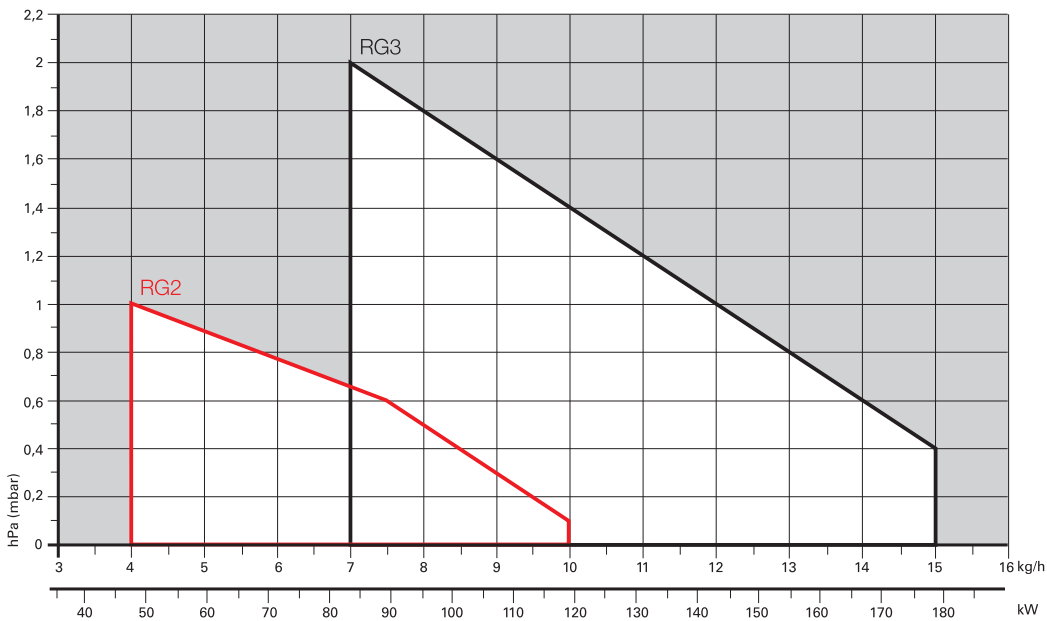

Overall dimensions (mm)

BURNER

GULLIVER RG0

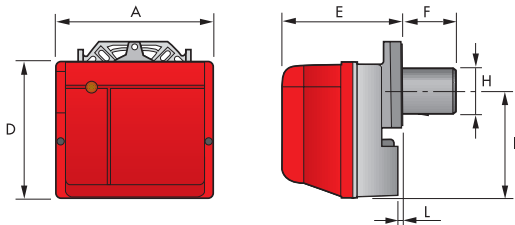

GULLIVER RG

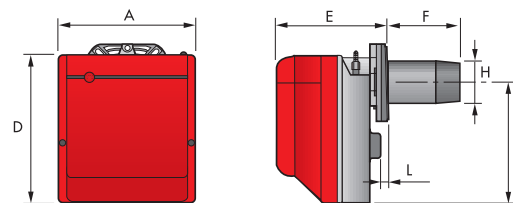

MODEL	A	D	E	F	H	I	L
▶ RG0.R	255	210	205	93	84	168	5
▶ RG0.1R	255	210	205	93	84	168	5
▶ RG0.1	255	210	205	93	84	168	5
▶ RG1	234	254	196	93	84	210	4
▶ RG1R	234	254	196	93	84	210	4
▶ RG1RK	234	254	196	111	84	210	4
▶ RG2	255	280	202	115 - 180	95	230	10
▶ RG3	300	345	228	142 - 300	123	285	12
▶ RG4S	300	345	228	142 - 212	123	285	12
▶ RG5S	300	345	247	155 - 395	125	285	12,5

BURNER - BOILER MOUNTING FLANGE

RG0.R - RG0.1R - RG0.1
RG1 - RG1R - RG1RK - RG2

RG3 - RG4S
RG5S

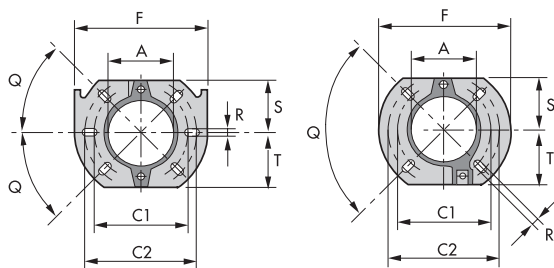

MODEL	A	C1	C2	F	Q	R	S	T
▶ RG0.R - RG0.1R - RG0.1 RG1 RG1R - RG1RK	91	130	150	180	45°	11	72	72
▶ RG2	106	140	168	189	45°	11	83	83
▶ RG3 - RG4S - RG5S	127	160	190	213	90°	11	99	99

PACKAGING

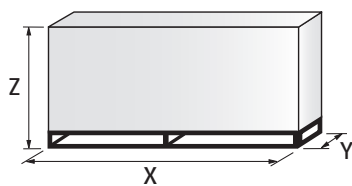

MODEL	X	Y	Z	kg
▶ RG0.R	358	300	300	9
▶ RG0.1R	358	300	300	9
▶ RG0.1	358	300	300	11
▶ RG1	353	278	320	13
▶ RG1R	353	278	320	13
▶ RG1RK	353	278	320	13
▶ RG2	363	298	350	13
▶ RG3	430	345	430	15
▶ RG4S	430	345	430	18
▶ RG5S	510	345	430	18

One Stage Light Oil Burners

GULLIVER RG SERIES

Specification

DESIGNATION OF SERIES

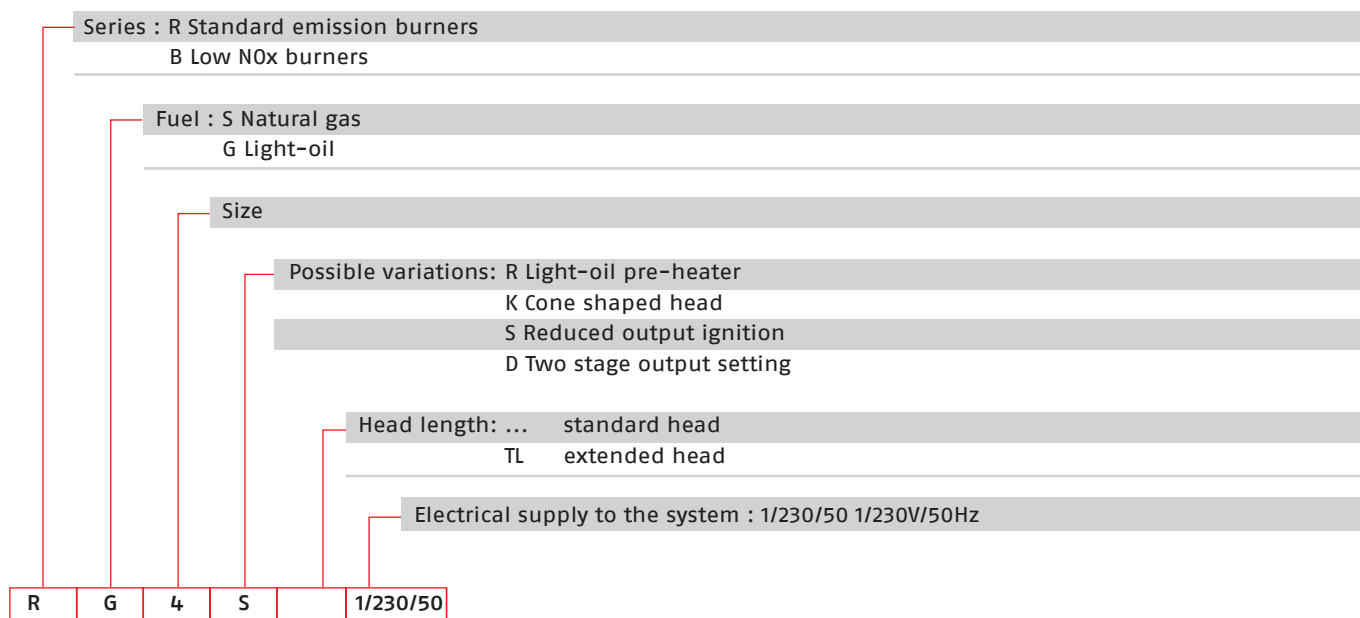

STATE OF SUPPLY

Completely automatic monobloc light oil burners, one stage operation, made up of:

- Fan with forward curve blades
- Cover lined with sound-proofing material
- Air damper, completely closed in stand by, with external adjustment, without need to remove the cover
- Single phase electric motor 230 V, 50 Hz
- Combustion head fitted with:
 - stainless steel head cone, resistant to high temperatures
 - ignition electrodes
 - flame stability disk
- Geared pump for fuel supply, fitted with:
 - filter
 - pressure regulator
 - attachments for fitting a pressure gauge and vacuum meter
 - internal by-pass for preparing for single-pipe installations
- Fuel feed solenoid valve incorporated in the pump
- Photocell for flame detection
- Electronic flame control equipment
- Light oil nozzle
- IP X0D (IP 40) protection level
- PTC fuel pre-heater (optional)
- Reduced output ignition mechanism (optional).

Standard equipment:

- Two flexible pipes for connection to the light oil supply line
- Two nipples for connection to the pump
- Flange, screws and nuts for fixing
- Thermal screen
- 7-pin plug (not included in models with digital control box M0 550)
- Instruction handbook for installation, use and maintenance
- Spare parts catalogue.

Available models

CODE	MODEL	HEAT OUTPUT		TOTAL ELECTRICAL POWER (kW)	NOTE
		(kW)	(kg/h)		

MODELS WITH ANALOGIC CONTROL BOX

3736550	RG0.R	1/230/50	16,6 - 27,3	1,4 - 2,3	0,290	
3736850	RG0.1	1/230/50	22,5 - 35,6	1,9 - 3,0	0,170	
3736750	RG0.1R	1/230/50	21,3 - 36,7	1,8 - 3,1	0,290	
3736350	RG1	1/230/50	32 - 60	2,7 - 5	0,170	
3736450	RG1R	1/230/50	20 - 60	1,7 - 5	0,290	
3736250	RG1RK	1/230/50	15 - 60	1,3 - 5	0,290	
3737750	RG2	1/230/50	47 - 119	4 - 10	0,180	
20052619	RG2 TL	1/230/50	47 - 119	4 - 10	0,180	
3739350	RG3	1/230/50	83 - 178	7 - 15	0,390	
20052621	RG3 TL	1/230/50	83 - 178	7 - 15	0,390	
20066327	RG3 TL	1/230/50	83 - 178	7 - 15	0,390	
3739650	RG4S	1/230/50	118,5 - 237	10 - 20	0,390	
20052623	RG4S TL	1/230/50	118,5 - 237	10 - 20	0,390	
3739950	RG5S	1/230/50	160 - 309,5	13,5 - 26,1	0,470	
20052625	RG5S TL	1/230/50	160 - 309,5	13,5 - 26,1	0,470	

MODELS WITH DIGITAL CONTROL BOX MO 550

3736554	RG0.R	1/230/50	16,6 - 27,3	1,4 - 2,3	0,290	
3736254	RG1RK	1/230/50	15 - 60	1,3 - 5	0,290	
3737754	RG2	1/230/50	47 - 119	4 - 10	0,180	
3739354	RG3	1/230/50	83 - 178	7 - 15	0,390	
3739654	RG4S	1/230/50	118.5 - 237	10 - 20	0,390	

Net calorific value: 11,8 kWh/kg; 10200 kcal/kg - Viscosity at 20°C: 4÷6 mm²/s (cSt).

The burners of RG series are in according to 2014/30/EU - 2014/35/EU - 2006/42 EC Directive and EN 267.

On demand all RG burners can be supplied with digital control box MO 550.

Bio fuels

Riello Burners is able to offer technical variants which allow burners to be used within environmental heating, process or special applications. These applications now include solutions for liquid Bio fuels (i.e. biodiesel and vegetable oil). Our experience in research and development and field applications with organic origin Bio fuels has resulted in Riello being able to offer a wide range of solutions for the combustion of Bio fuels.

One Stage Light Oil Burners

GULLIVER RG SERIES

Burner accessories

Extended head kit

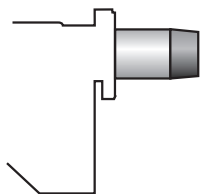

Kits of extended heads are available.

BURNER	STANDARD HEAD LENGTH (mm)	EXTENDED HEAD LENGTH (mm)	KIT CODE
▶ RG1 – RG1R	93	163	3000963
▶ RG1RK	111	181	3000982
▶ RG2	115	180	3000964
▶ RG2	115	300	3000967
▶ RG3	142	210	3000965
▶ RG3	142	300	3000968
▶ RG4S	142	210	3000966
▶ RG4S	142	300	3000969
▶ RG5S	155	300	3001068

Spacer kit

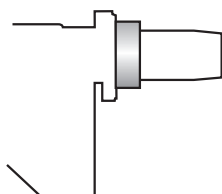

By using the special accessories, the burner can be with-drawn to reduce head penetration into the combustion chamber.

BURNER	SPACER THICKNESS S (mm)	KIT CODE
▶ RG0.R – RG0.1R – RG0.1 – RG1 – RG1R – RG1RK	15	3007931
▶ RG2	25	3000672
▶ RG3 – RG4S – RG5S	15	20103452

Pre-heater kit

This kit is used only for Gulliver RG1 burner. It can be installed in particular weather conditions and with viscous oil.

BURNER	KIT CODE
▶ RG1	3001083

Burner accessories

Light oil filter



For cleaning light oil from dirty particles and impurities filters with the following features are available:

BURNER	FILTERING DEGREE (µm)	KIT CODE
► All models	60	3006561

Filter made up of aluminium body and stainless steel filtering cartridge; available singularly.

BURNER	FILTERING DEGREE (µm)	KIT CODE
► All models	60	3075011

Filter made up of aluminium cover, plastic tank and nylon filtering cartridge; available in packaging of 50 pieces.

Light oil filter/degassing unit



To solve problems of air or water in the oil circuit a special filter/degassing unit is available, made up of aluminium cover, plastic tank, stainless steel filtering cartridge, air release cap and water purge valve. It is available singularly.

BURNER	FILTERING DEGREE (µm)	KIT CODE
► All models	100	3000926

7-pin plug kit

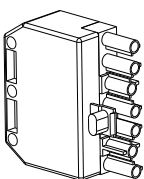

If necessary a 7-pin plug kit is available (in packaging of n. 5 pieces).

BURNER	KIT CODE
► All models	3000945

GULLIVER RGD SERIES

The Riello Gulliver RGD series of two stage light oil burners, is a complete range of products developed to respond to any request for home heating. The Gulliver RGD series is available in five different models, with an output ranging from 14 to 296 kW, divided in four different structures.

All the models use the same components designed by Riello for the Gulliver series. The high quality level guarantees safe working.

In developing these burners, special attention was paid to reducing noise, to the ease of installation and adjustment, to obtaining the smallest size possible to fit into any sort of boiler available on the market.

The two stage operation guarantees high level of thermal unit efficiency.

All the models are approved by the EN 267 European Standard and conform to European Directives for EMC, Low Voltage, Machinery and Boiler Efficiency.

All the Gulliver RGD burners are fired before leaving the factory.

Guidelines for installation of burners in conformity to EU Regulation:

A RIELLO burner (Heat Generator), where it is matched with a water-based boiler (Heater Housing) with a nominal output ≤ 400 kW, providing heat for heating purposes and heat to deliver sanitary hot water, can be installed:

- With boilers (heater housings) already in service in the field, for replacement of identical products, in conformity to Article 1, paragraph 2, point (G) of the EU Regulation No. 813/2013;
- With boilers (heater housings) on a new installation.



RG1RKD	14/17 ÷ 60 kW
RG2D	42/49 ÷ 118 kW
RG3D	65/83 ÷ 178 kW
RG4D	106/130 ÷ 237 kW
RG5D	95/142 ÷ 296 kW

Two Stage Light Oil Burners

GULLIVER RGD SERIES

FIRING RATES

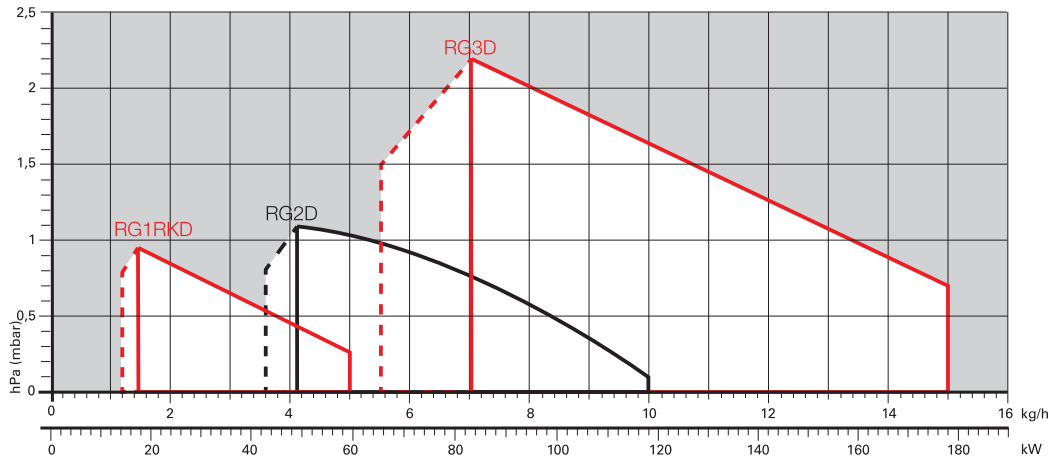

Useful working field for choosing the burner

1st stage operation range

Test conditions conforming to EN267
 Temperature: 20°C
 Pressure: 1013,5 mbar
 Altitude: 0 m a.s.l.

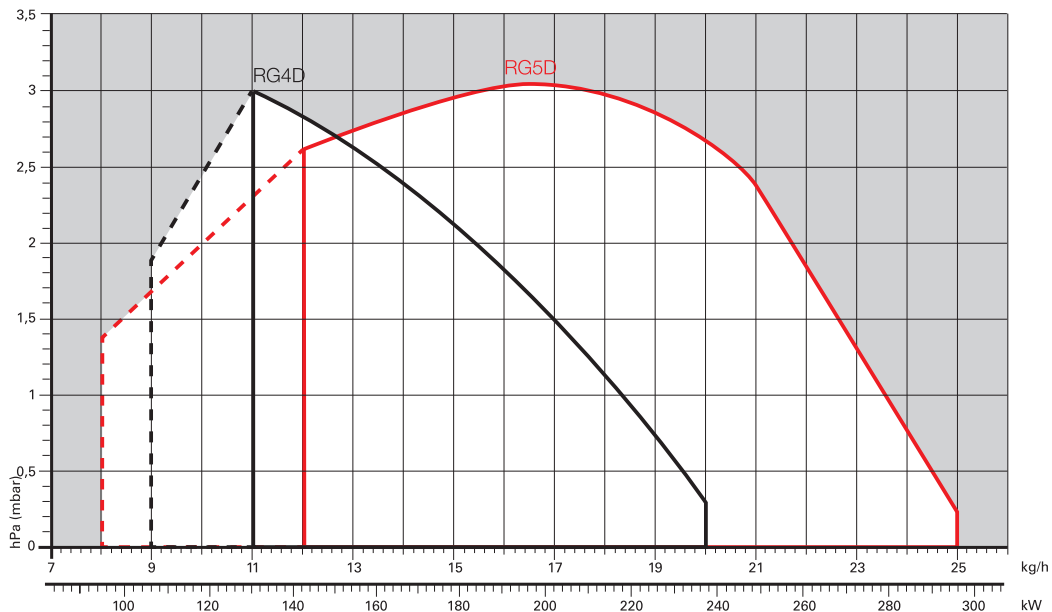

Overall dimensions (mm)

BURNER

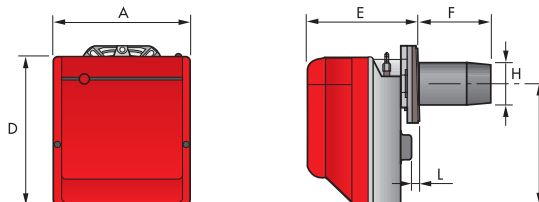

MODEL	A	D	E	F	H	I	L
▶ RG1RKD	234	254	196	111	84	210	4
▶ RG2D	255	280	202	115 - 185	95	230	10
▶ RG3D	300	345	228	142 - 212	123	285	12
▶ RG4D	300	345	228	142 - 212	123	285	12
▶ RG5D	300	345	247	154 - 294	125	285	12,5

Two Stage Light Oil Burners

GULLIVER RGD SERIES

RIELLO

BURNER - BOILER MOUNTING FLANGE

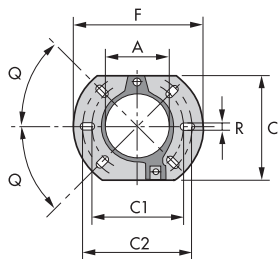

MODEL	A	C	C1	C2	F	Q	R
▶ RG1RKD	91	144	130	150	180	45°	11
▶ RG2D	106	166	140	168	189	45°	11
▶ RG3D	127	198	160	190	213	45°	11
▶ RG4D	127	198	160	190	213	45°	11
▶ RG5D	127	198	160	190	213	45°	11

PACKAGING

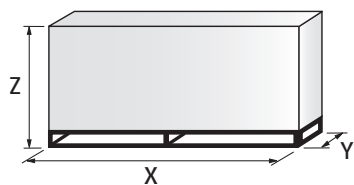

MODEL	X	Y	Z	kg
▶ RG1RKD	353	278	320	12
▶ RG2D	363	298	350	13
▶ RG3D	430	345	430	13
▶ RG4D	430	345	430	13
▶ RG5D	510	345	440	18

Specification

DESIGNATION OF SERIES

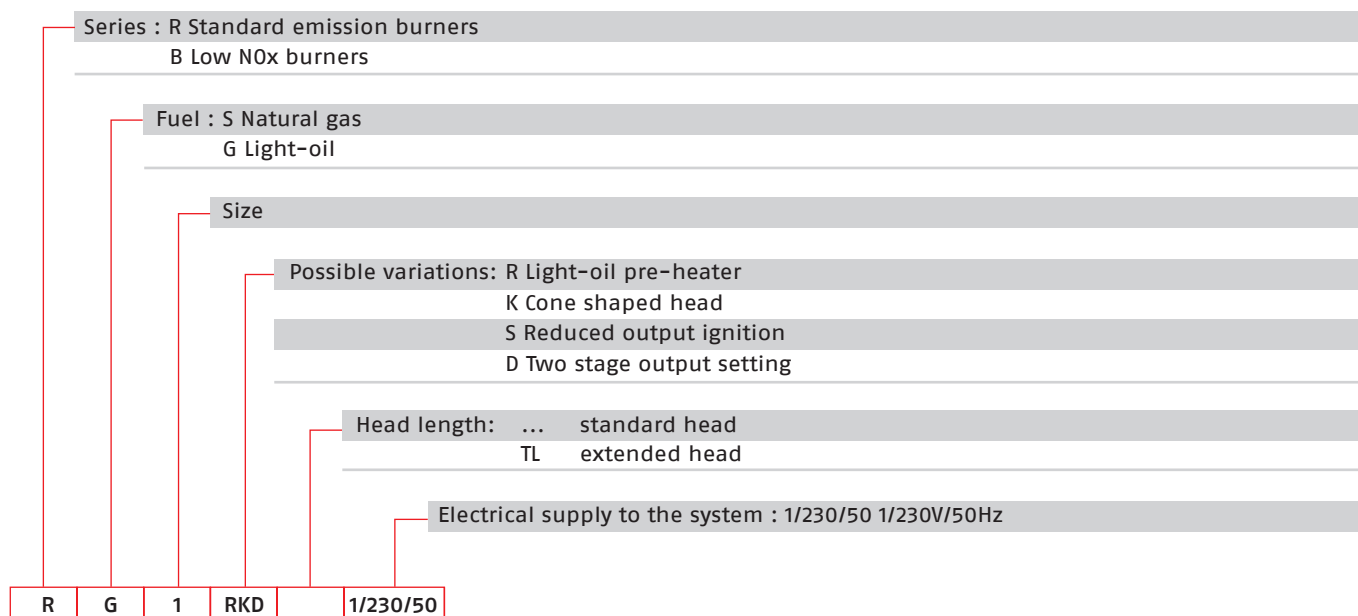

LIGHT OIL

Two Stage Light Oil Burners

GULLIVER RGD SERIES

Specification

STATE OF SUPPLY

Completely automatic monobloc light oil burners, two stage operation, made up of:

- Fan with forward curve blades
- Cover lined with sound-proofing material
- Air damper completely closed in stand by
- Air damper, with 1st and 2nd stage adjustment (2nd stage adjustment without removing the casing)
- Single phase electric motor 230 V, 50 Hz
- Combustion head fitted with:
 - stainless steel head cone, resistant to high temperatures
 - ignition electrodes
 - flame stability disk
- Geared pump for fuel supply, fitted with:
 - filter
 - pressure regulator
 - attachments for fitting a pressure gauge and vacuum meter
 - internal by-pass for preparing for single-pipe installations
- Fuel feed solenoid valve incorporated in the pump
- Photocell for flame detection
- Electronic flame control equipment
- Light oil nozzle
- IP X0D (IP 40) protection level
- PTC fuel pre-heater (optional).

Standard equipment:

- Two flexible pipes for connection to the light oil supply line
- Two nipples for connection to the pump
- Flange, screws and nuts for fixing
- Thermal screen
- 7-pin plug (not included in models with digital control box M0 550)
- 4-pin plug
- Instruction handbook for installation, use and maintenance
- Spare parts catalogue.

Available models

CODE	MODEL	HEAT OUTPUT		TOTAL ELECTRICAL POWER (kW)	NOTE
		(kW)	(kg/h)		
MODELS WITH ANALOGIC CONTROL BOX					
3736650	RG1RKD	1/230/50	14/17 - 60	1,2/1,45 - 5	0,290
3738050	RG2D	1/230/50	42/49 - 118	3,6/4,1 - 10	0,180
3739450	RG3D	1/230/50	65/83 - 178	5,5/7 - 15	0,390
3739750	RG4D	1/230/50	106/130 - 237	9/11 - 20	0,390
3739850	RG5D	1/230/50	95/142 - 296	8/12 - 25	0,470

Net calorific value: 11,8 kWh/kg; 10200 kcal/kg - Viscosity at 20°C: 4÷6 mm²/s (cSt).
The burners of RGD series are in according to EN 267.

GULLIVER RGD SERIES

Available models

CODE	MODEL		HEAT OUTPUT		TOTAL ELECTRICAL POWER (kW)	NOTE
			(kW)	(kg/h)		
MODELS WITH DIGITAL CONTROL BOX MO 550						
3736654	RG1RKD	1/230/50	14/17-60	1,2/1,45-5	0,290	
3738054	RG2D	1/230/50	42/49-118	3,6/4,1-10	0,180	
3739454	RG3D	1/230/50	65/83-178	5,5/7-15	0,390	
3739754	RG4D	1/230/50	106/130-237	9/11-20	0,390	
3739854	RG5D	1/230/50	95/142-296	8/12-25	0,470	

Net calorific value: 11,8 kWh/kg; 10200 kcal/kg - Viscosity at 20°C: 4÷6 mm²/s (cSt).
The burners of RGD series are in according to 2014/30/EU - 2014/35/EU - 2006/42 EC Directive and EN 267.

Burner accessories

Extended head kit

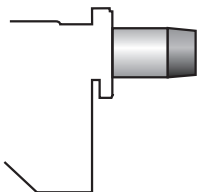

Kits of extended heads are available.

BURNER	STANDARD HEAD LENGTH (mm)	EXTENDED HEAD LENGTH (mm)	KIT CODE
▶ RG1RKD	111	181	3000982
▶ RG2D	115	180	3000964
▶ RG2D	115	300	3000967
▶ RG3D	142	210	3000965
▶ RG3D	142	300	3000968
▶ RG4D	142	210	3000966
▶ RG4D	142	300	3000969
▶ RG5D	159	300	3000981

Spacer kit

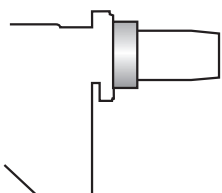

By using the special accessories, the burner can be withdrawn to reduce head penetration into the combustion chamber.

BURNER	SPACER THICKNESS S (mm)	KIT CODE
▶ RG1RKD	15	3007931
▶ RG2D	25	3000672
▶ RG3D - RG4D - RG5D	15	20103452

Two Stage Light Oil Burners

GULLIVER RGD SERIES

Burner accessories

Light oil filter



For cleaning light oil from dirty particles and impurities filters with the following features are available:

BURNER	FILTERING DEGREE (µm)	KIT CODE
► All models	60	3006561

Filter made up of aluminium body and stainless steel filtering cartridge; available singularly.

BURNER	FILTERING DEGREE (µm)	KIT CODE
► All models	60	3075011

Filter made up of aluminium cover, plastic tank and nylon filtering cartridge; available in packaging of 50 pieces.

Light oil filter/degassing unit



To solve problems of air or water in the oil circuit a special filter/degassing unit is available, made up of aluminium cover, plastic tank, stainless steel filtering cartridge, air release cap and water purge valve. It is available singularly.

BURNER	FILTERING DEGREE (µm)	KIT CODE
► All models	100	3000926

7-pin plug kit

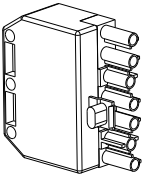

If necessary a 7-pin plug kit is available (in packaging of n. 5 pieces).

BURNER	KIT CODE
► All models	3000945

RIELLO 40 G SERIES

The Riello 40 G series of one stage light oil burners, is a complete range of products developed to respond to any request for home heating. The Riello 40 G series is available in ten different models, with an output ranging from 12 to 240 kW, divided into four different structures.

All the models use the same components designed by Riello for the Riello 40 G series. The high quality level guarantees safe working.

In developing these burners, special attention was paid to reducing noise, to the ease of installation and adjustment, obtaining the smallest size possible to fit into any sort of boiler available on the market.

All the models are approved by the EN 267 European Standard and conform to European Directives for EMC, Low Voltage, Machinery and Boiler Efficiency.

All the Riello 40 G burners are fired before leaving the factory.

Guidelines for installation of burners in conformity to EU Regulation:

A RIELLO burner (Heat Generator), where it is matched with a water-based boiler (Heater Housing) with a nominal output ≤ 400 kW, providing heat for heating purposes and heat to deliver sanitary hot water, can be installed:

- With boilers (heater housings) already in service in the field, for replacement of identical products, in conformity to Article 1, paragraph 2, point (G) of the EU Regulation No. 813/2013;
- With boilers (heater housings) on a new installation.



G3	23,8 ÷ 35,5 kW
G3R	23,8 ÷ 35,5 kW
G3RK	15,0 ÷ 35,0 kW
G5	28,0 ÷ 60,0 kW
G5R	28,0 ÷ 60,0 kW
G5RK	12,0 ÷ 60,0 kW
G7	29,0 ÷ 69,0 kW
G10	54,0 ÷ 120,0 kW
G20	95,0 ÷ 213,0 kW
G20S	95,0 ÷ 240,0 kW

FIRING RATES

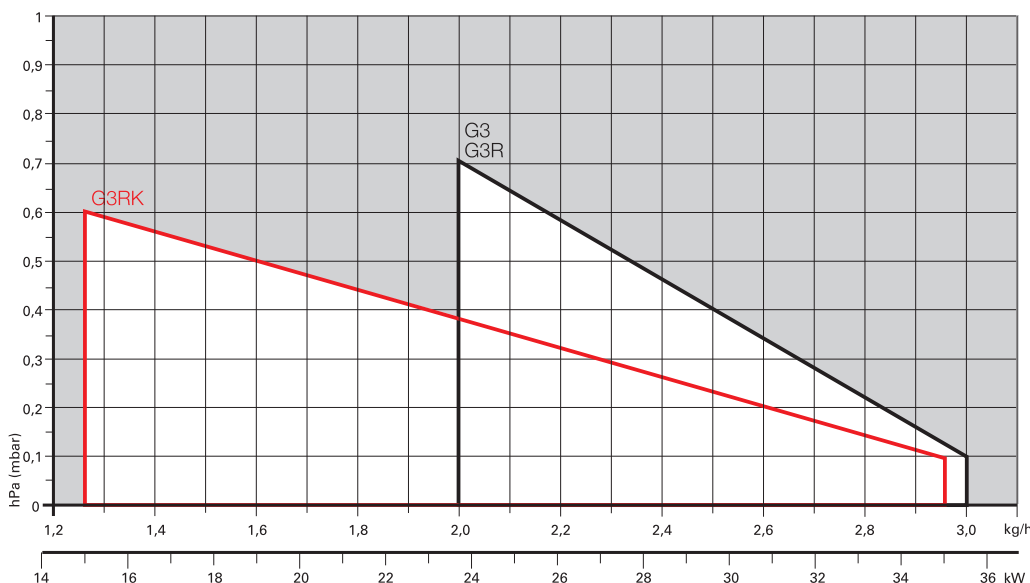

Useful working field for choosing the burner

Test conditions conforming to EN267
 Temperature: 20°C
 Pressure: 1013,5 mbar
 Altitude: 0 m a.s.l.

One Stage Light Oil Burners

RIELLO 40 G SERIES

FIRING RATES

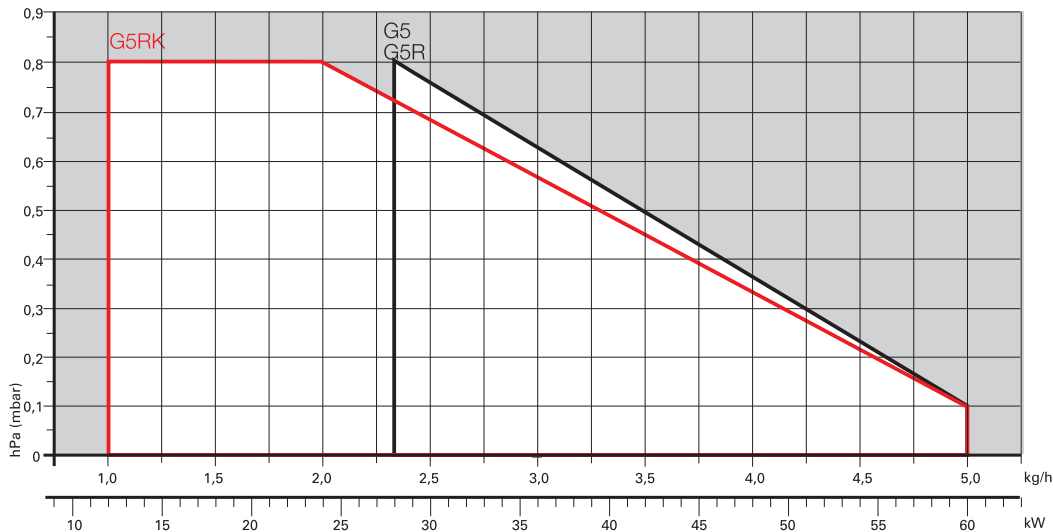

Useful working field for choosing the burner

Test conditions conforming to EN267
 Temperature: 20°C
 Pressure: 1013,5 mbar
 Altitude: 0 m a.s.l.

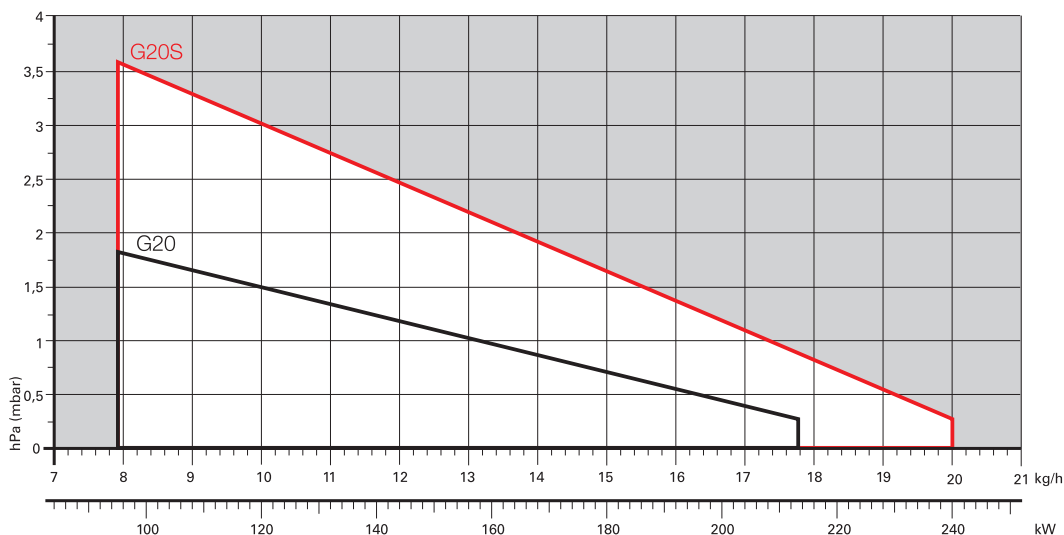
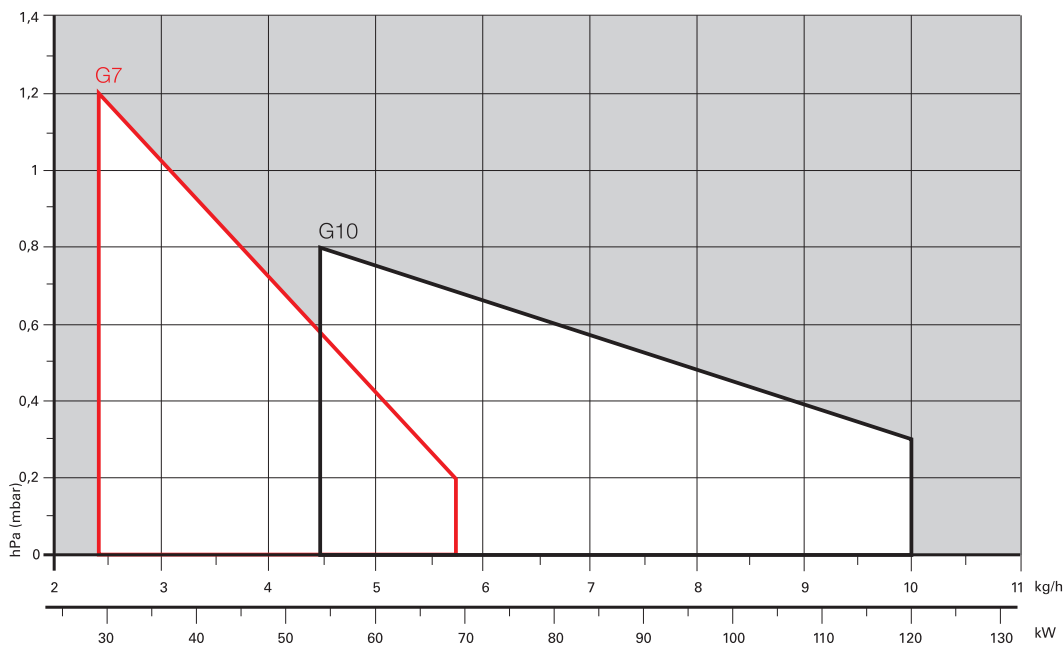

Overall dimensions (mm)

BURNER

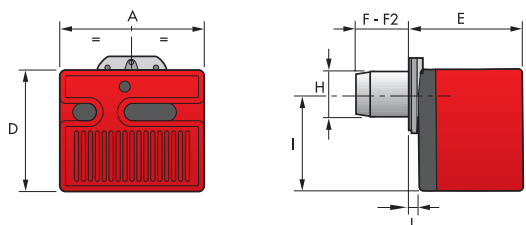

MODEL	A	D	E	F	F2	H	I	L
▶ G3	252	215	203	86	-	89	164	19
▶ G3R	252	215	203	86	-	89	164	19
▶ G3RK	252	215	203	97	115	89	164	19
▶ G5	272	233	236	107 - 180	-	89	180	37
▶ G5R	272	233	236	107	-	89	180	37
▶ G5RK	272	233	236	94	112	89	180	37
▶ G7	305	262	261	73	-	89	204	40
▶ G10	305	262	261	108 - 250	-	105	204	40
▶ G20	350	298	295	118 - 260	-	125	230	41
▶ G20S	350	298	295	118	-	125	230	41

BURNER - BOILER MOUNTING FLANGE

G3 - G3R - G3RK - G5 - G5R - G5RK - G7 - G10

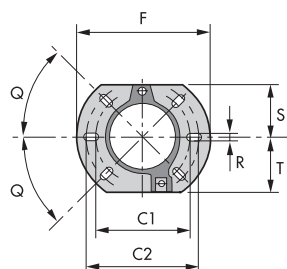

G20 - G20S

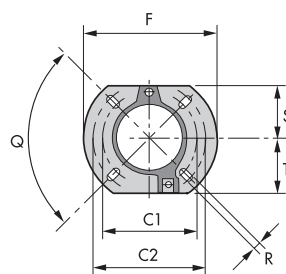

MODEL	C1	C2	F	Q	R	S	T
▶ G3 - G3R - G3RK - G5 - G5R - G5RK	130	150	180	45°	11	72	75
▶ G7 - G10	140	170	189	45°	11	83	83
▶ G20 - G20S	160	190	213	90°	11	99	99

PACKAGING

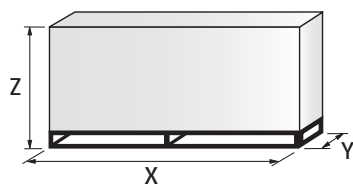

MODEL	X	Y	Z	kg
▶ G3	363	295	310	10
▶ G3R	363	295	310	10
▶ G3RK	363	295	310	10,5
▶ G5	383	315	325	12
▶ G5R	383	315	325	12
▶ G5RK	383	315	325	12
▶ G7	423	348	340	13
▶ G10	423	348	340	13
▶ G20	483	393	377	16
▶ G20S	483	393	377	17,5

One Stage Light Oil Burners

RIELLO 40 G SERIES

Specification

DESIGNATION OF SERIES

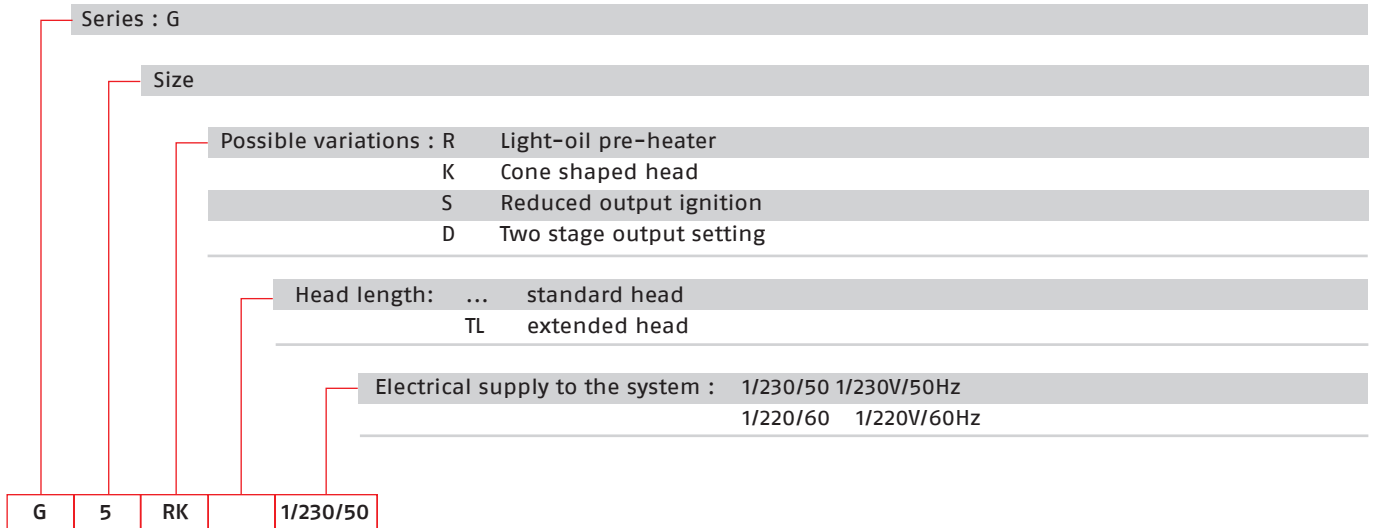

STATE OF SUPPLY

Completely automatic monobloc light oil burners, one stage operation, made up of:

- Fan with forward curve blades
- Metallic cover lined with sound-proofing material
- Air damper, completely closed in stand by, with adjustment
- Single phase electric motor 230 V, 50 Hz
- Combustion head fitted with:
 - stainless steel head cone, resistant to high temperatures
 - ignition electrodes
 - flame stability disk
- Geared pump for fuel supply, fitted with:
 - filter
 - pressure regulator
 - attachments for fitting a pressure gauge and vacuum meter
 - internal by-pass for preparing for single-pipe installations
- Fuel feed solenoid valve incorporated in the pump
- Photocell for flame detection
- Electronic flame control equipment
- Light oil nozzle
- IP X0D (IP 40) protection level
- Fuel pre-heater (optional)
- Reduced output ignition mechanism (optional).

Standard equipment:

- Two flexible pipes for connection to the light oil supply line
- Two nipples for connection to the pump
- Flange, screws and nuts for fixing
- Thermal gasket
- 7-pin plug (on request)
- Maintenance assembly
- Instruction handbook for installation, use and maintenance
- Spare parts catalogue.

RIELLO 40 G SERIES

Available models

CODE	MODEL		HEAT OUTPUT		TOTAL ELECTRICAL POWER (kW)	NOTE
			(kW)	(kg/h)		
3743125	G3	1/230/50	23,8 - 35,5	2 - 3	0,115	
3743831	G3R	1/230/50	23,8 - 35,5	2 - 3	0,165	
3744512	G5	1/230/50	28 - 60	2,3 - 5	0,130	
3744612	G5R	1/230/50	28 - 60	2,3 - 5	0,185	
3745959	G7	1/230/50	29 - 69	2,5 - 5,8	0,160	(1)
3746412	G10	1/230/50	54 - 120	4,5 - 10	0,170	
3746464	G10	1/220/60	54 - 120	4,5 - 10	0,200	
20062977	G10 TL	1/220/50	54 - 120	4,5 - 10	0,200	
3747412	G20	1/230/50	95 - 213	8 - 18	0,320	
3747459	G20	1/220/60	95 - 213	8 - 18	0,400	
20063100	G20 TL	1/220/50	95 - 213	8 - 18	0,400	
3748212	G20S	1/230/50	95 - 240	8 - 20	0,330	
3748259	G20S	1/220/60	95 - 240	8 - 20	0,410	

MODELS WITH 24V DC ELECTRICAL SUPPLY

3452030	G7	24V DC	29 - 69	2,45 - 5,8	0,3	
20006157	G10	24V DC	54 - 120	4,5 - 10	0,3	
3452736	G20	24V DC	95 - 201	8 - 17	0,3	

(1) UK version

Net calorific value: 11,8 kWh/kg - 10200 kcal/kg - Viscosity at 20°C: 4÷6 mm²/s (cSt)

The burners of G series are in according to 2014/30/EU - 2014/35/EU - 2006/42 EC Directive and EN 267.

Bio fuels

Riello Burners is able to offer technical variants which allow burners to be used within environmental heating, process or special applications. These applications now include solutions for liquid Bio fuels (i.e. biodiesel and vegetable oil). Our experience in research and development and field applications with organic origin Bio fuels has resulted in Riello being able to offer a wide range of solutions for the combustion of Bio fuels.

One Stage Light Oil Burners

RIELLO 40 G SERIES

Burner accessories

Remote control release kit for 530-531 control boxes

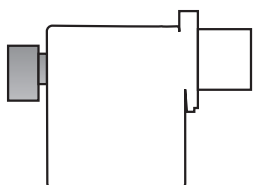

The 530-531 control boxes can be remotely released using an electric command kit. This kit must be installed in conformity with current regulations in force.

BURNER	KIT CODE
► All models	3001030

Extended head kit

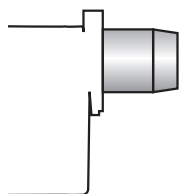

Kits of extended heads are available.

BURNER	STANDARD HEAD LENGTH (mm)	EXTENDED HEAD LENGTH (mm)	KIT CODE
► G3 - G3R	107	121	3000686
► G3 - G3R	107	121 inox	3000687
► G5 - G5R	107	121	3000686
► G5 - G5R	107	121 inox	3000687
► G10	108	168	3000643
► G10	108	250	3000770
► G20 - G20S	118	178	3000644
► G20 - G20S	118	260	3000771

Spacer kit

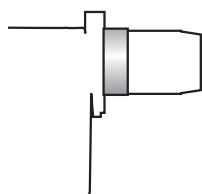

Using the special accessories, the burner can be pulled back to reduce head penetration into the combustion chamber.

BURNER	SPACER THICKNESS S (mm)	KIT CODE
► G3 - G3R - G3RK - G5 - G5R - G5RK - G7	25	3000642
► G10	25	3000672
► G20 - G20S	15	20103452

Inlet air aspiration kit

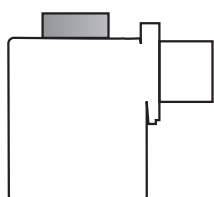

This kit allows to channel the external air directly into the burner and is available as accessory for models:

BURNER	KIT CODE
► G3 - G3R - G3RK	20027471
► G5 - G5R - G5RK	20027574
► G7 - G10	20027577
► G20 - G20S	20027580

Burner accessories

Light oil filter



For cleaning light oil from dirty particles and impurities filters with the following features are available:

BURNER	FILTERING DEGREE (µm)	KIT CODE
► All models	60	3006561

Filter made up of aluminium body and stainless steel filtering cartridge; available singularly.

BURNER	FILTERING DEGREE (µm)	KIT CODE
► All models	60	3075011

Filter made up of aluminium cover, plastic tank and nylon filtering cartridge; available in packaging of 50 pieces.

Light oil filter/degassing unit



To solve problems of air or water in the oil circuit a special filter/degassing unit is available, made up of aluminium cover, plastic tank, stainless steel filtering cartridge, air release cap and water purge valve. It is available singularly.

BURNER	FILTERING DEGREE (µm)	KIT CODE
► All models	100	3000926

7-pin plug kit

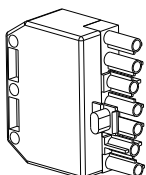

If necessary a 7-pin plug kit is available (in packaging of n. 5 pieces).

BURNER	KIT CODE
► All models	3000945

Hour counter kit for 530 SE and 531 SE control boxes



To measure the burner working time a hour counter kit is available.

BURNER	KIT CODE
► All models	3000904

7-pole socket kit for 530 SE and 531 SE control boxes

For burner without pre installed socket a 7-pole socket kit with cable is available.

BURNER	KIT CODE
► All models	3001065

RIELLO 40 GI SERIES

The Riello 40 GI series of two stage light oil burners, is a complete range of products developed to respond to any request for residential heating. The Riello 40 GI series is available in three different models, with an output ranging from 54 to 240 kW, divided in two different structures.

All the models use the same components designed by Riello for the Riello 40 GI series. The high quality level guarantees safe working.

In developing these burners, special attention was paid to reducing noise, to the ease of installation and adjustment, to obtaining the smallest size possible to fit into any sort of boiler available on the market.

All the models are approved by the EN 267 European Standard and conform to European Directives for EMC, Low Voltage, Machinery and Boiler Efficiency.

All the Riello 40 GI burners are fired before leaving the factory.

Guidelines for installation of burners in conformity to EU Regulation:

A RIELLO burner (Heat Generator), where it is matched with a water-based boiler (Heater Housing) with a nominal output ≤ 400 kW, providing heat for heating purposes and heat to deliver sanitary hot water, can be installed:

- With boilers (heater housings) already in service in the field, for replacement of identical products, in conformity to Article 1, paragraph 2, point (G) of the EU Regulation No. 813/2013;
- With boilers (heater housings) on a new installation.



G10I	44/54 ÷	120 kW
G20I	71/95 ÷	240 kW
G20D	71/95 ÷	240 kW

FIRING RATES

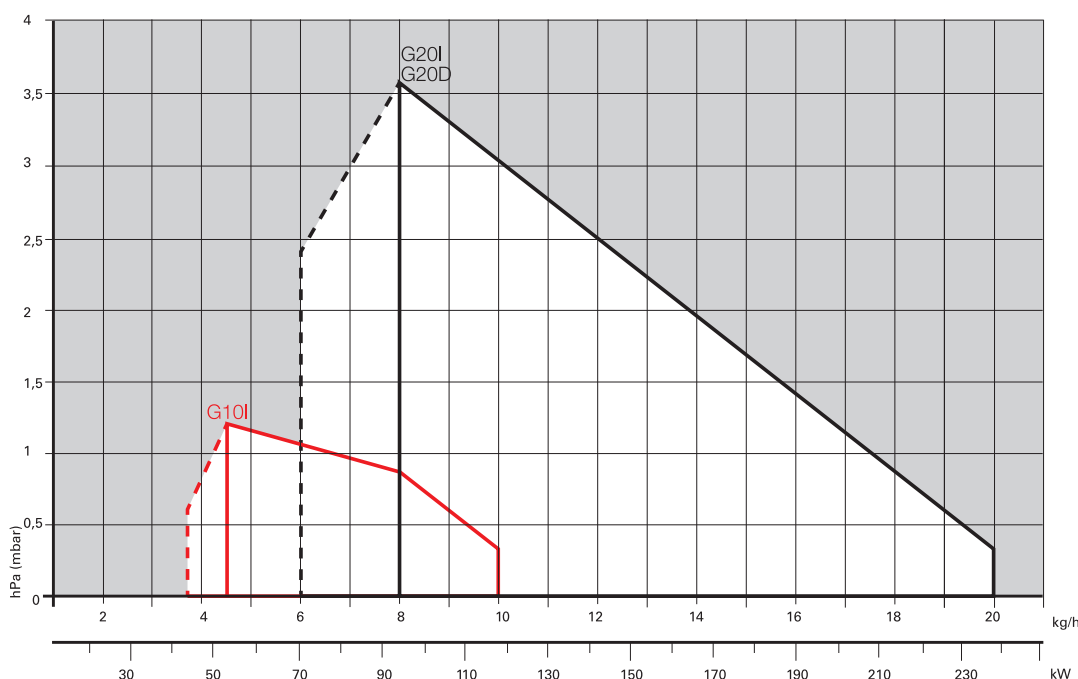

Useful working field for choosing the burner



1st stage operation range

Test conditions conforming to EN267
 Temperature: 20°C
 Pressure: 1013,5 mbar
 Altitude: 0 m a.s.l.

Two Stage Light Oil Burners

RIELLO 40 GI SERIES

Overall dimensions (mm)

BURNER

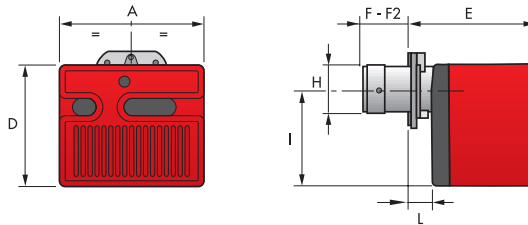

MODEL	A	D	E	F	F2	H	I	L
▶ G10I	305	262	261	108	-	105	204	40
▶ G20I - G20D	350	298	295	118	-	125	230	41

BURNER - BOILER MOUNTING FLANGE

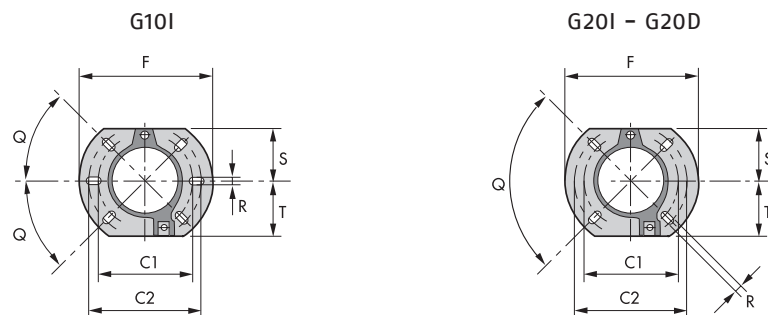

MODEL	C1	C2	F	Q	R	S	T
▶ G10I	140	170	189	45°	11	83	83
▶ G20I	160	190	213	90°	11	99	99
▶ G20D	160	190	213	90°	11	99	99

PACKAGING

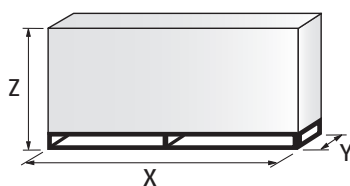

MODEL	X	Y	Z	kg
▶ G10I	423	348	340	13
▶ G20I	483	393	377	15
▶ G20D	483	393	377	16,3

Specification

DESIGNATION OF SERIES

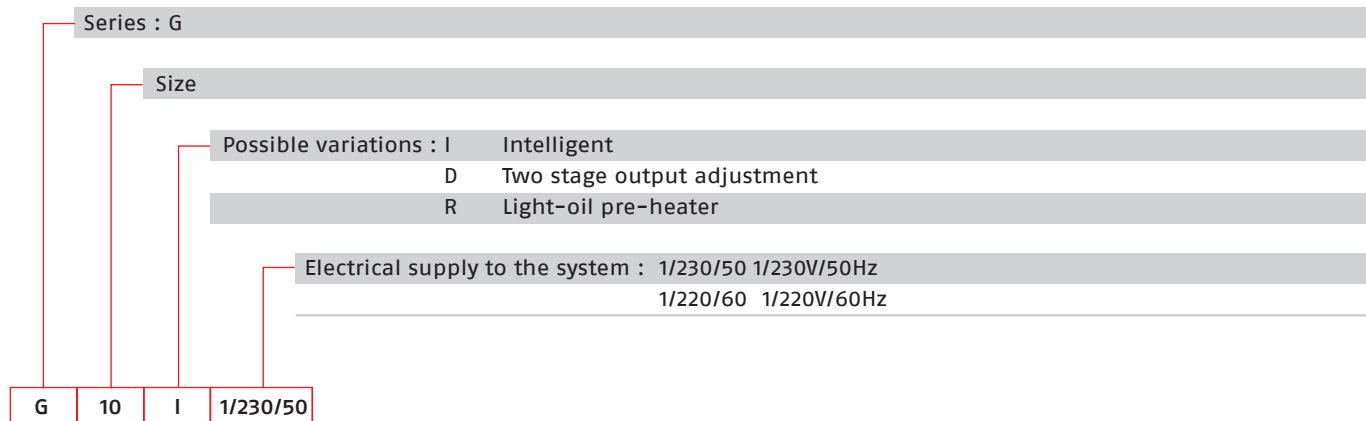

STATE OF SUPPLY

Completely automatic monobloc light oil burners, two stage operation, made up of:

- Fan with forward curve blades
- Cover lined with sound-proofing material
- Servomotor to drive the air damper to fully closed position at stand-by, low and high fire position
- Single phase electric motor 230 V, 50 Hz
- Combustion head fitted with:
 - stainless steel head cone, resistant to high temperatures
 - ignition electrodes
 - flame stability disk
- Geared pump for fuel supply, fitted with:
 - filter
 - pressure regulator
 - attachments for fitting a pressure gauge and vacuum meter
 - internal by-pass for preparing for single-pipe installations
- Fuel feed solenoid valves incorporated in the pump
- Photocell for flame detection
- Electronic flame control equipment
- Light oil nozzle
- IP X0D (IP 40) protection level
- Reduced output ignition mechanism.

Standard equipment:

- Two flexible pipes for connection to the light oil supply line
- Two nipples for connection to the pump
- Flange, screws and nuts for fixing
- Thermal screen
- 7-pin plug
- 4-pin plug
- External probe (for "I" versions only)
- Maintenance assembly
- Instruction handbook for installation, use and maintenance
- Spare parts catalogue.

Two Stage Light Oil Burners

RIELLO 40 GI SERIES

Available models

CODE	MODEL		HEAT OUTPUT		TOTAL ELECTRICAL POWER (kW)	NOTE
			(kW)	(kg/h)		
3746613	G10I	1/230/50	44/54 - 120	3,7/4,5 - 10	0,170	
3746686	G10D	1/220/60	44/54 - 120	3,7/4,5 - 10	0,200	(1)
3748414	G20D	1/230/50	71/95 - 240	6/8 - 20	0,330	
3748415	G20D	1/220/60	71/95 - 231	6/8 - 19,5	0,400	(1)

(1) Philippines version.

Net calorific value: 11,8 kWh/kg - 10200 kcal/kg - Viscosity at 20°C: 4±6 mm²/s (cSt)

The burners of GI series are in according to 2014/30/EU - 2014/35/EU - 2006/42 EC Directive and EN 267.

Bio fuels

Riello Burners is able to offer technical variants which allow burners to be used within environmental heating, process or special applications. These applications now include solutions for liquid Bio fuels (i.e. biodiesel and vegetable oil). Our experience in research and development and field applications with organic origin Bio fuels has resulted in Riello being able to offer a wide range of solutions for the combustion of Bio fuels.

Burner accessories

Remote control release kit for 530-531 control boxes

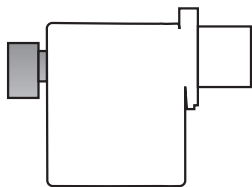

The 530-531 control boxes can be remotely released using an electric command kit. This kit must be installed in conformity with current regulations in force.

BURNER	KIT CODE
► All models	3001030

Extended head kit

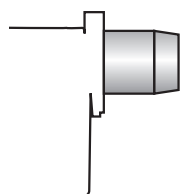

Kits of extended heads are available.

BURNER	STANDARD HEAD LENGTH (mm)	EXTENDED HEAD LENGTH (mm)	KIT CODE
► G10I	108	168	3000643
► G20I	118	178	3000644
► G20D	118	260	3000771

Burner accessories

Spacer kit

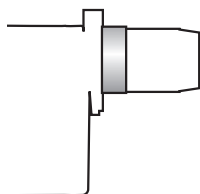

Using the special accessories, the burner can be pulled back to reduce head penetration into the combustion chamber.

BURNER	SPACER THICKNESS S (mm)	KIT CODE
► G10I	25	3000672
► G20I - G20D	15	20103452

Light oil filter



For cleaning light oil from dirty particles and impurities filters with the following features are available:

BURNER	FILTERING DEGREE (µm)	KIT CODE
► All models	60	3006561

Filter made up of aluminium body and stainless steel filtering cartridge; available singularly.

BURNER	FILTERING DEGREE (µm)	KIT CODE
► All models	60	3075011

Filter made up of aluminium cover, plastic tank and nylon filtering cartridge; available in packaging of 50 pieces.

Light oil filter/degassing unit



To solve problems of air or water in the oil circuit a special filter/degassing unit is available, made up of aluminium cover, plastic tank, stainless steel filtering cartridge, air release cap and water purge valve. It is available singularly.

BURNER	FILTERING DEGREE (µm)	KIT CODE
► All models	100	3000926

7-pin plug kit

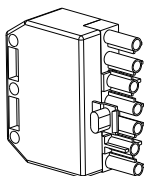

If necessary a 7-pin plug kit is available (in packaging of n. 5 pieces).

BURNER	KIT CODE
► All models	3000945

Hour counter kit for 530 SE and 531 SE control boxes



To measure the burner working time a hour counter kit is available.

BURNER	KIT CODE
► All models	3000904

RL/1 SERIES

The RL/1 burners series covers a firing range from 107 to 398 kW, and it has been designed for use in low or medium temperature hot water boilers, hot air or steam boilers, diathermic oil boilers.

Optimisation of sound emissions is guaranteed by the special design of the air suction circuit **and by incorporated sound proofing material**.

Special care has been paid to keeping overall dimensions compact and to easy servicing.

The elevated fans and combustion head performance guarantees flexibility of use and excellent operation at all firing rates. A wide range of accessories guarantees elevated working flexibility.

Guidelines for installation of burners in conformity to EU Regulation:

A RIELLO burner (Heat Generator), where it is matched with a water-based boiler (Heater Housing) with a nominal output ≤ 400 kW, providing heat for heating purposes and heat to deliver sanitary hot water, can be installed:

- With boilers (heater housings) already in service in the field, for replacement of identical products, in conformity to Article 1, paragraph 2, point (G) of the EU Regulation No. 813/2013;
- With boilers (heater housings) on a new installation.



RL 34/1 MZ

107 ÷ 398 kW

FIRING RATES

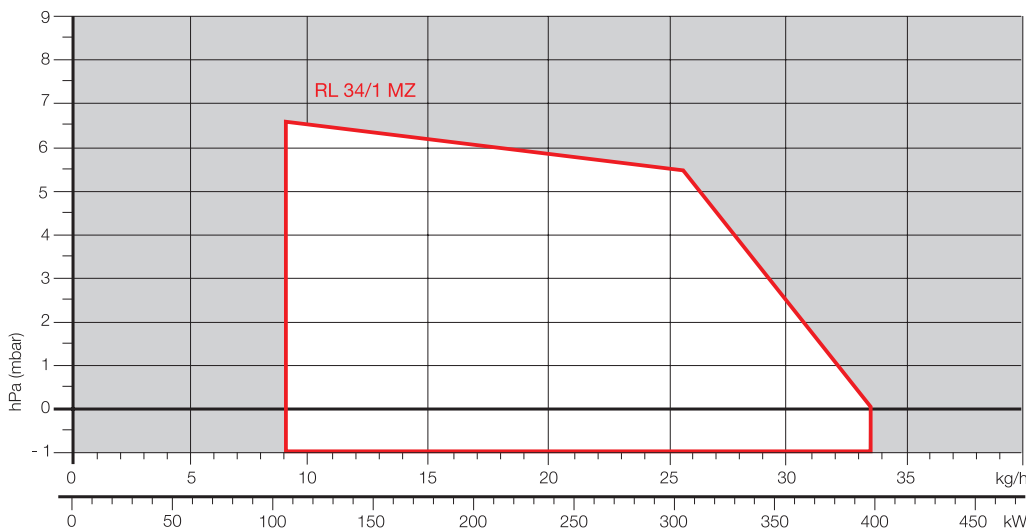

Useful working field for choosing the burner

Test conditions conforming to EN267
 Temperature: 20°C
 Pressure: 1013,5 mbar
 Altitude: 0 m a.s.l.

One Stage Light Oil Burners

RL/1 SERIES

Overall dimensions (mm)

BURNER

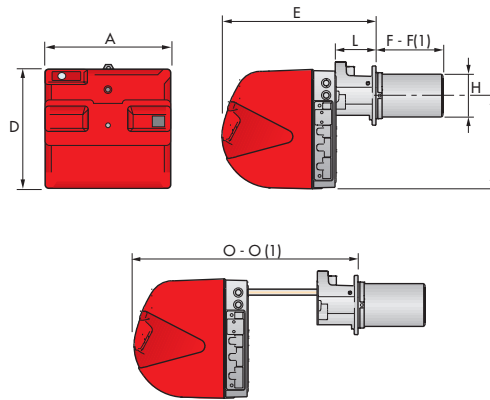

MODEL	A	D	E	F - F(1)	H	I	L	O - O(1)
► RL 34/1 MZ	442	422	508	216 - 351	140	305	138	780 - 915

(1) dimension with extended head

BURNER - BOILER MOUNTING FLANGE

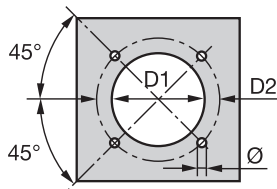

MODEL	D1	D2	Ø
► RL 34/1 MZ	160	224	M8

PACKAGING

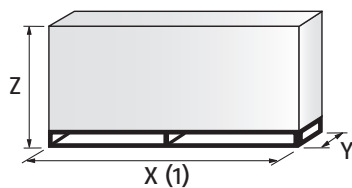

MODEL	X (1)	Y	Z	kg
► RL 34/1 MZ	1000	485	500	32

(1) Length with short and extended head

RL/1 SERIES

Specification

DESIGNATION OF SERIES

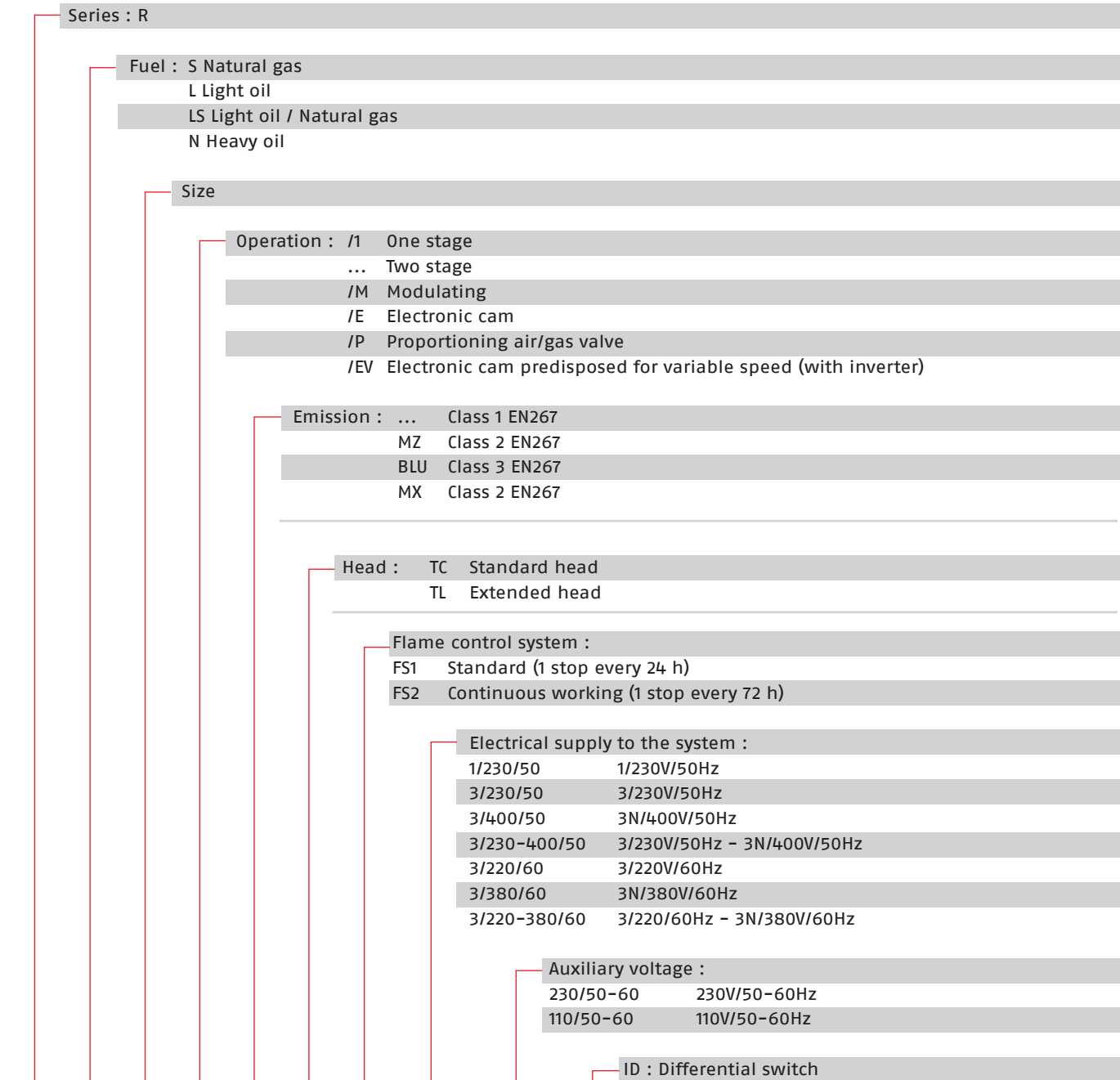

R	L	34	/1	MZ	TC	FS1	1/230/50	230/50-60	
---	---	----	----	----	----	-----	----------	-----------	--

BASIC DESIGNATION

EXTENDED DESIGNATION

One Stage Light Oil Burners

RL/1 SERIES

Specification

STATE OF SUPPLY

Monoblock forced draught oil burner with one stage operation, fully automatic, made up of:

- Air suction circuit **with sound proofing material**
- High performance fan with forward curve blades
- Air damper for air setting
- Starting motor at 2800 rpm, single-phase, 230V / 50-60Hz
- Combustion head, that can be set on the basis of required output, fitted with:
 - stainless steel end cone, resistant to corrosion and high temperatures
 - ignition electrodes
 - flame stability disk
- Fan pressure test point
- Gears pump for high pressure fuel supply, fitted with:
 - filter
 - pressure regulator
 - connections for installing a pressure gauge and vacuumeter
 - internal by-pass for single pipe installation
- Valve unit with a double oil delivery valve on the output circuit
- Photocell for flame detection
- Microprocessor-based burner safety control box, with diagnostic function
- Plugs and socket for electrical connections, accessible from the external of the cover
- Flame inspection window
- Slide bars for easier installation and maintenance
- Protection filter against radio interference
- IP X0D (IP 40) electric protection level.

Standard equipment:

- 2 flexible pipes for connection to the oil supply network
- 2 gaskets for the flexible pipes
- 2 nipples for connection to the pump
- 1 thermal screen
- 2 slide bar extensions (for model with long blast tube)
- 4 screws for fixing the burner flange to the boiler
- 1 7pin plug for electrical connection
- Instruction handbook for installation, use and maintenance
- Spare parts catalogue.

Available models

CODE	MODEL	HEAT OUTPUT		TOTAL ELECTRICAL POWER (kW)	NOTE
		(kW)	(kg/h)		
3470110	RL 34/1 MZ TC FS1 1/230/50-60 230/50-60	107 - 398	9 - 34	0,6	
3470111	RL 34/1 MZ TL FS1 1/230/50-60 230/50-60	107 - 398	9 - 34	0,6	

Net calorific value: 11,8 kWh/kg - 10200 kcal/kg - Viscosity at 20°C: 4÷6 mm²/s (cSt)
The burners of RL/1 series are in according to 2014/30/EU - 2014/35/EU - 2006/42 EC Directive and EN 267.

Burner accessories

Nozzles



The nozzles must be ordered separately. The following table shows the features and codes on the basis of the maximum required fuel output.

NOTE: each burner needs N°2 nozzles.

BURNER	NOZZLE TYPE	GPH	RATED OUTPUT (kg/h)			NOZZLE CODE
			at 10 bar	at 12 bar	at 14 bar	
► RL 34/1 MZ	60°A	1,00	4,1	4,5	4,9	3042078
	60°A	1,25	4,7	5,2	5,6	3042094
	60°A	1,50	5,7	6,3	6,8	3042108
	60°A	1,75	6,7	7,3	7,9	3042114
	60°A	2,00	7,7	8,5	9,2	3042124
	60°A	2,50	9,6	10,6	11,5	3042144
	60°A	3,00	11,5	12,7	13,8	3042148
	60°A	3,50	13,5	14,8	16,1	3042164
	60°A	4,00	15,4	17	18,4	3042174

Extended heads

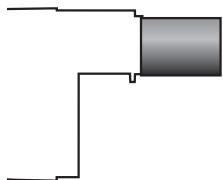

"Standard head" burners can be transformed into "extended head" versions, by using the special kit. The kit available, giving the original and the extended lengths, is listed below.

BURNER	'STANDARD' HEAD LENGTH (mm)	'EXTENDED' HEAD LENGTH (mm)	KIT CODE
► RL 34/1 MZ	216	351	3010426

Spacer kit

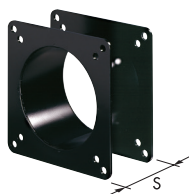

If burner head penetration into the combustion chamber needs reducing, varying thickness spacers are available, as given in the following table:

BURNER	SPACER THICKNESS S (mm)	KIT CODE
► RL 34/1 MZ	110	3010095

Sound proofing box

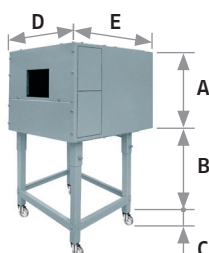

If noise emission needs reducing even further, sound-proofing boxes are available. When a lower "B" dimension is required, it is available the Box Support Kit code 20065135 which allows to reduce it at the fixed dimension of 55 mm. The sound-proofing boxes are not suitable for outdoor use.

BURNER	BOX TYPE	A (mm)	B (mm) min-max	C (mm)	D (mm)	E (mm)	[dB(A)] (*)	BOX CODE
► RL 34/1 MZ	C1/3	650	372 - 980	110	690	770	10	3010403

(*) Average noise reduction according to EN 15036-1 standard

One Stage Light Oil Burners

RL/1 SERIES

Burner accessories

Degasing unit



With single pipe systems, you can find air in the oil sucked by the pump that comes from the oil itself due to negative pressure or to a faulty seal. To solve this problem, we recommend fitting a degassing unit near the burner. Two versions are available with or without filter:

BURNER	FILTER	KIT CODE
► RL 34/1 MZ	With filter	3010055

Connection flange kit

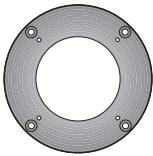

A kit is available for use where the burner opening on the boiler is of excessive diameter.

BURNER	KIT CODE
► RL 34/1 MZ	3010138

Volt free contact kit

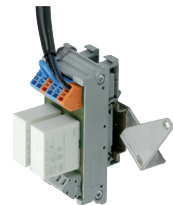

A volt free contact kit is available for installation onto the burner. It can be used for a remote interface between burner operating signals. Every burner can be equipped with a single kit to remote the flame presence signal and the burner lockout indication.

BURNER	KIT CODE
► RL 34/1 MZ	3010419

PC interface kit



To connect the control box to a personal computer for the transmission of operation, fault signals and detailed service information, an interface adapter with PC software are available.

BURNER	KIT CODE
► RL 34/1 MZ	3002719

Ground fault interrupter kit



A "Ground fault interrupter kit" is available as a safety device for electrical system fault.

BURNER	KIT CODE
► RL 34/1 MZ	3010448

Burner accessories

Post-ventilation kit

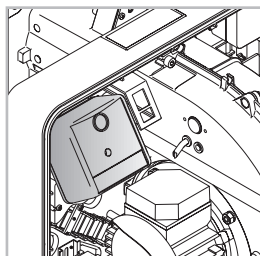

To have 20 s ventilation after opening of thermostats chain, a special kit is available.

BURNER	KIT CODE
► RL 34/1 MZ	3010453

Hours counter kit

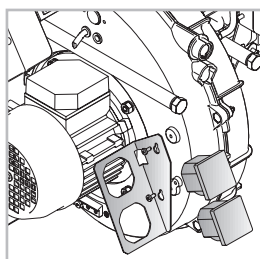

To measure the burner working time a hours counter kit is available.

BURNER	KIT CODE
► RL 34/1 MZ	3010450

Protection kit (electromagnetic interferences)

When the burner is installed in a room particularly subject to electromagnetic interference (signals emitted over 10 V/m) due for example to INVERTER presence or in systems where the lengths of the thermostat connections is over 20 meters, this specific protection kit is available as an interface between the thermostatic controls and the burner.

BURNER	KIT CODE
► All models	3010386

Head kit for “reverse flame chamber”



In certain cases, the use of the burner on reverse flame boilers can be improved by using an additional cylinder.

BURNER	STANDARD HEAD LENGTH WITH CYLINDER (mm)	EXTENDED HEAD LENGTH WITH CYLINDER (mm)	KIT CODE
► RL 34/1	319	429	3010178

RL SERIES

The RL series of burners covers a firing range from 154 to 2700 kW, and it has been designed for use in low or medium temperature hot water boilers, hot air or steam boilers, diathermic oil boilers.

Operation is "two stage"; the burners are fitted with a microprocessor-based control panel, which supplies indication of burner status and fault causes.

Optimisation of sound emissions is guaranteed by the special design of the air suction circuit **and by incorporated sound proofing material**. The elevated performance of the fans and combustion head, guarantee flexibility of use and excellent working at all firing rates.

The exclusive design ensures reduced dimensions, simple use and maintenance. A wide range of accessories guarantees elevated working flexibility.

Guidelines for installation of burners in conformity to EU Regulation:

A RIELLO burner (Heat Generator), where it is matched with a water-based boiler (Heater Housing) with a nominal output ≤ 400 kW, providing heat for heating purposes and heat to deliver sanitary hot water, can be installed:

- With boilers (heater housings) already in service in the field, for replacement of identical products, in conformity to Article 1, paragraph 2, point (G) of the EU Regulation No. 813/2013;
- With boilers (heater housings) on a new installation.



LIGHT OIL

RL 34 MZ	97/154 ÷	395 kW
RL 44 MZ	155/235 ÷	485 kW
RL 50	148/296 ÷	593 kW
RL 64 MZ	206/391 ÷	830 kW
RL 70	255/474 ÷	830 kW
RL 100	356/711 ÷	1186 kW
RL 130	486/948 ÷	1540 kW
RL 190	759/1423 ÷	2443 kW
RL 250 MZ	600/1250 ÷	2700 kW

FIRING RATES

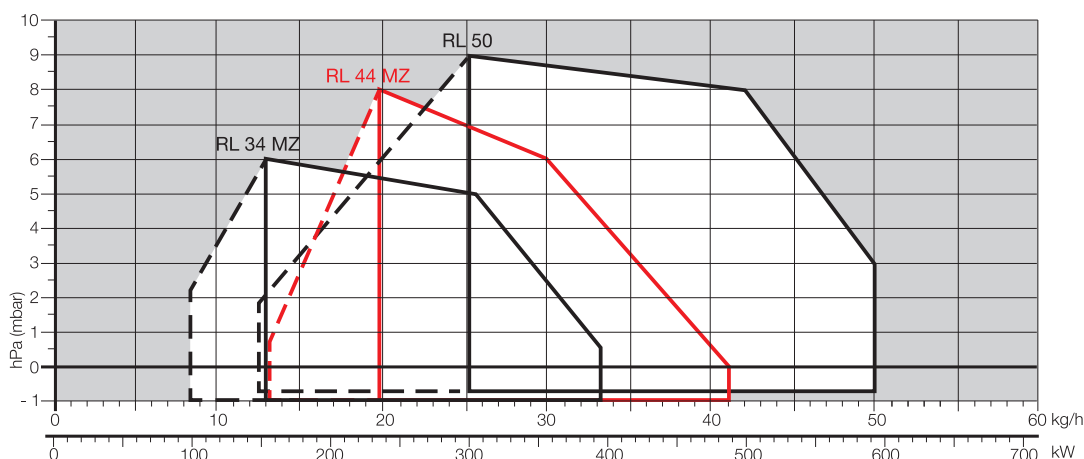

Useful working field for choosing the burner

Modulation range

Test conditions conforming to EN267
 Temperature: 20°C
 Pressure: 1013,5 mbar
 Altitude: 0 m a.s.l.

Two Stage Light Oil Burners

RL SERIES

FIRING RATES

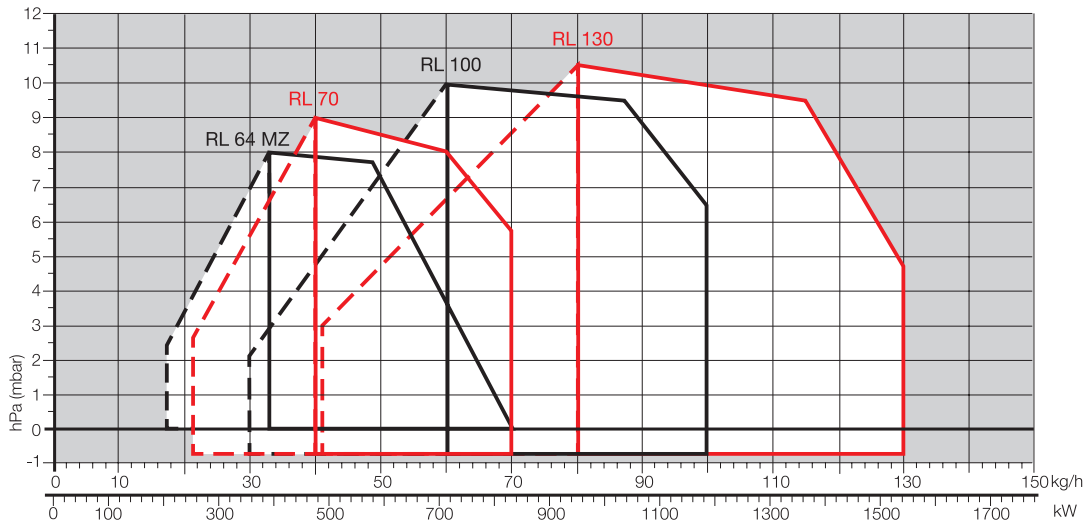

□ Useful working field for choosing the burner

--- Modulation range

Test conditions conforming to EN267
 Temperature: 20°C
 Pressure: 1013,5 mbar
 Altitude: 0 m a.s.l.

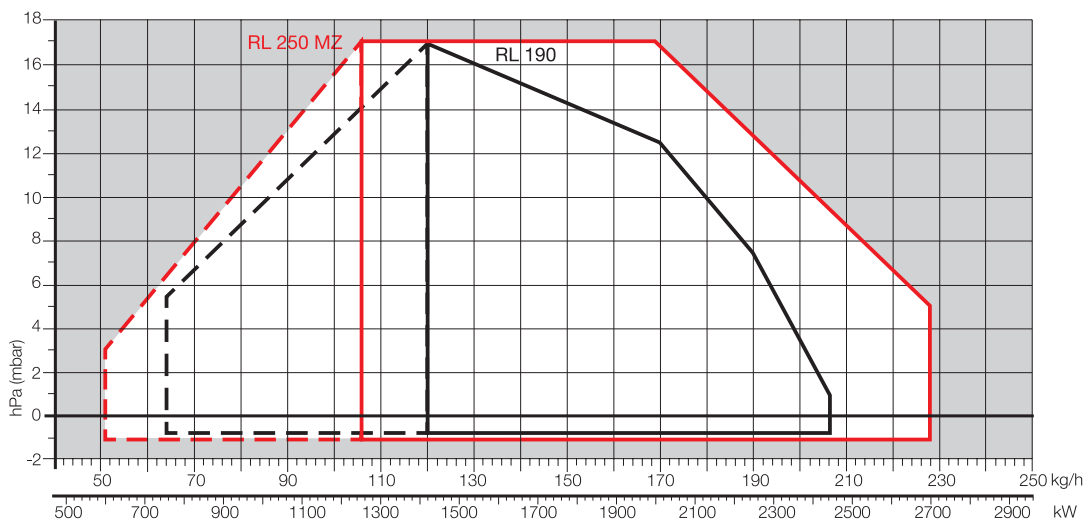

RL SERIES

Overall dimensions (mm)

BURNER

RL 34 - 44 MZ

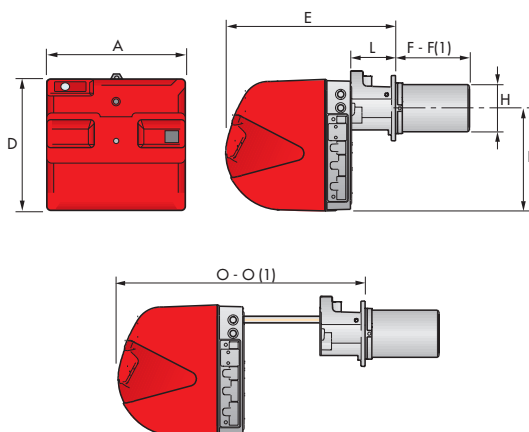

RL 50

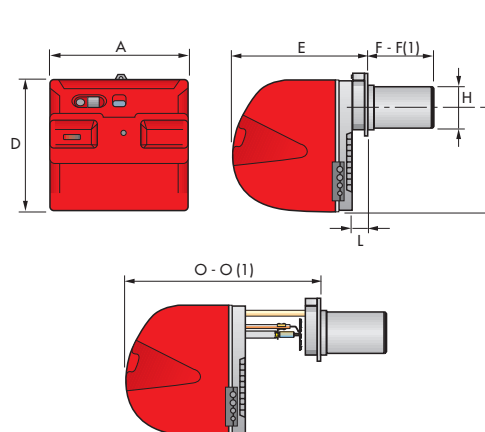

MODEL	A	D	E	F - F(1)	H	I	L	O - O(1)
▶ RL 34 MZ	442	422	508	216 - 351	140	305	138	780 - 915
▶ RL 44 MZ	442	422	508	216 - 351	152	305	138	780 - 915
▶ RL 50	476	474	468	216 - 351	152	352	52	672 - 807

(1) dimension with extended head

RL 64 MZ

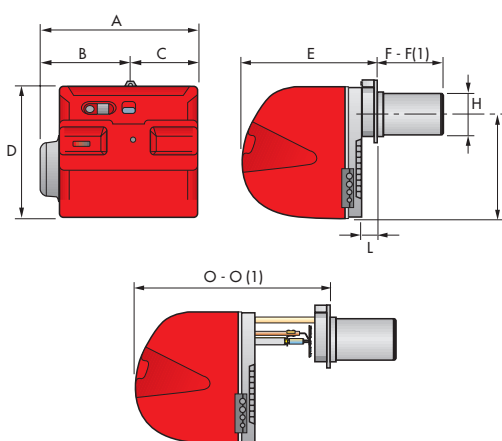

RL 70 - 100 - 130 - 190 - 250 MZ

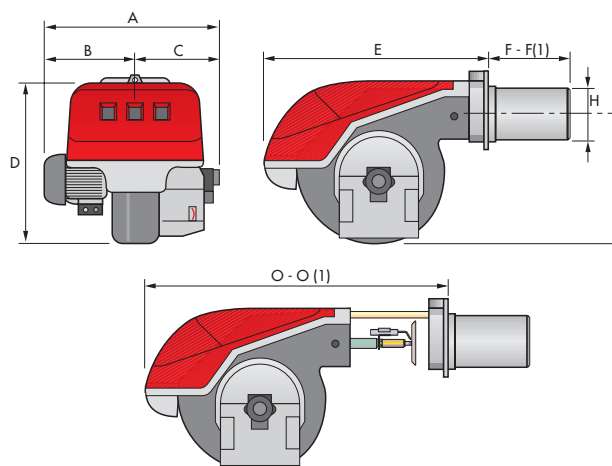

MODEL	A	B	C	D	E	F - F(1)	H	I	L	O - O(1)
▶ RL 64 MZ	538	300	238	490	477	250 - 385	179	335	60	680 - 815
▶ RL 70	580	296	284	555	680	250 - 385	179	430	-	951 - 1086
▶ RL 100	599	312	287	555	680	250 - 385	179	430	-	951 - 1086
▶ RL 130	625	338	287	555	680	250 - 385	189	430	-	951 - 1086
▶ RL 190	756	366	390	555	712	370 - 530*	222	430	-	1166 - -
▶ RL 250 MZ	910	432	478	555	705	378 - 528*	222	436	-	1163 - -

(1) dimension with extended head
 * by installation of extended head kit

Two Stage Light Oil Burners

RL SERIES

Overall dimensions (mm)

BURNER - BOILER MOUNTING FLANGE

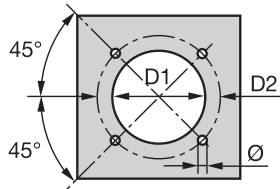

MODEL	D1	D2	Ø
▶ RL 34 MZ	160	224	M8
▶ RL 44 MZ	160	224	M8
▶ RL 50	160	224	M8
▶ RL 64 MZ	185	275-325	M12
▶ RL 70	185	275-325	M12
▶ RL 100	185	275-325	M12
▶ RL 130	195	275-325	M12
▶ RL 190	230	325-368	M16
▶ RL 250 MZ	230	325-368	M16

PACKAGING

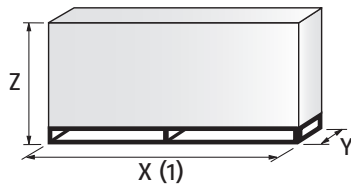

MODEL	X (1)	Y	Z	kg
▶ RL 34 MZ	1010	520	510	32
▶ RL 44 MZ	1010	520	510	33
▶ RL 50	1200	520	502	39
▶ RL 64 MZ	1200	560	520	42
▶ RL 70	1410	692	655	60
▶ RL 100	1410	692	655	63
▶ RL 130	1410	692	655	66
▶ RL 190	1410	985	655	75
▶ RL 250 MZ	1410	1040	655	140

(1) Length with short and extended head

Specification

DESIGNATION OF SERIES

Series: R									
Fuel: S Natural Gas									
SP LPG									
L Light oil									
LS Light oil/Methane									
N Heavy oil									
Size									
Setting: /1 Single stage									
... Two stage									
/M Modulating									
Emission: ... Class 1 EN267									
MZ Class 2 EN267									
BLU Class 3 EN267									
MX Class 2 EN267									
Head length: TC standard head									
TL extended head									
Flame control system: FS1 Standard (1 stop every 24 h)									
FS2 Continuous working (1 stop every 72 h)									
Electrical supply to the system:									
1/230/50		1/230V/50Hz							
1/220-230/50-60		1/220-230V/50-60Hz							
3/230/50		3/230V/50Hz							
3/400/50		3N/400V/50Hz							
3/230-400/50		3/230V/50Hz - 3N/400V/50Hz							
3/220/60		3/220V/60Hz							
3/380/60		3N/380V/60Hz							
3/220-380/60		3/220V/60Hz - 3N/380V/60Hz							
3/220-400/50-60		3/220-230V/50-60Hz							
		3/380-400V/50-60Hz							
Auxiliary voltage: 230/50-60 230V/50-60Hz									
220-230/50-60 220-230V/50-60Hz									
110/50-60 110V/50-60Hz									
ID: Differential switch									
R	L	50			TC	FS1	3/230-400/50	230/50-60	
BASIC DESIGNATION					EXTENDED DESIGNATION				

Specification

STATE OF SUPPLY

RL 34 MZ – 44 MZ models

Monoblock forced draught oil burner with two stage operation, fully automatic, made up of:

- Air suction circuit **with sound proofing material**
- High performance fan with straight blades
- Air damper for air setting controlled by an adjustable hydraulic ram
- Starting motor at 2800 rpm, single-phase / 220-230V / 50-60Hz or three-phase 380-400V / 50-60Hz
- Combustion head, that can be set on the basis of required output, fitted with:
 - stainless steel end cone, resistant to corrosion and high temperatures
 - ignition electrodes
 - flame stability disk
- Exclusive patented HCS (Housing Cooling System) with high thermal insulation and air circulation with continuous air volume refresh for an active cooling system and avoid heat transfer to the electrical component housing
- Gears pump for high pressure fuel supply, fitted with:
 - filter
 - pressure regulator
 - connections for installing a pressure gauge and vacuumeter
 - internal by-pass for single pipe installation
- Valve unit with an oil safety valve and two delivery oil valves on the output circuit
- Photocell for flame detection
- Microprocessor-based burner safety control box, with diagnostic function
- Plugs and Sockets for electrical connection, accessible from the external of the cover
- Burner on/off switch
- Flame inspection window
- 1st – 2nd stage manual switch
- Slide bars for easier installation and maintenance
- Protection filter against radio interference
- IP 44 electric protection level.

Standard equipment:

- 2 flexible pipes for connection to the oil supply network
- 2 gaskets for the flexible pipes
- 2 nipples for connection to the pump
- 4 screws for fixing the burner flange to the boiler
- 1 thermal screen
- 2 Plugs for electrical connection (RL 34-44 MZ single-phase)
- 3 Plugs for electrical connection (RL 44 MZ three-phase)
- 2 slide bar extensions (for the extended head models)
- Instruction handbook for installation, use and maintenance
- Spare parts catalogue.

Specification

STATE OF SUPPLY

RL 50 – 64 MZ – 70 – 100 – 130 – 190 – 250 MZ models

Monoblock forced draught oil burner with two stage operation, fully automatic, made up of:

- Air suction circuit lined with sound-proofing material
- Fan with reverse curve blades (RL 50 – 70 – 100 – 130 models) or straight blades (RL 64 MZ – 190 – 250 MZ models)
- Air damper for air setting controlled by an adjustable hydraulic ram (or by a servomotor for the RL 250 MZ)
- Starting motor at 2800 rpm, three-phase 400V with neutral, 50Hz
- Combustion head, that can be set on the basis of required output, fitted with:
 - stainless steel end cone, resistant to corrosion and high temperatures
 - ignition electrodes
 - flame stability disk
- Gears pump for high pressure fuel supply, fitted with:
 - filter
 - pressure regulator
 - connections for installing a pressure gauge and vacuumeter
 - internal by-pass for single pipe installation
- Valve unit with an oil safety valve and two delivery oil valves on the output circuit
- Photocell for flame detection
- Microprocessor-based burner safety control box, with diagnostic function
- Burner on/off switch
- Flame inspection window
- 1st – 2nd stage manual switch
- Slide bars for easier installation and maintenance
- Protection filter against radio interference
- IP 44 electric protection level.

Standard equipment:

- 2 flexible pipes for connection to the oil supply network
- 2 gaskets for the flexible pipes
- 2 nipples for connection to the pump
- 4 screws for fixing the burner flange to the boiler
- 1 thermal screen
- Fairleads for electrical connections (RL 50 models)
- 2 slide bar extensions (for the extended head models and the RL 190 – 250 MZ models)
- Instruction handbook for installation, use and maintenance
- Spare parts catalogue.

Two Stage Light Oil Burners

RL SERIES

Available models

CODE	MODEL					HEAT OUTPUT		TOTAL ELECTRICAL POWER (kW)	NOTE
						(kW)	(kg/h)		
3470210	RL 34 MZ	TC	FS1	1/220-230/50-60	220-230/50-60	97/154-395	8,3/13-33,6	0,6	(1)
3470211	RL 34 MZ	TL	FS1	1/220-230/50-60	220-230/50-60	97/154-395	8,3/13-33,6	0,6	(1)
3470310	RL 44 MZ	TC	FS1	1/220-230/50-60	220-230/50-60	155/235-485	13/20-41	0,7	(1)
3470311	RL 44 MZ	TL	FS1	1/220-230/50-60	220-230/50-60	155/235-485	13/20-41	0,7	(1)
3470340	RL 44 MZ	TC	FS1	3/220-400/50-60	220-230/50-60	155/235-485	13/20-41	0,75	(1)
3470341	RL 44 MZ	TL	FS1	3/220-400/50-60	220-230/50-60	155/235-485	13/20-41	0,75	(1)
3474632	RL 50	TC	FS1	3/230-400/50	230/50-60	148/296-593	12,5/25-50	0,75	(1)
3474633	RL 50	TL	FS1	3/230-400/50	230/50-60	148/296-593	12,5/25-50	0,75	(1)
3474680	RL 50	TC	FS1	3/208-230/380-460/60	230/50-60	148/296-593	12,5/25-50	0,75	(1)
3474681	RL 50	TL	FS1	3/208-230/380-460/60	230/50-60	148/296-593	12,5/25-50	0,75	(1)
3470410	RL 64 MZ	TC	FS1	3/230-400/50	230/50-60	206/391-830	17,4/33-70	1,4	(1)
3470411	RL 64 MZ	TL	FS1	3/230-400/50	230/50-60	206/391-830	17,4/33-70	1,4	(1)
3475032	RL 70	TC	FS1	3/230-400/50	230/50-60	255/474-830	21,5/40-70	1,4	(2)
3475033	RL 70	TL	FS1	3/230-400/50	230/50-60	255/474-830	21,5/40-70	1,4	(2)
3475034	RL 70	TC	FS1	3/230-400/50	230/50-60	255/474-830	21,5/40-70	1,4	(1) (2)
3475035	RL 70	TL	FS1	3/230-400/50	230/50-60	255/474-830	21,5/40-70	1,4	(1) (2)
3475080	RL 70	TC	FS1	3/208-230/380-460/60	230/50-60	255/474-830	21,5/40-70	1,4	(2)
3475081	RL 70	TL	FS1	3/208-230/380-460/60	230/50-60	255/474-830	21,5/40-70	1,4	(2)
3475232	RL 100	TC	FS1	3/230-400/50	230/50-60	356/711-1186	30/60-100	1,8	(2)
3475233	RL 100	TL	FS1	3/230-400/50	230/50-60	356/711-1186	30/60-100	1,8	(2)
3475234	RL 100	TC	FS1	3/230-400/50	230/50-60	356/711-1186	30/60-100	1,8	(1) (2)
3475280	RL 100	TC	FS1	3/220/380-460/60	230/50-60	356/711-1186	30/60-100	1,8	(2)
3475281	RL 100	TL	FS1	3/220/380-460/60	230/50-60	356/711-1186	30/60-100	1,8	(2)
3475432	RL 130	TC	FS1	3/230-400/50	230/50-60	486/948-1540	41/80-130	2,6	(2)
3475433	RL 130	TL	FS1	3/230-400/50	230/50-60	486/948-1540	41/80-130	2,6	(2)
3475434	RL 130	TC	FS1	3/230-400/50	230/50-60	486/948-1540	41/80-130	2,6	(1) (2)
3475435	RL 130	TL	FS1	3/230-400/50	230/50-60	486/948-1540	41/80-130	2,6	(1) (2)
20057368	RL 130	TC	FS1	3/220/380-460/60	230/50-60	486/948-1540	41/80-130	2,6	(2)
3475481	RL 130	TL	FS1	3/220/380-460/60	230/50-60	486/948-1540	41/80-130	2,6	(2)
3475613	RL 190	TC	FS1	3/400/50	230/50-60	759/1423-2443	64/120-206	5,87	(2)
20052627	RL 190	TL	FS1	3/400/50	230/50-60	759/1423-2443	64/120-206	5,87	(2)
20011008	RL 190	TC	FS1	3/230/50	230/50-60	759/1423-2443	64/120-206	5,87	(2)
3475614	RL 190	TC	FS1	3/400/50	230/50-60	759/1423-2443	64/120-206	5,87	(1) (2)
3475680	RL 190	TC	FS1	3/460/60	220/60	759/1423-2443	64/120-206	5,87	(2)
20011009	RL 190	TC	FS1	3/220/60	220/60	759/1423-2443	64/120-206	5,87	(2)
3470010	RL 250 MZ	TC	FS1	3/230-400/50	230/50-60	600/1250-2700	51/106-228	7,2	(2)
20052629	RL 250 MZ	TL	FS1	3/400/50	230/50-60	600/1250-2700	51/106-228	7,2	(2)
20016419	RL 250 MZ	TC	FS1	3/380/60	220/60	600/1250-2700	51/106-228	7,2	(2)

(1) with plug and socket (2) with terminal board

Net calorific value: 11,8 kWh/kg - 10200 kcal/kg - Viscosity at 20°C: 4-6 mm²/s (cSt).

The burners of RL series are in according to 2014/30/EU - 2014/35/EU - 2006/42 CE Directive and EN 267 Norm.

WARNING: nozzles are supplied as accessories that must be ordered separately; please refer to the "Burner Accessories" section.

Bio fuels

Riello Burners is able to offer technical variants which allow burners to be used within environmental heating, process or special applications. These applications now include solutions for liquid Bio fuels (i.e. biodiesel and vegetable oil). Our experience in research and development and field applications with organic origin Bio fuels has resulted in Riello being able to offer a wide range of solutions for the combustion of Bio fuels.

These burner variants can be provided upon request and after a technical-commercial evaluation; for more information please contact Riello Burners Commercial and Technical Department, our Application Engineers will be pleased to help you.

Burner accessories

Nozzles



The nozzles must be ordered separately. The following table shows the features and codes on the basis of the maximum required fuel output.

NOTE: each burner needs N°2 nozzles.

BURNER	NOZZLE TYPE	GPH	RATED OUTPUT (kg/h)			NOZZLE CODE
			at 10 bar	at 12 bar	at 14 bar	
▶ RL 34 MZ	60°A	1,00	4,1	4,5	4,9	3042078
▶ RL 34 MZ	60°A	1,25	4,7	5,2	5,6	3042094
▶ RL 34 MZ	60°A	1,50	5,7	6,3	6,8	3042108
▶ RL 34 MZ	60°A	1,75	6,7	7,3	7,9	3042114
▶ RL 34 MZ	60°A	2,00	7,7	8,5	9,2	3042124
▶ RL 34 MZ	60°A	2,50	9,6	10,6	11,5	3042144
▶ RL 34 MZ	60°A	3,00	11,5	12,7	13,8	3042148
▶ RL 34 MZ	60°A	3,50	13,5	14,8	16,1	3042164
▶ RL 34 MZ	60°A	4,00	15,4	17	18,4	3042174
▶ RL 34 MZ	60°A	4,50	17,3	19,1	20,7	3042184
▶ RL 44 MZ	45°A	1,50	5,7	6,3	6,8	20011655
▶ RL 44 MZ	45°A	1,75	6,7	7,3	7,9	20011658
▶ RL 44 MZ	45°A	2,00	7,7	8,5	9,2	20011662
▶ RL 44 MZ	45°A	2,50	9,6	10,6	11,5	20011666
▶ RL 44 MZ	45°A	3,00	11,5	12,7	13,8	20011669
▶ RL 44 MZ	45°A	3,50	13,5	14,8	16,1	20011672
▶ RL 44 MZ	45°A	4,00	15,4	17	18,4	20011674
▶ RL 44 MZ	45°A	4,50	17,3	19,1	20,7	20009760
▶ RL 44 MZ	45°A	5,00	19,2	21,2	23	20011677
▶ RL 44 MZ	45°A	5,50	21,1	23,3	25,3	20011678
▶ RL 44 MZ	45°A	6,00	23,1	25,5	27,7	20011679
▶ RL 50	60°B	3,00	11,5	12,7	13,8	3042158
▶ RL 50	60°B	3,50	13,5	14,8	16,1	3042162
▶ RL 50 - 64 MZ	60°B	4,00	15,4	17	18,4	3042172
▶ RL 50 - 64 MZ	60°B	4,50	17,3	19,1	20,7	3042182
▶ RL 50 - 64 MZ - 70	60°B	5,00	19,2	21,2	23	3042192
▶ RL 50 - 64 MZ - 70	60°B	5,50	21,1	23,3	25,3	3042202
▶ RL 50 - 64 MZ - 70	60°B	6,00	23,1	25,5	27,7	3042212
▶ RL 50 - 64 MZ - 70	60°B	6,50	25	27,6	30	3042222
▶ RL 64 MZ - 70 - 100	60°B	7,00	26,9	29,7	32,3	3042232
▶ RL 64 MZ - 70 - 100	60°B	7,50	28,8	31,8	34,6	3042242
▶ RL 64 MZ - 70 - 100	60°B	8,00	30,8	33,9	36,9	3042252
▶ RL 64 MZ - 70 - 100	60°B	8,50	32,7	36,1	39,2	3042262
▶ RL 64 MZ - 70 - 100 - 130	60°B	9,50	36,5	40,3	43,8	3042282
▶ RL 64 MZ - 70 - 100 - 130 - 190	60°B	10,00	38,4	42,4	46,1	3042292
▶ RL 64 MZ - 70 - 100 - 130 - 190	60°B	11,00	42,3	46,7	50,7	3042312
▶ RL 64 MZ - 100 - 130 - 190 - 250 MZ	60°B	12,00	46,1	50,9	55,3	3042322
▶ RL 64 MZ - 100 - 130 - 190 - 250 MZ	60°B	13,00	50	55,1	59,9	3042332

To be continued in the following page

Two Stage Light Oil Burners

RL SERIES

Burner accessories

Nozzles

Continued from the previous page

BURNER	NOZZLE TYPE	GPH	RATED OUTPUT (kg/h)			NOZZLE CODE
			at 10 bar	at 12 bar	at 14 bar	
► RL 64 MZ - 100 - 130 - 190 - 250 MZ	60°B	14,00	53,8	59,4	64,5	3042352
► RL 64 MZ - 100 - 130 - 190 - 250 MZ	60°B	15,00	57,7	63,6	69,2	3042362
► RL 64 MZ - 100 - 130 - 190 - 250 MZ	60°B	16,00	61,5	67,9	73,8	3042382
► RL 64 MZ - 130 - 190 - 250 MZ	60°B	17,00	65,4	72,1	78,4	3042392
► RL 130 - 190 - 250 MZ	60°B	18,00	69,2	76,4	83	3042412
► RL 130 - 190 - 250 MZ	60°B	19,00	73	80,6	87,6	3042422
► RL 130 - 190 - 250 MZ	60°B	20,00	76,9	84,8	92,2	3042442
► RL 190 - 250 MZ	60°B	22,00	84,6	93,3	101,4	3042462
► RL 190 - 250 MZ	60°B	24,00	92,2	101,8	110,6	3042472
► RL 190 - 250 MZ	60°B	26,00	99,9	110,3	119,9	3042482
► RL 190 - 250 MZ	60°B	28,00	107,6	118,8	129,1	20018051
► RL 250 MZ	60°B	30,00	110,4	122	132,4	3042502
► RL 250 MZ	60°B	32,00	117,8	130,1	150,1	3042512
► RL 250 MZ	60°B	35,00	128,8	142,1	154,5	3042522

Extended heads

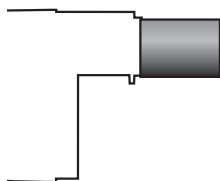

"Standard head" burners can be transformed into "extended head" versions, by using the special kit. The kits available for the various burners, giving the original and the extended lengths, are listed below.

BURNER	'STANDARD' HEAD LENGTH (mm)	'EXTENDED' HEAD LENGTH (mm)	KIT CODE
► RL 34 MZ	216	351	3010426
► RL 44 MZ	216	351	3010425
► RL 50	216	351	3010075
► RL 64 MZ	250	385	3010114
► RL 70	250	385	3010114
► RL 100	250	385	3010115
► RL 130	250	385	3010116
► RL 190	370	530	3010444 *
► RL 250 MZ	378	528	3010422

* Kit to be used on burners recognizable by a serial number that is over or equal to 02426XXXXX, for burners with a serial number that is under or equal to 02416XXXXX please use the Kit coded 3010197

Spacer kit

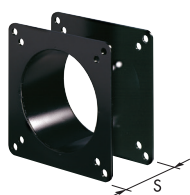

If burner head penetration into the combustion chamber needs reducing, varying thickness spacers are available, as given in the following table:

BURNER	SPACER THICKNESS S (mm)	KIT CODE
► RL 34 MZ - 44 MZ - 50	110	3010095
► RL 64 MZ - 70 - 100 - 130	135	3010129
► RL 190 - 250 MZ	102	3000722

Burner accessories

Sound proofing box

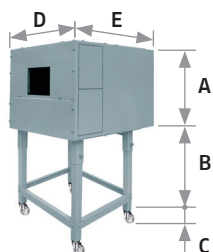

If noise emission needs reducing even further, sound-proofing boxes are available. When a lower "B" dimension is required, it is available the Box Support Kit code 20065135 which allows to reduce it at the fixed dimension of 55 mm. The sound-proofing boxes are not suitable for outdoor use.

BURNER	BOX TYPE	A (mm)	B (mm) min-max	C (mm)	D (mm)	E (mm)	[dB(A)] (*)	BOX CODE
RL 34 MZ - 44 MZ								
▶ RL 50 - 64 MZ	C1/3	650	372 - 980	110	690	770	10	3010403
RL 70 - 100 - 130								
▶ RL 190	C4/5	850	160 - 980	110	980	930	10	3010404
▶ RL 250 MZ	C7	1255	160 - 980	110	1140	1345	10	3010376

(*) Average noise reduction according to EN 15036-1 standard

Connection flange kit

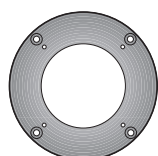

A kit is available for use where the burner opening on the boiler is of excessive diameter.

BURNER	KIT CODE
▶ RL 34 MZ - 44 MZ - 50	3010138

Degasing unit



With single pipe systems, you can find air in the oil sucked by the pump that comes from the oil itself due to negative pressure or to a faulty seal. To solve this problem, we recommend fitting a degasing unit near the burner. Two versions are available with or without filter:

BURNER	DEGASING UNIT WITH FILTER CODE (*)
▶ RL 34 MZ - 44 MZ - 50 - 64 MZ	3010055
▶ RL 70 - 100 - 130 - 190 - 250 MZ	

(*) Max capability 80 kg/h (more filters are needed for higher flow).

Volt free contact kit



A volt free contact kit is available for installation onto the burner. It can be used for a remote interface between burner operating signals. Every burner can be equipped with a single kit to remote the flame presence signal and the burner lockout indication.

BURNER	KIT CODE
▶ RL 34 MZ - 44 MZ - 64 MZ	3010419

PC interface kit



To connect the control box to a personal computer for the transmission of operation, fault signals and detailed service information, an interface adapter with PC software are available.

BURNER	KIT CODE
▶ RL 34 MZ - 44 MZ - 50 - 64 MZ - 70 - 100 - 130 - 190 - 250 MZ	3002719

Two Stage Light Oil Burners

RL SERIES

Burner accessories

Ground fault interrupter kit



A "Ground fault interrupter kit" is available as a safety device for electrical system fault.

BURNER	KIT CODE
► RL 34 MZ - 44 MZ	3010448

Post-ventilation kit

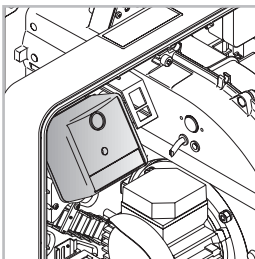

To have 20 s ventilation after opening of thermostats chain, a special kit is available.

BURNER	KIT CODE
► RL 34 MZ - 44 MZ	3010453

Hours counter kit

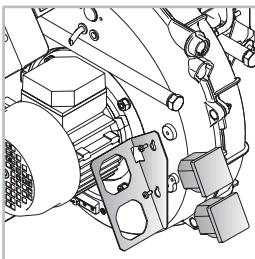

To measure the burner working time a hours counter kit is available.

BURNER	KIT CODE
► RL 34 MZ - 44 MZ	3010450

Protection kit (electromagnetic interferences)

When the burner is installed in a room particularly subject to electromagnetic interference (signals emitted over 10 V/m) due for example to INVERTER presence or in systems where the lengths of the thermostat connections is over 20 meters, this specific protection kit is available as an interface between the thermostatic controls and the burner.

BURNER	KIT CODE
► All models	3010386

Head kit for "reverse flame chamber"



In certain cases, the use of the burner on reverse flame boilers can be improved by using an additional cylinder.

BURNER	STANDARD HEAD LENGTH WITH CYLINDER (mm)	EXTENDED HEAD LENGTH WITH CYLINDER (mm)	KIT CODE
► RL 34 MZ - 44 MZ	319	429	3010178

RL/M SERIES

The RL/M series of burners covers a firing range from 166 to 2431 kW, and they have been designed for use in hot or superheater water boilers, hot air or steam generators, diathermic oil boilers.

Operation can be "two stage progressive" or, alternatively, "modulating" with the installation of a PID logic regulator and respective probes. RL/M series burners guarantees high efficiency levels in all the various applications, thus reducing fuel consumption and running costs. Optimisation of sound emissions is guaranteed by the use of fans with forward inclined blades and sound deadening material incorporated in the air suction circuit.

The exclusive design ensures reduced dimensions, simple use and maintenance. A wide range of accessories guarantees elevated working flexibility.

Guidelines for installation of burners in conformity to EU Regulation:

A RIELLO burner (Heat Generator), where it is matched with a water-based boiler (Heater Housing) with a nominal output ≤ 400 kW, providing heat for heating purposes and heat to deliver sanitary hot water, can be installed:

- With boilers (heater housings) already in service in the field, for replacement of identical products, in conformity to Article 1, paragraph 2, point (G) of the EU Regulation No. 813/2013;
- With boilers (heater housings) on a new installation.

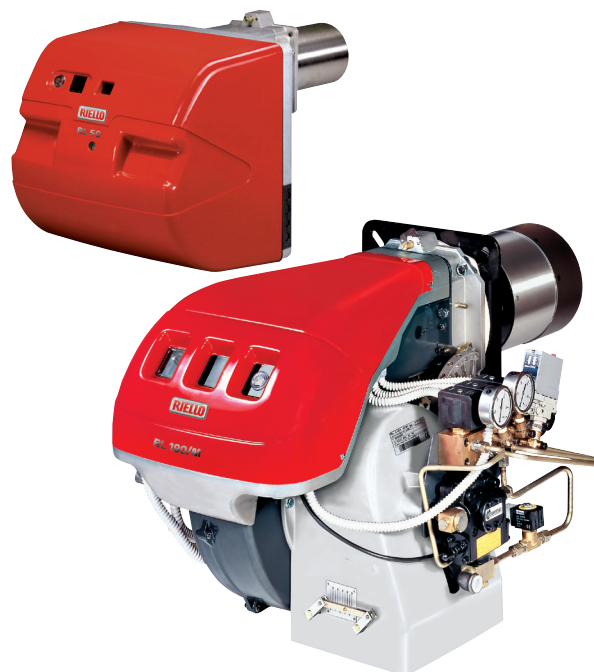

RL 28/M	90/166 ÷	332 kW
RL 38/M	101/237 ÷	450 kW
RL 50/M	130/296 ÷	593 kW
RL 70/M	261/474 ÷	1043 kW
RL 100/M	332/711 ÷	1482 kW
RL 130/M	498/948 ÷	1779 kW
RL 190/M	534/1423 ÷	2431 kW

FIRING RATES

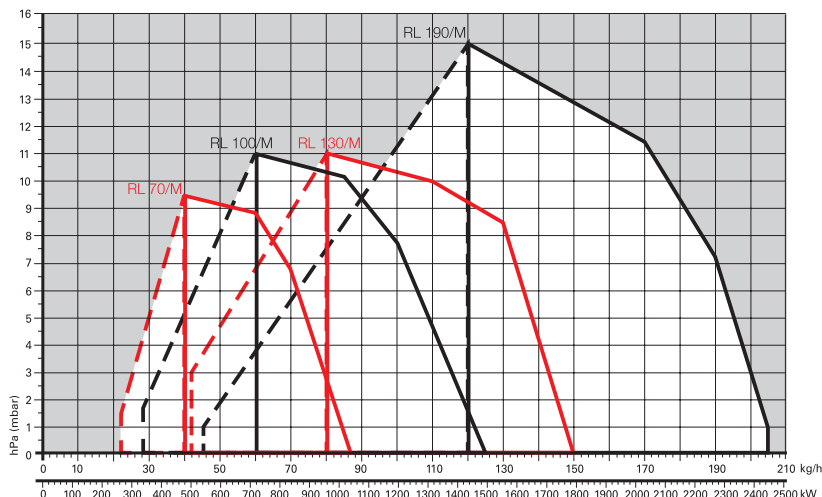
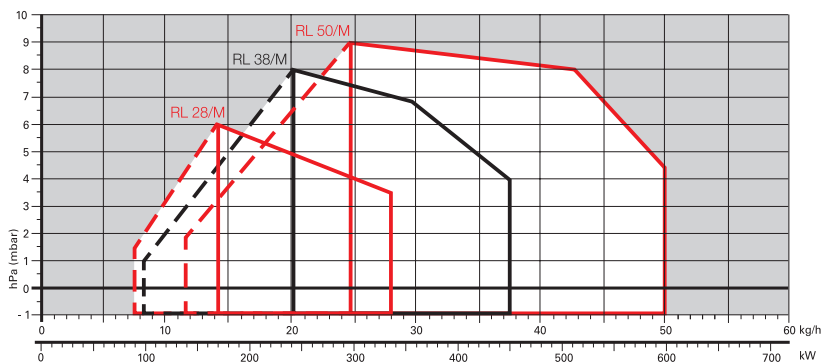

 Useful working field for choosing the burner

 Modulation range

Test conditions conforming to EN267
 Temperature: 20°C
 Pressure: 1013,5 mbar
 Altitude: 0 m a.s.l.

Modulating Light Oil Burners

RL/M SERIES

Overall dimensions (mm)

BURNER

RL 28/M - 38/M - 50/M

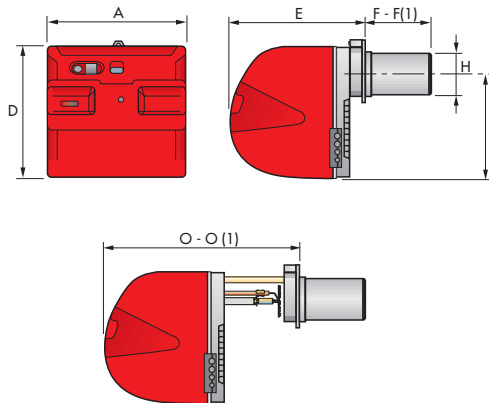

RL 70/M - 100/M - 130/M - 190/M

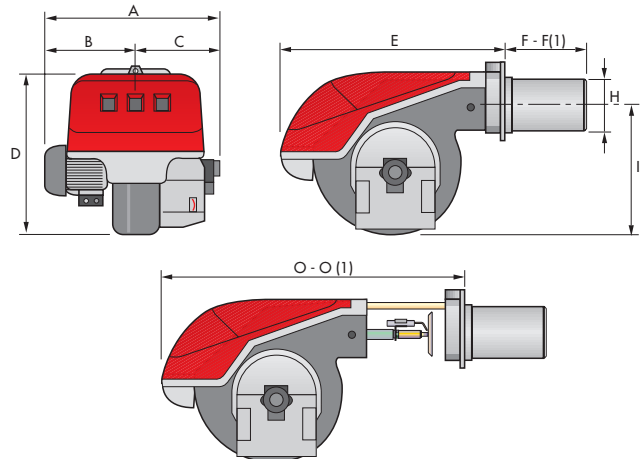

MODEL	A	B	C	D	E	F - F (1)	H	I	O - O (1)
▶ RL 28/M	476	-	-	474	468	241 - 351	140	352	672 - 807
▶ RL 38/M	476	-	-	474	468	241 - 351	140	352	672 - 807
▶ RL 50/M	476	-	-	474	468	241 - 351	152	352	672 - 807
▶ RL 70/M	663	296	367	555	680	272 - 385	179	430	951 - 1086
▶ RL 100/M	679	312	367	555	680	272 - 385	179	430	951 - 1086
▶ RL 130/M	705	338	367	555	680	272 - 385	189	430	951 - 1086
▶ RL 190/M	813	366	447	555	712	370	222	430	1166

(1) Length with extended combustion head.

BURNER - BOILER MOUNTING FLANGE

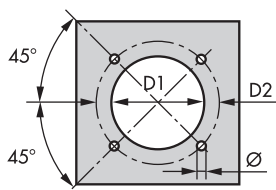

MODEL	D1	D2	Ø
▶ RL 28/M	160	224	M8
▶ RL 38/M	160	224	M8
▶ RL 50/M	160	224	M8
▶ RL 70/M	185	275 - 325	M12
▶ RL 100/M	185	275 - 325	M12
▶ RL 130/M	195	275 - 325	M12
▶ RL 190/M	230	325 - 368	M16

PACKAGING

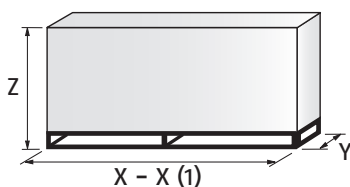

MODEL	X - X (1)	Y	Z	kg
▶ RL 28/M	872	540	550	39
▶ RL 38/M	872	540	550	41
▶ RL 50/M	872	540	550	42
▶ RL 70/M	1150	792	600	65
▶ RL 100/M	1150	792	600	68
▶ RL 130/M	1150	792	600	71
▶ RL 190/M	1200	800	850	95

(1) Length with extended combustion head.

RL/M SERIES

Specification

DESIGNATION OF SERIES

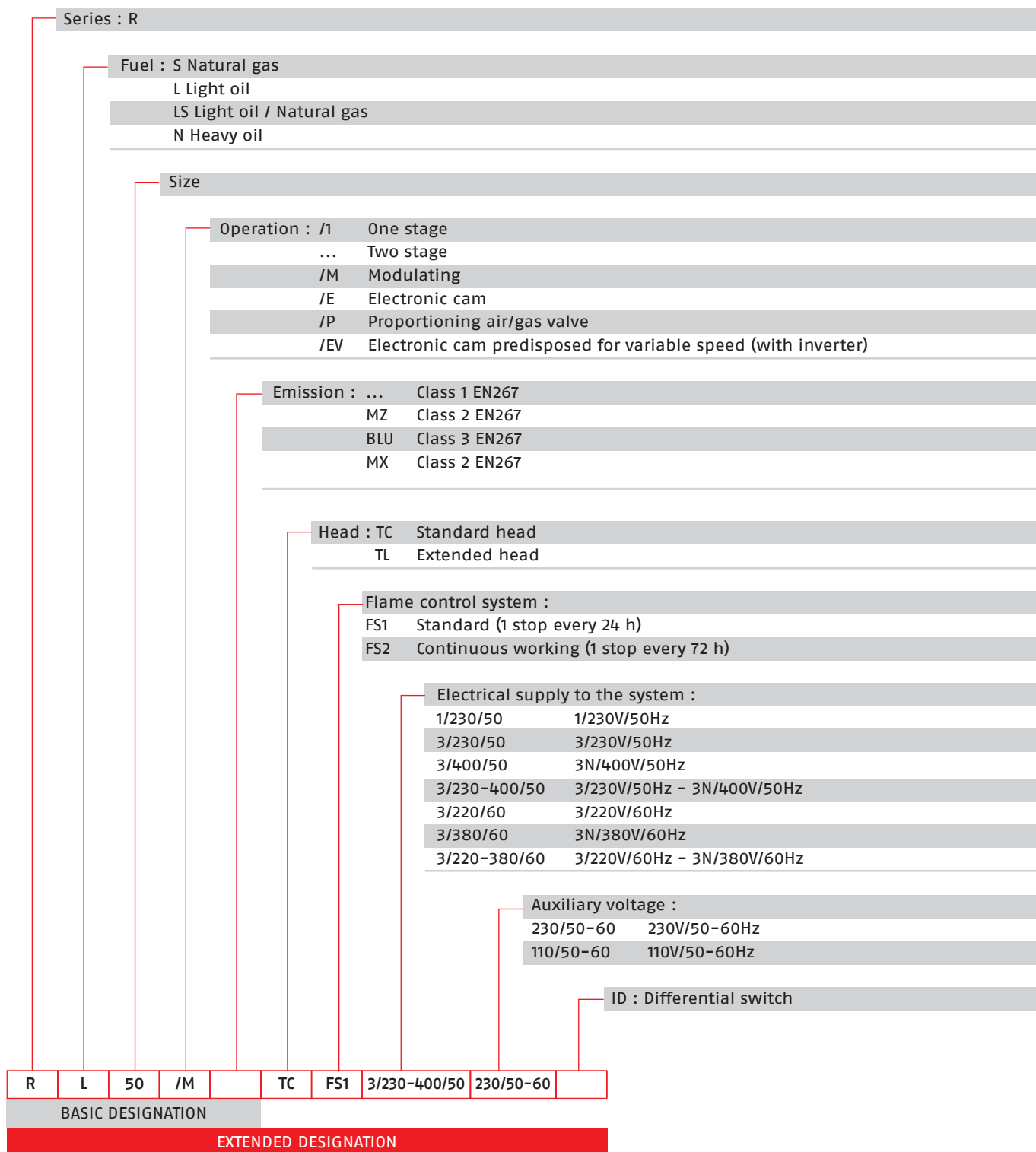

Modulating Light Oil Burners

RL/M SERIES

Specification

STATE OF SUPPLY

Monoblock forced draught oil burners, two stage progressive or modulating operation with a kit, made up of:

- Air suction circuit lined with sound-proofing material
- Fan with reverse curve blades (forward curve blades on the 190/M model)
- Air damper for air setting and automatic oil output regulator controlled by a servomotor with variable cam
- Combustion head, that can be set on the basis of required output
- Gears pump for high pressure fuel supply
- Valve unit with a double oil safety valve on the output circuit and safety valve on the return circuit; double safety valve on the return circuit for models RL 100/M, RL 130/M, RL 190/M and for all models in the TRD-72, NBN version
- Safety oil pressure switch
- Minimum oil pressure switch in the output circuit for the TRD-72, NBN versions
- Photocell for flame detection
- Burner safety control box
- Burner on/off switch
- Flame inspection window
- Manual or automatic output increase/decrease switch
- Slide bars for easier installation and maintenance
- Protection filter against radio interference
- IP 44 electric protection level.

Standard equipment:

- 2 flexible pipes for connection to the oil supply network
- 2 gaskets for the flexible pipes
- 2 nipples for connection to the pump
- 4 screws for fixing the burner flange to the boiler
- 1 thermal screen
- Wiring loom fittings for electrical connections
- 2 slide bar extensions (for the extended head models and the RL 190/M model)
- Instruction handbook for installation, use and maintenance
- Spare parts catalogue.

Available models

Burners

CODE	MODEL					HEAT OUTPUT		TOTAL ELECTRICAL POWER (kW)	NOTE
						(kW)	(kg/h)		
20166492	RL 28/M	TC	FS1	1/230/50	230/50-60	90/166-332	7,5/14-28	0,4	(1)
20166495	RL 28/M	TL	FS1	1/230/50	230/50-60	90/166-332	7,5/14-28	0,4	(1)
20167453	RL 28/M	TC	FS1	1/220-230/60	230/50-60	90/166-332	7,5/14-28	0,4	(1)
20166497	RL 38/M	TC	FS1	3/230-400/50	230/50-60	101/237-450	8,5/20-38	0,6	(1)
20166499	RL 38/M	TL	FS1	3/230-400/50	230/50-60	101/237-450	8,5/20-38	0,6	(1)
20167456	RL 38/M	TC	FS1	3/208-230/380-460/60	230/50-60	101/237-450	8,5/20-38	0,66	(1)
20166502	RL 50/M	TC	FS1	3/230-400/50	230/50-60	130/296-593	11/25-50	0,8	(1)
20166504	RL 50/M	TL	FS1	3/230-400/50	230/50-60	130/296-593	11/25-50	0,8	(1)
20167458	RL 50/M	TC	FS1	3/208-230/380-460/60	230/50-60	130/296-593	11/25-50	0,66	(1)

RL/M SERIES

Available models

Burners

CODE	MODEL					HEAT OUTPUT		TOTAL ELECTRICAL POWER (kW)	NOTE
						(kW)	(kg/h)		
20166463	RL 70/M	TC	FS1	3/230-400/50	230/50-60	261/474-1043	22/40-88	1,4	(1)
20166476	RL 70/M	TL	FS1	3/230-400/50	230/50-60	261/474-1043	22/40-88	1,4	(1)
20166481	RL 100/M	TC	FS1	3/230-400/50	230/50-60	332/711-1482	28/60-125	2,1	(1)
20166484	RL 100/M	TL	FS1	3/230-400/50	230/50-60	332/711-1482	28/60-125	2,1	(1)
20167439	RL 100/M	TC	FS1	3/220/380-460/60	230/50-60	332/711-1482	28/60-125	2,1	(1)
20167440	RL 100/M	TL	FS1	3/220/380-460/60	230/50-60	332/711-1482	28/60-125	2,1	(1)
20166486	RL 130/M	TC	FS1	3/230-400/50	230/50-60	498/948-1779	42/80-150	2,6	(1)
20166487	RL 130/M	TL	FS1	3/230-400/50	230/50-60	498/948-1779	42/80-150	2,6	(1)
20167441	RL 130/M	TL	FS1	3/220/380-460/60	230/50-60	498/948-1779	42/80-150	2,6	(1)
20166490	RL 190/M	TC	FS1	3/400/50	230/50-60	534/1423-2431	45/120-205	5,5	(1)
20166488	RL 190/M	TC	FS1	3/230/50	230/50-60	534/1423-2431	45/120-205	5,5	(1)
20169222	RL 190/M	TC	FS1	3/460/60	220/60	534/1423-2431	45/120-205	5,5	(1)
20169231	RL 190/M	TL	FS1	3/400/50	230/50-60	534/1423-2431	45/120-205	5,5	(1)

Net calorific value: 11,8 kWh/kg - 10200 kcal/kg - Viscosity at 20°C: 4-6 mm²/s (cSt).

The burners of RL/M series are in according to 2014/30/EU - 2014/35/EU - 2006/42 EC Directive and EN 267.

(1) with RFGO control box

Due to the improvement applied on the technical specification of some products, some burner codes will change during year 2019. The table below summarizes the correspondence between the previous and the new code.

MODEL		NEW CODE	OLD CODE
RL 28/M	TC FS1 1/230/50	20166492 (1)	3471002
RL 28/M	TL FS1 1/230/50	20166495 (1)	3471003
RL 28/M	TC FS1 1/220-230/60	20167453 (1)	3471080
RL 38/M	TC FS1 3/230-400/50	20166497 (1)	3471402
RL 38/M	TL FS1 3/230-400/50	20166499 (1)	3471403
RL 38/M	TC FS1 3/208-230/380-460/60	20167456 (1)	3471480
RL 50/M	TC FS1 3/230-400/50	20166502 (1)	3471602
RL 50/M	TL FS1 3/230-400/50	20166504 (1)	3471603
RL 50/M	TC FS1 3/208-230/380-460/60	20167458 (1)	3471680
RL 70/M	TC FS1 3/230-400/50	20166463 (1)	3477012
RL 70/M	TL FS1 3/230-400/50	20166476 (1)	3477013
RL 100/M	TC FS1 3/230-400/50	20166481 (1)	3477212
RL 100/M	TL FS1 3/230-400/50	20166484 (1)	3477213
RL 100/M	TC FS1 3/220/380-460/60	20167439 (1)	3477280
RL 100/M	TL FS1 3/220/380-460/60	20167440 (1)	3477281
RL 130/M	TC FS1 3/230-400/50	20166486 (1)	3477412
RL 130/M	TL FS1 3/230-400/50	20166487 (1)	3477413
RL 130/M	TL FS1 3/220/380-460/60	20167441 (1)	3477481
RL 190/M	TC FS1 3/400/50	20166490 (1)	3477811
RL 190/M	TC FS1 3/230/50	20166488 (1)	20011022
RL 190/M	TC FS1 3/460/60	20169222 (1)	3477880
RL 190/M	TL FS1 3/400/50	20169231 (1)	20052628

Burner accessories

Return nozzles type A3, A4 45°

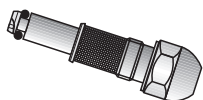

The following list shows the features and codes on the basis of the maximum required fuel output.

NOTE: each burner needs N° 1 nozzle.

BURNER	RATED OUTPUT kg/h	A3 NOZZLE CODE	A4 NOZZLE CODE
▶ RL 28/M	15	3009850	-
▶ RL 28/M - 38/M	20	3009851	-
▶ RL 28/M - 38/M - 50/M	30	3009852	-
▶ RL 38/M - 50/M - 70/M	40	3009853	20067277
▶ RL 50/M - 70/M	50	3009854	20067279
▶ RL 70/M - 100/M	60	3009855	20067281
▶ RL 70/M - 100/M	70	3009856	20067283
▶ RL 100/M - 130/M	80	3009857	20067284
▶ RL 100/M - 130/M	90	3009858	20067285
▶ RL 100/M - 130/M	100	3009859	20067286
▶ RL 130/M	110	3009860	20067287
▶ RL 130/M - 190/M	120	3009861	20067288
▶ RL 130/M - 190/M	130	3009862	20067289
▶ RL 190/M	140	3009863	20067290
▶ RL 190/M	150	20059496*	20067291
▶ RL 190/M	160	3009864	20067293
▶ RL 190/M	180	3009865	20067295
▶ RL 190/M	200	3009866	20067297

* 60° Angle

Extended head kit

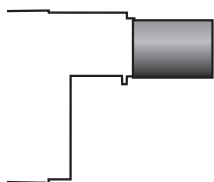

"Standard head" burners can be transformed into "extended head" versions, by using the special kit.

BURNER	STANDARD HEAD LENGTH (mm)	EXTENDED HEAD LENGTH (mm)	KIT CODE
▶ RL 28/M	241	351	3010120
▶ RL 38/M	241	351	3010121
▶ RL 50/M	241	351	3010122
▶ RL 70/M	272	385	3010159
▶ RL 100/M	272	385	3010160
▶ RL 130/M	272	385	3010161
▶ RL 190/M	370	526	20058084

Spacer kit

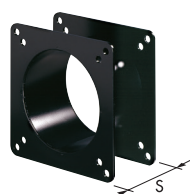

If burner head penetration into the combustion chamber needs reducing, varying thickness spacers are available, as given in the following list.

BURNER	SPACER THICKNESS S (mm)	KIT CODE
▶ RL 28/M - 38/M - 50/M	110	3010095
▶ RL 70/M - 100/M - 130/M	135	3010129
▶ RL 190/M	102	3000722

RL/M SERIES

Burner accessories

Sound proofing box

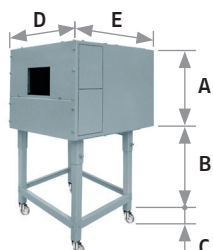

If noise emission needs reducing even further, sound-proofing boxes are available. When a lower "B" dimension is required, it is available the Box Support Kit code 20065135 which allows to reduce it at the fixed dimension of 55 mm. The sound-proofing boxes are not suitable for outdoor use.

BURNER	BOX TYPE	A (mm)	B (mm) min-max	C (mm)	D (mm)	E (mm)	[dB(A)] (*)	BOX CODE
▶ RL 28/M - 38/M - 50/M	C1/3	650	372 - 980	110	690	770	10	3010403
▶ RL 70/M - 100/M - 130/M	C4/5	850	160 - 980	110	980	930	10	3010404

(*) Average noise reduction according to EN 15036-1 standard

Degasing unit



To solve problem of air in the oil sucked, two versions of degasing unit are available.

BURNER	FILTER	FILTERING DEGREE (µm)	DEGASING UNIT CODE (*)
▶ RL 28/M - 38/M - 50/M - 70/M - 100/M	With filter	50 - 75	3010055

(*) Max capability 80 kg/h (more filters are needed for higher flow).

Head kit for "reverse flame chamber"



In certain cases, the use of the burner on reverse flame boilers can be improved by using an additional cylinder.

BURNER	STANDARD HEAD LENGTH WITH CYLINDER (mm)	EXTENDED HEAD LENGTH WITH CYLINDER (mm)	KIT CODE (*)
▶ RL 28/M - 38/M	319	429	3010178
▶ RL 50/M	319	429	3010179
▶ RL 70/M - 100/M	375	488	3010180
▶ RL 130/M	375	488	3010183
▶ RL 190/M	493	-	3010241

(*) CE approval on field is required

Connection flange kit

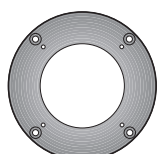

A kit is available for use where the burner opening on the boiler is of excessive diameter.

BURNER	KIT CODE
▶ RL 28/M - 38/M - 50/M	3010138

Modulating Light Oil Burners

RL/M SERIES

Burner accessories

Accessories for modulating operation



To obtain modulating operation, the RL/M series of burners requires a regulator. For remote setpoint use RWF 55.

BURNER	REGULATOR TYPE	REGULATOR CODE
▶ RL 28/M - 38/M - 50/M	RWF 50.2	20082208
▶ RL 70/M - 100/M - 130/M - 190/M	RWF 55.5	20099657



The relative temperature or pressure probes fitted to the regulator, must be chosen on the basis of the application.

BURNER	PROBE TYPE	RANGE (°C) (bar)	PROBE CODE
	Temperature PT 100	-100 ÷ 500°C	3010110
▶ RL 28/M - 38/M - 50/M	Pressure 4 ÷ 20 mA	0 ÷ 2,5 bar	3010213
▶ RL 70/M - 100/M - 130/M - 190/M	Pressure 4 ÷ 20 mA	0 ÷ 16 bar	3010214
	Pressure 4 ÷ 20 mA	0 ÷ 25 bar	3090873

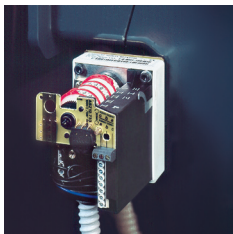

Depending on the servomotor fitted to the burner, a three-pole potentiometer (1000 Ω) can be installed to check the position of the servomotor.

BURNER	POTENTIOMETER KIT CODE
▶ RL 28/M - 38/M - 50/M	3010109
▶ RL 70/M - 100/M - 130/M - 190/M	3010416

PRESS GV SERIES

The PRESS G series of burners covers a firing range from 140 to 356 kW and they have been designed for use in civil installations of small dimensions or in industrial applications, like incinerators or dyer kilns. Operation is "One stage"; the burners are fitted with a microprocessor-based burner safety control box which supplies indication of operation and diagnosis of fault cause. The combustion head, that can be set on the basis of required output, allows optimal performance ensuring good combustion and reducing fuel consumption. The main feature of these burners is their reliability due to a simple and strong construction, which permits operation without particular maintenance intervention. Simplified maintenance is achieved by the slide bar system, which allows easy access to all of the essential components of the combustion head. All electrical components are easily accessible only by dismounting a protection panel, thus guaranteeing a quick and simple intervention on components.

Guidelines for installation of burners in conformity to EU Regulation:

A RIELLO burner (Heat Generator), where it is matched with a water-based boiler (Heater Housing) with a nominal output ≤ 400 kW, providing heat for heating purposes and heat to deliver sanitary hot water, can be installed:

- With boilers (heater housings) already in service in the field, for replacement of identical products, in conformity to Article 1, paragraph 2, point (G) of the EU Regulation No. 813/2013;
- With boilers (heater housings) on a new installation.

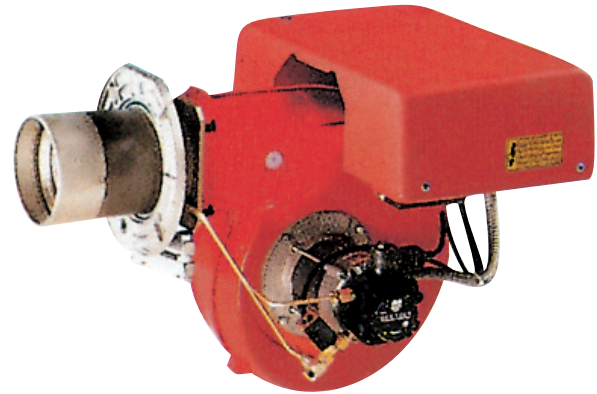

PRESS G24	140 ÷ 237 kW
PRESS GV	178 ÷ 356 kW

FIRING RATES

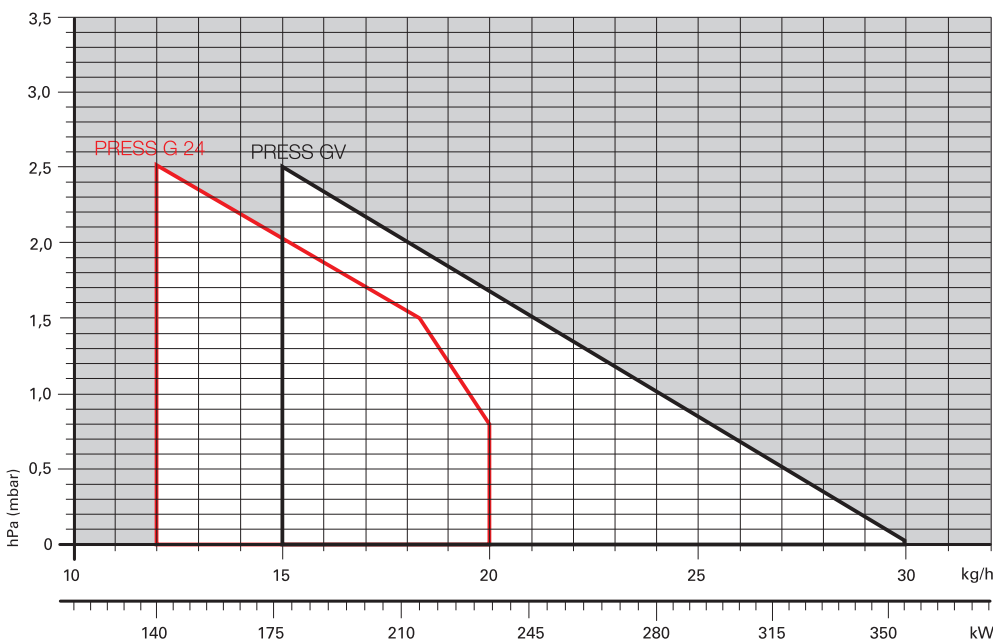

Useful working field for choosing the burner

Test conditions conforming to EN267
 Temperature: 20°C
 Pressure: 1013,5 mbar
 Altitude: 0 m a.s.l.

One Stage Light Oil Burners

PRESS GV SERIES

Overall dimensions (mm)

BURNER

PRESS G24

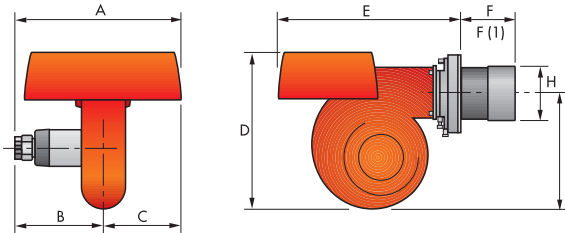

PRESS GV

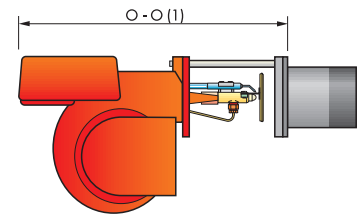
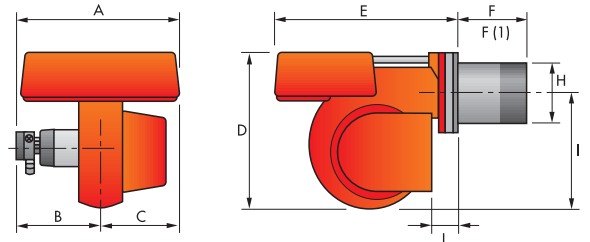

MODEL	A	B	C	D	E	F - F (1)	H	I	L	O - O (1)
► PRESS G24	425	222	203	397	485	118 - 253	125	290	-	- - -
► PRESS GV	439	234	205	397	473	185 - 320	140	292	59	690 - 825

(1) Length with extended combustion head.

BURNER - BOILER MOUNTING FLANGE

PRESS G24

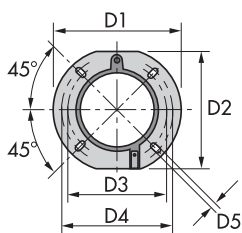

PRESS GV

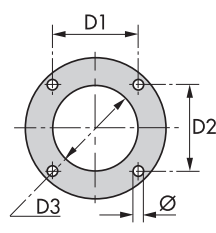

MODEL	D1	D2	D3	D4	D5	Ø
PRESS G24	213	198	160	190	11	-
PRESS GV	160	160	170	-	-	M10

PACKAGING

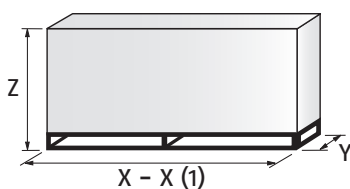

MODEL	X - X (1)	Y	Z	kg
► PRESS G24	650	535	450	33
► PRESS GV	680	535	450	33

(1) Length with extended combustion head.

PRESS GV SERIES

Specification

DESIGNATION OF SERIES

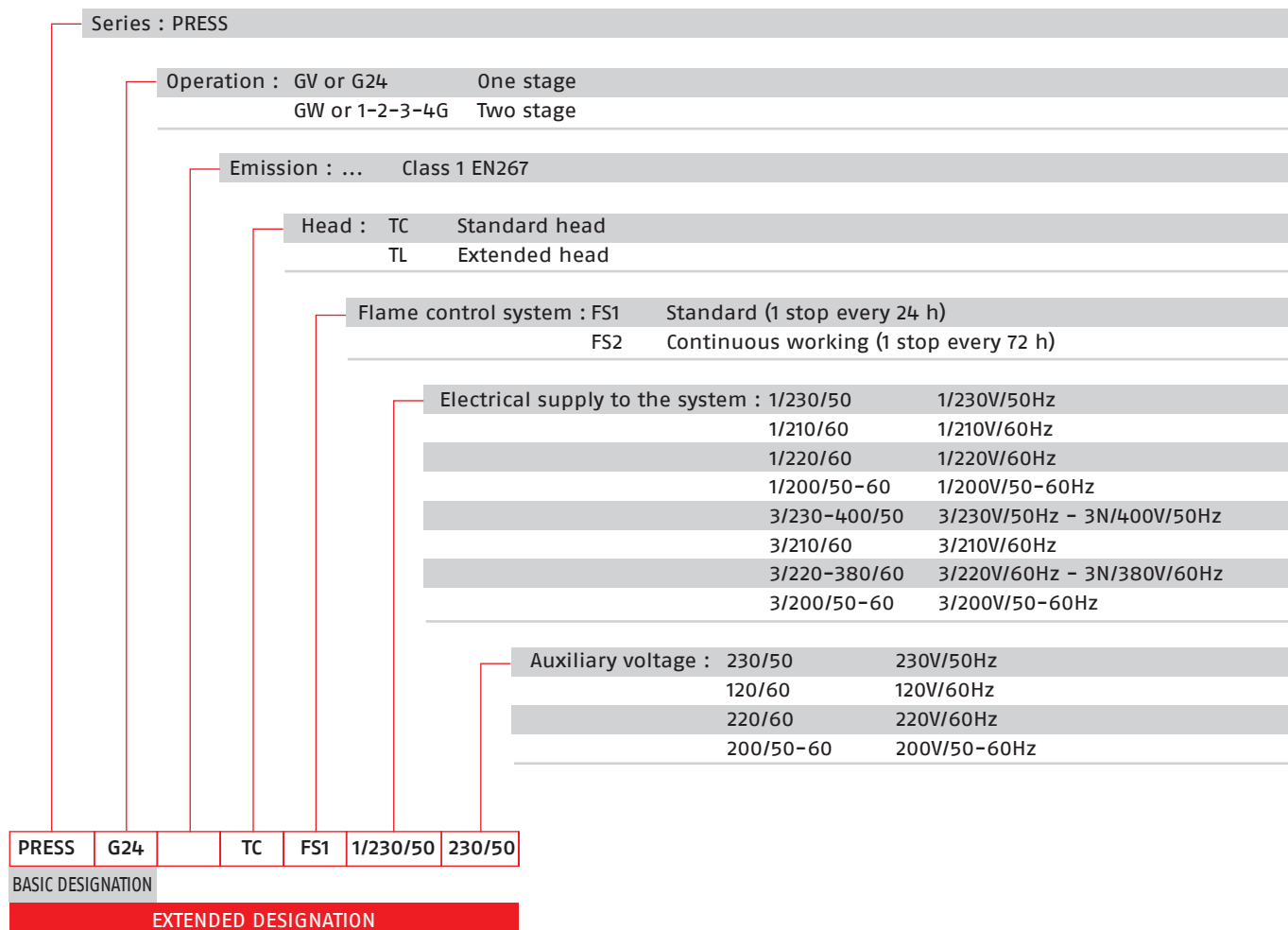

One Stage Light Oil Burners

PRESS GV SERIES

Specification

STATE OF SUPPLY

Monoblock forced draught oil burner with one stage operation, fully automatic, made up of:

- Air suction circuit
- Fan with forward curve blades with high performance concerning pressure and air delivery
- Air damper for air setting
- Starting motor at 2850 rpm, single-phase, 230V, 50Hz
- Combustion head, that can be set on the basis of required output, fitted with:
 - stainless steel end cone, resistant to corrosion and high temperatures
 - ignition electrodes
 - flame stability disk
- Gears pump for high pressure fuel supply, fitted with:
 - filter
 - pressure regulator
 - connections for installing a pressure gauge and vacuumeter
 - internal by-pass for single pipe installation
- Oil valves on the output circuit
- Photocell for flame detection
- Microprocessor-based burner safety control box, with diagnostic function
- Slide bars for easier installation and maintenance (for GV model)
- Protection filter against radio interference
- IP 44 electric protection level.

Standard equipment:

- 2 flexible pipes for connection to the oil supply network
- 2 gaskets for the flexible pipes
- 2 nipples for connection to the pump
- 2 Pipe fittings (for GV model)
- 2 Pipe fittings gasket (for GV model)
- 1 burner flange (for G24 model)
- 4 screws for fixing the burner flange to the boiler
- 1 thermal screen
- Instruction handbook for installation, use and maintenance
- Spare parts catalogue.

Available models

CODE	MODEL					HEAT OUTPUT		TOTAL ELECTRICAL POWER (kW)	NOTE
						(kW)	(kg/h)		
20096861	PRESS G24	TC	FS1	1/230/50	230/50	140/237	12/20	0,4	(1)
3473620	PRESS GV	TC	FS1	1/230/50	230/50	178/356	15/30	0,43	(1)
3808058	PRESS GV	TC	FS1	1/220/60	220/60	178/356	15/30	0,43	(1)

Net calorific value: 11,8 kWh/kg – 10200 kcal/kg – Viscosity at 20°C 4–6 mm²/s (cSt)

The burners of PRESS series are in according to 2014/30/EU – 2014/35/EU – 2006/42 EC Directive and EN 267.

(1) Burner needs 1 nozzle (to order separately).

Burner accessories

Nozzles type 60°B



The nozzles must be ordered separately. The following table shows the features and codes on the basis of the maximum required fuel output.

NOTE : for nozzles quantity to order see note in the "Available Burner Models" table.

BURNER	RATED DELIVERY [kg/h] at 12 bar	GPH	NOZZLE CODE
▶ PRESS G24	6,3	1,50	3042107
▶ PRESS G24	7,3	1,75	3042110
▶ PRESS G24	8,5	2,00	3042126
▶ PRESS G24	10,6	2,50	3042140
▶ PRESS G24	12,7	3,00	3042158
▶ PRESS G24	14,8	3,50	3042162
▶ PRESS GV	17	4,00	3042172
▶ PRESS GV	19,1	4,50	3042182
▶ PRESS GV	21,2	5,00	3042192
▶ PRESS GV	23,3	5,50	3042202
▶ PRESS GV	25,5	6,00	3042212
▶ PRESS GV	27,6	6,50	3042222
▶ PRESS GV	29,7	7,00	3042232
▶ PRESS GV	31,8	7,50	3042242

Extended head kit

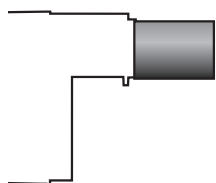

"Standard head" burners can be transformed into "extended head" versions, by using the special kit.

BURNER	STANDARD HEAD LENGTH (mm)	EXTENDED HEAD LENGTH (mm)	KIT CODE
▶ PRESS GV	185	320	3000580

Spacer kit

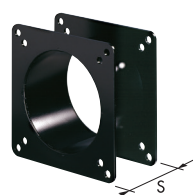

If burner head penetration into the combustion chamber needs reducing, varying thickness spacers are available, as given in the following list.

BURNER	SPACER THICKNESS S (mm)	KIT CODE
▶ PRESS GV	142	3000755

One Stage Light Oil Burners

PRESS GV SERIES

Burner accessories

Sound proofing box

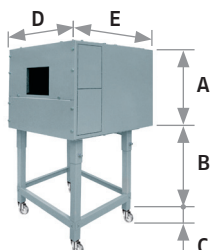

If noise emission needs reducing even further, sound-proofing boxes are available. When a lower "B" dimension is required, it is available the Box Support Kit code 20065135 which allows to reduce it at the fixed dimension of 55 mm. The sound-proofing boxes are not suitable for outdoor use.

BURNER	BOX TYPE	A (mm)	B (mm) min-max	C (mm)	D (mm)	E (mm)	[dB(A)] (*)	BOX CODE
► PRESS GV	C1/3	650	372 - 980	110	690	770	10	3010403

(*) Average noise reduction according to EN 15036-1 standard

Degasing unit



To solve problem of air in the oil sucked, two versions of degasing unit are available.

BURNER	FILTER	FILTERING DEGREE (µm)	DEGASING UNIT CODE
► PRESS GV	With filter	50 - 75	3010055

PC Interface kit



To connect the control box to a personal computer for the transmission of operation, fault signals and detailed service information, an interface adapter with PC software are available.

BURNER	KIT CODE
► PRESS G24 - GV	3002719

Protection kit (electromagnetic interferences)

When the burner is installed in a room particularly subject to electromagnetic interference (signals emitted over 10 V/m) due for example to INVERTER presence or in systems where the lengths of the thermostat connections is over 20 meters, this specific protection kit is available as an interface between the thermostatic controls and the burner.

BURNER	KIT CODE
► All models	3010386

PRESS G SERIES

The PRESS G series of burners covers a firing range from 107 to 1660 kW and they have been designed for use in civil installations of average dimensions, like building areas and large apartment groups or for use in industrial applications, like small or medium plants.

Operation is two stage; the burners are fitted with a microprocessor-based burner safety control box which supplies indication of operation and diagnosis of fault cause. The combustion head, that can be set on the basis of required output, allows optimal performance ensuring good combustion and reducing fuel consumption. The main feature of these burners is their reliability due to a simple and strong construction, that permits operation without particular maintenance intervention.

Simplified maintenance is achieved by the slide bar system, which allows easy access to all of the essential components of the combustion head. All electrical components are easily accessible only by dismounting a protection panel, thus guaranteeing a quick and simple intervention on components.

Guidelines for installation of burners in conformity to EU Regulation:

A RIELLO burner (Heat Generator), where it is matched with a water-based boiler (Heater Housing) with a nominal output ≤ 400 kW, providing heat for heating purposes and heat to deliver sanitary hot water, can be installed:

- With boilers (heater housings) already in service in the field, for replacement of identical products, in conformity to Article 1, paragraph 2, point (G) of the EU Regulation No. 813/2013;
- With boilers (heater housings) on a new installation.

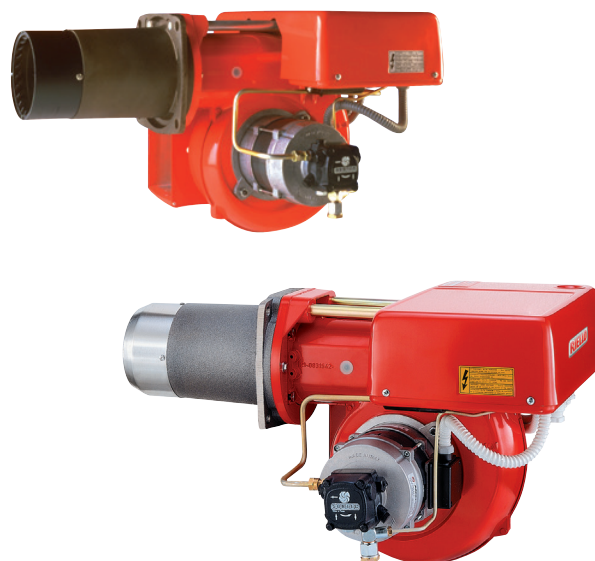

PRESS GW	107/178 ÷	356 kW
PRESS 1G	130/190 ÷	534 kW
PRESS 2G	214/356 ÷	712 kW
PRESS 3G	273/534 ÷	1168 kW
PRESS 4G	415/830 ÷	1660 kW

FIRING RATES

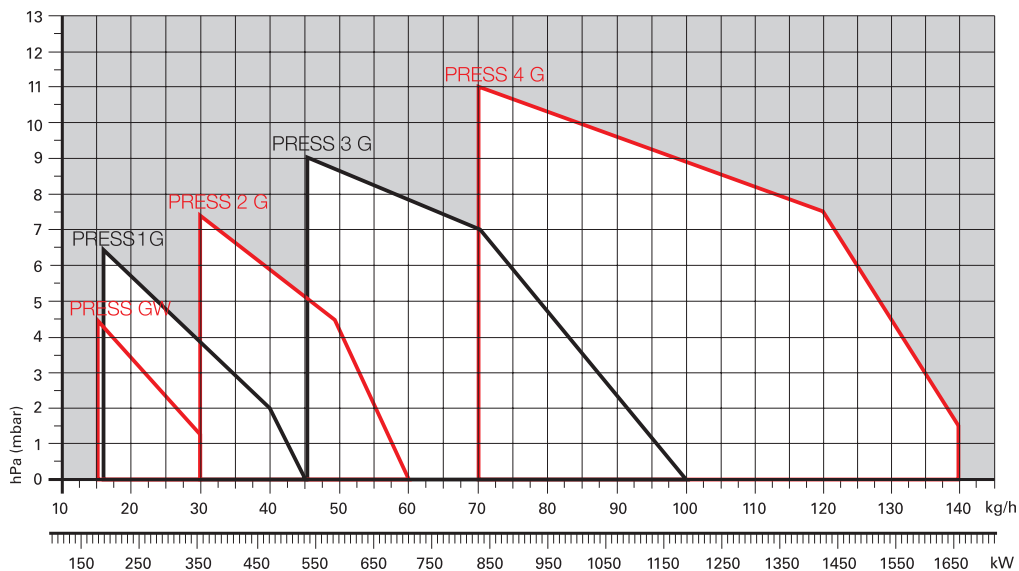

Useful working field for choosing the burner

Test conditions conforming to EN267
 Temperature: 20°C
 Pressure: 1013,5 mbar
 Altitude: 0 m a.s.l.

Two Stage Light Oil Burners

PRESS G SERIES

Overall dimensions (mm)

BURNER

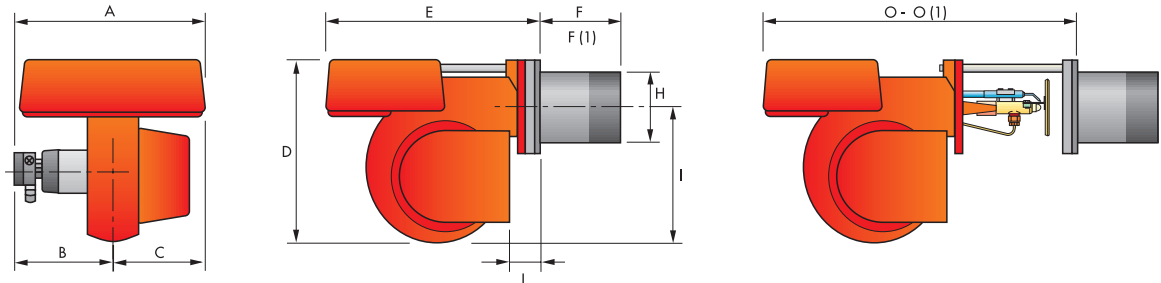

MODEL	A	B	C	D	E	F -	F (1)	H	I	L	O -	O (1)
▶ PRESS GW	439	234	205	397	473	185 -	320	140	292	59	745 -	880
▶ PRESS 1G	475	270	205	397	473	236 -	370	150	292	59	745 -	880
▶ PRESS 2G	475	270	205	437	506	237 -	403	155	332	89	785 -	945
▶ PRESS 3G	611	406	205	485	570	227 -	412	175	370	88	846 -	1006
▶ PRESS 4G	675	354	316	590	720	266 -	426	205	445	175	999 -	1159

(1) Length with extended combustion head.

BURNER - BOILER MOUNTING FLANGE

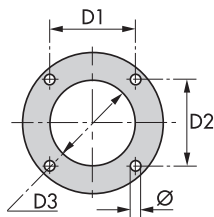

MODEL	D1	D2	D3	Ø
▶ PRESS GW	160	160	155	M10
▶ PRESS 1G	160	160	165	M10
▶ PRESS 2G	160	160	165	M10
▶ PRESS 3G	195	195	185	M12
▶ PRESS 4G	230	230	210	M12

PACKAGING

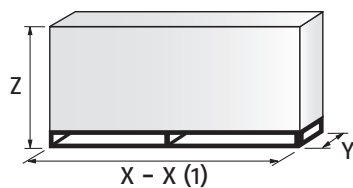

MODEL	X - X (1)	Y	Z	kg
▶ PRESS GW	695	542	468	37
▶ PRESS 1G	745	542	468	44
▶ PRESS 2G	800	542	515	44
▶ PRESS 3G	1000	790	550	55
▶ PRESS 4G	1200	790	650	95

(1) Length with extended combustion head.

Specification

DESIGNATION OF SERIES

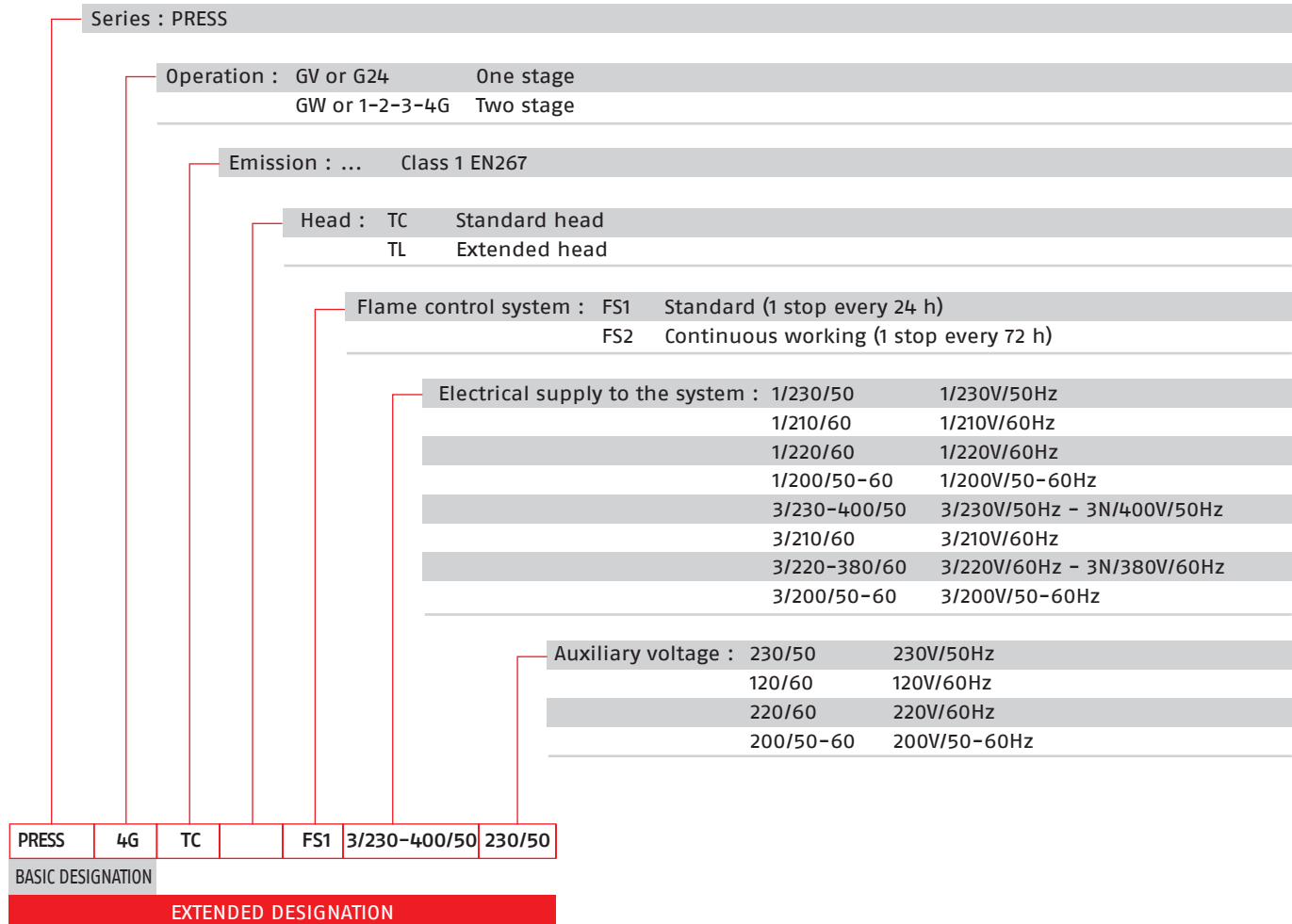

Two Stage Light Oil Burners

PRESS G SERIES

Specification

STATE OF SUPPLY

Monoblock forced draught oil burner with two stage operation, fully automatic, made up of:

- Air suction circuit lined with sound-proofing material
- Fan with forward curve blades with high performance concerning pressure and air delivery
- Air damper for air setting
- Hydraulic ram for air damper control
- Starting motor at 2800 rpm, three-phase 400V with neutral, 50Hz (single-phase, 230V and 50Hz for the PRESS GW model)
- Combustion head, that can be set on the basis of required output, fitted with:
 - stainless steel end cone, resistant to corrosion and high temperatures
 - ignition electrodes
 - flame stability disk
- Fan pressure test point
- Gears pump for high pressure fuel supply, fitted with:
 - filter
 - pressure regulator
 - connections for installing a pressure gauge and vacuumeter
 - internal by-pass for single pipe installation
- Valve unit with two delivery oil valves on the output circuit
- Photocell for flame detection
- Microprocessor-based burner safety control box, with diagnostic function
- Slide bars for easier installation and maintenance
- Protection filter against radio interference
- IP 44 electric protection level.

Standard equipment:

- 2 flexible pipes for connection to the oil supply network
- 2 gaskets for the flexible pipes
- 2 nipples for connection to the pump
- 4 screws for fixing the burner flange to the boiler
- 1 thermal screen
- Instruction handbook for installation, use and maintenance
- Spare parts catalogue.

Two Stage Light Oil Burners

PRESS G SERIES

RIELLO

Available models

CODE	MODEL					HEAT OUTPUT		TOTAL ELECTRICAL POWER (kW)	NOTE
						(kW)	(kg/h)		
20032930	PRESS GBW	TC	FS1	1/230/50	230/50	107/178-356	9/15-30	0,43	(1)(2)
3473787	PRESS GW	TC	FS1	1/200/50-60	200/50-60	107/178-356	9/15-30	0,6	(1)
3473784	PRESS GW	TC	FS1	1/220/60	220/60	107/178-356	9/15-30	0,4	(1)
3473720	PRESS GW	TC	FS1	1/230/50	230/50	107/178-356	9/15-30	0,43	(1)
3474587	PRESS 1G	TC	FS1	3/200/50-60	200/50-60	130/190-534	11/16-45	0,6	(1)
3474582	PRESS 1G	TC	FS1	3/220-380/60	220/60	130/190-534	11/16-45	0,6	(1)
3474520	PRESS 1G	TC	FS1	3/230-400/50	230/50	130/190-534	11/16-45	0,6	(1)
3474987	PRESS 2G	TC	FS1	3/200/50-60	200/50-60	214/356-712	18/30-60	0,85	(1)
3474982	PRESS 2G	TC	FS1	3/220-380/60	220/60	214/356-712	18/30-60	0,85	(1)
3474920	PRESS 2G	TC	FS1	3/230-400/50	230/50	214/356-712	18/30-60	1,1	(1)
3475987	PRESS 3G	TC	FS1	3/200/50-60	200/50-60	273/534-1186	23/45-100	2,05	(1)
3475982	PRESS 3G	TC	FS1	3/220-380/60	220/60	273/534-1186	23/45-100	2,05	(1)
3475920	PRESS 3G	TC	FS1	3/230-400/50	230/50	273/534-1186	23/45-100	2,05	(1)
3476582	PRESS 4G	TC	FS1	3/220-380/60	220/60	415/830-1660	35/70-140	3,8	(1)
3476520	PRESS 4G	TC	FS1	3/230-400/50	230/50	415/830-1660	35/70-140	3,8	(1)

(1) Air damper open during stop

(2) Suitable for operation with Gasoil and Blends of gasoil and bio fuel (FAME in accordance with EN 14214) up to 10%

Net calorific value: 11,8 kWh/kg - 10200 kcal/kg - Viscosity at 20°C: 4±6 mm²/s (cSt)

The burners of PRESS series are in accordance to 2014/30/EU - 2014/35/EU - 2006/42 EC Directive and EN 267.

Two Stage Light Oil Burners

PRESS G SERIES

Burner accessories

Nozzles type 60°B



The nozzles must be ordered separately. The following table shows the features and codes on the basis of the maximum required fuel output.

NOTE: each burner is equipped with N° 2 nozzles.

BURNER	RATED DELIVERY [kg/h] at 12 bar	GPH	NOZZLE CODE
▶ PRESS GW – 1G	8,5	2,00	3042126
▶ PRESS GW – 1G	10,6	2,50	3042140
▶ PRESS GW – 1G	12,7	3,00	3042158
▶ PRESS GW – 1G	14,8	3,50	3042162
▶ PRESS GW – 1G – 2G	17	4,00	3042172
▶ PRESS 1G – 2G	19,1	4,50	3042182
▶ PRESS 1G – 2G	21,2	5,00	3042192
▶ PRESS 1G – 2G	23,3	5,50	3042202
▶ PRESS 2G – 3G	25,5	6,00	3042212
▶ PRESS 2G – 3G	27,6	6,50	3042222
▶ PRESS 2G – 3G	29,7	7,00	3042232
▶ PRESS 3G	31,8	7,50	3042242
▶ PRESS 3G	33,9	8,00	3042252
▶ PRESS 3G	36,1	8,50	3042262
▶ PRESS 3G – 4G	40,3	9,50	3042282
▶ PRESS 3G – 4G	42,4	10,00	3042292
▶ PRESS 3G – 4G	46,7	11,00	3042312
▶ PRESS 3G – 4G	50,9	12,00	3042322
▶ PRESS 4G	55,1	13,00	3042332
▶ PRESS 4G	59,4	14,00	3042352
▶ PRESS 4G	63,6	15,00	3042362
▶ PRESS 4G	67,9	16,00	3042382
▶ PRESS 4G	72,1	17,00	3042392
▶ PRESS 4G	76,4	18,00	3042412

Extended head kit

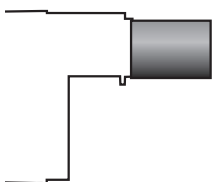

“Standard head” burners can be transformed into “extended head” versions, by using the special kit.

BURNER	STANDARD HEAD LENGTH (mm)	EXTENDED HEAD LENGTH (mm)	KIT CODE
▶ PRESS GW	185	320	3000581
▶ PRESS 2G	245	403	3000538
▶ PRESS 3G	254	412	3000851
▶ PRESS 4G	266	426	3000555

Burner accessories

Spacer kit

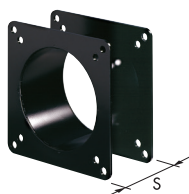

If burner head penetration into the combustion chamber needs reducing, varying thickness spacers are available, as given in the following list.

BURNER	SPACER THICKNESS S (mm)	KIT CODE
► All models	142	3000755

Sound proofing box

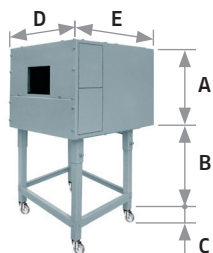

If noise emission needs reducing even further, sound-proofing boxes are available. When a lower "B" dimension is required, it is available the Box Support Kit code 20065135 which allows to reduce it at the fixed dimension of 55 mm. The sound-proofing boxes are not suitable for outdoor use.

BURNER	BOX TYPE	A (mm)	B (mm) min-max	C (mm)	D (mm)	E (mm)	[dB(A)] (*)	BOX CODE
► PRESS GW - 1G PRESS 2G - 3G	C1/3	650	372 - 980	110	690	770	10	3010403
► PRESS 4G	C4/5	850	160 - 980	110	980	930	10	3010404

(*) Average noise reduction according to EN 15036-1 standard

Degasing unit



To solve problem of air in the oil sucked, two versions of degasing unit are available.

BURNER	FILTER	FILTERING DEGREE (µm)	DEGASING UNIT CODE
► PRESS GW PRESS 1G - 2G - 3G(*) - 4G(*)	With filter	50 - 75	3010055

(*) For oil flow larger than 80 kg/h install two degasing units in parallel in the oil supply line.

Two Stage Light Oil Burners

PRESS G SERIES

Burner accessories

PC Interface kit



To connect the control box to a personal computer for the transmission of operation, fault signals and detailed service information, an interface adapter with PC software are available.

BURNER	KIT CODE
► All models	3002719

Protection kit (electromagnetic interferences)

When the burner is installed in a room particularly subject to electromagnetic interference (signals emitted over 10 V/m) due for example to INVERTER presence or in systems where the lengths of the thermostat connections is over 20 meters, this specific protection kit is available as an interface between the thermostatic controls and the burner.

BURNER	KIT CODE
► All models	3010386

PRESS T/G SERIES

The PRESS T/G series of burners covers a firing range from 830 to 5340 kW.

Available in 4 different models, this burners are particularly well suited for matching with pressurized chamber boilers. For their characteristics, they find application in big civil plants for domestic heating or in industrial applications where thermal load is repetitive and predictable.

An hydraulic ram exclusive system, with 3 adjustable positions, regulates dampers opening, allowing air passage in relation to output required: in this way flame stability is optimized in every working point, with micro-regulation available.

The burners are fitted with a microprocessor-based burner safety control box which supplies indication of operation and diagnosis of fault cause.

Guidelines for installation of burners in conformity to EU Regulation:

A RIELLO burner (Heat Generator), where it is matched with a water-based boiler (Heater Housing) with a nominal output ≤ 400 kW, providing heat for heating purposes and heat to deliver sanitary hot water, can be installed:

- With boilers (heater housings) already in service in the field, for replacement of identical products, in conformity to Article 1, paragraph 2, point (G) of the EU Regulation No. 813/2013;
- With boilers (heater housings) on a new installation.

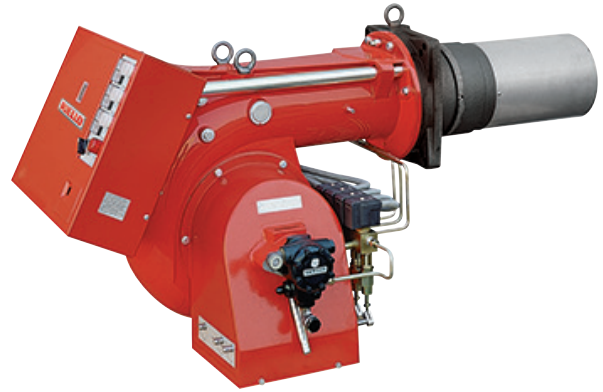

P 140 T/G	380/830 ÷ 1660 kW
P 200 T/G	557/1186 ÷ 2372 kW
P 300 T/G	712/1779 ÷ 3560 kW
P 450 T/G	890/2670 ÷ 5340 kW

FIRING RATES

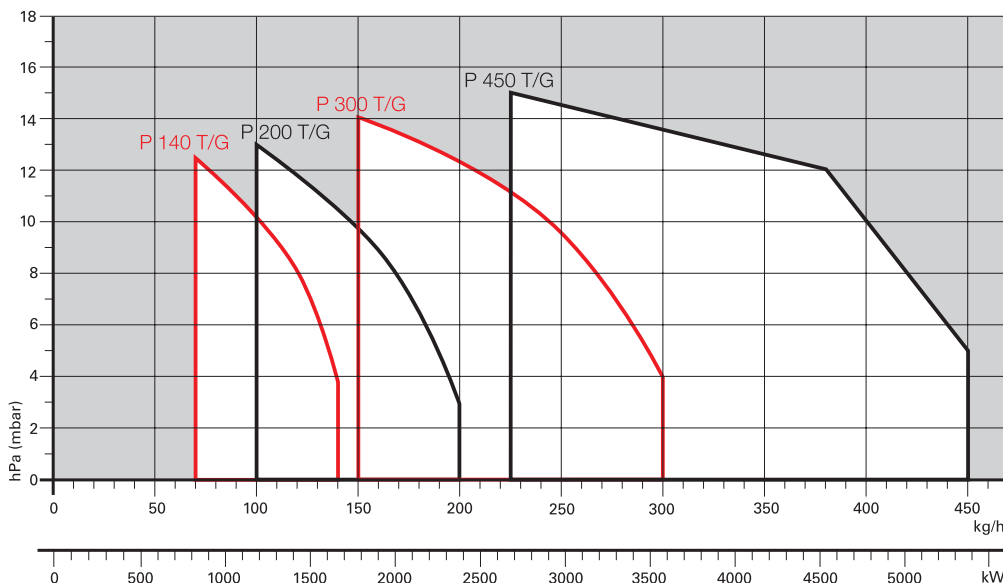

Useful working field for choosing the burner

Test conditions conforming to EN267
 Temperature: 20°C
 Pressure: 1013,5 mbar
 Altitude: 0 m a.s.l.

Three Stage Light Oil Burners

PRESS T/G SERIES

Overall dimensions (mm)

BURNER

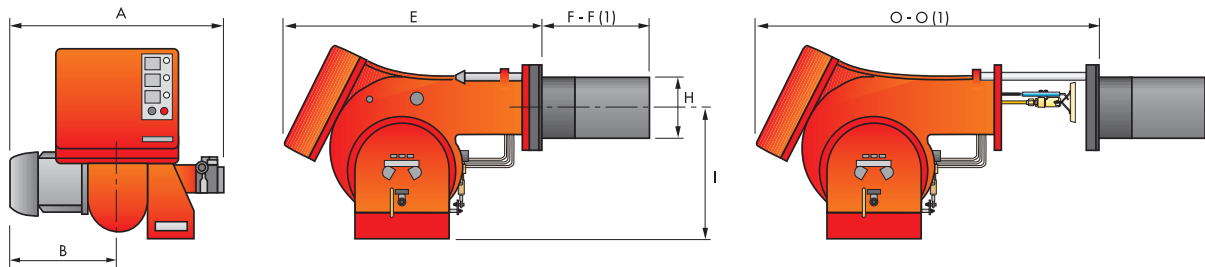

MODEL	A	B	E	F - F (1)	H	I	O - O (1)
▶ P 140 T/G	765	365	890	363 - 473	222	467	1250 - 1360
▶ P 200 T/G	796	396	890	391 - 501	250	467	1280 - 1390
▶ P 300 T/G	858	447	1000	444 - 574	295	496	1440 - 1570
▶ P 450 T/G	950	508	1070	476 - 606	336	525	1546 - 1676

(1) Length with extended combustion head.

BURNER - BOILER MOUNTING FLANGE

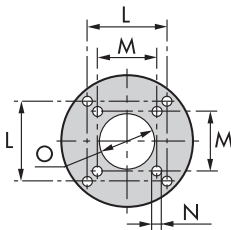

MODEL	L	M	N	O
▶ P 140 T/G	260	230	M14	225
▶ P 200 T/G	260	-	M16	255
▶ P 300 T/G	260	-	M18	300
▶ P 450 T/G	310	-	M20	340

PACKAGING

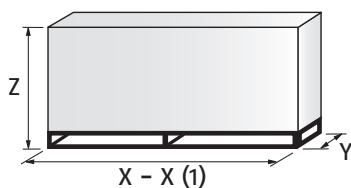

MODEL	X - X (1)	Y	Z	kg
▶ P 140 T/G	1740	990	950	130
▶ P 200 T/G	1740	990	950	220
▶ P 300 T/G	2040	1180	1125	238
▶ P 450 T/G	2040	1180	1125	300

(1) Length with extended combustion head.

Three Stage Light Oil Burners

PRESS T/G SERIES

RIELLO

Specification

DESIGNATION OF SERIES

LIGHT OIL

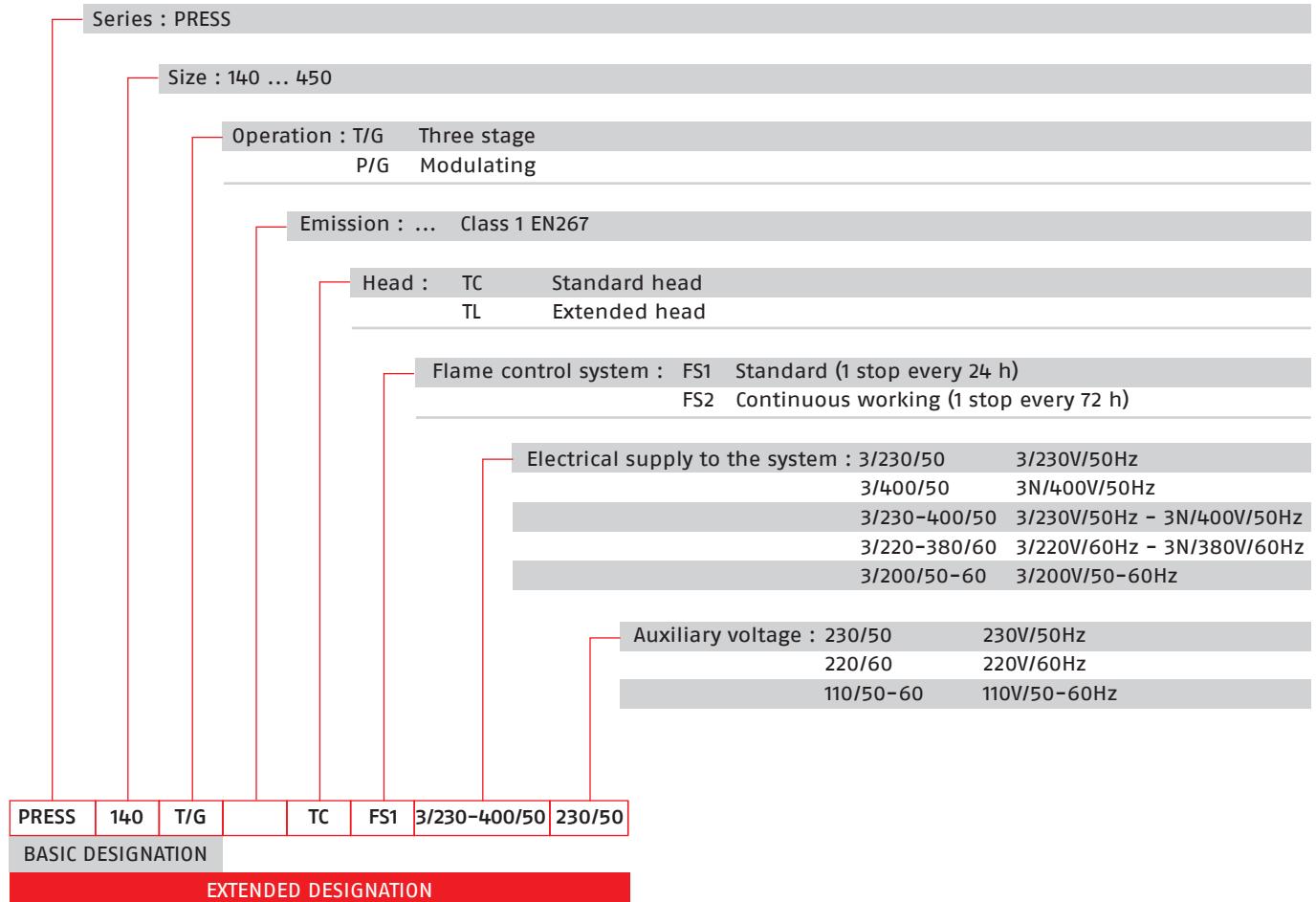

Three Stage Light Oil Burners

PRESS T/G SERIES

Specification

STATE OF SUPPLY

Monoblock forced draught oil burner with three stage operation, fully automatic, made up of:

- Air suction circuit lined with sound-proofing material
- Fan with forward curved blades high performance pressure levels
- Air dampers for air setting controlled by a three stage hydraulic ram
- Starting motor at 2850 rpm, three-phase 400 V with neutral, 50 Hz
- Combustion head, that can be set on the basis of the combustion output, fitted with:
 - stainless steel end cone, resistant to corrosion and high temperatures
 - ignition electrodes
 - flame stability disk
- Gears pump for high pressure fuel supply, fitted with:
 - filter
 - pressure regulator
 - connections for installing a pressure gauge and vacuumeter
 - internal by-pass for single pipe installation
- Valve unit with a oil safety valve and three oil delivery valves on the output circuit;
- Photocell for flame detection
- Microprocessor based burner safety control box, with diagnostic function
- Burner on/off switch
- Flame inspection window
- Slide bars for easier installation and maintenance
- Protection filter against radio interference
- IP X0D (IP 40) electric protection level.

Standard equipment:

- 2 flexible pipes for connection to the oil supply network
- 2 nipples for the connection to the pump
- 4 wiring looms fittings for electrical connections
- 4 screws for fixing the burner flange to the boiler
- 2 slide bar extensions (for the extended model of P 300 T/G and P 450 T/G)
- Gasket for flange
- 1 Star Delta starter (On models where provided)
- Diffuser disk (P 450 T/G)
- Instruction handbook for installation, use and maintenance
- Spare parts catalogue.

Three Stage Light Oil Burners

PRESS T/G SERIES

RIELLO

Available models

CODE	MODEL	HEAT OUTPUT		TOTAL ELECTRICAL POWER	NOTE
		(kW)	(kg/h)		
3476823	PRESS 140 T/G TC FS1 3/230-400/50 230/50	380/830÷1660	32/70÷140	5.2	
3476824	PRESS 140 T/G TL FS1 3/230-400/50 230/50	380/830÷1660	32/70÷140	5.2	
3476885	PRESS 140 T/G TC FS1 3/220-380/60 220/60	380/830÷1660	32/70÷140	5.2	
3476886	PRESS 140 T/G TL FS1 3/220-380/60 220/60	380/830÷1660	32/70÷140	5.2	
3477723	PRESS 200 T/G TC FS1 3/230-400/50 230/50	557/1186÷2372	47/100÷200	5,3	
3477724	PRESS 200 T/G TL FS1 3/230-400/50 230/50	557/1186÷2372	47/100÷200	5,3	
3477785	PRESS 200 T/G TC FS1 3/220-380/60 220/60	557/1186÷2372	47/100÷200	5,3	
3478837	PRESS 300 T/G TC FS1 3/400/50 230/50	712/1779÷3560	60/150÷300	10.9	(2)
3478838	PRESS 300 T/G TL FS1 3/400/50 230/50	712/1779÷3560	60/150÷300	10.9	(2)
3478841	PRESS 300 T/G TC FS1 3/400/50 230/50	712/1779÷3560	60/150÷300	10.6	(1)
3478842	PRESS 300 T/G TL FS1 3/400/50 230/50	712/1779÷3560	60/150÷300	10.6	(1)
3478985	PRESS 300 T/G TC FS1 3/380/60 220/60	712/1779÷3560	60/150÷300	10.7	(2)
3478986	PRESS 300 T/G TL FS1 3/380/60 220/60	712/1779÷3560	60/150÷300	10.7	(2)
3479336	PRESS 450 T/G TC FS1 3/230/50 230/50	890/2670÷5340	75/225÷450	16.9	(1)
3479338	PRESS 450 T/G TC FS1 3/400/50 230/50	890/2670÷5340	75/225÷450	16.9	(1)
3479339	PRESS 450 T/G TL FS1 3/400/50 230/50	890/2670÷5340	75/225÷450	16.9	(1)

(1) Star-delta starting, as standard equipment

(2) For the 3/230/50 or 3/220/60 version, use the 220 - 230V conversion kit

Net calorific value: 11,8 kWh/kg - 10200 kcal/kg - Viscosity at 20°C: 4÷6 mm²/s (cSt)

The burners of PRESS series are in according to 2014/30/EU - 2014/35/EU - 2006/42 EC Directive and EN 267

Three Stage Light Oil Burners

PRESS T/G SERIES

Burner accessories

Nozzles



The following list shows the features and codes on the basis of the maximum required fuel output.

NOTE: each burner needs N° 3 nozzles.

BURNER	GPH	RATED OUTPUT [kg/h]			NOZZLE CODE
		at 10 bar	at 12 bar	at 14 bar	
▶ P 140 T/G	3,50	13,5	14,8	16,1	3042162
▶ P 140 T/G	4,00	15,4	17	18,4	3042172
▶ P 140 T/G	4,50	17,3	19,1	20,7	3042182
▶ P 140 T/G - P 200 T/G	5,00	19,2	21,2	23	3042192
▶ P 140 T/G - P 200 T/G	5,50	21,1	23,3	25,3	3042202
▶ P 140 T/G - P 200 T/G	6,00	23,1	25,5	27,7	3042212
▶ P 140 T/G - P 200 T/G	6,50	25	27,6	30	3042222
▶ P 140 T/G - P 200 T/G	7,00	26,9	29,7	32,3	3042232
▶ P 140 T/G - P 200 T/G	7,50	28,8	31,8	34,6	3042242
▶ P 140 T/G - P 200 T/G	8,00	30,8	33,9	36,9	3042252
▶ P 140 T/G - P 200 T/G	8,50	32,7	36,1	39,2	3042262
▶ P 140 T/G - P 200 T/G	9,50	36,5	40,3	43,8	3042282
▶ P 140 T/G - P 200 T/G	10,00	38,4	42,4	46,1	3042292
▶ P 140 T/G - P 200 T/G	11,00	42,3	46,7	50,7	3042312
▶ P 200 T/G	12,00	46,1	50,9	55,3	3042322
▶ P 200 T/G	13,00	50	55,1	59,9	3042332
▶ P 200 T/G - P 300 T/G	14,00	53,8	59,4	64,5	3042352
▶ P 200 T/G - P 300 T/G	15,00	57,7	63,6	69,2	3042362
▶ P 300 T/G	16,00	61,5	67,9	73,8	3042382
▶ P 300 T/G	17,00	65,4	72,1	78,4	3042392
▶ P 300 T/G - P 450 T/G	18,00	69,2	76,4	83	3042412
▶ P 300 T/G - P 450 T/G	19,00	73	80,6	87,6	3042422
▶ P 300 T/G - P 450 T/G	20,00	76,9	84,8	92,2	3042442
▶ P 300 T/G - P 450 T/G	22,00	84,6	93,3	101,4	3042462
▶ P 300 T/G - P 450 T/G	24,00	92,2	101,8	110,6	3042472
▶ P 450 T/G	26,00	99,9	110,3	119,9	3042482
▶ P 450 T/G	28,00	107,6	118,8	129,1	20018051
▶ P 450 T/G	30,00	110,4	122	132,4	3042502
▶ P 450 T/G	32,00	117,8	130,1	150,1	3042512
▶ P 450 T/G	35,00	128,8	142,1	154,5	3042522

Burner accessories

Spacer kit

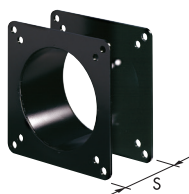

If burner head penetration into the combustion chamber needs reducing, varying thickness spacers are available, as given in the following list.

BURNER	SPACER THICKNESS S (mm)	KIT CODE
▶ P 140 T/G	102	3000722
▶ P 200 T/G	102	3000722
▶ P 300 T/G	122	3000723
▶ P 450 T/G	130	3000751

Sound proofing box

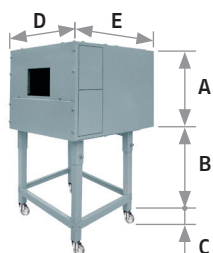

If noise emission needs reducing even further, sound-proofing boxes are available. When a lower "B" dimension is required, it is available the Box Support Kit code 20065135 which allows to reduce it at the fixed dimension of 55 mm. The sound-proofing boxes are not suitable for outdoor use.

BURNER	BOX TYPE	A (mm)	B (mm) min-max	C (mm)	D (mm)	E (mm)	[dB(A)] (*)	BOX CODE
▶ P 140 T/G ▶ P 200 T/G	C4/5	850	160 - 980	110	980	930	10	3010404
▶ P 300 T/G ▶ P 450 T/G	C7	1255	160 - 980	110	1140	1345	10	3010376

(*) Average noise reduction according to EN 15036-1 standard

Burner support

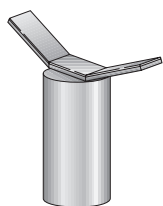

For easier maintenance, a mobile burner support has been designed, which means the burner can be dismantled without the need of forklift trucks.

BURNER	SUPPORT CODE
▶ P 300 T/G - P 450 T/G	3000731

220-230 V conversion kit

This kit is required to convert the 380-400 V models into the 220 or 230 V version.

BURNER	SUPPORT CODE
▶ P 300 T/G	20163347

Three Stage Light Oil Burners

PRESS T/G SERIES

Burner accessories

PC Interface kit



To connect the control box to a personal computer for the transmission of operation, fault signals and detailed service information, an interface adapter with PC software are available.

BURNER	KIT CODE
► P 140 T/G - P 200 T/G - P 300 T/G - P 450 T/G	3002719

Protection kit (electromagnetic interferences)

When the burner is installed in a room particularly subject to electromagnetic interference (signals emitted over 10 V/m) due for example to INVERTER presence or in systems where the lengths of the thermostat connections is over 20 meters, this specific protection kit is available as an interface between the thermostatic controls and the burner.

BURNER	KIT CODE
► All models	3010386

PRESS P/G SERIES

The PRESS P/G series of burners covers a firing range from 415 to 5340 kW.

Setting can be "two stage progressive" or, alternatively, "modulating" with the installation of a PID logic regulator and respective probes, which guarantees a turn down ratio of 3:1.

The versatility of this range makes the burner well suited for use on commercial or industrial applications where the load factor is subject to wide variations over a short period of time.

Simplified maintenance is achieved by Riello designed slide bar system, which allows easy access to all of the essential components of the combustion head.

Guidelines for installation of burners in conformity to EU Regulation:

A RIELLO burner (Heat Generator), where it is matched with a water-based boiler (Heater Housing) with a nominal output ≤ 400 kW, providing heat for heating purposes and heat to deliver sanitary hot water, can be installed:

- With boilers (heater housings) already in service in the field, for replacement of identical products, in conformity to Article 1, paragraph 2, point (G) of the EU Regulation No. 813/2013;
- With boilers (heater housings) on a new installation.

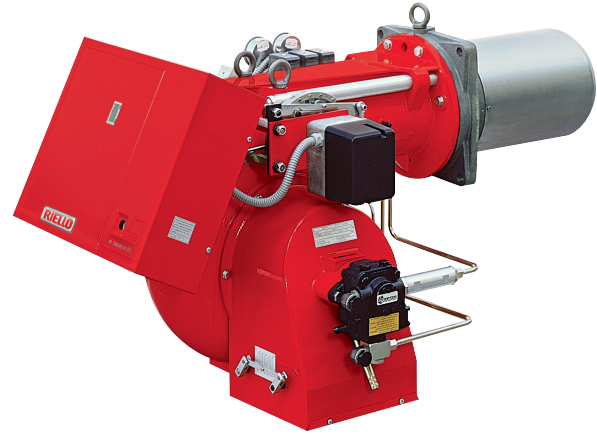

LIGHT OIL

P 140 P/G	415/830 ÷ 1660 kW
P 200 P/G	590/1185 ÷ 2370 kW
P 300 P/G	890/1780 ÷ 3560 kW
P 450 P/G	1190/2670 ÷ 5340 kW

FIRING RATES

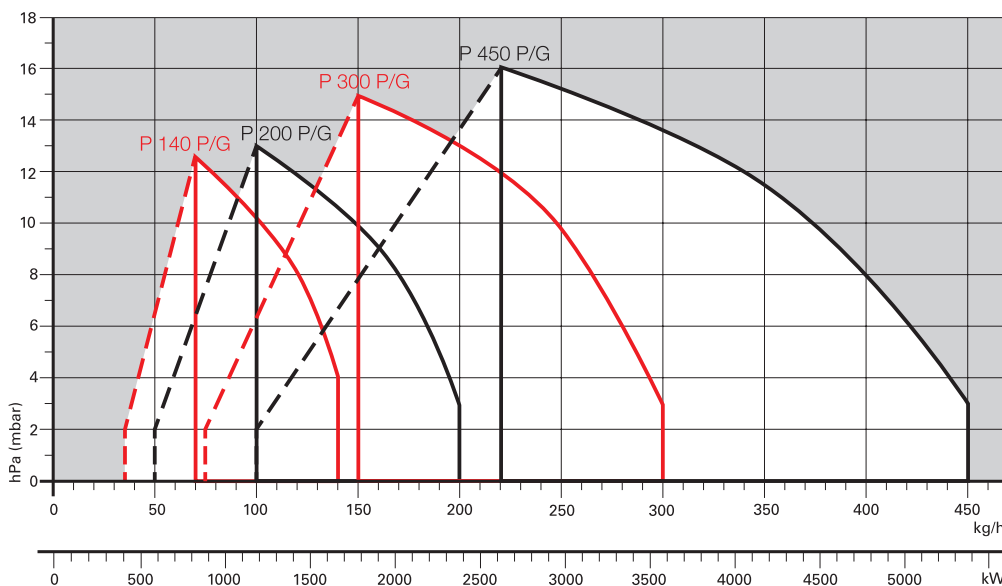

Useful working field for choosing the burner

Modulation range

Test conditions conforming to EN267
 Temperature: 20°C
 Pressure: 1013,5 mbar
 Altitude: 0 m a.s.l.

Modulating Light Oil Burners

PRESS P/G SERIES

Overall dimensions (mm)

BURNER

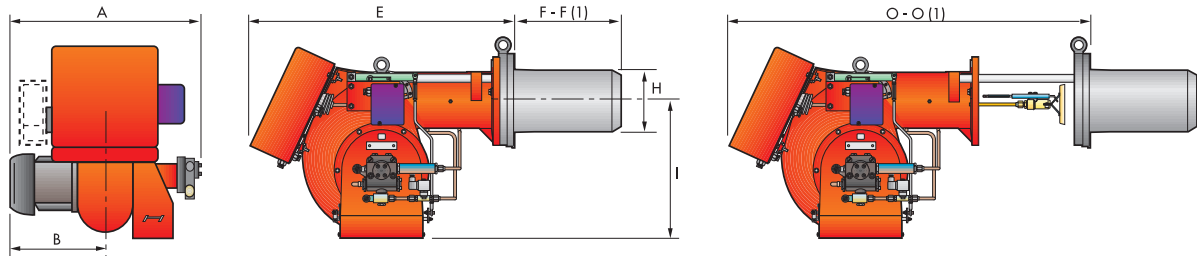

MODEL	A	B	E	F - F (1)	H	I	O - O (1)
▶ P 140 P/G	765	365	890	363 - 473	222	467	1250 - 1360
▶ P 200 P/G	796	396	890	391 - 501	250	467	1280 - 1390
▶ P 300 P/G	858	447	1000	444 - 574	295	496	1440 - 1570
▶ P 450 P/G	950	508	1070	476 - 606	336	525	1546 - 1676

(1) Length with extended combustion head.

BURNER - BOILER MOUNTING FLANGE

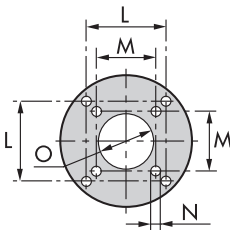

MODEL	L	M	N	O
▶ P 140 P/G	260	230	M14	225
▶ P 200 P/G	260	-	M16	255
▶ P 300 P/G	260	-	M18	300
▶ P 450 P/G	310	-	M20	340

PACKAGING

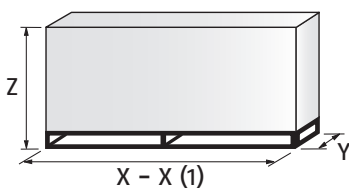

MODEL	X - X (1)	Y	Z	kg
▶ P 140 P/G	1740	990	950	130
▶ P 200 P/G	1740	990	950	220
▶ P 300 P/G	2040	1180	1125	238
▶ P 450 P/G	2040	1180	1125	300

(1) Length with extended combustion head.

PRESS P/G SERIES

Specification

DESIGNATION OF SERIES

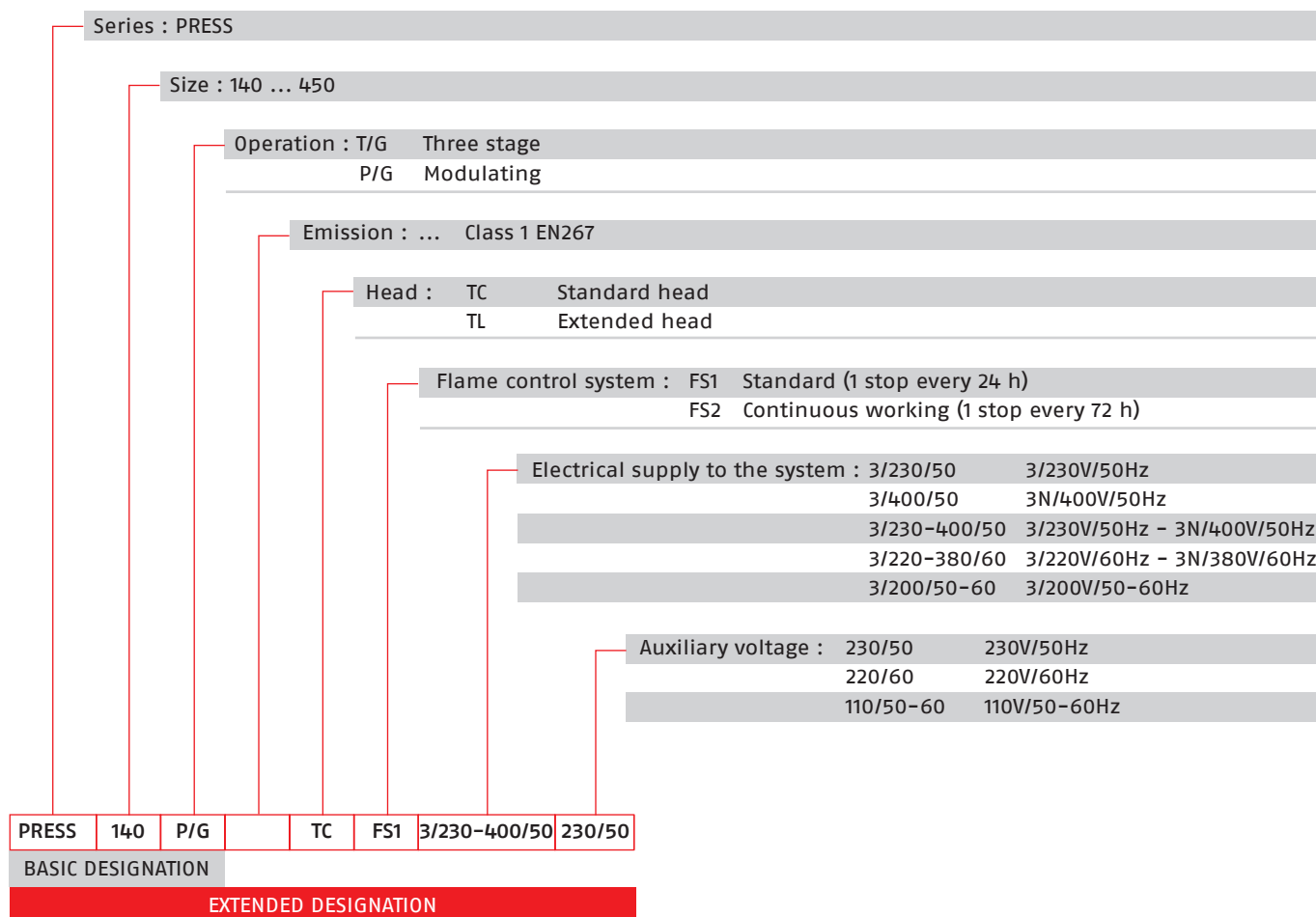

Specification

STATE OF SUPPLY

Monoblock forced draught oil burner, two stage progressive or modulating operation, with a kit, fully automatic, made up of:

- Air suction circuit
- Fan with forward curved blades high performance pressure levels
- Air damper for air setting and automatic oil output regulator controlled by a servomotor with variable cam
- Starting motor at 2850rpm, three-phase 400V with neutral, 50Hz
- Combustion head, that can be set on the basis of the required output, fitted with:
 - stainless steel end cone, resistant to corrosion and high temperatures
 - ignition electrodes
 - flame stability disk
- Gears pump for high pressure fuel supply, fitted with:
 - filter
 - pressure regulator
 - connections for installing a pressure gauge and vacuumeter
 - internal by-pass for single pipe installation
- Valve unit with a double oil safety valve on the output circuit and double safety valve on the return circuit
- Safety oil pressure switch for stop the burner in the case of problems on return circuit
- Photocell for flame detection
- Burner safety control box, fitted with control functions for the correct positioning of the servomotor and possibility of post-ventilation by just changing the electric wiring
- Flame inspection window
- Slide bars for easier installation and maintenance
- Protection filter against radio interference
- IP X0D (IP 40) electric protection level.

Standard equipment:

- 2 flexible pipes for connection to the oil supply network
- 2 nipples for the connection to the pump
- wiring looms fittings for electrical connections
- 4 screws for fixing the burner flange to the boiler
- 2 slide bar extensions (for the extended head models of P 300 P/G e P 450 P/G)
- 1 star delta starter (on models where provided)
- Instruction handbook for installation, use and maintenance
- Spare parts catalogue.

PRESS P/G SERIES

Available models

CODE	MODEL	HEAT OUTPUT		TOTAL ELECTRICAL POWER (kW)	NOTE
		(kW)	(kg/h)		
20169232	PRESS 300 P/G TC FS1 3/400/50 230/50	890/1780÷3560	75/150÷300	10.6	(2)(3)
20169233	PRESS 300 P/G TL FS1 3/400/50 230/50	890/1780÷3560	75/150÷300	10.6	(2)(3)
20169224	PRESS 300 P/G TC FS1 3/400/50 230/50	890/1780÷3560	75/150÷300	10.6	(1)(3)
20169234	PRESS 300 P/G TL FS1 3/400/50 230/50	890/1780÷3560	75/150÷300	10.6	(1)(3)
20169235	PRESS 450 P/G TC FS1 3/400/50 230/50	1190/2670÷5340	100/225÷450	16.9	(1)(3)
20169236	PRESS 450 P/G TL FS1 3/400/50 230/50	1190/2670÷5340	100/225÷450	16.9	(1)(3)

(1) Star-delta starting, as standard equipment

(2) For the 3/230/50 version use the 220 - 230 V conversion kit (see the burner accessories paragraph)

(3) with RFGO control box

Net calorific value: 11,8 kWh/kg - 10200 kcal/kg - Viscosity at 20°C: 4÷6 mm²/s (cSt)

The burners of PRESS series are in according to 2014/30/EU - 2014/35/EU - 2006/42 EC Directive and EN 267.

Due to the improvement applied on the technical specification of some products, some burner codes will change during year 2019. The table below summarizes the correspondence between the previous and the new code.

MODEL	NEW CODE	OLD CODE
PRESS 300 P/G TC FS1 3/400/50 230/50	20169232 (3)	3478941
PRESS 300 P/G TL FS1 3/400/50 230/50	20169233 (3)	3478942
PRESS 300 P/G TC FS1 3/400/50 230/50	20169224 (3)	3478945
PRESS 300 P/G TL FS1 3/400/50 230/50	20169234 (3)	3478946
PRESS 450 P/G TC FS1 3/400/50 230/50	20169235 (3)	3479371
PRESS 450 P/G TL FS1 3/400/50 230/50	20169236 (3)	3479372

Modulating Light Oil Burners

PRESS P/G SERIES

Burner accessories

Return nozzles

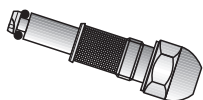

The following list shows the features and codes on the basis of the maximum required fuel output.

NOTE: each burner needs N° 1 nozzle.

BURNER	RATED OUTPUT kg/h (*)	NOZZLES BERGONZO B5 45° WITHOUT "SA" NEEDLE CODE	NOZZLES FLUIDICS N2 45° WITHOUT NEEDLE CODE
▶ P 140 P/G	70	3009303	3045471
▶ P 140 P/G	80	3009305	3045472
▶ P 140 P/G	90	3009307	3045473
▶ P 140 - 200 P/G	100	3009310	3045475
▶ P 140 - 200 P/G	125	3009312	3045477
▶ P 200 - 300 P/G	150	3009314	3045479
▶ P 200 - 300 P/G	175	3009316	3045481
▶ P 200 - 300 P/G	200	3009318	3045483
▶ P 300 - 400 P/G	225	3009320	3045485
▶ P 300 - 400 P/G	250	3009322	3045487
▶ P 300 - 400 P/G	275	3009324	3045489
▶ P 300 - 400 P/G	300	3009326	3045491
▶ P 450 P/G	325	3009328	3045493
▶ P 450 P/G	350	3009330	3045495
▶ P 450 P/G	375	3009332	3045497
▶ P 450 P/G	400	3009334	3045499
▶ P 450 P/G	425	3009336	3045500
▶ P 450 P/G	450	3009338	3045501

(*) Nozzle rated delivery is referred to atomised pressure

Spacer kit

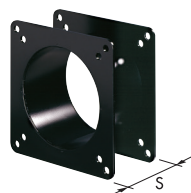

If burner head penetration into the combustion chamber needs reducing, varying thickness spacers are available, as given in the following list.

BURNER	SPACER THICKNESS S (mm)	CODE
▶ P 140 P/G	102	3000722
▶ P 200 P/G	102	3000722
▶ P 300 P/G	122	3000723
▶ P 450 P/G	130	3000751

Burner accessories

Sound proofing box

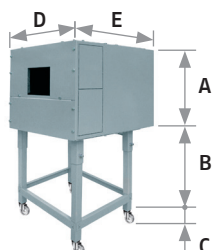

If noise emission needs reducing even further, sound-proofing boxes are available. When a lower "B" dimension is required, it is available the Box Support Kit code 20065135 which allows to reduce it at the fixed dimension of 55 mm. The sound-proofing boxes are not suitable for outdoor use.

BURNER	BOX TYPE	A (mm)	B (mm) min-max	C (mm)	D (mm)	E (mm)	[dB(A)] (*)	BOX CODE
▶ P 140 P/G P 200 P/G	C4/5	850	160 - 980	110	980	930	10	3010404
▶ P 300 P/G P 450 P/G	C7	1255	160 - 980	110	1140	1345	10	3010376

(*) Average noise reduction according to EN 15036-1 standard

Accessories for modulating operation



To obtain modulating operation, the PRESS P/G series of burners requires a regulator. For remote setpoint use RWF 55.

BURNER	TYPE	CODE
▶ P 140 - 200 - 300 - 450 P/G	RWF 50.2	20100018
	RWF 55.5	20101965



The relative temperature or pressure probes fitted to the regulator, must be chosen on the basis of the application.

BURNER	PROBE TYPE	RANGE (°C) (bar)	PROBE CODE
▶ P 140 - 200 - 300 - 450 P/G	Temperature PT 100	-100 ÷ 500°C	3010110
▶ P 140 - 200 - 300 - 450 P/G	Pressure 4 ÷ 20 mA	0 ÷ 2,5 bar	3010213
▶ P 140 - 200 - 300 - 450 P/G	Pressure 4 ÷ 20 mA	0 ÷ 16 bar	3010214
▶ P 140 - 200 - 300 - 450 P/G	Pressure 4 ÷ 20 mA	0 ÷ 25 bar	3090873



Depending on the servomotor fitted to the burner, a three-pole potentiometer (1000 Ω) can be installed to check the position of the servomotor.

BURNER	POTENTIOMETER KIT CODE
▶ P 140 - 200 - 300 - 450 P/G	3010021

Modulating Light Oil Burners

PRESS P/G SERIES

Burner accessories

Burner support

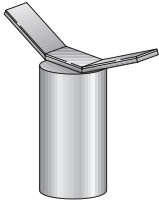

For easier maintenance, a mobile burner support has been designed, which means the burner can be dismantled without the need of forklift trucks.

BURNER	SUPPORT CODE
► P 300 P/G – P 450 P/G	3000731

220-230 V conversion kit

This kit is required to convert the 380–400 V models into the 220 or 230 V version.

BURNER	SUPPORT CODE
► P 300 P/G	20163347

RIELLO 40 N SERIES

The Riello 40 N series of one stage heavy oil burners, is a complete range of products developed to respond to any request for the use of heavy oil in heating systems and light industrial processes. The Riello 40 N series is available in two different models, with an output ranging from 34 to 217 kW, divided into two basic structures.

All the models use many components designed by Riello for the Riello 40 series but are fitted with special components for heavy oil combustion.

The high quality level guarantees safe working.

In developing these burners, special attention has been paid to reducing noise, to the ease of installation and adjustment, to reducing the size in order to facilitate installation in any kind of boiler on the market.

All the models are conform to EMC European Directives, for Low Voltage and Machinery.

All the Riello 40 N burners are tested before leaving the factory.



N 10	51 ÷ 114 kW
N 20	114 ÷ 228 kW

Guidelines for installation of burners in conformity to EU Regulation:

A RIELLO burner (Heat Generator), where it is matched with a water-based boiler (Heater Housing) with a nominal output ≤ 400 kW, providing heat for heating purposes and heat to deliver sanitary hot water, can be installed:

- With boilers (heater housings) already in service in the field, for replacement of identical products, in conformity to Article 1, paragraph 2, point (G) of the EU Regulation No. 813/2013;
- With boilers (heater housings) on a new installation.

FIRING RATES

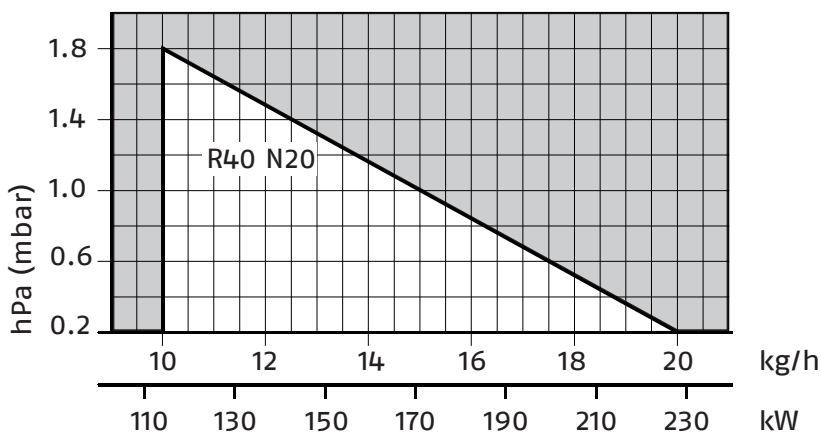
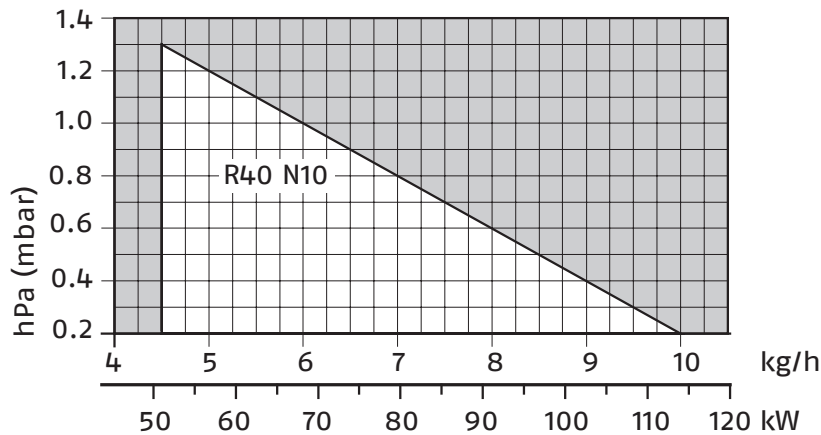

Useful working field for choosing the burner

Test conditions
Temperature: 20°C
Pressure: 1013,5 mbar
Altitude: 0 m a.s.l.

One Stage Heavy Oil Burners

RIELLO 40 N SERIES

Overall dimensions (mm)

BURNER

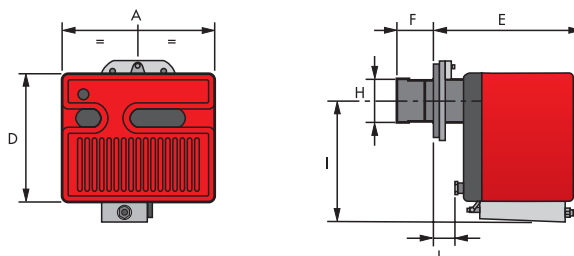

MODEL	A	D	E	F	H	I	L
► N10	305	262	275	108	105	262	25
► N20	350	298	295	118	125	280	35

BURNER - BOILER MOUNTING FLANGE

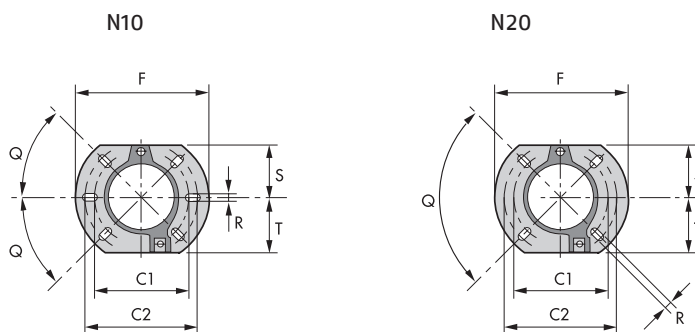

MODEL	C1	C2	F	Q	R	S	T
► N10	140	170	189	45°	11	83	83
► N20	160	190	213	90°	11	99	99

PACKAGING

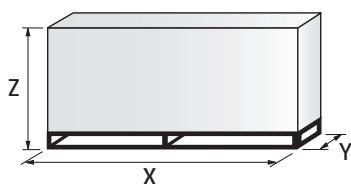

MODEL	X	Y	Z	kg
► N10	395	307	375	26
► N20	425	352	410	29

RIELLO 40 N SERIES

Specification

DESIGNATION OF SERIES

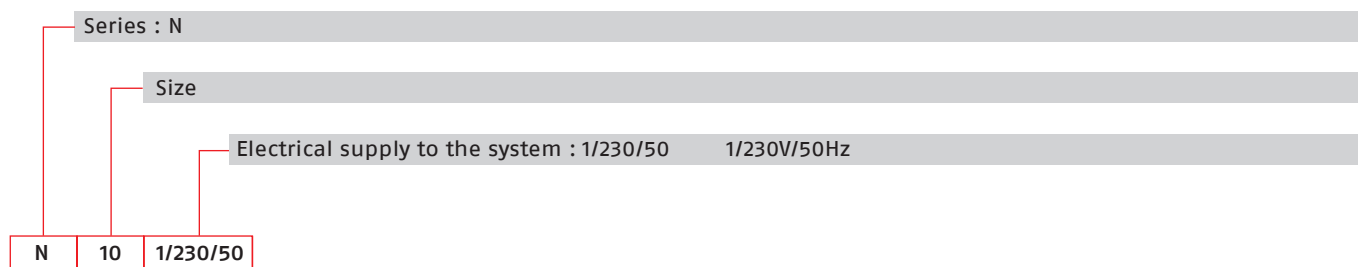

STATE OF SUPPLY

Completely automatic monobloc heavy oil burners, one stage operation, made up to:

- Fan with forward curve blades
- Metallic cover lined with sound-proofing material
- Metallic air damper
- Single phase electric motor 230 V, 50 Hz
- Combustion head fitted with:
 - stainless steel head cone, resistant to high temperatures
 - ignition electrodes
 - flame stability disk
- Geared pump for fuel supply, fitted with:
 - filter
 - pressure regulator
 - attachments for fitting a pressure gauge and vacuum meter
 - internal by-pass for preparing for single-pipe installations
- Heavy oil preheater
- Heavy oil filter into the preheater
- Heavy oil manometer
- Heavy oil thermometer
- Heavy oil protection valve
- Heavy oil outlet valve
- Adjustment thermostat with probe
- Thermostat for fuel low temperature
- Fuel feed solenoid valve incorporated in the pump
- Terminal block for electrical links
- Photocell for flame detection
- Electronic flame control equipment
- Electronic transformer
- Protective filter against radio interference
- IP X0D (IP 40) protection level.

Standard equipment:

- Heavy oil nozzle
- Two flexible pipes with seal for connection to the heavy oil supply line
- Two nipples for connection to the pump
- Flange, screws and nuts for fixing
- Thermal gasket
- Hinge kit
- Grommet
- Instruction handbook for installation, use and maintenance
- Spare parts catalogue.

One Stage Heavy Oil Burners

RIELLO 40 N SERIES

Available models

CODE	MODEL	HEAT OUTPUT		TOTAL ELECTRICAL POWER	NOTE
		(kW)	(kg/h)	(kW)	
20096830	N10 1/230/50	51 - 114	4,5 - 10	1,1	(1)
20096845	N20 1/230/50	114 - 228	10 - 20	1,8	(1)

Net calorific value: 11,3 kWh/kg; 9720 kcal/kg - Max Viscosity at 50°C: 5°E (38 mm²/s, cSt), Type MEDIUM HEAVY OIL / USA n° 4.
 (1) Austrian version.

Burner accessories

Cartridge filter



BURNER	KIT CODE
► N10 - N20	3004588

Self-cleaning filter



BURNER	KIT CODE
► N10 - N20	3000861

RN SERIES

The RN series of burners covers a firing range from 228 to 1481 kW, and has been designed for use in hot or superheater water boilers, hot air or steam generators, diathermic oil boilers.

Operation is "two stage"; the burners are fitted with an electronic device LED PANEL, which supplies information about burner working.

All necessary components of hydraulic heavy-oil circuit are assembled in a separate structure, called BAG, for easy and fast installation.

Optimisation of sound emissions is guaranteed by the use of fans with forward curved blades and sound deadening material incorporated in the air suction circuit.

The elevated performance of the fans and combustion head, guarantee flexibility of use and excellent working at all firing rates.

The exclusive design ensures reduced dimensions, simple use and maintenance. A wide range of accessories guarantees elevated working flexibility.

RN 28	114/228 ÷ 342 kW
RN 38	136/273 ÷ 456 kW
RN 50	171/342 ÷ 570 kW
RN 70	228/456 ÷ 798 kW
RN 100	342/684 ÷ 1140 kW
RN 130	456/912 ÷ 1481 kW

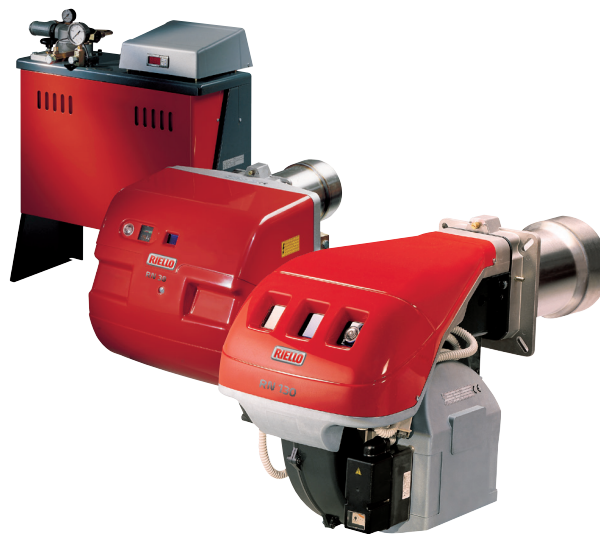

HEAVY OIL

Guidelines for installation of burners in conformity to EU Regulation:

A RIELLO burner (Heat Generator), where it is matched with a water-based boiler (Heater Housing) with a nominal output ≤ 400 kW, providing heat for heating purposes and heat to deliver sanitary hot water, can be installed:

- With boilers (heater housings) already in service in the field, for replacement of identical products, in conformity to Article 1, paragraph 2, point (G) of the EU Regulation No. 813/2013;
- With boilers (heater housings) on a new installation.

FIRING RATES

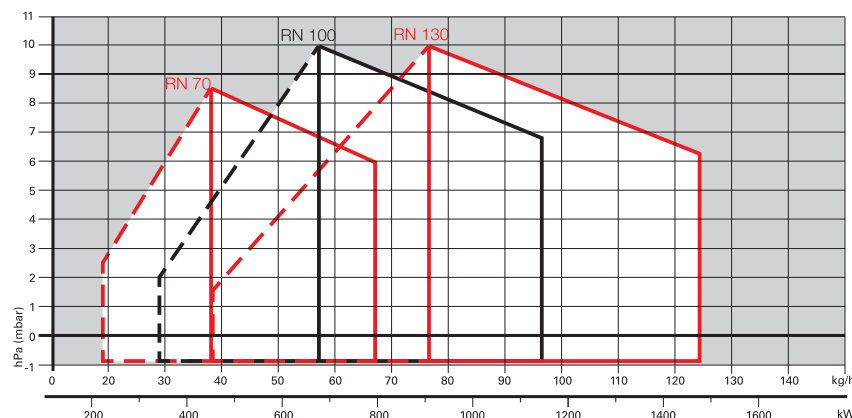
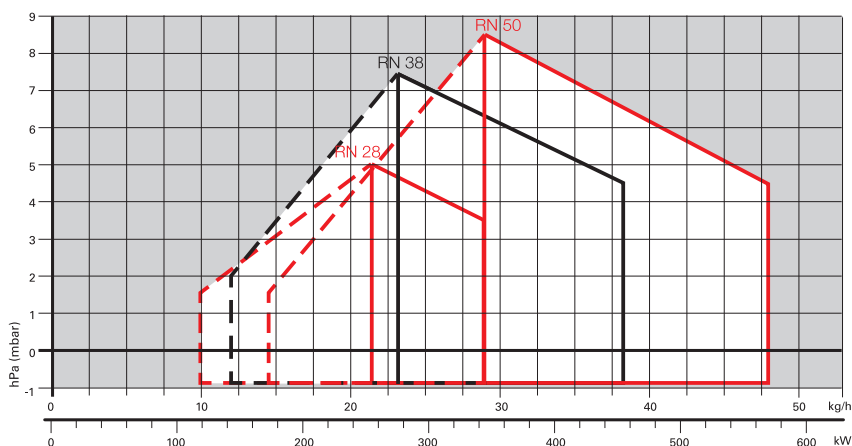

Useful working field for choosing the burner



1st stage operation range

Test conditions conforming to EN267
 Temperature: 20°C
 Pressure: 1013,5 mbar
 Altitude: 0 m a.s.l.

Two Stage Heavy Oil Burners

RN SERIES

Overall dimensions (mm)

BURNER

RN 28 - 38 - 50

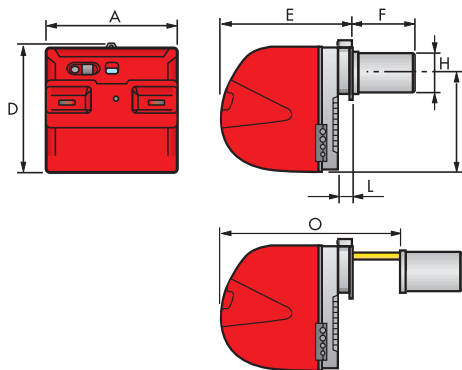

RN 70 - 100 - 130

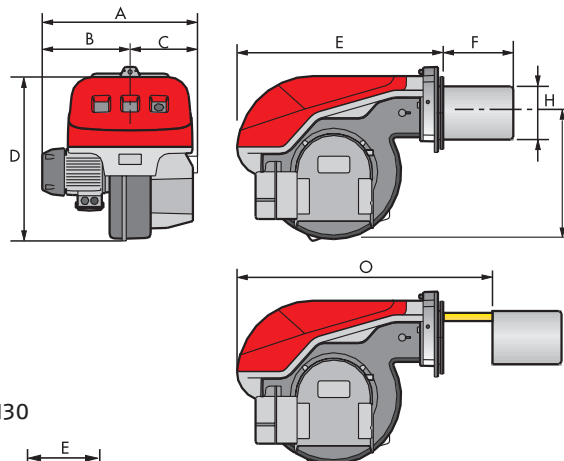

BAG 40 - 50 - 130

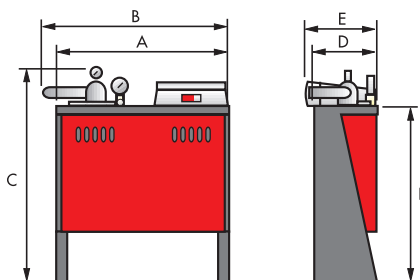

MODEL	A	B	C	D	E	F	H	I	L	O
▶ RN 28	476	-	-	474	468	265	166	352	52	730
▶ RN 38	476	-	-	474	468	265	166	352	52	730
▶ RN 50	476	-	-	474	468	265	166	352	52	730
▶ RN 70	511	296	215	555	680	310	189	430	-	951
▶ RN 100	527	312	215	555	680	330	200	430	-	951
▶ RN 130	553	338	215	555	680	330	220	430	-	951
▶ BAG 40 - 50 - 130	680	763	780	276	324	650	-	-	-	-

BURNER - BOILER MOUNTING FLANGE

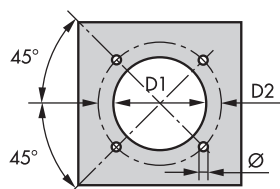

MODEL	D1	D2	Ø
▶ RN 28 - 38 - 50	170	224	M8
▶ RN 70	200	275-325	M12
▶ RN 100	210	275-325	M12
▶ RN 130	230	275-325	M12

PACKAGING

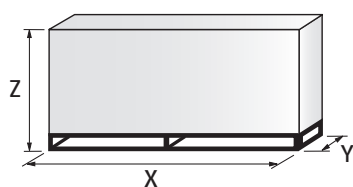

MODEL	X	Y	Z	kg
▶ RN 28	1015	630	500	52
▶ RN 38 - 50	1015	630	500	57
▶ RN 70	1054	614	666	59
▶ RN 100	1054	614	666	62
▶ RN 130	1054	614	666	65
▶ BAG 40	824	859	394	62
▶ BAG 50	824	859	394	67
▶ BAG 130	824	859	394	69

Specification

DESIGNATION OF SERIES

Series : R	
Fuel : S Natural gas L Light oil LS Light oil / Natural gas N Heavy oil	
Size	
Operation : /1 One stage ... Two stage /M Modulating /E Electronic cam /P Proportioning air/gas valve /EV Electronic cam predisposed for variable speed (with inverter)	
Emission : ... Class 1 EN267 MZ Class 2 EN267 BLU Class 3 EN267 MX Class 2 EN267	
Head : TC Standard head TL Extended head	
Diagnostic : LP Led panel ST Status panel	
Flame control system : FS1 Standard (1 stop every 24 h) FS2 Continuous working (1 stop every 72 h)	
Electrical supply to the system :	
1/230/50	1/230V/50Hz
3/230/50	3/230V/50Hz
3/400/50	3N/400V/50Hz
3/230-400/50	3/230V/50Hz - 3N/400V/50Hz
3/220/60	3/220V/60Hz
3/380/60	3N/380V/60Hz
3/220-380/60	3/220V/60Hz - 3N/380V/60Hz
Auxiliary voltage : 230/50-60 230V/50-60Hz 110/50-60 110V/50-60Hz	
ID : Differential switch	

R	N	50			TC	LP	FS1	3/230-400/50	230/50-60	
---	---	----	--	--	----	----	-----	--------------	-----------	--

BASIC DESIGNATION

EXTENDED DESIGNATION

Two Stage Heavy Oil Burners

RN SERIES

Specification

STATE OF SUPPLY

Monobloc forced draught heavy oil burner, two stage operation, made up of:

- Air suction circuit lined with sound-proofing material
- Fan with reverse curve blades
- Air damper for air setting controlled by a servomotor
- Combustion head, that can be set on the basis of required output
- Photocell for flame detection
- Burner safety control box
- Electronic device to check all burners operational modes (Led Panel)
- Burner on/off switch
- Manual 1st and 2nd stage switch
- Plugs for electrical connections (RN 28-38-50)
- Flame inspection window
- Slide bars for easier installation and maintenance
- Protection filter against radio interference
- IP 44 electric protection level.

BAG

- Pressure gauge for fuel supply loop
- Atomising pressure gauge
- Self-controlling resistances for warming suction filter, delivery filter, valve and pump
- High and Low point thermostat
- High point thermostat with reset push-button
- Loop pressure control switch with burner operation enable (set at 1 bar)
- Pump
- Pump motor
- Pre-purge valve
- Degasing unit
- Valve for gas release from degasing unit
- Comb-filter at delivery
- Terminal strip
- Wiring looms
- Bag/Burner electrical connection socket
- Electronic thermostat
- Heating element Pt100
- Back pressure valve
- Comb-filter at pump suction
- Pre-heater.

Standard equipment:

- 2 flexible hoses for burner/bag connection (L = 1.3 m)
- 1 insulation for flexible hoses
- 2 nipples for flexible hoses
- 1 insulating screen
- 4 screws for fixing the burner flange to the boiler
- Wiring looms for electrical connections (for RN 28-38-50 model)
- 1 tube for installing BAG on left (for RN 28-38-50 model)
- 2 nozzles
- Instruction handbook for installation, use and maintenance
- Spare parts catalogue.

Two Stage Heavy Oil Burners

RN SERIES

RIELLO

Available models

CODE	MODEL						HEAT OUTPUT		TOTAL ELECTRICAL POWER (kW)	NOTE
							(kW)	(kg/h)		
3433201	RN 28	TC	LP	FS1	3/230-400/50	230/50-60	114/228-342	10/20-30	4	
3433301	RN 38	TC	LP	FS1	3/230-400/50	230/50-60	136/273-456	12/24-40	5	
3433401	RN 50	TC	LP	FS1	3/230-400/50	230/50-60	171/342-570	15/30-50	6	
3434101	RN 70	TC	LP	FS1	3/230-400/50	230/50-60	228/456-798	20/40-70	10	
3434201	RN 100	TC	LP	FS1	3/230-400/50	230/50-60	342/684-1140	30/60-100	10	
3434301	RN 130	TC	LP	FS1	3/230-400/50	230/50-60	456/912-1481	40/80-130	11	
3891510	BAG 40								3	(1)
3891511	BAG 50								4	(2)
3891512	BAG 130								8	(3)

(1) For RN 28 burner.

(2) For RN 38-50 burners.

(3) For RN 70-100-130 burners.

Net calorific value: 11,16 kWh/kg; 9.600 kcal/kg - Max Viscosity at 50°C: 20°E (150 mm²/s, cSt), Type BUNKER B / USA no. 5.

The burners of RN series are in according to 2014/30/EU - 2014/35/EU - 2006/42 EC Directive and EN 267.

Two Stage Heavy Oil Burners

RN SERIES

Burner accessories

Nozzle



TYPE F80 PL 45°

The nozzles must be ordered separately. The following table shows the features and codes on the basis of the maximum required output.

NOTE: each burner needs N° 2 nozzles.

BURNER	RATED DELIVERY (kg/h) at 22,5 bar	GPH	NOZZLE CODE
▶ RN 28	11,3	2	3043121
▶ RN 28 - RN 38	12,7	2,25	3043131
▶ RN 28 - RN 38	14,1	2,5	3043141
▶ RN 38 - RN 50	16,9	3	3043151
▶ RN 50 - RN 70	19,7	3,5	3043161
▶ RN 50 - RN 70	22,5	4	3043171
▶ RN 70	25,3	4,5	3043181
▶ RN 70 - RN 100	28,1	5	3043191
▶ RN 70 - RN 100	33,4	6	3043211
▶ RN 100 - RN 130	39,4	7	3043231
▶ RN 100 - RN 130	47,8	8,5	3043261
▶ RN 130	53,4	9,5	3043271
▶ RN 130	59	10,5	3043301

TYPE F80 PL 60°

BURNER	RATED DELIVERY (kg/h) at 22,5 bar	GPH	NOZZLE CODE
▶ RN 28	9,8	1,75	3041112
▶ RN 28	11,3	2	3043122
▶ RN 28 - RN 38	12,7	2,25	3043132
▶ RN 28 - RN 38	14,1	2,5	3043142
▶ RN 38 - RN 50	16,9	3	3043152
▶ RN 50 - RN 70	19,7	3,5	3043162
▶ RN 50 - RN 70	22,5	4	3043172
▶ RN 70	25,3	4,5	3043182
▶ RN 70 - RN 100	28,1	5	3043192
▶ RN 70 - RN 100	33,4	6	3043212
▶ RN 100 - RN 130	39,4	7	3043232
▶ RN 100 - RN 130	47,8	8,5	3043262
▶ RN 130	53,4	9,5	3043272
▶ RN 130	59	10,5	3043302

Connection flange kit

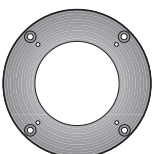

A kit is available for use where the burner opening on the boiler is of excessive diameter.

BURNER	KIT CODE
▶ RN 28 - RN 38 - RN 50	3010138

PRESS N SERIES

The PRESS N series of burners covers a firing range from 171 to 1140 kW and they have been designed for use in civil installations of average dimensions, like building areas and large apartment groups or for use in industrial applications, like small or medium plants.

Operation is two stage; a servomotor adjust automatically air damper opening, to obtain the right air delivery on both stage. The burners are fitted with a microprocessor control panel which supplies indication of operation and diagnosis of fault cause.

The combustion head, that can be set on the basis of required output, allows optimal performance ensuring good combustion and reducing fuel consumption and is available in two different length to be selected on the basis of specific application requirements.

In basic version the burners are supplied for use with heavy oil 7°E viscosity, but they can be supplied with higher viscosity oil with a specific heaters kit.

Simplified maintenance is achieved by the slide bar system, which allows easy access to all of the essential components of the combustion head.

Guidelines for installation of burners in conformity to EU Regulation:

A RIELLO burner (Heat Generator), where it is matched with a water-based boiler (Heater Housing) with a nominal output ≤ 400 kW, providing heat for heating purposes and heat to deliver sanitary hot water, can be installed:

- With boilers (heater housings) already in service in the field, for replacement of identical products, in conformity to Article 1, paragraph 2, point (G) of the EU Regulation No. 813/2013;
- With boilers (heater housings) on a new installation.

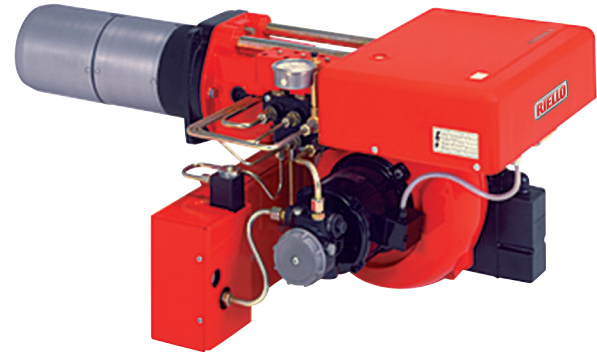

PRESS 30 N	85/171 ÷ 342 kW
PRESS 45 N	114/205 ÷ 513 kW
PRESS 60 N	171/342 ÷ 684 kW
PRESS 100 N	285/490 ÷ 1140 kW

FIRING RATES

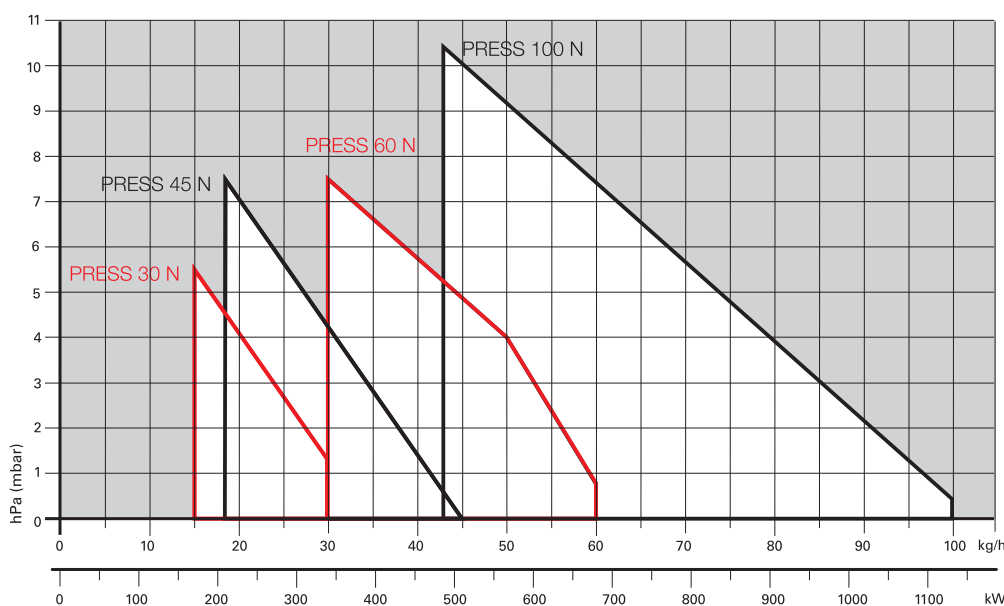

Useful working field for choosing the burner

Test conditions conforming to EN267
 Temperature: 20°C
 Pressure: 1013,5 mbar
 Altitude: 0 m a.s.l.

Two Stage Heavy Oil Burners

PRESS N SERIES

Overall dimensions (mm)

BURNER

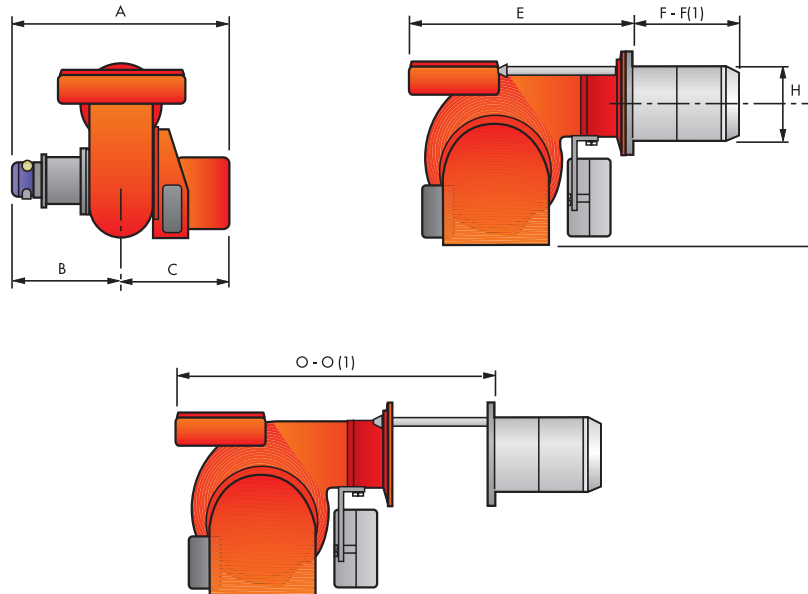

MODEL	A	B	C	E	F - F(1)	H	I	O - O(1)
► PRESS 30 N	625	335	290	625	185 - 320	161	305	905 - 1080
► PRESS 45 N	625	335	290	625	235 - 370	161	305	925 - 1100
► PRESS 60 N	625	335	290	660	245 - 400	172	335	940 - 1115
► PRESS 100 N	625	335	290	710	250 - 410	195	370	1010 - 1195

(1) Length with extended combustion head

BURNER - BOILER MOUNTING FLANGE

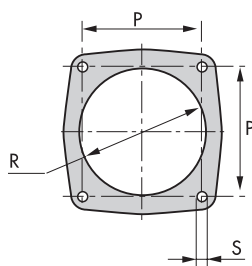

MODEL	P	R	S
► PRESS 30 N	160	170	M 10
► PRESS 45 N	160	170	M 10
► PRESS 60 N	160	180	M 10
► PRESS 100 N	195	205	M 12

PACKAGING

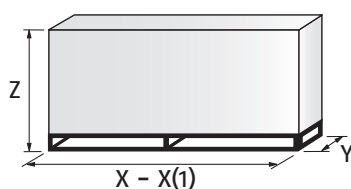

MODEL	X - X(1)	Y	Z	kg
► PRESS 30 N	1000 - 1015	790	550	84
► PRESS 45 N	1000 - 1200	790	550	84
► PRESS 60 N	925 - 1200	790	650	87
► PRESS 100 N	1000 - 1200	790	650	104

(1) Length with extended combustion head

Two Stage Heavy Oil Burners

PRESS N SERIES

RIELLO

Specification

DESIGNATION OF SERIES

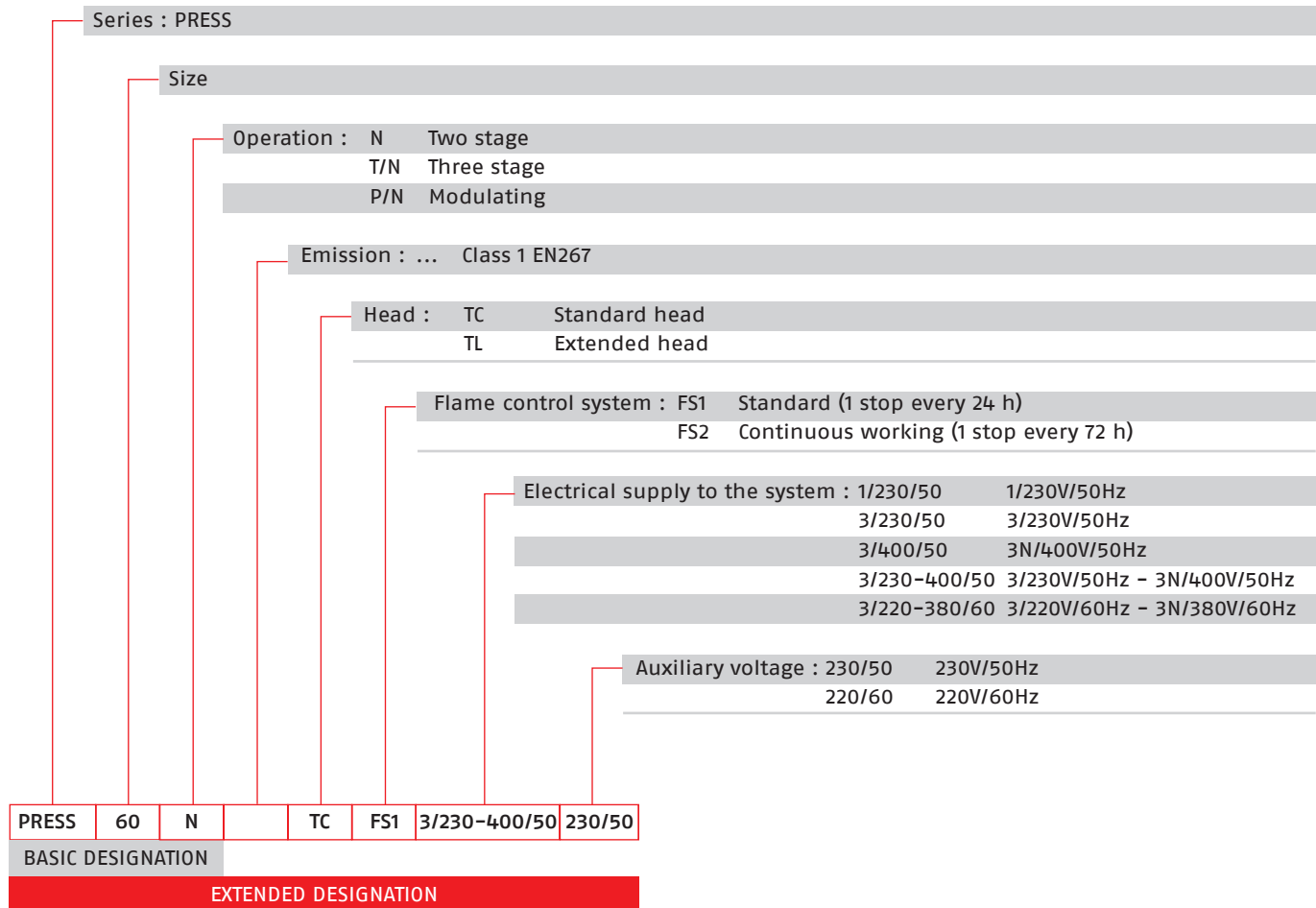

HEAVY OIL

Two Stage Heavy Oil Burners

PRESS N SERIES

Specification

STATE OF SUPPLY

Monoblock forced draught heavy oil burner, two stage operation, made up of:

- Air suction circuit
- Fan with forward curved blades
- Air dampers for air setting controlled by a servomotor
- Starting motor at 2850 rpm
- Combustion head, fitted with:
 - stainless steel end cone, resistant to corrosion and high temperatures
 - ignition electrodes
 - flame stability disk
- Gears pump for high pressure fuel supply, fitted with:
 - filter
 - pressure regulator
 - connections for installing a pressure gauge and vacuumeter
 - internal by-pass for single pipe installation
- Valve unit with a double oil safety valve on the output circuit;
- Oil preheater provided with chance of a thermometer application for temperature control;
- Servomotor for air damper regulation;
- Photocell for flame detection;
- Microprocessor-based burner safety control box, with diagnostic function
- Flame inspection window
- Slide bars for easier installation and maintenance
- Protection filter against radio interference
- IP X0D (IP 40) protection level.

Standard equipment:

- 2 flexible hoses for pipe connection
- 2 gaskets for flexible hoses
- 2 nipples for flexible hoses
- 1 thermal insulation screen
- 4 screws for fixing the burner flange to the boiler
- 2 nozzles (see table of available burner model)
- 2 extensions for bars (for long head version)
- Instruction handbook for installation, use and maintenance
- Spare parts catalogue.

Two Stage Heavy Oil Burners

PRESS N SERIES

RIELLO

Available models

CODE	MODEL				HEAT OUTPUT		TOTAL ELECTRICAL POWER (kW)	NOTE
					(kW)	(kg/h)		
20132092	PRESS 30 N	TC	FS1	1/230/50 230/50	85/171-342	7,5/15-30	3,4	(1)
20132093	PRESS 30 N	TL	FS1	1/230/50 230/50	85/171-342	7,5/15-30	3,4	(1)
20132103	PRESS 45 N	TC	FS1	3/230-400/50 230/50	114/205-513	10/18-45	3,6	(1)
20132104	PRESS 45 N	TL	FS1	3/230-400/50 230/50	114/205-513	10/18-45	3,6	(1)
3434923	PRESS 60 N	TC	FS1	3/230-400/50 230/50	171/342-684	15/30-60	5,5	(1)
3434924	PRESS 60 N	TL	FS1	3/230-400/50 230/50	171/342-684	15/30-60	5,5	(1)
3435923	PRESS 100 N	TC	FS1	3/230-400/50 230/50	285/490-1140	25/43-100	9,0	(1)
3435924	PRESS 100 N	TL	FS1	3/230-400/50 230/50	285/490-1140	25/43-100	9,0	(1)

(1) 2 nozzles as standard equipment.

Net calorific value: 11,16 kWh/kg; 9600 kcal/kg - Max Viscosity at 50°C: 7°E (50 mm²/s, cSt), Type MEDIUM HEAVY OIL / USA n° 4.

For viscosity higher 7°E up to 60°C (450 mm²/s, cSt), heavy oil, heating cartridges or nozzle, pump and valves group plus pipe heating cables, factory installed are available. Please ask for specific codes.

The burners of PRESS series are in according to 2014/30/EU - 2014/35/EU - 2006/42 EC Directive and EN 267.

Two Stage Heavy Oil Burners

PRESS N SERIES

Burner accessories

Extended head kit

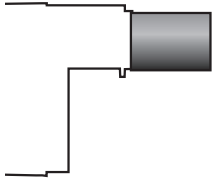

“Standard head” burners can be transformed into “extended head” versions, by using the special kit. The KITS available for the various burners, giving the original and the extended lengths, are listed below.

BURNER	STANDARD HEAD LENGTH (mm)	EXTENDED HEAD LENGTH (mm)	KIT CODE
► PRESS 30 N	185	320	20015280
► PRESS 60 N	245	400	3092198

Spacer kit



If burner head penetration into the combustion chamber needs reducing, varying thickness spacers are available, as given in the list.

BURNER	SPACER THICKNESS S (mm)	KIT CODE
► PRESS 30 N - 45 N - 60 N	142	3000755
► PRESS 100 N	142	3000802

Sound proofing box

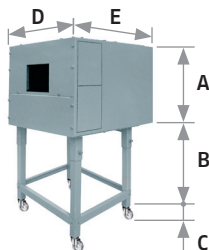

If noise emission needs reducing even further, sound-proofing boxes are available. When a lower “B” dimension is required, it is available the Box Support Kit code 20065135 which allows to reduce it at the fixed dimension of 55 mm. The sound-proofing boxes are not suitable for outdoor use.

BURNER	BOX TYPE	A (mm)	B (mm) min-max	C (mm)	D (mm)	E (mm)	[dB(A)] (*)	BOX CODE
► PRESS 30 N - 45 N PRESS 60 N - 100 N	C4/5	650	372 - 980	110	980	930	10	3010404

(*) Average noise reduction according to EN 15036-1 standard

Self-cleaning filter



For cleaning heavy oil from dirty particles and impurities, it is equipped with a thermostatic heater for oil with 50°E viscosity at 50°C.

FILTER TYPE	FILTER CODE
► $\phi=1$ 50°E - 50°C	3000790

HEATER TYPE	HEATER CODE
► Thermostatic heater 80W	3010059

Burner accessories

Heavy oil kit



Equipped with electrical heaters, it permits the employment of PRESS N burners with fuel oil of max. viscosity 20°E at 50°C (type BUNKER B / USA n° 5).

BURNER	MAX VISCOSITY	KIT CODE
▶ PRESS 30 N - 45 N	20°E at 50°C	20134878
▶ PRESS 60 N - 100 N	20°E at 50°C	3010013

Cartridge filter



For cleaning heavy oil from dirty particles and impurities, it is equipped with a cartridge system equipped with electronic resistance for oil with 7°E viscosity at 50°C.

FILTER TYPE	FILTER CODE
▶ Cartridge filter 7°E - 50°C	3005209

PC Interface kit



To connect the control box to a personal computer for the transmission of operation, fault signals and detailed service information, an interface adapter with PC software are available.

BURNER	KIT CODE
▶ PRESS 30 N - 45 N - 60 N - 100 N	3002719

Protection kit (electromagnetic interferences)

When the burner is installed in a room particularly subject to electromagnetic interference (signals emitted over 10 V/m) due for example to INVERTER presence or in systems where the lengths of the thermostat connections is over 20 meters, this specific protection kit is available as an interface between the thermostatic controls and the burner.

BURNER	KIT CODE
▶ All models	3010386

Two Stage Heavy Oil Burners

PRESS N SERIES

Burner accessories

Nozzle



TYPE F80 PL 45°

The nozzles must be ordered separately. The following table shows the features and codes on the basis of the maximum required output.

NOTE: each burner needs N° 2 nozzles.

BURNER	RATED DELIVERY (kg/h) at 20 bar	GPH	NOZZLE CODE
▶ PRESS 30 N - 45 N	10,6	2	3043121
▶ PRESS 30 N - 45 N	11,9	2,25	3043131
▶ PRESS 30 N - 45 N - 60 N	13,2	2,5	3043141
▶ PRESS 45 N - 60 N	15,8	3	3043151
▶ PRESS 45 N - 60 N - 100 N	18,5	3,5	3043161
▶ PRESS 45 N - 60 N - 100 N	21,1	4	3043171
▶ PRESS 60 N - 100 N	23,7	4,5	3043181
▶ PRESS 60 N - 100 N	26,4	5	3043191
▶ PRESS 100 N	29	5,5	3043201
▶ PRESS 100 N	31,7	6	3043211
▶ PRESS 100 N	34,3	6,5	3043221
▶ PRESS 100 N	36,9	7	3043231
▶ PRESS 100 N	39,6	7,5	3043241
▶ PRESS 100 N	44,8	8,5	3043261

TYPE F80 PL 60°

BURNER	RATED DELIVERY (kg/h) at 20 bar	GPH	NOZZLE CODE
▶ PRESS 30 N	6,6	1,25	3041092
▶ PRESS 30 N - 45 N	7,9	1,5	3041102
▶ PRESS 30 N - 45 N	9,2	1,75	3041112
▶ PRESS 30 N - 45 N	10,6	2	3043122
▶ PRESS 30 N - 45 N	11,9	2,25	3043132
▶ PRESS 30 N - 45 N - 60 N	13,2	2,5	3043142
▶ PRESS 45 N - 60 N	15,8	3	3043152
▶ PRESS 45 N - 60 N - 100 N	18,5	3,5	3043162
▶ PRESS 45 N - 60 N - 100 N	21,1	4	3043172
▶ PRESS 60 N - 100 N	23,7	4,5	3043182
▶ PRESS 60 N - 100 N	26,4	5	3043192
▶ PRESS 100 N	29	5,5	3043202
▶ PRESS 100 N	31,7	6	3043212
▶ PRESS 100 N	34,3	6,5	3043222
▶ PRESS 100 N	36,9	7	3043232
▶ PRESS 100 N	39,6	7,5	3043242
▶ PRESS 100 N	44,8	8,5	3043262

PRESS N/ECO SERIES

PRESS N/ECO burner series covers a firing range from 171 to 1140 kW and it has been designed for operation with low sulphur fuels. The burners are equipped with a separate low speed pump.

They have been designed for use in civil installations of average dimensions, like building areas and large apartment groups or for use in industrial applications, like small or medium plants.

Operation is two stage; a servomotor adjust automatically air damper opening, to obtain the right air delivery on both stage. The burners are fitted with a microprocessor control panel which supplies indication of operation and diagnosis of fault cause.

The combustion head, that can be set on the basis of required output, allows optimal performance ensuring good combustion and reducing fuel consumption and is available in two different length to be selected on the basis of specific application requirements.

As standard the burners are supplied with electrical heaters installed on crucial parts of hydraulics circuit, for use with heavy oil viscosity up to 20°C.

Simplified maintenance is achieved by the slide bar system, which allows easy access to all of the essential components of the combustion head.

Guidelines for installation of burners in conformity to EU Regulation:

A RIELLO burner (Heat Generator), where it is matched with a water-based boiler (Heater Housing) with a nominal output ≤ 400 kW, providing heat for heating purposes and heat to deliver sanitary hot water, can be installed:

- With boilers (heater housings) already in service in the field, for replacement of identical products, in conformity to Article 1, paragraph 2, point (G) of the EU Regulation No. 813/2013;
- With boilers (heater housings) on a new installation.

FIRING RATES

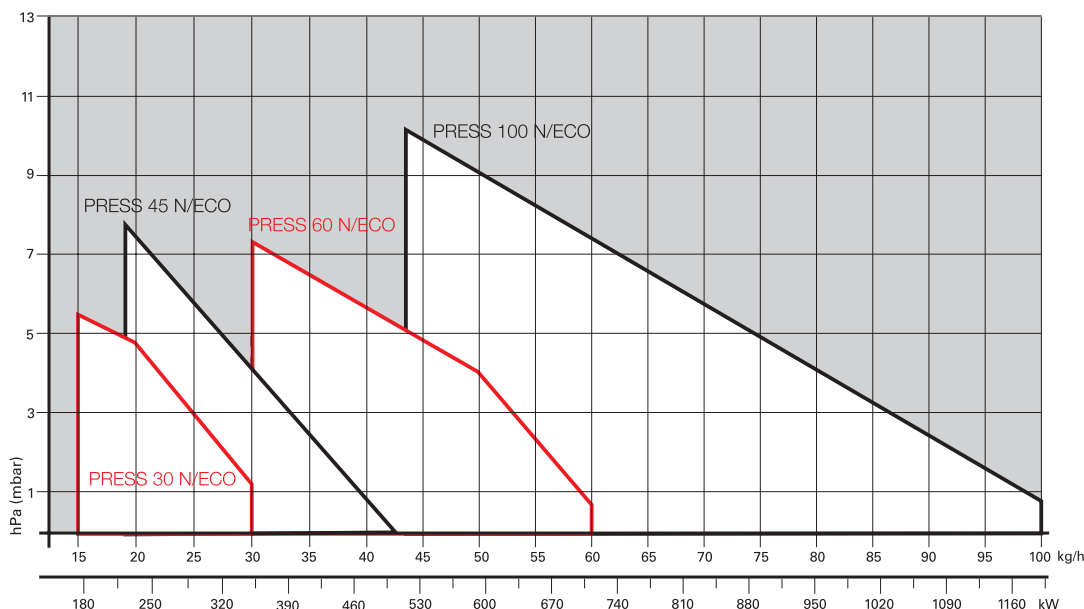

Useful working field for choosing the burner

Test conditions conforming to EN267
 Temperature: 20°C
 Pressure: 1013,5 mbar
 Altitude: 0 m a.s.l.

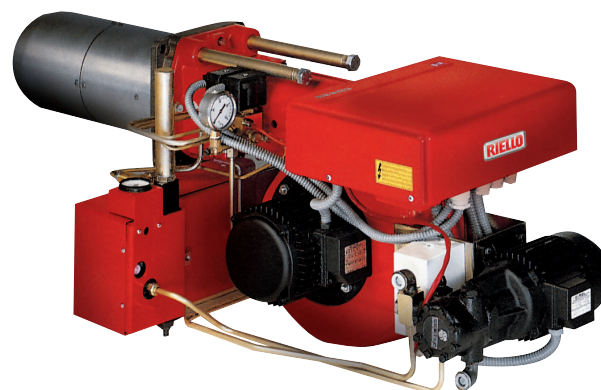

PRESS 30	N/ECO	85/171 ÷ 342	kW
PRESS 45	N/ECO	114/205 ÷ 513	kW
PRESS 60	N/ECO	171/342 ÷ 684	kW
PRESS 100	N/ECO	285/490 ÷ 1140	kW

Two Stage Heavy Oil Burners

PRESS N/ECO SERIES

Overall dimensions (mm)

BURNER

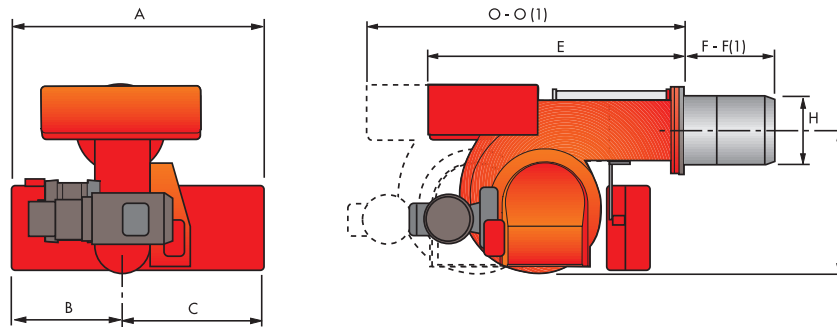

MODEL	A	B	C	E	F - F(1)	H	I	O - O(1)
▶ PRESS 30 N/ECO	625	335	290	625	185 - 320	161	305	968 - 1103
▶ PRESS 45 N/ECO	625	335	290	625	235 - 370	161	305	1018 - 1153
▶ PRESS 60 N/ECO	625	335	290	660	245 - 400	172	335	1079 - 1234
▶ PRESS 100 N/ECO	625	335	290	710	250 - 410	195	370	1126 - 1216

(1) Length with extended combustion head

BURNER - BOILER MOUNTING FLANGE

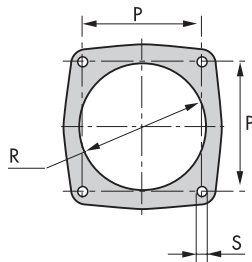

MODEL	P	R	S
▶ PRESS 30 N/ECO	160	170	M 10
▶ PRESS 45 N/ECO	160	170	M 10
▶ PRESS 60 N/ECO	160	180	M 10
▶ PRESS 100 N/ECO	195	205	M 12

PACKAGING

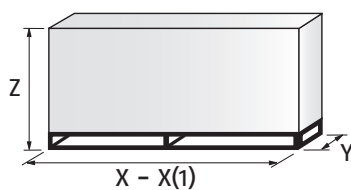

MODEL	X - X(1)	Y	Z	kg
▶ PRESS 30 N/ECO	880 - 1015	690	622	84
▶ PRESS 45 N/ECO	880 - 1015	690	622	84
▶ PRESS 60 N/ECO	925 - 1095	760	652	87
▶ PRESS 100 N/ECO	985 - 1145	790	652	104

(1) Length with extended combustion head

Two Stage Heavy Oil Burners

PRESS N/ECO SERIES

RIELLO

Specification

DESIGNATION OF SERIES

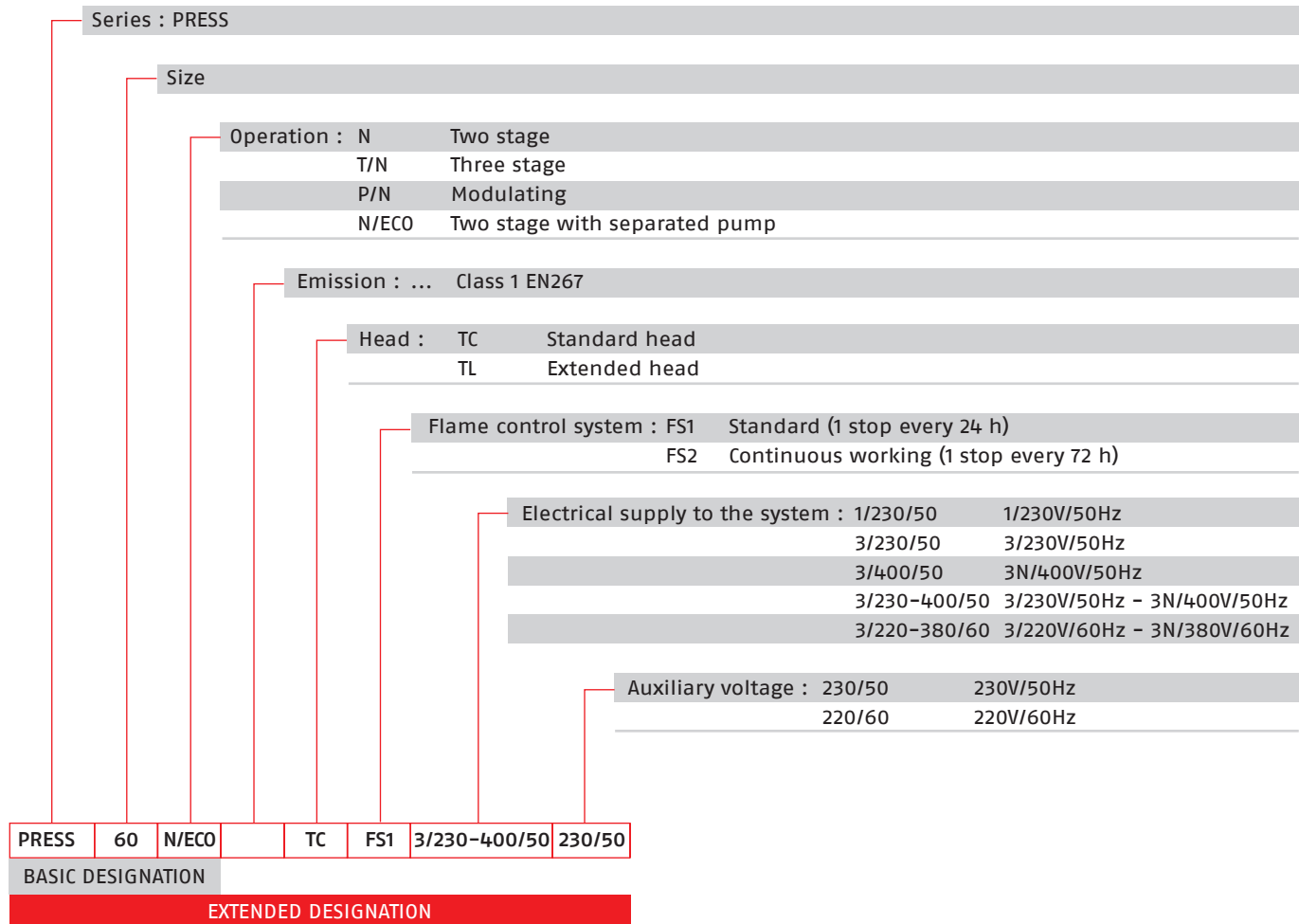

HEAVY OIL

Two Stage Heavy Oil Burners

PRESS N/ECO SERIES

Specification

STATE OF SUPPLY

Monoblock forced draught heavy oil burner, two stage operation, made up of:

- Air suction circuit
- Fan with forward curved blades
- Air dampers for air setting controlled by a servomotor
- Fan motor at 2850 rpm
- Oil pump motor at 1400 rpm
- Combustion head, fitted with:
 - stainless steel end cone, resistant to corrosion and high temperatures
 - ignition electrodes
 - flame stability disk
- Gears pump for high pressure fuel supply, fitted with:
 - filter
 - pressure regulator
 - connections for installing a pressure gauge and vacuumeter
 - internal by-pass for single pipe installation
- Valve unit with a double oil safety valve on the output circuit
- Double filter between pump and nozzle
- Oil preheater provided with chance of a thermometer application for temperature control
- Installed electrical heaters on pump, nozzle holder, valves assembly
- Servomotor for air damper regulation
- Air pressure switch
- Photocell for flame detection
- Microprocessor-based burner safety control box, with diagnostic function
- Flame inspection window
- Slide bars for easier installation and maintenance
- Protection filter against radio interference
- IP X0D (IP 40) protection level.

Standard equipment:

- 2 flexible hoses for pipe connection
- 2 gaskets for flexible hoses
- 2 nipples for flexible hoses
- 1 thermal insulation screen
- 4 screws for fixing the burner flange to the boiler
- 2 nozzles (see table of available burner model)
- 2 extensions for bars (for long head version)
- Instruction handbook for installation, use and maintenance
- Spare parts catalogue.

Two Stage Heavy Oil Burners

PRESS N/ECO SERIES

RIELLO

Available models

CODE	MODEL					HEAT OUTPUT		TOTAL ELECTRICAL POWER (kW)	NOTE
						(kW)	(kg/h)		
3433823	PRESS 30 N/ECO	TC	FS1	3/230-400/50	230/50	85/171-342	7,5/15-30	3,9	(1) (2)
3433824	PRESS 30 N/ECO	TL	FS1	3/230-400/50	230/50	85/171-342	7,5/15-30	3,9	(1) (2)
3434623	PRESS 45 N/ECO	TC	FS1	3/230-400/50	230/50	114/205-513	10/18-45	4,1	(1) (2)
3434624	PRESS 45 N/ECO	TL	FS1	3/230-400/50	230/50	114/205-513	10/18-45	4,1	(1) (2)
3435023	PRESS 60 N/ECO	TC	FS1	3/230-400/50	230/50	171/342-684	15/30-60	6,0	(1) (2)
3435024	PRESS 60 N/ECO	TL	FS1	3/230-400/50	230/50	171/342-684	15/30-60	6,0	(1) (2)
3436023	PRESS 100 N/ECO	TC	FS1	3/230-400/50	230/50	285/490-1140	25/43-100	9,5	(1) (2)
3436024	PRESS 100 N/ECO	TL	FS1	3/230-400/50	230/50	285/490-1140	25/43-100	9,5	(1) (2)

(1) 2 nozzles as standard equipment.

(2) Installed electrical heaters on pump, nozzle holder, valves assembly

Net calorific value: 11,16 kWh/kg; 9600 kcal/kg - Max Viscosity at 50°C: 15°E (115 mm²/s, cSt), Type BUNKER B / USA no. 5.

The burners of PRESS series are in according to 2014/30/EU - 2014/35/EU - 2006/42 EC Directive and EN 267.

Two Stage Heavy Oil Burners

PRESS N/ECO SERIES

Burner accessories

Extended head kit

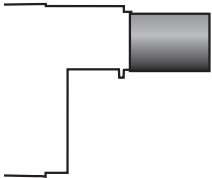

“Standard head” burners can be transformed into “extended head” versions, by using the special kit. The KITS available for the various burners, giving the original and the extended lengths, are listed below.

BURNER	STANDARD HEAD LENGTH (mm)	EXTENDED HEAD LENGTH (mm)	KIT CODE
► PRESS 30 N/ECO	185	320	20015280
► PRESS 60 N/ECO	245	400	3092198

Spacer kit

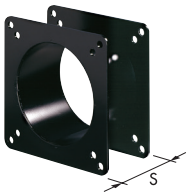

If burner head penetration into the combustion chamber needs reducing, varying thickness spacers are available, as given in the list.

BURNER	SPACER THICKNESS S (mm)	KIT CODE
► P 30 N/ECO – 45 N/ECO – 60 N/ECO	142	3000755
► P 100 N/ECO	142	3000802

Sound proofing box

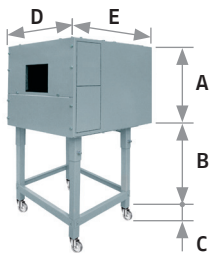

If noise emission needs reducing even further, sound-proofing boxes are available. When a lower “B” dimension is required, it is available the Box Support Kit code 20065135 which allows to reduce it at the fixed dimension of 55 mm. The sound-proofing boxes are not suitable for outdoor use.

BURNER	BOX TYPE	A (mm)	B (mm) min-max	C (mm)	D (mm)	E (mm)	[dB(A)] (*)	BOX CODE
► PRESS 30 – 45 N/ECO PRESS 60 – 100 N/ECO	C4/5	850	160 – 980	110	980	930	10	3010404

(*) Average noise reduction according to EN 15036-1 standard

Self-cleaning filter



For cleaning heavy oil from dirty particles and impurities, it is equipped with a thermostatic heater for oil with 50°E viscosity at 50°C.

FILTER TYPE	FILTER CODE
► $\phi=1$ 50°E – 50°C	3000790

HEATER TYPE	HEATER CODE
► Thermostatic heater 80W	3010059

Burner accessories

Cartridge filter



For cleaning heavy oil from dirty particles and impurities, it is equipped with a cartridge system equipped with electronic resistance for oil with 7°E viscosity at 50°C.

FILTER TYPE	FILTER CODE
► Cartridge filter 7°E – 50°C	3005209

PC Interface kit



To connect the control box to a personal computer for the transmission of operation, fault signals and detailed service information, an interface adapter with PC software are available.

BURNER	KIT CODE
► P 30 N/ECO – 45 N/ECO – 60 N/ECO – 100 N/ECO	3002719

Protection kit (electromagnetic interferences)

When the burner is installed in a room particularly subject to electromagnetic interference (signals emitted over 10 V/m) due for example to INVERTER presence or in systems where the lengths of the thermostat connections is over 20 meters, this specific protection kit is available as an interface between the thermostatic controls and the burner.

BURNER	KIT CODE
► All models	3010386

Two Stage Heavy Oil Burners

PRESS N/ECO SERIES

Burner accessories

Nozzle



TYPE F80 PL 45°

The nozzles must be ordered separately. The following table shows the features and codes on the basis of the maximum required output.

NOTE: each burner needs N° 2 nozzles.

BURNER	RATED DELIVERY (kg/h) at 20 bar	GPH	NOZZLE CODE
▶ P 30 N/ECO - 45 N/ECO	10,6	2	3043121
▶ P 30 N/ECO - 45 N/ECO	11,9	2,25	3043131
▶ P 30 N/ECO - 45 N/ECO - 60 N/ECO	13,2	2,5	3043141
▶ P 45 N/ECO - 60 N/ECO	15,8	3	3043151
▶ P 45 N/ECO - 60 N/ECO - 100 N/ECO	18,5	3,5	3043161
▶ P 45 N/ECO - 60 N/ECO - 100 N/ECO	21,1	4	3043171
▶ P 60 N/ECO - 100 N/ECO	23,7	4,5	3043181
▶ P 60 N/ECO - 100 N/ECO	26,4	5	3043191
▶ P 100 N/ECO	29	5,5	3043201
▶ P 100 N/ECO	31,7	6	3043211
▶ P 100 N/ECO	34,3	6,5	3043221
▶ P 100 N/ECO	36,9	7	3043231
▶ P 100 N/ECO	39,6	7,5	3043241
▶ P 100 N/ECO	44,8	8,5	3043261

TYPE F80 PL 60°

BURNER	RATED DELIVERY (kg/h) at 20 bar	GPH	NOZZLE CODE
▶ P 30 N/ECO	6,6	1,25	3041092
▶ P 30 N/ECO - 45 N/ECO	7,9	1,5	3041102
▶ P 30 N/ECO - 45 N/ECO	9,2	1,75	3041112
▶ P 30 N/ECO - 45 N/ECO	10,6	2	3043122
▶ P 30 N/ECO - 45 N/ECO	11,9	2,25	3043132
▶ P 30 N/ECO - 45 N/ECO - 60 N/ECO	13,2	2,5	3043142
▶ P 45 N/ECO - 60 N/ECO	15,8	3	3043152
▶ P 45 N/ECO - 60 N/ECO - 100 N/ECO	18,5	3,5	3043162
▶ P 45 N/ECO - 60 N/ECO - 100 N/ECO	21,1	4	3043172
▶ P 60 N/ECO - 100 N/ECO	23,7	4,5	3043182
▶ P 60 N/ECO - 100 N/ECO	26,4	5	3043192
▶ P 100 N/ECO	29	5,5	3043202
▶ P 100 N/ECO	31,7	6	3043212
▶ P 100 N/ECO	34,3	6,5	3043222
▶ P 100 N/ECO	36,9	7	3043232
▶ P 100 N/ECO	39,6	7,5	3043242
▶ P 100 N/ECO	44,8	8,5	3043262

PRESS T/N - T/N ECO SERIES

The PRESS T/N series of burners covers a firing range from 800 to 5130 kW. They have been designed in three versions for use in commercial and industrial installations, to burn different oil viscosity from 7 up to 60 °E @ 50°C. Operation is three-stage, thus making these burners suitable for installations that have variable but predictable heating requirements.

A servomotor adjusts automatically air damper to the opening value, determined to obtain always the necessary fuel consumption. Every model of PRESS T/N series is available in two different combustion head length (short or long head) to be selected on the basis of specific application requirements. An electric preheater has been fitted to maintain the oil at the correct atomising temperature at maximum output and special heaters kits are separately supplied for burning high viscosity oil.

Simplified maintenance is achieved by the Riello designed slide bar system, which allows easy access to all of the essential components of the combustion head.

Guidelines for installation of burners in conformity to EU Regulation:

A RIELLO burner (Heat Generator), where it is matched with a water-based boiler (Heater Housing) with a nominal output ≤ 400 kW, providing heat for heating purposes and heat to deliver sanitary hot water, can be installed:

- With boilers (heater housings) already in service in the field, for replacement of identical products, in conformity to Article 1, paragraph 2, point (G) of the EU Regulation No. 813/2013;
- With boilers (heater housings) on a new installation.

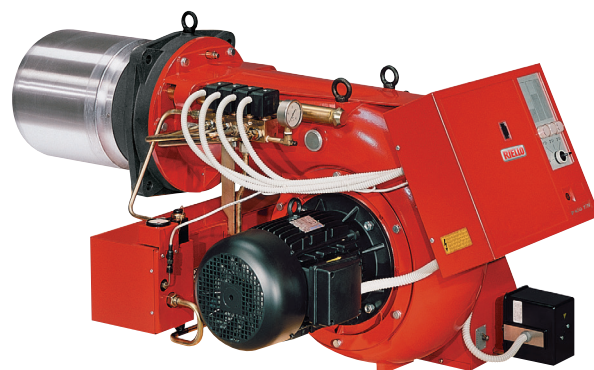

P 140 T/N	320/800 ÷ 1600 kW
P 200 T/N	515/1140 ÷ 2280 kW
P 300 T/N	626/1710 ÷ 3420 kW
P 450 T/N	855/2560 ÷ 5130 kW
P 140 T/N ECO	320/800 ÷ 1600 kW
P 200 T/N ECO	515/1140 ÷ 2280 kW
P 300 T/N ECO	626/1710 ÷ 3420 kW
P 450 T/N ECO	855/2560 ÷ 5130 kW

FIRING RATES

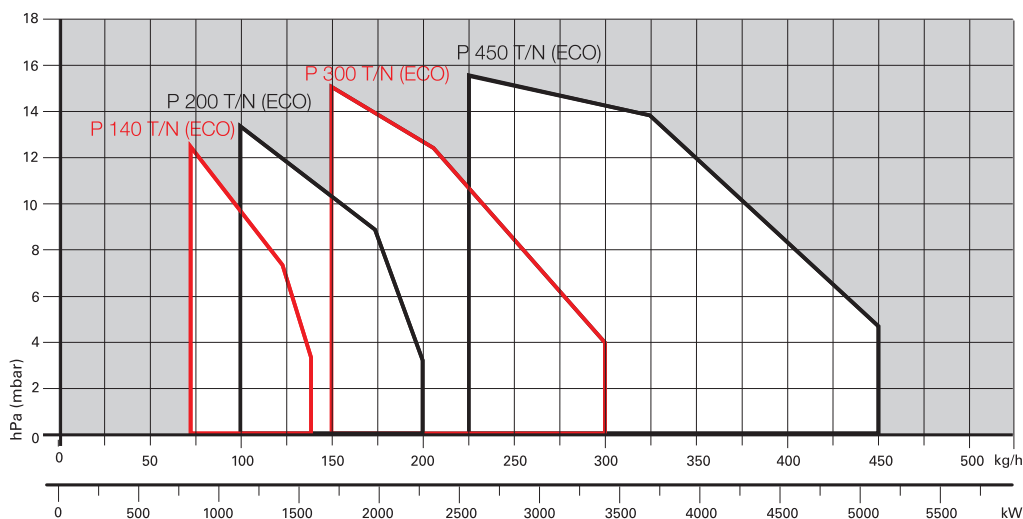

Useful working field for choosing the burner

Test conditions conforming to EN267
 Temperature: 20°C
 Pressure: 1013,5 mbar
 Altitude: 0 m a.s.l.

Three Stage Heavy Oil Burners

PRESS T/N - T/N ECO SERIES

Overall dimensions (mm)

BURNER

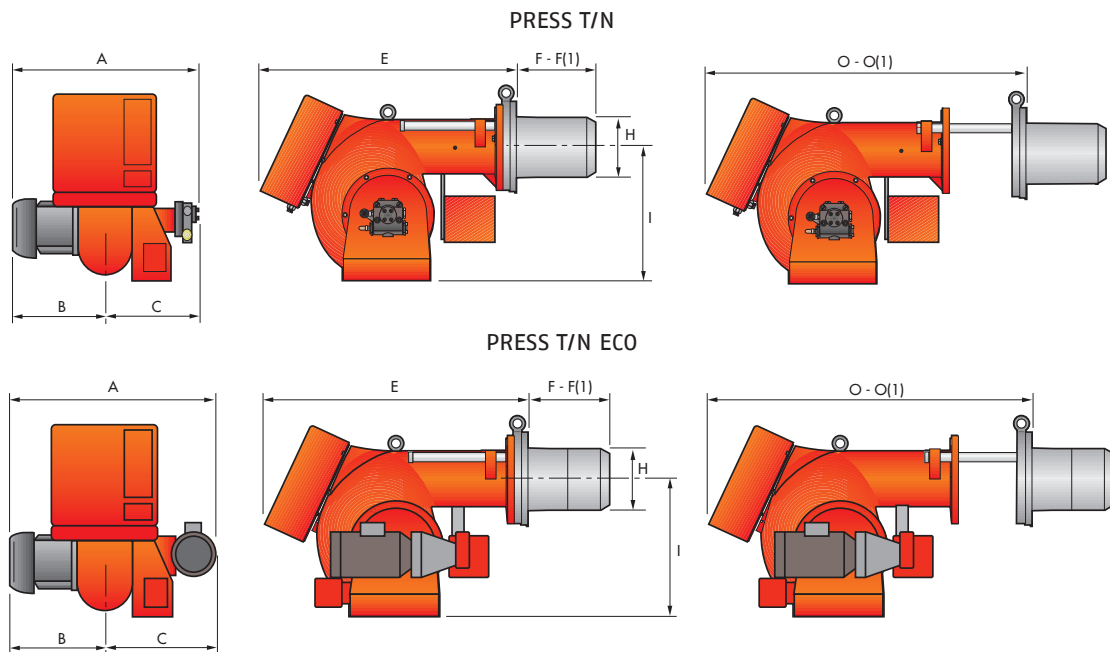

MODEL	A	B	C	E	F - F(1)	H	I	O - O(1)
▶ P 140 T/N	796	396	400	890	323 - 433	222	467	1370 - 1370
▶ P 200 T/N	796	396	400	890	352 - 462	250	467	1370 - 1370
▶ P 300 T/N	858	447	411	1000	376 - 506	295	496	1515 - 1665
▶ P 450 T/N	950	508	442	1090	435 - 565	336	525	1665 - 1820
▶ P 140 T/N ECO	900	396	504	890	323 - 433	222	467	1370 - 1370
▶ P 200 T/N ECO	900	396	504	890	352 - 462	250	467	1370 - 1370
▶ P 300 T/N ECO	984	447	537	1000	376 - 506	295	496	1515 - 1665
▶ P 450 T/N ECO	1100	508	592	1090	435 - 565	336	525	1665 - 1820

(1) Length with extended combustion head

BURNER - BOILER MOUNTING FLANGE

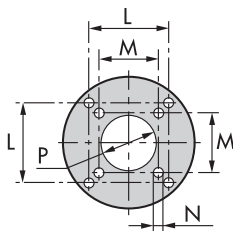

MODEL	L	M	N	P
▶ P 140 T/N (ECO)	260	230	M 14	225
▶ P 200 T/N (ECO)	260	-	M 16	255
▶ P 300 T/N (ECO)	260	-	M 18	300
▶ P 450 T/N (ECO)	310	-	M 20	350

PACKAGING

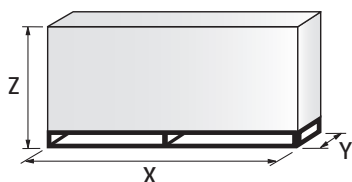

MODEL	X	Y	Z	kg
▶ P 140 T/N (ECO)	1740	990	950	180
▶ P 200 T/N (ECO)	1740	990	950	190
▶ P 300 T/N (ECO)	2040	1180	1125	260
▶ P 450 T/N (ECO)	2040	1180	1125	350

Three Stage Heavy Oil Burners

PRESS T/N - T/N ECO SERIES

RIELLO

Specification

DESIGNATION OF SERIES

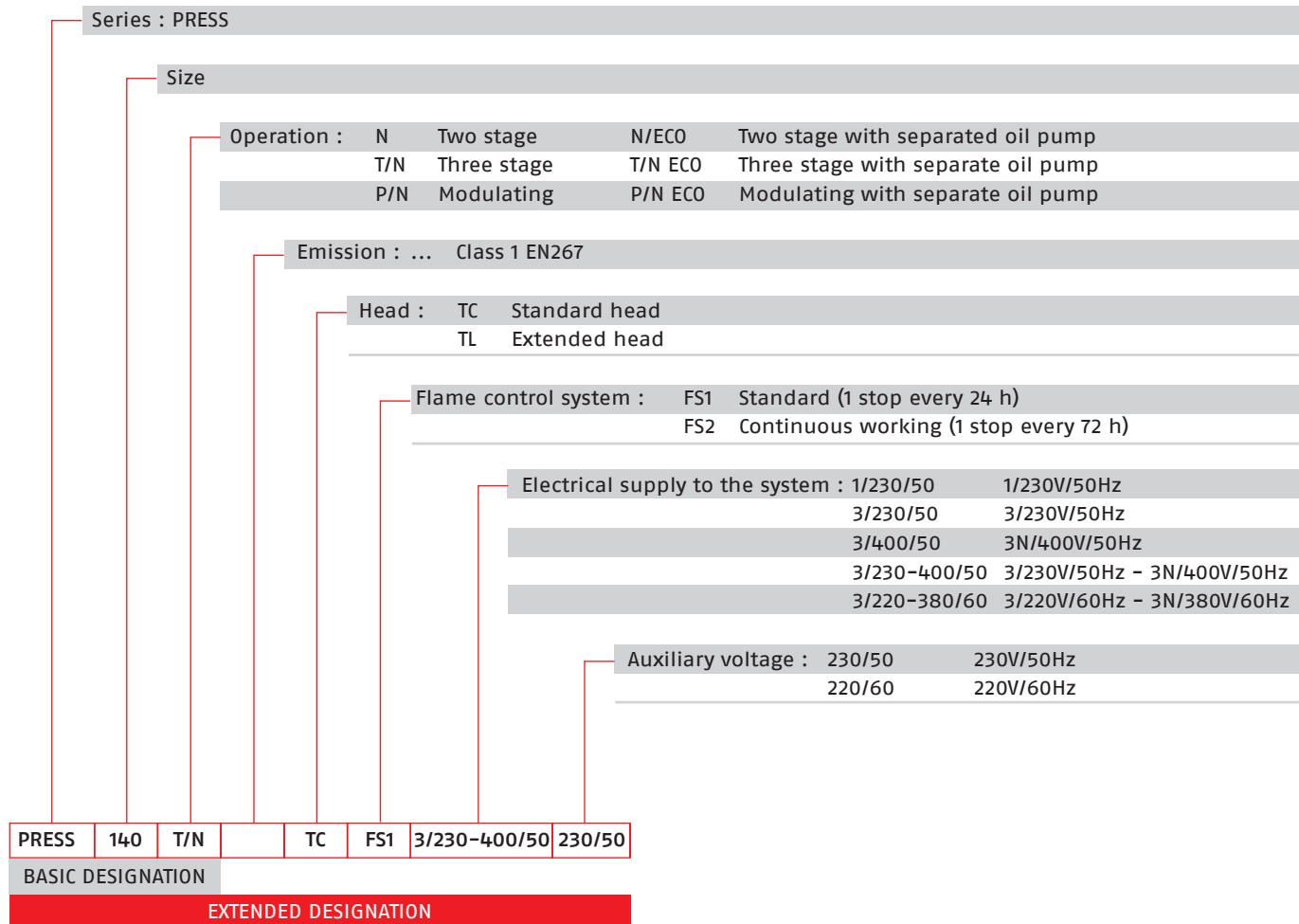

HEAVY OIL

Three Stage Heavy Oil Burners

PRESS T/N - T/N ECO SERIES

Specification

STATE OF SUPPLY

Monoblock forced draught heavy oil burner, three stage operation, made up of:

- Air suction circuit
- Fan with forward curved blades
- Air dampers for air setting controlled by a servomotor
- Fan motor at 2850 rpm
- Combustion head, fitted with:
 - stainless steel end cone, resistant to corrosion and high temperatures
 - ignition electrodes
 - flame stability disk
- Gears pump for high pressure fuel supply, fitted with:
 - filter
 - pressure regulator
 - connections for installing a pressure gauge and vacuumeter
 - internal by-pass for single pipe installation
- Valve unit with a oil safety shut-off valve fitted in series with three valves controlling three-stage on the output circuit
- Heavy oil heating cartridges (T/N ECO version)
- Oil pump motor at 1400 rpm (T/N ECO version)
- Oil preheater
- Servomotor for air damper regulation
- Photocell for flame detection
- Burner safety control box
- Flame inspection window
- Slide bars for easier installation and maintenance
- Protection filter against radio interference
- IP X0D (IP 40) electric protection level.

Standard equipment:

- 2 flexible hoses for pipe connection
- 2 nipples for flexible hoses
- 1 thermal insulation screen
- 4 screws for fixing the burner flange to the boiler
- 3 nozzles
- 2 extensions for bars (for long head version of P 300 T/N and P 450 T/N)
- 5 wiring looms for electrical connections (7 for P 450 T/N version)
- 1 star delta starter (only for P 450 T/N version)
- Instruction handbook for installation, use and maintenance
- Spare parts catalogue.

Three Stage Heavy Oil Burners

PRESS T/N - T/N ECO SERIES

RIELLO

Available models

CODE	MODEL					HEAT OUTPUT		TOTAL ELECTRICAL POWER (kW)	NOTE
						(kW)	(kg/h)		
3436833	PRESS 140 T/N	TC	FS1	3/230-400/50	230/50	320-1600	28-140	19	(3)
3436834	PRESS 140 T/N	TL	FS1	3/230-400/50	230/50	320-1600	28-140	19	
3436885	PRESS 140 T/N	TC	FS1	3/220-380/60	220/60	320-1600	28-140	19	
3436886	PRESS 140 T/N	TL	FS1	3/220-380/60	220/60	320-1600	28-140	19	
3437733	PRESS 200 T/N	TC	FS1	3/230-400/50	230/50	515-2280	45-200	20	
3437734	PRESS 200 T/N	TL	FS1	3/230-400/50	230/50	515-2280	45-200	20	
3437785	PRESS 200 T/N	TC	FS1	3/220-380/60	220/60	515-2280	45-200	20	
3438964	PRESS 300 T/N	TC	FS1	3/400/50	230/50	626-3420	60-300	30	(3)(4)
3438965	PRESS 300 T/N	TL	FS1	3/400/50	230/50	626-3420	60-300	30	(4)
3438968	PRESS 300 T/N	TC	FS1	3/400/50	230/50	626-3420	60-300	30	(1)
3438969	PRESS 300 T/N	TL	FS1	3/400/50	230/50	626-3420	60-300	30	(1)
3808511	PRESS 300 T/N	TC	FS1	3/220-380/60	220/60	626-3420	60-300	30	(1)
3439345	PRESS 450 T/N	TC	FS1	3/230/50	230/50	855-5130	75-450	34	(2)
3439347	PRESS 450 T/N	TC	FS1	3/400/50	230/50	855-5130	75-450	34	(2)
3439348	PRESS 450 T/N	TL	FS1	3/400/50	230/50	855-5130	75-450	34	(2)

(1) Star-delta starting, on board

(2) Star-delta starting, as standard equipment

(3) Nozzle supplied with the burner

(4) For the 3/230/50 version use the 220 - 230 V conversion kit (see the burner accessories paragraph)

Net calorific value: 11,16 kWh/kg; 9600 kcal/kg

Max Viscosity at 50°C for PRESS T/N: 7°E (50 mm²/s, cSt), Type MEDIUM HEAVY OIL / USA n° 4.

Max Viscosity at 50°C for PRESS T/N ECO: 20°E (150 mm²/s, cSt), Type BUNKER B / USA n° 5.

For higher viscosity please contact Riello Burners Technical Department.

The burners of PRESS series are in according to 2014/30/EU - 2014/35/EU - 2006/42 EC Directive and EN 267.

For ECO models ask for specific code.

Special configuration on demand:

- Installed pipes heating cable on PRESS T/N - T/N ECO models, Max Viscosity at 50°C: 60°E (450 mm²/s, cSt), Type BUNKER C / USA no. 6.
- Steam oil pre-heater on T/N ECO models.

Three Stage Heavy Oil Burners

PRESS T/N - T/N ECO SERIES

Burner accessories

Available for T/N and T/N ECO versions

Nozzle type F80 PL 60°



The nozzles must be ordered separately. The following table shows the features and codes on the basis of the maximum required output.

NOTE: each burner needs N° 3 nozzles.

BURNER	RATED DELIVERY (kg/h) at 25 bar	GPH	NOZZLE CODE
▶ P 140 T/N	20,8	3,5	3043162
▶ P 140 T/N	23,8	4	3043172
▶ P 140 T/N	26,8	4,5	3043182
▶ P 140 T/N - P 200 T/N	29,8	5	3043192
▶ P 140 T/N - P 200 T/N	32,7	5,5	3043202
▶ P 140 T/N - P 200 T/N	35,7	6	3043212
▶ P 140 T/N - P 200 T/N	38,7	6,5	3043222
▶ P 140 T/N - P 200 T/N	41,7	7	3043232
▶ P 140 T/N - P 200 T/N	44,6	7,5	3043242
▶ P 200 T/N - P 300 T/N	50,6	8,5	3043262
▶ P 200 T/N - P 300 T/N	56,5	9,5	3043272
▶ P 200 T/N - P 300 T/N - P 450 T/N	62,5	10,5	3043302
▶ P 300 T/N - P 450 T/N	71,4	12	3043322
▶ P 300 T/N - P 450 T/N	80,4	13,5	3043342
▶ P 300 T/N - P 450 T/N	92,3	15,5	3043372
▶ P 450 T/N	104,2	17,5	3043402
▶ P 450 T/N	116,1	19,5	3043432
▶ P 450 T/N	128	21,5	3043452
▶ P 450 T/N	142,8	24	3043472

Extended head kit

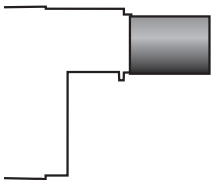

"Standard head" burners can be transformed into "extended head" versions, by using the special kit. The KITS available for the various burners, giving the original and the extended lengths, are listed below.

BURNER	STANDARD HEAD LENGTH (mm)	EXTENDED HEAD LENGTH (mm)	KIT CODE
▶ PRESS 200 T/N	352	462	20047317

Spacer kit

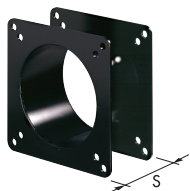

If burner head penetration into the combustion chamber needs reducing, varying thickness spacers are available, as given in the list.

BURNER	SPACER THICKNESS S (mm)	KIT CODE
▶ P 140 T/N - P 200 T/N	102	3000722
▶ P 300 T/N	110	3000723
▶ P 450 T/N	130	3000751

Three Stage Heavy Oil Burners

PRESS T/N - T/N ECO SERIES

RIELLO

Burner accessories

Sound proofing box

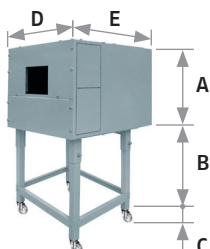

If noise emission needs reducing even further, sound-proofing boxes are available. When a lower "B" dimension is required, it is available the Box Support Kit code 20065135 which allows to reduce it at the fixed dimension of 55 mm. The sound-proofing boxes are not suitable for outdoor use.

BURNER	BOX TYPE	A (mm)	B (mm) min-max	C (mm)	D (mm)	E (mm)	[dB(A)] (*)	BOX CODE
▶ P 140 - 200 T/N	C4/5	850	160 - 980	110	980	930	10	3010404
P 300 - 450 T/N								
▶ P 140 - 200 T/N ECO	C7	1255	160 - 980	110	1140	1345	10	3010376
P 300 - 450 T/N ECO								

(*) Average noise reduction according to EN 15036-1 standard

Self-cleaning filter



For cleaning heavy oil from dirty particles and impurities, it is equipped with a thermostatic heater for oil with 60°E viscosity at 50°C.

FILTER TYPE	FILTERING DEGREE (µm)	FILTER CODE
▶ Ø = 1"1/2 (60°E at 50°C)	300	3010022

HEATER / THERMOSTAT TYPE	HEATER / THERMOSTAT CODE
▶ Thermostatic heater with LED	3010050

Gas separator bottle



Gas separator bottle connects the burner oil circuit to the main ring circuit. It allows to recover heat in excess and discharge return circuit gas.

BURNER	CODE
▶ P 140 T/N - P 200 T/N	3000748
▶ P 300 T/N - P 450 T/N	3010012

Heavy oil kit



Equipped with electrical heaters, it permits the employment of PRESS T/N burners with fuel oil of max. viscosity at 50°C: 20°E (150 mm²/s, cSt), Type BUNKER B / USA n° 5.

BURNER	KIT CODE
▶ P 140 T/N - P 200 T/N - P 300 T/N - P 450 T/N	3000721

Three Stage Heavy Oil Burners

PRESS T/N - T/N ECO SERIES

Burner accessories

Heavy oil precirculation kit



This kit, used with oil with high viscosity, in maintains fuel circulation in the oil circuit for avoiding system stop at start up.

BURNER	KIT CODE
▶ P 140 T/N - P 200 T/N	3000749
▶ P 300 T/N - P 450 T/N	3000750

Burner support

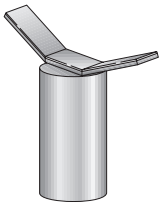

For easier maintenance, a mobile burner support has been designed, which means the burner can be dismantled without the need of forklift trucks.

BURNER	SUPPORT CODE
▶ P 300 T/N - P 450 T/N	3000731

PC Interface kit



To connect the control box to a personal computer for the transmission of operation, fault signals and detailed service information, an interface adapter with PC software are available.

BURNER	KIT CODE
▶ P 140 T/N - P 200 T/N - P 300 T/N - P 450 T/N	3002719

Protection kit (electromagnetic interferences)

When the burner is installed in a room particularly subject to electromagnetic interference (signals emitted over 10 V/m) due for example to INVERTER presence or in systems where the lengths of the thermostat connections is over 20 meters, this specific protection kit is available as an interface between the thermostatic controls and the burner.

BURNER	KIT CODE
▶ All models	3010386

220-230 V conversion kit

This kit is required to convert the 380-400 V models into the 220 or 230 V version.

BURNER	SUPPORT CODE
▶ P 300 T/N	20163347

PRESS P/N - P/N ECO SERIES

The PRESS P/N series of burners covers a firing range from 800 to 5130 kW. They have been designed in three versions for use in commercial and industrial installation, to burn different oil viscosity from 7 up to 60°E @ 50°C.

Operation can be "two stage progressive" or, alternatively, "modulating" with the installation of a PID logic regulator and respective probes, which guarantees a turn down ratio of 3:1.

The versatility of this range makes the burner well suited for use on steam boilers where the load factor is subject to wide variations, on thermal oil boilers and on boilers for particular heating plants, as hospitals or similar.

Simplified maintenance is achieved by the Riello designed slide bar system, which allows easy access to all of the essential components of the combustion head.

Guidelines for installation of burners in conformity to EU Regulation:

A RIELLO burner (Heat Generator), where it is matched with a water-based boiler (Heater Housing) with a nominal output ≤ 400 kW, providing heat for heating purposes and heat to deliver sanitary hot water, can be installed:

- With boilers (heater housings) already in service in the field, for replacement of identical products, in conformity to Article 1, paragraph 2, point (G) of the EU Regulation No. 813/2013;
- With boilers (heater housings) on a new installation.



HEAVY OIL

P 140 P/N	400/800 ÷ 1600 kW
P 200 P/N	570/1140 ÷ 2280 kW
P 300 P/N	683/1710 ÷ 3420 kW
P 450 P/N	1140/2615 ÷ 5130 kW
P 140 P/N ECO	400/800 ÷ 1600 kW
P 200 P/N ECO	570/1140 ÷ 2280 kW
P 300 P/N ECO	683/1710 ÷ 3420 kW
P 450 P/N ECO	1140/2615 ÷ 5130 kW

FIRING RATES

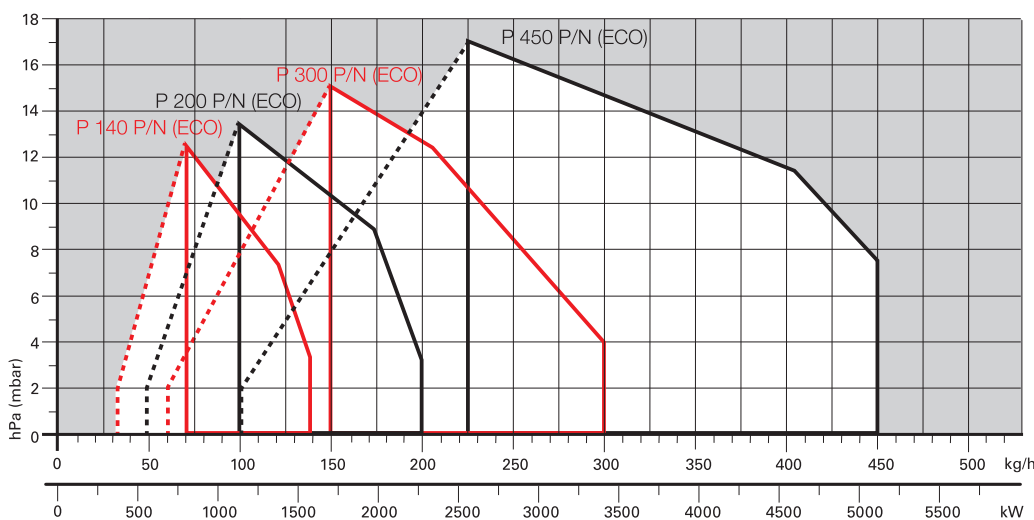

 Useful working field for choosing the burner

 Modulation range

Test conditions conforming to EN267
 Temperature: 20°C
 Pressure: 1013,5 mbar
 Altitude: 0 m a.s.l.

Modulating Heavy Oil Burners

PRESS P/N - P/N ECO SERIES

Overall dimensions (mm)

BURNER

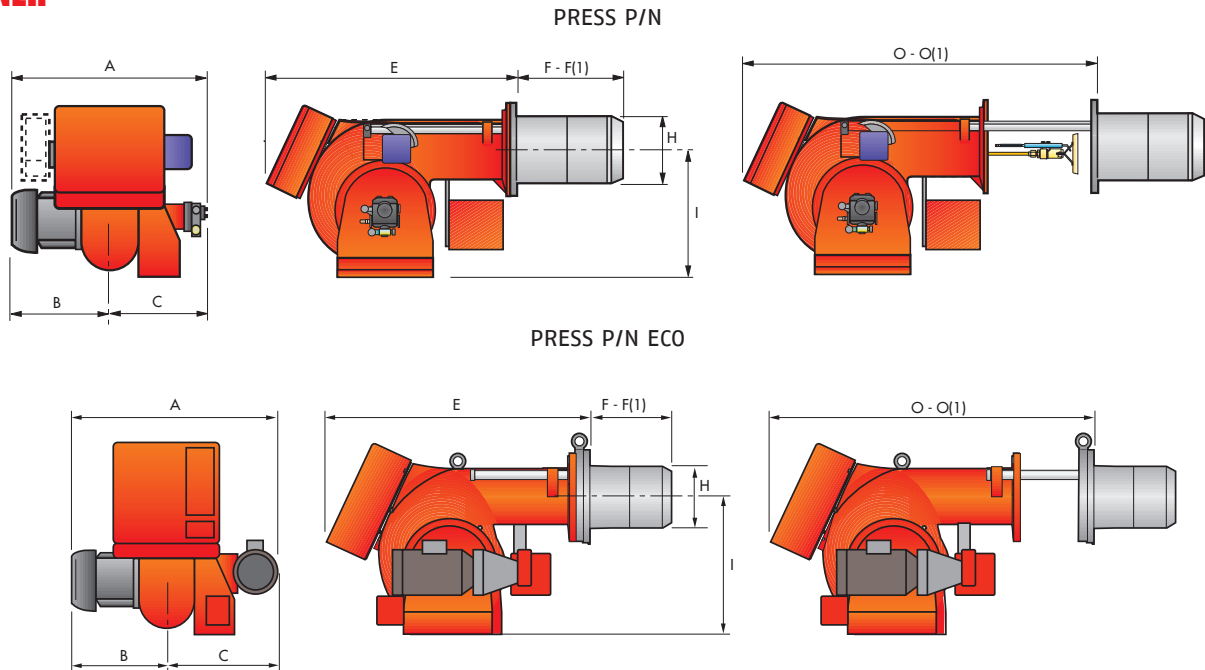

MODEL	A	B	C	E	F - F(1)	H	I	O - O(1)
▶ P 140 P/N	796	396	400	910	323 - 433	222	467	1390 - 1390
▶ P 200 P/N	796	396	400	910	352 - 462	250	467	1390 - 1390
▶ P 300 P/N	858	447	411	1020	376 - 506	295	496	1535 - 1685
▶ P 450 P/N	950	508	442	1090	435 - 565	336	525	1665 - 1820
▶ P 140 P/N ECO	900	396	504	890	323 - 433	222	467	1370 - 1370
▶ P 200 P/N ECO	900	396	504	890	352 - 462	250	467	1370 - 1370
▶ P 300 P/N ECO	984	447	537	1000	376 - 506	295	496	1515 - 1665
▶ P 450 P/N ECO	1100	508	592	1090	435 - 565	336	525	1665 - 1820

(1) Length with extended combustion head

BURNER - BOILER MOUNTING FLANGE

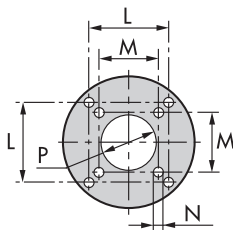

MODEL	L	M	N	P
▶ P 140 P/N (ECO)	260	230	M 14	225
▶ P 200 P/N (ECO)	260	-	M 16	255
▶ P 300 P/N (ECO)	260	-	M 18	300
▶ P 450 P/N (ECO)	310	-	M 20	350

PACKAGING

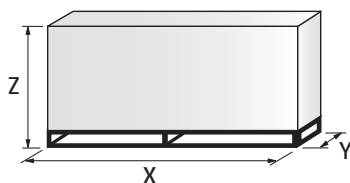

MODEL	X	Y	Z	kg
▶ P 140 P/N (ECO)	1740	990	950	180
▶ P 200 P/N (ECO)	1740	990	950	220
▶ P 300 P/N (ECO)	2040	1180	1125	238
▶ P 450 P/N (ECO)	2040	1180	1125	300

Specification

DESIGNATION OF SERIES

Series : PRESS							
Size							
Operation :		N	Two stage	N/ECO	Two stage with separated oil pump		
		T/N	Three stage	T/N ECO	Three stage with separate oil pump		
		P/N	Modulating	P/N ECO	Modulating with separate oil pump		
Emission :		...	Class 1 EN267				
Head :		TC	Standard head				
		TL	Extended head				
Flame control system :		FS1	Standard (1 stop every 24 h)				
		FS2	Continuous working (1 stop every 72 h)				
Electrical supply to the system :		1/230/50	1/230V/50Hz				
		3/230/50	3/230V/50Hz				
		3/400/50	3N/400V/50Hz				
		3/230-400/50	3/230V/50Hz - 3N/400V/50Hz				
		3/220-380/60	3/220V/60Hz - 3N/380V/60Hz				
Auxiliary voltage :		230/50	230V/50Hz				
		220/60	220V/60Hz				
PRESS	140	P/N		TC	FS1	3/230-400/50	230/50
BASIC DESIGNATION							
EXTENDED DESIGNATION							

Modulating Heavy Oil Burners

PRESS P/N - P/N ECO SERIES

Specification

STATE OF SUPPLY

Monoblock forced draught oil burner with two-stage progressive or modulating operation, with a specific kit, fully automatic, made up of:

- Air suction circuit lined with sound-proofing material
- Fan with forward curved blades high performance pressure levels
- Air damper for air setting and automatic oil output regulator controlled by a servomotor with variable cam
- Fan motor at 2850 rpm, three-phase 400V with neutral, 50Hz
- Combustion head, that can be set on the basis of the combustion output, fitted with:
 - stainless steel end cone, resistant to corrosion and high temperatures
 - ignition electrodes
 - flame stability disk
- Gears pump for high pressure fuel supply, fitted with:
 - filter
 - pressure regulator
 - connections for installing a pressure gauge and vacuumeter
 - internal by-pass for single pipe installation
- Heavy oil heating cartridges (P/N ECO version)
- Pipes heating cable (P/N ECO version)
- Oil pump motor at 1400 rpm (P/N ECO version)
- Valve unit with a double oil safety valve on the output circuit
- Electrical preheater for heavy oil
- Safety oil pressure switch
- Photocell for flame detection
- Burner safety control box, fitted with control function for the correct positioning of the servomotor and possibility of post-ventilation by just changing the electric wiring
- Flame inspection window
- Slide bars for easier installation and maintenance
- Protection filter against radio interference
- IP X0D (IP 40) electric protection level.

Standard equipment:

- 2 flexible pipes for connection to the oil supply network
- 2 nipples for the connection to the pump
- Wiring looms fittings for electrical connections
- 4 screws for fixing the burner flange to the boiler
- 2 slide bar extensions (for the extended head models of P 300 P/N and P 450 P/N)
- Gasket for flange
- Starter*
- Instruction handbook for installation, use and maintenance
- Spare parts catalogue.

* for versions with star-delta starting

PRESS P/N - P/N ECO SERIES

Available models

CODE	MODEL				HEAT OUTPUT		TOTAL ELECTRICAL POWER (kW)	NOTE
					(kW)	(kg/h)		
20169237	P 140 P/N	TC	FS1 3/230-400/50	230/50	400/800÷1600	35/70÷140	19	(5)
20169238	P 140 P/N	TL	FS1 3/230-400/50	230/50	400/800÷1600	35/70÷140	19	(5)
20169239	P 200 P/N	TC	FS1 3/230-400/50	230/50	570/1140÷2280	50/100÷200	20	(5)
20169227	P 200 P/N	TL	FS1 3/230-400/50	230/50	570/1140÷2280	50/100÷200	20	(5)
20169240	P 300 P/N	TC	FS1 3/400/50	230/50	683/1710÷3420	60/150÷300	30	(2)(5)
20169241	P 300 P/N	TC	FS1 3/400/50	230/50	683/1710÷3420	60/150÷300	30	(1)(5)
20169242	P 450 P/N	TC	FS1 3/400/50	230/50	1140/2615÷5130	100/225÷450	34	(1)(5)
20169246	P 450 P/N	TL	FS1 3/400/50	230/50	1140/2615÷5130	100/225÷450	34	(1)(5)

Net calorific value: 11,16 kWh/kg; 9600 kcal/kg

The burners of PRESS series are in according to 2014/30/EU - 2014/35/EU - 2006/42 EC Directive and EN 267.

(1) Star-delta starting

(2) For the 3/230/50 version use the 220 - 230 V conversion kit (see the burner accessories paragraph)

5) with RFGO control box

For ECO models ask for specific code.

Viscosity

The modulating burner P/N series can burn different heavy oil types from 7 up to 60°E @ 50°C (50 up to 450 cSt @ 50°C). For different viscosity levels Riello recommends 3 different configurations:

- 1) PRESS P/N version for viscosity up to 7°E (50 mm²/s, cSt), Type MEDIUM HEAVY OIL / USA n° 4:
basic version with 2800 rpm oil pump installed directly on fan motor shaft (see available codes in the table above)
- 2) PRESS P/N version for viscosity up to 20°E (150 mm²/s, cSt), Type BUNKER B / USA n° 5:
as basic version + heavy oil heating cartridges factory installed on nozzle, pump and valves group (please ask for specific code)
- 3) PRESS P/N ECO version for viscosity up to 20°E (150 mm²/s, cSt), Type BUNKER B / USA n° 5:
with separate 1400 rpm low speed pump, heavy oil heating cartridges factory installed on nozzle, pump and valves group (please ask for specific code)
- 4) PRESS P/N and PRESS P/N ECO versions for viscosity up to 60°E (450 mm²/s, cSt), Type BUNKER C / USA n° 6:
as versions 2) or 3) with pipes heating cable factory installed (please ask for specific code)

Special configuration on demand:

- Steam oil pre-heater on P/N ECO models.

Due to the improvement applied on the technical specification of some products, some burner codes will change during year 2019. The table below summarizes the correspondence between the previous and the new code.

MODEL				NEW CODE		OLD CODE
P 140 P/N	TC	FS1 3/230-400/50	20169237	(5)	3436876	
P 140 P/N	TL	FS1 3/230-400/50	20169238	(5)	3436877	
P 200 P/N	TC	FS1 3/230-400/50	20169239	(5)	3437776	
P 200 P/N	TL	FS1 3/230-400/50	20169227	(5)	3437777	
P 300 P/N	TC	FS1 3/400/50	20169240	(5)	3438987	
P 300 P/N	TC	FS1 3/400/50	20169241	(5)	3438991	
P 450 P/N	TC	FS1 3/400/50	20169242	(5)	3439387	
P 450 P/N	TL	FS1 3/400/50	20169246	(5)	3439388	

Modulating Heavy Oil Burners

PRESS P/N - P/N ECO SERIES

Burner accessories

Available for P/N and P/N ECO versions

Nozzles



The nozzles must be ordered separately. The following table shows the features and codes on the basis of the maximum required output.

NOTE: each burner needs N° 1 nozzle.

BURNER	RATED OUTPUT kg/h	NOZZLES BERGONZO B5 45°- WITH "AA" NEEDLE CODE	NOZZLES FLUIDICS W2 45°- WITH "AA" NEEDLE CODE
▶ P 140 P/N	70	3009203	3045426
▶ P 140 P/N	80	3009205	3045427
▶ P 140 P/N	90	3009207	3045428
▶ P 140 P/N - P 200 P/N	100	3009209	3045430
▶ P 140 P/N - P 200 P/N	125	3009211	3045432
▶ P 200 P/N - P 300 P/N	150	3009213	3045434
▶ P 200 P/N - P 300 P/N	175	3009215	3045436
▶ P 200 P/N - P 300 P/N	200	3009800	3045438
▶ P 200 P/N - P 300 P/N	225	3009801	3045440
▶ P 300 P/N - P 400 P/N	250	3009802	3045442
▶ P 300 P/N - P 400 P/N	275	3009803	3045444
▶ P 300 P/N - P 400 P/N	300	3009804	3045446
▶ P 450 P/N	325	3009805	3045448
▶ P 450 P/N	350	3009806	3045450
▶ P 450 P/N	375	3009807	3045452
▶ P 450 P/N	400	3009808	3045454
▶ P 450 P/N	425	3009809	3045455
▶ P 450 P/N	450	3009810	3045456

Spacer kit

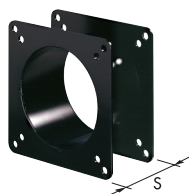

If burner head penetration into the combustion chamber needs reducing, varying thickness spacers are available, as given in the list.

BURNER	SPACER THICKNESS S (mm)	KIT CODE
▶ P 140 P/N - P 200 P/N	102	3000722
▶ P 300 P/N	130	3000723
▶ P 450 P/N	130	3000751

220-230 V conversion kit

This kit is required to convert the 380-400 V models into the 220 or 230 V version.

BURNER	SUPPORT CODE
▶ P 300 P/N	20163347

Burner accessories

Sound proofing box

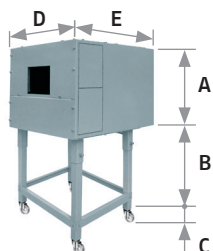

If noise emission needs reducing even further, sound-proofing boxes are available. When a lower "B" dimension is required, it is available the Box Support Kit code 20065135 which allows to reduce it at the fixed dimension of 55 mm. The sound-proofing boxes are not suitable for outdoor use.

BURNER	BOX TYPE	A (mm)	B (mm) min-max	C (mm)	D (mm)	E (mm)	[dB(A)] (*)	BOX CODE
▶ P 140 - 200 P/N P 300 - 450 P/N	C4/5	850	160 - 980	110	980	930	10	3010404
▶ P 140 - 200 P/N ECO P 300 - 450 P/N ECO	C7	1255	160 - 980	110	1140	1345	10	3010376

(*) Average noise reduction according to EN 15036-1 standard

Self-cleaning filter



For cleaning heavy oil from dirty particles and impurities, it is equipped with a thermostatic heater for oil with 60°E viscosity at 50°C.

FILTER TYPE	FILTERING DEGREE (µm)	FILTER CODE
▶ Ø = 1"1/2 (60°E at 50°C)	300	3010022

HEATER / THERMOSTAT TYPE	HEATER / THERMOSTAT CODE
▶ Thermostatic heater with LED	3010050

Gas separator bottle



Gas separator bottle connects the burner oil circuit to the main ring circuit. It allows to recover heat in excess and discharge return circuit gas.

BURNER	CODE
▶ P 140 P/N - P 200 P/N	3000748
▶ P 300 P/N - P 450 P/N	3010012

Heavy oil kit



Equipped with electrical heaters, it permits the employment of PRESS P/N burners with fuel oil of max. viscosity at 50°C: 20°E (150 mm²/s, cSt), Type BUNKER B / USA n° 5.

BURNER	KIT CODE
▶ P 140 P/N - P 200 P/N - P 300 P/N - P 450 P/N	3000721

Modulating Heavy Oil Burners

PRESS P/N - P/N ECO SERIES

Burner accessories

Heavy oil precirculation kit

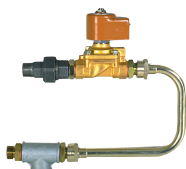

This kit, used with oil with high viscosity, in maintains fuel circulation in the oil circuit for avoiding system stop at start up.

BURNER	KIT CODE
► P 140 P/N - P 200 P/N	3000749
► P 300 P/N - P 450 P/N	3000750

Cartridge filter



For cleaning heavy oil from dirty particles and impurities, it is equipped with a cartridge system equipped with electronic resistance for oil with 7°E viscosity at 50°C.

BURNER	FILTER CODE
► P 140 P/N - P 200 P/N - P 300 P/N - P 450 P/N	3005209

Burner support

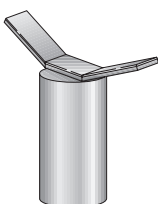

For easier maintenance, a mobile burner support has been designed, which means the burner can be dismantled without the need of forklift trucks.

BURNER	SUPPORT CODE
► P 300 P/N - P 450 P/N	3000731

Accessories for modulating operation



To obtain modulating operation, the PRESS P/N series of burners requires a regulator. For remote setpoint use RWF 55.

BURNER	REGULATOR TYPE	REGULATOR CODE
► P 140 P/N - P 200 P/N - P 300 P/N - P 450 P/N	RWF 50.2	20100018
	RWF 55.5	20101965

The relative temperature or pressure probes fitted to the regulator, must be chosen on the basis of the application.

BURNER	PROBE TYPE	RANGE (°C) (bar)	PROBE CODE
► P 140 - 200 - 300 - 450 P/N	Temperature PT 100	-100 ÷ 500°C	3010110
► P 140 - 200 - 300 - 450 P/N	Pressure 4 ÷ 20 mA	0 ÷ 2,5 bar	3010213
► P 140 - 200 - 300 - 450 P/N	Pressure 4 ÷ 20 mA	0 ÷ 16 bar	3010214
► P 140 - 200 - 300 - 450 P/N	Pressure 4 ÷ 20 mA	0 ÷ 25 bar	3090873

Depending on the servomotor fitted to the burner, a three-pole potentiometer (1000 Ω) can be installed to check the position of the servomotor.

BURNER	POTENTIOMETER KIT CODE
► P 140 P/N - P 200 P/N - P 300 P/N - P 450 P/N	3010021

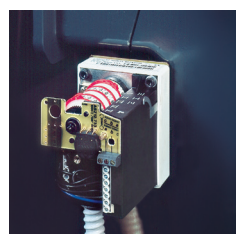

PRESS P/NA - P/NA ECO SERIES

Heavy oil burner series P/NA is an evolution of the traditional heavy oil modulating burners P/N series.

The new range applies a different technology to replace the usual mechanical atomising (high pressure) by "assisted" air/steam atomising (feed pressure 5-8 bar) and taking the related advantages when burning heavy fuels (even vegetal oil).

The upgraded design has been introduced to meet even the worst fuel qualities and to reach anyway the best achievable combustion performance (lower particulate and NOx emissions).

The capacity range is suited to cover applications on steam generators designed for production from 1 to 6 tons/hr of steam or an equivalent capacity in case of other kind of boiler.

Reliable and smooth ignition is achieved by LPG pilot burner installed into the combustion head.

The control system includes all safety and operation interlocks, making possible the configuration compliance to the latest design norms on world-wide base (i.e. EN 267 - UL 296 - others), by the available options on request.

Guidelines for installation of burners in conformity to EU Regulation:

A RIELLO burner (Heat Generator), where it is matched with a water-based boiler (Heater Housing) with a nominal output ≤ 400 kW, providing heat for heating purposes and heat to deliver sanitary hot water, can be installed:

- With boilers (heater housings) already in service in the field, for replacement of identical products, in conformity to Article 1, paragraph 2, point (G) of the EU Regulation No. 813/2013;
- With boilers (heater housings) on a new installation.

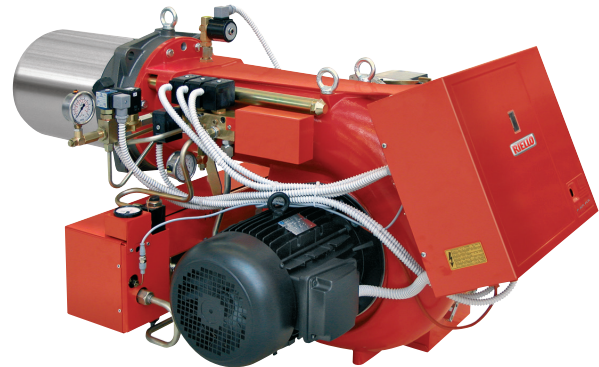

HEAVY OIL

P 140 P/NA	400/800 ÷	1600 kW
P 200 P/NA	570/1140 ÷	2280 kW
P 300 P/NA	683/1710 ÷	3420 kW
P 450 P/NA	1140/2615 ÷	5130 kW
P 140 P/NA ECO	400/800 ÷	1600 kW
P 200 P/NA ECO	570/1140 ÷	2280 kW
P 300 P/NA ECO	683/1710 ÷	3420 kW
P 450 P/NA ECO	1140/2615 ÷	5130 kW

FIRING RATES

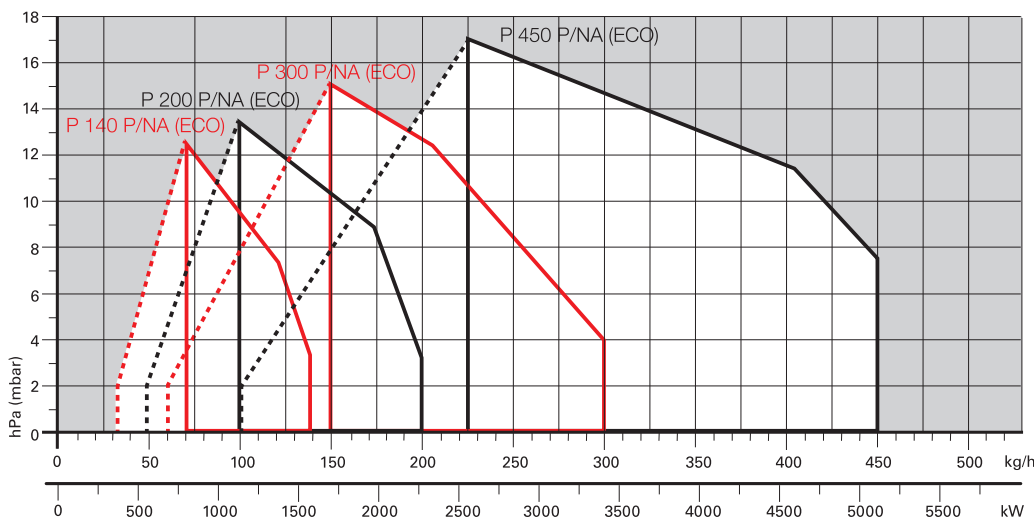

Useful working field for choosing the burner

Modulation range

Test conditions conforming to EN267
 Temperature: 20°C
 Pressure: 1013,5 mbar
 Altitude: 0 m a.s.l.

Modulating Heavy Oil Burners with Air/Steam Atomizing

PRESS P/NA - P/NA ECO SERIES

Overall dimensions (mm)

BURNER

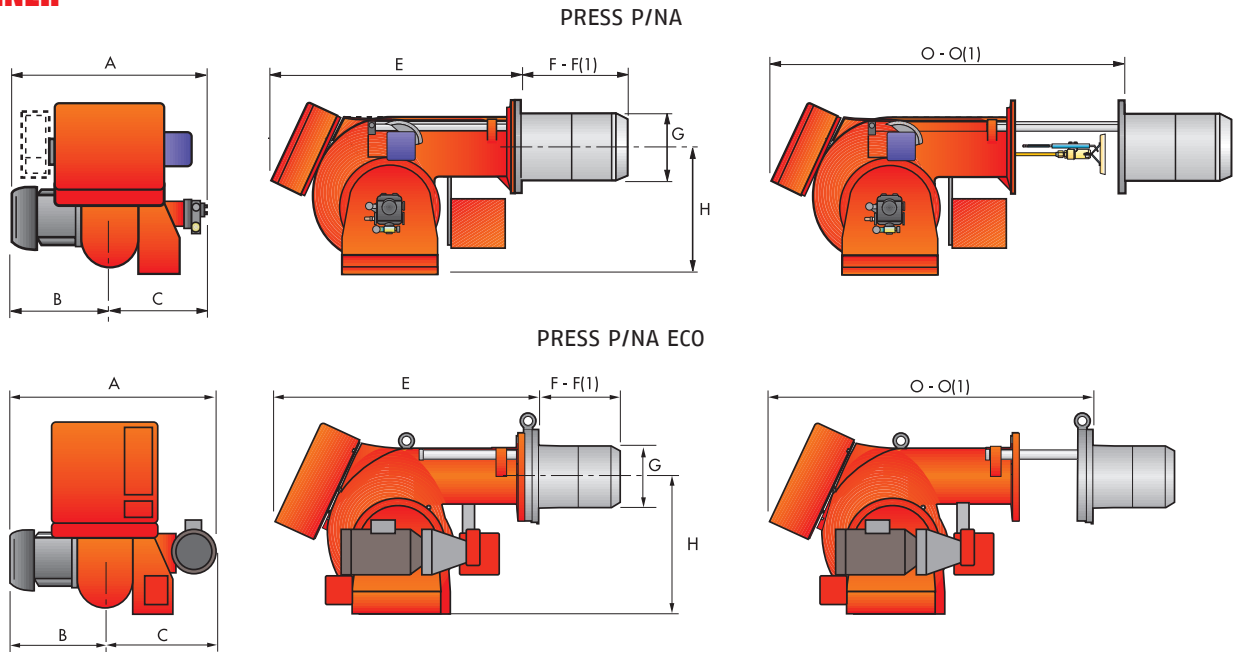

MODEL	A	B	C	E	F - F(1)	G	H	O - O(1)
▶ P 140 P/NA	796	396	400	910	323 - 433	222	467	1390 - 1390
▶ P 200 P/NA	796	396	400	910	352 - 462	250	467	1390 - 1390
▶ P 300 P/NA	858	447	411	1020	376 - 506	295	496	1535 - 1685
▶ P 450 P/NA	950	508	442	1090	435 - 565	336	525	1665 - 1820
▶ P 140 P/NA ECO	900	396	504	890	323 - 433	222	467	1370 - 1370
▶ P 200 P/NA ECO	900	396	504	890	352 - 462	250	467	1370 - 1370
▶ P 300 P/NA ECO	984	447	537	1000	376 - 506	295	496	1515 - 1665
▶ P 450 P/NA ECO	1100	508	592	1090	435 - 565	336	525	1665 - 1820

(1) Length with extended combustion head

BURNER - BOILER MOUNTING FLANGE

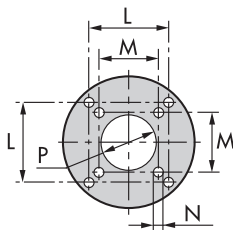

MODEL	L	M	N	P
▶ P 140 P/NA (ECO)	260	230	M 14	225
▶ P 200 P/NA (ECO)	260	-	M 16	255
▶ P 300 P/NA (ECO)	260	-	M 18	300
▶ P 450 P/NA (ECO)	310	-	M 20	350

PACKAGING

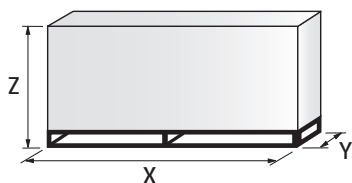

MODEL	X	Y	Z	kg
▶ P 140 P/NA (ECO)	1740	990	950	180
▶ P 200 P/NA (ECO)	1740	990	950	220
▶ P 300 P/NA (ECO)	2040	1080	1125	238
▶ P 450 P/NA (ECO)	2040	1080	1125	300

Modulating Heavy Oil Burners with Air/Steam Atomizing

PRESS P/NA - P/NA ECO SERIES

RIELLO

Specification

DESIGNATION OF SERIES

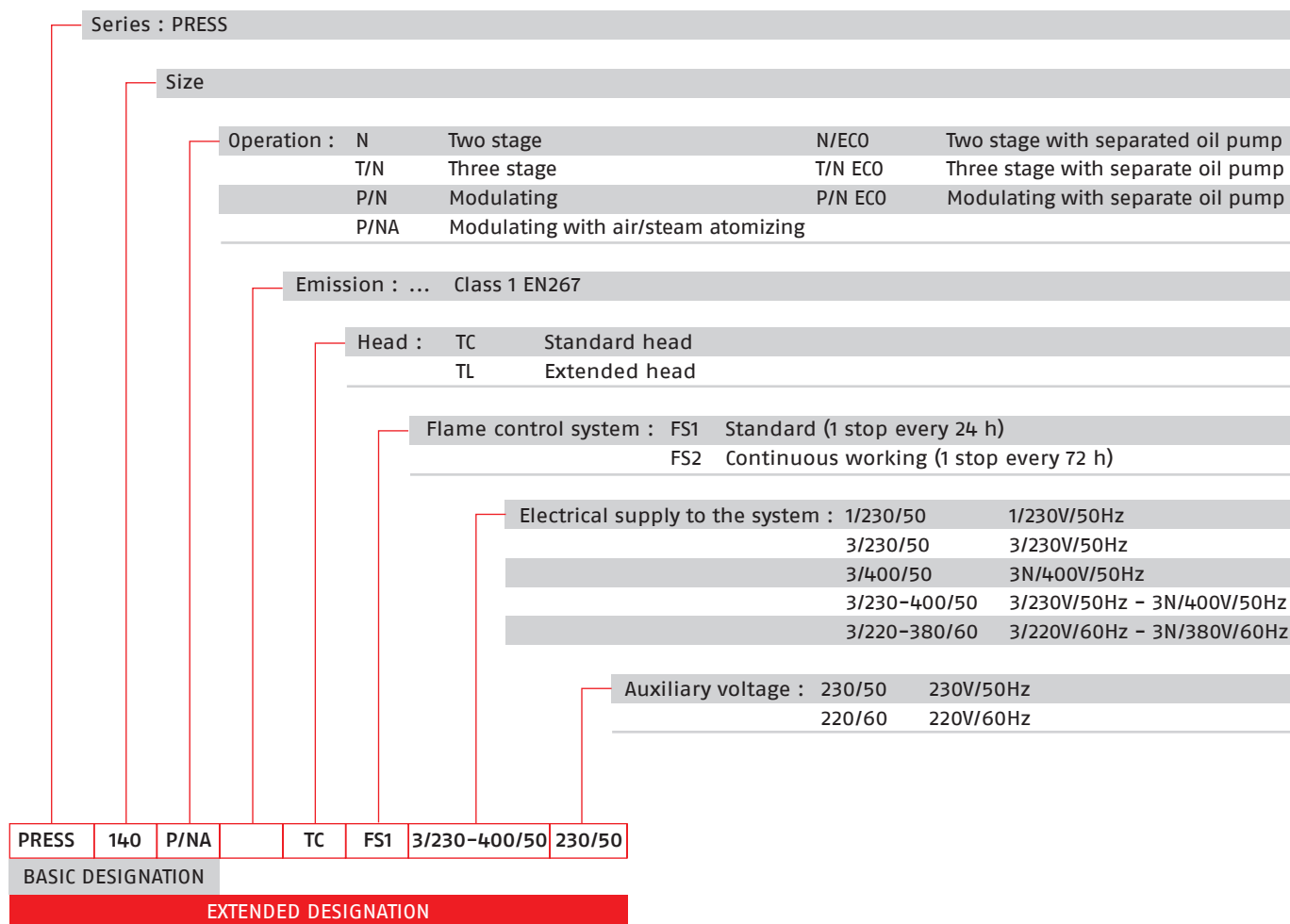

HEAVY OIL

Modulating Heavy Oil Burners with Air/Steam Atomizing

PRESS P/NA - P/NA ECO SERIES

Specification

STATE OF SUPPLY

Monoblock forced draught oil burner with two-stage progressive or modulating operation, with a specific kit, fully automatic, made up of:

- Air suction circuit lined with sound-proofing material
- Fan with forward curved blades high performance pressure levels
- Air damper for air setting and automatic oil output regulator controlled by a servomotor with variable cam
- Fan motor at 2850 rpm, three-phase 400V with neutral, 50Hz
- Combustion head, that can be set on the basis of the combustion output, fitted with:
 - stainless steel end cone, resistant to corrosion and high temperatures
 - ignition electrodes
 - flame stability disk
- Gears pump for high pressure fuel supply, fitted with:
 - filter
 - pressure regulator
 - connections for installing a pressure gauge and vacuumeter
 - internal by-pass for single pipe installation
- Heavy oil kit cartridges
- Pipes heating cable (P/NA ECO version)
- Oil pump motor at 1400 rpm (P/NA ECO version)
- Valve unit with a double oil safety valve on the output circuit
- LPG pilot burner ignition
- Electrical preheater for heavy oil
- Safety oil pressure switch
- Photocell for flame detection
- Burner safety control box, fitted with control function for the correct positioning of the servomotor and possibility of post-ventilation by just changing the electric wiring
- Flame inspection window
- Slide bars for easier installation and maintenance
- Protection filter against radio interference
- IP X0D (IP 40) electric protection level.

Standard equipment:

- 2 flexible pipes for connection to the oil supply network
- 2 nipples for the connection to the pump
- Wiring looms fittings for electrical connections
- 4 screws for fixing the burner flange to the boiler
- 2 slide bar extensions (for the extended head models of P 300 P/NA and P 450 P/NA)
- Gasket for flange
- Starter*
- Instruction handbook for installation, use and maintenance
- Spare parts catalogue.

* for versions with star-delta starting

PRESS P/NA - P/NA ECO SERIES

Available models

CODE	MODEL	HEAT OUTPUT		TOTAL ELECTRICAL POWER (kW)	NOTE
		(kW)	(kg/h)		
On demand	P 140 P/NA TC 3/230-400/50 230/50	400/800-1600	33,7/67,4-134,9	11,5	
On demand	P 140 P/NA TC 3/220-380/60 220/60	400/800-1600	33,7/67,4-134,9	11,5	
3808516	P 200 P/NA TC 3/230-400/50 230/50	570/1140-2280	48/96,12-192,2	12,5	
On demand	P 200 P/NA TC 3/220-380/60 220/60	570/1140-2280	48/96,12-192,2	12,5	
On demand	P 300 P/NA TC 3/230-400/50 230/50	683/1710-3420	57,6/144,1-288,3	25	
On demand	P 300 P/NA TC 3/220-380/60 220/60	683/1710-3420	57,6/144,1-288,3	25	
3808519	P 450 P/NA TC 3/400/50 230/50	1140/2615-5130	96,1/220,5-432,6	37	
On demand	P 450 P/NA TC 3/380/60 220/60	1140/2615-5130	96,1/220,5-432,6	37	

Net calorific value: 11,16 kWh/kg; 9600 kcal/kg

The burners of PRESS series are in according to 2014/30/EU - 2014/35/EU - 2006/42 EC Directive and EN 267.

For ECO model, ask for specific code.

Viscosity

The modulating burner P/NA series can burn different heavy oil types from 50 up to 600 cSt @ 50°C (up to 80°E @ 50°C).

For different viscosity levels Riello recommends 3 different configurations:

- 1) PRESS P/NA version for viscosity up to 60°E (450 mm²/s, cSt), Type BUNKER C / USA n° 6:
 - with 2800 rpm oil pump installed directly on fan motor shaft
 - heavy oil heating cartridges factory installed on nozzle, pump and valves group (see available codes in the table above)
- 2) PRESS P/NA ECO version for viscosity up to 60°E (450 mm²/s, cSt), Type BUNKER C / USA n° 6:
 - with separate 1400 rpm low speed pump
 - heavy oil heating cartridges factory installed on nozzle, pump and valves group (please ask for specific code)
- 3) PRESS P/NA and PRESS P/NA ECO versions for viscosity up to 80°E (600 mm²/s, cSt), Type CHINESE OIL n° 60: as versions 1) or 2) with pipes heating cable factory installed (please ask for specific code)

Special configuration on demand:

- Steam oil pre-heater on P/NA ECO models.

Modulating Heavy Oil Burners with Air/Steam Atomizing

PRESS P/NA - P/NA ECO SERIES

Burner accessories

Available for P/NA and P/NA ECO versions

Y-jet air/steam atomising nozzles - type 15 AG 45°



Effective nozzle delivery depends from many factors. Particular small variations of air/steam atomising pressure or viscosity at the nozzle, cause big oil delivery variations. Therefore, to choose the right nozzle it is so necessary to consider all parameters listed in the table below.

NOZZLE 15 AG 45°	VISCOSITY @ NOZZLE	OIL DENSITY	OIL DELIVERY (kg/h)					AIR CONSUMPTION AT 4 bar (kg/h)		SUGGESTED AIR/ STEAM PRESSURE	CODE
			cSt	kg/m ³	6 bar	5 bar	4 bar	3 bar	2 bar		
▶ 60	5	850	112	94	75	60	32	2,5	8,4	2	3045000
	10	875	95	80	60	41	20	5,9	13,9	3	
	20	900	75	60	42	25	n.a.*	10	20	4	
	30	925	68	55	36	20	n.a.*	11,3	21,7	4	
▶ 70	5	850	130	110	90	70	36	2,9	9,9	2	3045001
	10	875	111	95	78	48	25	6,8	16	3	
	20	900	88	70	50	30	n.a.*	11,9	23	4	
	30	925	80	64	44	24	n.a.*	13,2	25,4	4	
▶ 80	5	850	150	130	105	80	40	3,3	11,3	2	3045002
	10	875	127	108	85	55	30	7,8	18,3	3	
	20	900	100	80	55	35	n.a.*	13,6	26,2	4	
	30	925	91	73	51	30	n.a.*	15	28,9	4	
▶ 100	5	850	187	158	130	100	50	4,2	14	2	3045003
	10	875	158	135	100	70	35	9,8	22,8	3	
	20	900	126	105	70	40	n.a.*	17	32,7	4	
	30	925	114	91	65	35	n.a.*	18,8	34,2	4	
▶ 130	5	850	243	200	170	130	60	5,4	18,3	2	3045004
	10	875	206	173	130	95	40	12,7	29,7	3	
	20	900	163	131	90	55	n.a.*	22	42,6	4	
	30	925	148	118	82	45	n.a.*	24,4	47	4	
▶ 160	5	850	299	260	210	160	80	6,7	22,5	2	3045005
	10	875	253	215	170	115	50	15,7	36,5	3	
	20	900	201	161	115	65	n.a.*	27,1	52,4	4	
	30	925	182	145	102	58	n.a.*	30	57,9	4	
▶ 200	5	850	374	330	260	215	105	8,3	28,1	2	3045006
	10	875	317	270	215	145	60	19,6	45,7	3	
	20	900	252	203	140	85	n.a.*	33,9	65,5	4	
	30	925	228	182	120	70	n.a.*	37,5	72,4	4	
▶ 225	5	850	421	365	285	220	110	9,4	31,7	2	3045007
	10	875	357	311	240	160	70	22,1	51,4	3	
	20	900	280	225	156	100	n.a.*	38,2	73,7	4	
	30	925	256	205	141	60	n.a.*	42,2	81,4	4	
▶ 250	5	850	468	410	340	250	120	10,4	35,2	2	3045008
	10	875	396	340	270	180	80	24,5	57,1	3	
	20	900	315	252	175	110	n.a.*	42,4	81,9	4	
	30	925	285	228	150	85	n.a.*	46,8	90,5	4	
▶ 275	5	850	514	430	360	270	130	11,5	38,6	2	3045009
	10	875	436	365	300	190	85	27	62,8	3	
	20	900	346	277	193	120	n.a.*	46,7	90	4	
	30	925	313	250	175	95	n.a.*	51,6	99,5	4	
▶ 300	5	850	560	470	400	300	150	11,5	38,6	2	3045010
	10	875	476	410	340	200	90	29,3	68,5	3	
	20	900	378	302	210	130	n.a.*	51	98,2	4	
	30	925	342	273	190	100	n.a.*	56,3	108,6	4	

* This matching is not available.

Burner accessories

Spacer kit

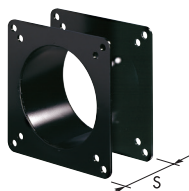

If burner head penetration into the combustion chamber needs reducing, varying thickness spacers are available, as given in the list.

BURNER	SPACER THICKNESS S (mm)	KIT CODE
▶ P 140 P/NA - P 200 P/NA	102	3000722
▶ P 300 P/NA	130	3000723
▶ P 450 P/NA	130	3000751

Sound proofing box

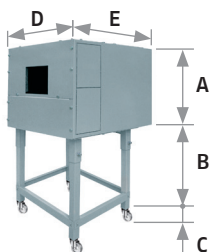

If noise emission needs reducing even further, sound-proofing boxes are available. When a lower "B" dimension is required, it is available the Box Support Kit code 20065135 which allows to reduce it at the fixed dimension of 55 mm. The sound-proofing boxes are not suitable for outdoor use.

BURNER	BOX TYPE	A (mm)	B (mm) min-max	C (mm)	D (mm)	E (mm)	[dB(A)] (*)	BOX CODE
▶ P 140 - 200 P/NA	C4/5	850	160 - 980	110	980	930	10	3010404
▶ P 300 - 450 P/NA	C7	1255	160 - 980	110	1140	1345	10	3010376

(*) Average noise reduction according to EN 15036-1 standard

Self-cleaning filter



For cleaning heavy oil from dirty particles and impurities, it is equipped with a thermostatic heater for oil with 60°E viscosity at 50°C.

FILTER TYPE	FILTERING DEGREE (µm)	FILTER CODE
▶ Ø = 1"1/2 (60°E at 50°C)	300	3010022

HEATER / THERMOSTAT TYPE	HEATER / THERMOSTAT CODE
▶ Thermostatic heater with LED	3010050

Cartridge filter



For cleaning heavy oil from dirty particles and impurities, it is equipped with a cartridge system equipped with electronic resistance for oil with 7°E viscosity at 50°C.

BURNER	FILTER CODE
▶ P 140 P/NA - P 200 P/NA - P 300 P/NA - P 450 P/NA	3005209

Modulating Heavy Oil Burners with Air/Steam Atomizing

PRESS P/NA - P/NA ECO SERIES

Burner accessories

Gas separator bottle



Gas separator bottle connects the burner oil circuit to the main ring circuit. It allows to recover heat in excess and discharge return circuit gas.

BURNER	CODE
▶ P 140 P/NA - P 200 P/NA	3000748
▶ P 300 P/NA - P 450 P/NA	3010012

Burner support

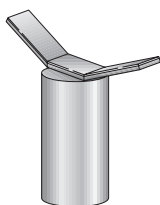

For easier maintenance, a mobile burner support has been designed, which means the burner can be dismantled without the need of forklift trucks.

BURNER	SUPPORT CODE
▶ P 300 P/NA - P 450 P/NA	3000731

Accessories for modulating operation



To obtain modulating operation, the PRESS P/NA series of burners requires a regulator.

BURNER	REGULATOR TYPE	REGULATOR CODE
▶ P 140 P/NA - P 200 P/NA - P 300 P/NA - P 450 P/NA	RWF 50.2	20100018
	RWF 55.5	20101965



The relative temperature or pressure probes fitted to the regulator, must be chosen on the basis of the application.

BURNER	PROBE TYPE	RANGE (°C) (bar)	PROBE CODE
▶ P 140 - 200 - 300 - 450 P/NA	Temperature PT 100	-100 ÷ 500°C	3010110
▶ P 140 - 200 - 300 - 450 P/NA	Pressure 4 ÷ 20 mA	0 ÷ 2,5 bar	3010213
▶ P 140 - 200 - 300 - 450 P/NA	Pressure 4 ÷ 20 mA	0 ÷ 16 bar	3010214
▶ P 140 - 200 - 300 - 450 P/NA	Pressure 4 ÷ 20 mA	0 ÷ 25 bar	3090873



Depending on the servomotor fitted to the burner, a three-pole potentiometer (1000 Ω) can be installed to check the position of the servomotor.

BURNER	POTENTIOMETER KIT CODE
▶ P 140 P/NA - P 200 P/NA - P 300 P/NA - P 450 P/NA	3010021

Burner accessories

Gas/LPG Pressure regulator and SSOV for pilot burner (inlet pressure 0,5-7 bar)

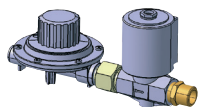

To be applied on gas/LPG bottle when not already available.

TYPE	CODE
▶ HPR 1910	3010405

Steam valve over 10 bar or 180°C



To be applied for pressure from 10 to 15 bar or temperature from 180°C to maximum 200°C.

TYPE	CODE
▶ ODE	-

Water separator bottle



To be installed on the air/steam supply line in order to prevent water droplets to the nozzle supply.

TYPE	CODE
▶ WSB	-

GULLIVER BS SERIES

The Riello Gulliver BS series of one stage gas burners, is a complete range of Low NOx emission products, developed to respond to any request for home heating, conforming to the most severe standards regarding the reduction of polluting emissions.

This series of burners is available in four different models with an output ranging from 16 to 250 kW, divided in four different structures.

All the models use the same components designed by Riello for the Gulliver series. The high quality level guarantees safe working. The burners are fitted with a microprocessor-based burner safety control box which supplies indication of operation and diagnosis of fault cause.

In developing these burners, special attention was paid to reducing noise, the ease of installation and adjustment, to obtaining the smallest size possible to fit into any sort of boiler available on the market.

All the models are approved by the EN 676 European Standard and conform to European Directives, Gas Appliance, EMC, Low Voltage, Boiler Efficiency.

All the Gulliver BS burners are tested before leaving the factory.

Guidelines for installation of burners in conformity to EU Regulation:

A RIELLO burner (Heat Generator), where it is matched with a water-based boiler (Heater Housing) with a nominal output ≤ 400 kW, providing heat for heating purposes and heat to deliver sanitary hot water, can be installed:

- With boilers (heater housings) already in service in the field, for replacement of identical products, in conformity to Article 1, paragraph 2, point (G) of the EU Regulation No. 813/2013;
- With boilers (heater housings) on a new installation.



BS1	16 ÷ 52	kW
BS2	35 ÷ 92	kW
BS3	65 ÷ 197	kW
BS4	110 ÷ 249	kW

FIRING RATES

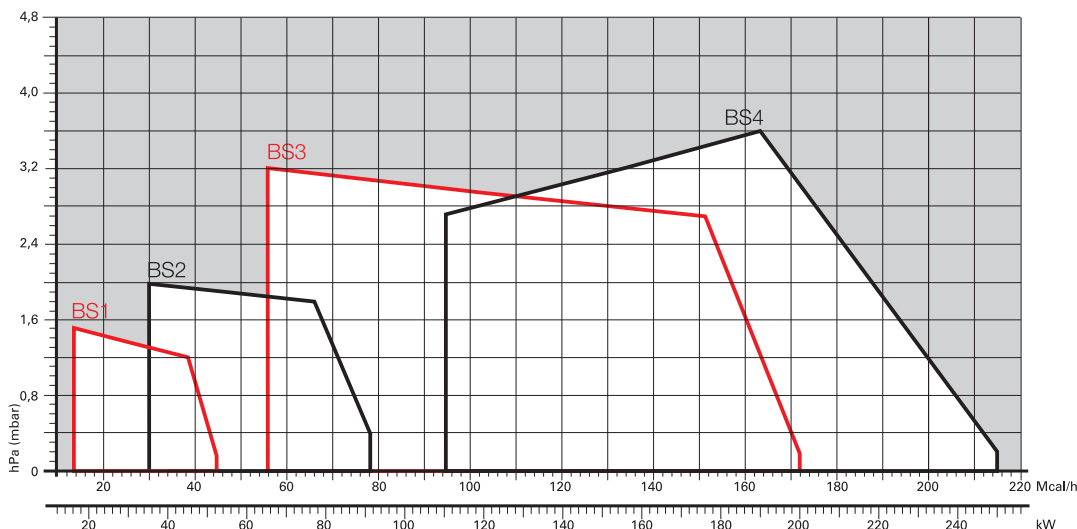

Useful working field for choosing the burner

Test conditions conforming to EN676
 Temperature: 20°C
 Pressure: 1013,5 mbar
 Altitude: 0 m a.s.l.

Low NOx One Stage Gas Burners

GULLIVER BS SERIES

Overall dimensions (mm)

BURNER

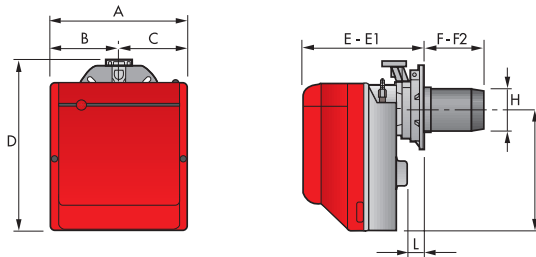

MODEL	A	B	C	D	E	E1	F	F2	H	I	L
► BS1	234	122	112	295	230	276	116	70	89	210	41
► BS2	255	125,5	125,5	325	238	252	114	100	106	230	45
► BS2 TL	255	125,5	125,5	325	238	252	184	170	106	230	45
► BS3	300	150	150	391	262	280	128	110	129	285	45
► BS3 TL	300	150	150	391	262	280	285	267	129	285	45
► BS4	300	150	150	392	278	301	168	145	137	286	45
► BS4 TL	300	150	150	392	278	301	325	302	137	286	45

BURNER - BOILER MOUNTING FLANGE

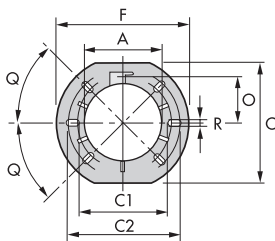

MODEL	A	C	C1	C2	F	O	Q	R
► BS1	89	167	140	170	192	66	45°	11
► BS2 - BS2 TL	106	167	140	170	192	66	45°	11
► BS3 - BS3 TL	129	201	160	190	216	76,5	45°	11
► BS4 - BS4 TL	137	203	170	200	218	80,5	45°	11

PACKAGING

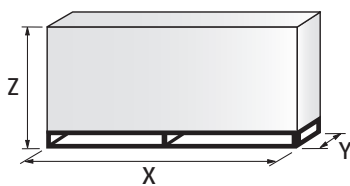

MODEL	X	Y	Z	kg
BS1	395	278	350	10
BS2	405	298	375	11
BS2 TL	583	290	370	11 - 13
BS3	450	345	440	15
BS3 TL	703	335	435	15 - 17
BS4	510	345	440	16,5
BS4 TL	703	335	435	16,5 - 18,5

GULLIVER BS SERIES

Specification

DESIGNATION OF SERIES

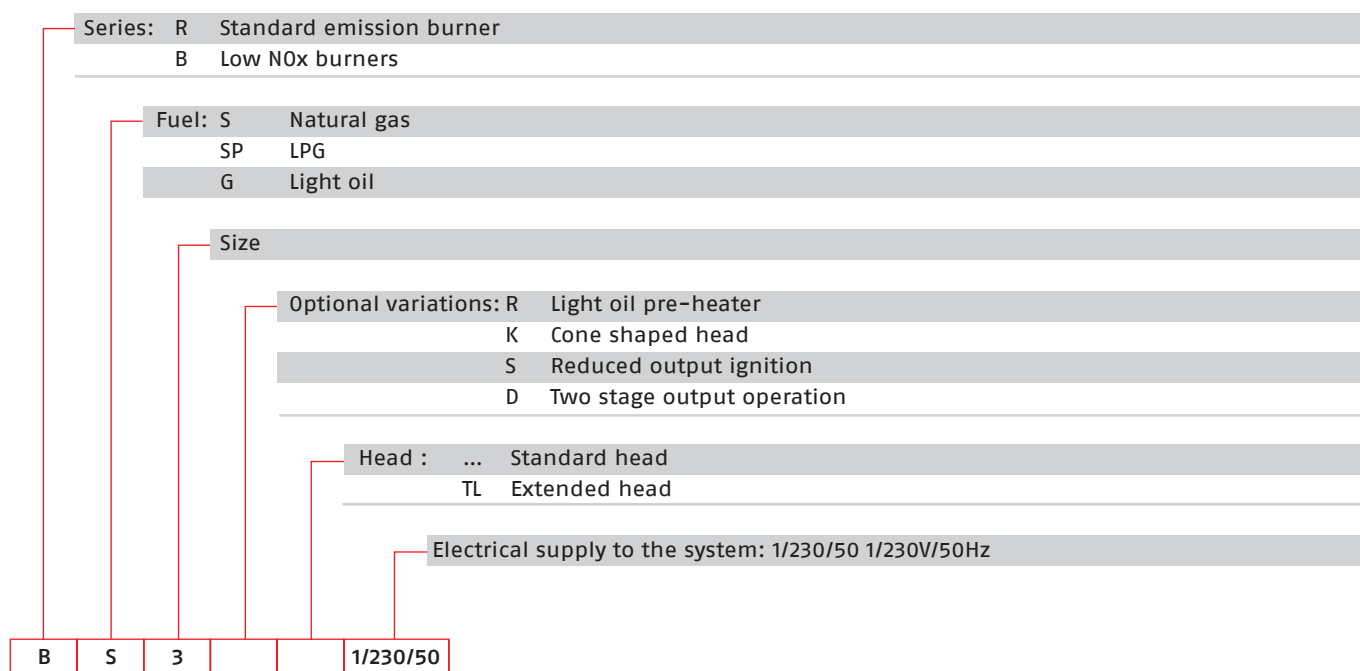

STATE OF SUPPLY

Monoblock, gas burners, completely automatic, one stage operation, made up of:

- Fan with forward curve blades
- Cover lined with sound-proofing material
- Air damper, completely closed in stand by, with external adjustment, with no need to remove the cover
- Single phase electric motor 230 V, 50 Hz
- Combustion head fitted with:
 - stainless steel head cone, resistant to high temperatures
 - ignition electrodes
 - ionisation probe
 - gas distributor
 - flame stability disk
- Flame inspection window
- Adjustable air pressure switch, with graduated selector, to guarantee burner lock out in the case of insufficient combustible air
- Microprocessor-based burner safety control box, with diagnostic and remote reset functions
- Protection filter against radio interference (included into burner safety control box)
- IP X0D (IP 40) electric protection level.

Standard equipment:

- Sliding flange
- Flange insulation screen
- Screws and nuts for fixing the flange to the boiler
- 7-pin plug
- Remote control release kit
- Instruction handbook for installation, use and maintenance
- Spare parts catalogue.

Low NOx One Stage Gas Burners

GULLIVER BS SERIES

Available models

Burners

CODE	MODEL	HEAT OUTPUT		TOTAL ELECTRICAL POWER (kW)	CERTIFICATION	NOTE
		(kW)	NATURAL GAS (Nm ³ /h)			
3761158	BS1 1/230/50	16 - 52	1,6 - 5,2	0,150	CE - 0085 AQ0409	(1)
3761258	BS2 1/230/50	35 - 92	3,5 - 9,1	0,180	CE - 0085 AQ0409	(1)
20052601	BS2 TL 1/230/50	35 - 92	3,5 - 9,1	0,180	CE - 0085 AQ0409	(1)
3761358	BS3 1/230/50	65 - 197	6,5 - 20	0,350	CE - 0085 AQ0409	(1)
20052611	BS3 TL 1/230/50	65 - 197	6,5 - 20	0,350	CE - 0085 AQ0409	(1)
3761458	BS4 1/230/50	110 - 249	11 - 25	0,530	CE - 0085 AQ0409	(1)
20052612	BS4 TL 1/230/50	110 - 249	11 - 25	0,530	CE - 0085 AQ0409	(1)

Net calorific value G20: 10 kWh/Nm³ - Density: 0,71 kg/Nm³.

The burners of BS series are in according to 2016/426/EU - 2014/30/EU - 2014/35/EU - 2006/42 EC Directive and EN 676.

(1) With plug and socket.

Gas Trains

	GAS TRAIN		NATURAL GAS		LPG		NOTE
	CODE *	MODEL	BURNER (type)	ADAPTER (code)	BURNER (type)	ADAPTER (code)	
MULTIBLOC	3970570	MBC 65/1 - F1SD 20	BS1		BS1		(1)
	3970546	MB 405/1 - F1SD 20	BS1		BS1		(1)
	3970547	MB 405/1 - F2SD 20	BS2		BS2		(1)
	3970544	MB 407/1 - F2SD 20	BS2		BS2		(1)
	3970548	MB 407/1 - F3SD 20	BS3 - BS4		BS3 - BS4		(1)
	3970549	MB 410/1 - F3SD 20	BS3 - BS4		BS3 - BS4		(1)
	3970550	MB 412/1 - F3SD 20	BS3 - BS4		BS3 - BS4		(1)

Please see Designation of Gas Train Series in the page before the Catalogue index.

* Gas trains are 230V/50Hz - 220V/60Hz electrical supply.

(1) With installed plug.

The valve seal control device is compulsory (conforming to EN 676) on gas trains to burners with a maximum output over 1200 kW.

To select the gas train please refer to the technical data leaflet and/or instruction manual.

Burner accessories

Extended head kit

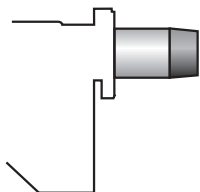

Burners standard head can be transformed into "extended head" versions by using the special kit. Here the KITS available for the various burners are listed, showing the original and the extended lengths.

BURNER	STANDARD HEAD LENGTH (mm)	EXTENDED HEAD LENGTH (mm)	KIT CODE
▶ BS1	70 ÷ 116	150 ÷ 160	20031875
▶ BS2 (long)	100 ÷ 114	170 ÷ 180	3001007
▶ BS2 (extra long)	100 ÷ 114	270 ÷ 280	3001008
▶ BS3	110 ÷ 128	267 ÷ 282	3001009
▶ BS4	145 ÷ 168	302 ÷ 317	3001016

Alternative combustion head kit

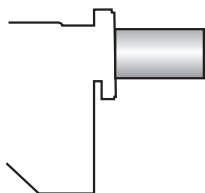

This kit can be used to prevent combustion instability which could arise with particular heat generators.

To extend the adaptability of Gulliver BS burners to any sort of application, alternative combustion heads have been developed.

These heads cause a very limited increase in NOx emissions, due to the slower air flow.

BURNER	KIT CODE (*)
▶ BS1	3001059
▶ BS2	3001064
▶ BS3	3001060
▶ BS4	3001070

(*) CE approval on field is required

LPG kit



For burning LPG gas, a special kit is available to be fitted to the combustion head on the burner, as shown in the following table.

BURNER	KIT CODE FOR STANDARD HEAD	KIT CODE (*)	KIT CODE FOR EXTENDED HEAD
▶ BS1	3001003	3002734	3001003
▶ BS2	3001004	3002735	3001004
▶ BS3	3001005	3002736	3001005
▶ BS4	3001011	3002737	3001011

(*) Kit for LPG with Butane amount over 30%, without CE certification

Town Gas kit



For burning Town Gas, a special kit is available to be fitted to the combustion head on the burner, as shown in the following table.

BURNER	KIT CODE FOR STANDARD HEAD (*)	KIT CODE FOR EXTENDED HEAD (*)
▶ BS1	3002727	-
▶ BS2	3002728	3002728
▶ BS3	3002729	3002729

(*) Without CE certification

Low NOx One Stage Gas Burners

GULLIVER BS SERIES

Burner accessories

Ground fault interrupter kit



A "Ground fault interrupter kit" is available as a safety device in case of electrical system fault. It is supplied with burners with pin plug.

BURNER	KIT CODE
► BS1 - BS2 - BS3 - BS4	3001180

Multibloc rotation kit

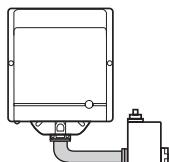

There is a special kit available that can be used to install the burner turned 180°. This kit is designed to ensure the gas train valve properly.

BURNER	KIT CODE
► BS1	3001179
► BS2	3001177
► BS3 - BS4	3001178

7-pin plug kit

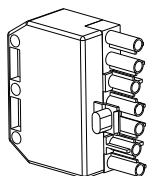

If necessary a 7-pin plug kit is available (in packaging of n. 5 pieces).

BURNER	KIT CODE
► BS1 - BS2 - BS3 - BS4	3000945

Gas train accessories

Seal control kit



To test the valve seals on the gas train, (except for the model with Multibloc MBC 65 DLE) a special "seal control kit" is available.

GAS TRAIN	KIT CODE for 50 Hz operation	KIT CODE for 60 Hz operation
► MB/1 type	3010123	20168805

GULLIVER BSD SERIES

The Riello Gulliver BSD series of two stage gas burners, is a complete range of Low NOx emission products, developed to respond to any request for home heating, conforming to the most severe standards regarding the reduction of polluting emissions.

This series of burners is available in four different models with an output ranging from 16 to 250 kW, divided in four different structures.

All the models use the same components designed by Riello for the Gulliver series. The high quality level guarantees safe working. The burners are fitted with a microprocessor-based burner safety control box which supplies indication of operation and diagnosis of fault cause.

In developing these burners, special attention was paid to reducing noise, the ease of installation and adjustment, to obtaining the smallest size possible to fit into any sort of boiler available on the market.

Two stage working guarantees high level performance from the thermal unit.

All the models are approved by the EN 676 European Standard and conform to European Directives, Gas Appliance, EMC, Low Voltage, Boiler Efficiency.

All the Gulliver BSD burners are tested before leaving the factory.

Guidelines for installation of burners in conformity to EU Regulation:

A RIELLO burner (Heat Generator), where it is matched with a water-based boiler (Heater Housing) with a nominal output ≤ 400 kW, providing heat for heating purposes and heat to deliver sanitary hot water, can be installed:

- With boilers (heater housings) already in service in the field, for replacement of identical products, in conformity to Article 1, paragraph 2, point (G) of the EU Regulation No. 813/2013;
- With boilers (heater housings) on a new installation.



BS1D	16/19	÷	52	kW
BS2D	35/40	÷	92	kW
BS3D	65/80	÷	197	kW
BS4D	110/140	÷	249	kW

FIRING RATES

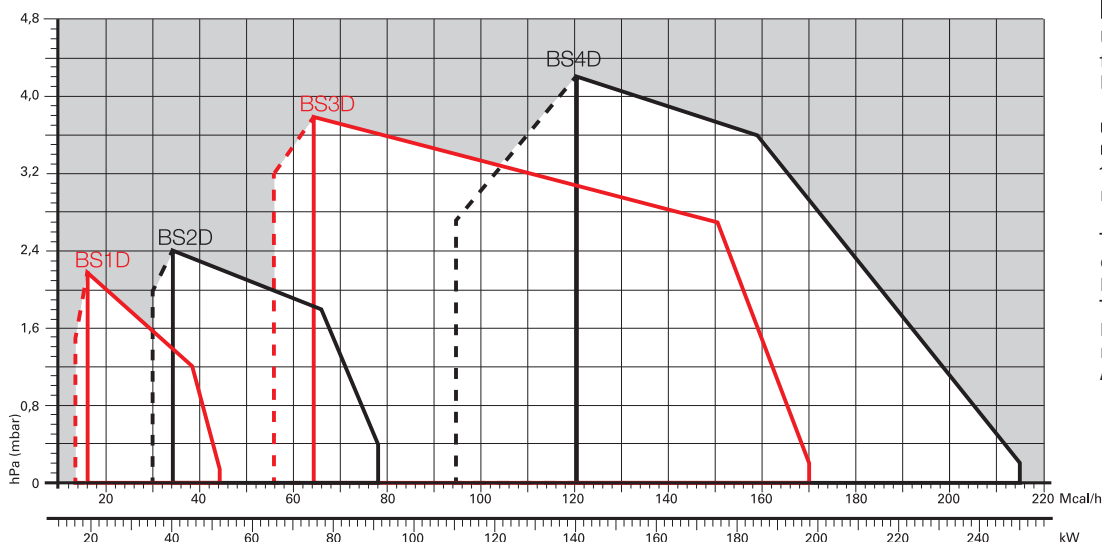

Useful working field for choosing the burner



1st stage operation range

Test conditions conforming to EN676
 Temperature: 20°C
 Pressure: 1013,5 mbar
 Altitude: 0 m a.s.l.

Low NOx Two Stage Gas Burners

GULLIVER BSD SERIES

Overall dimensions (mm)

BURNER

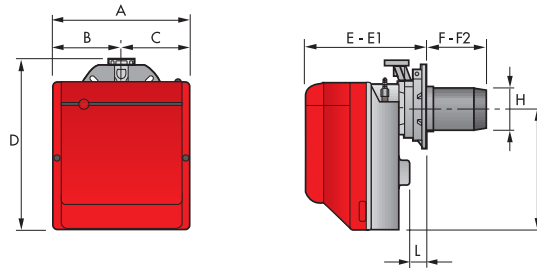

MODEL	A	B	C	D	E	E1	F - F(1)	F2 - F2(1)	H	I	L
▶ BS1D	234	122	112	295	230	276	116	70	89	210	41
▶ BS2D	255	125,5	125,5	325	238	252	114 - 270	100 - 280	106	230	45
▶ BS3D	300	150	150	391	262	280	128 - 267	110 - 282	129	285	45
▶ BS4D	300	150	150	392	278	301	168 - 302	145 - 317	137	286	45

(1) Dimension with extended head

BURNER - BOILER MOUNTING FLANGE

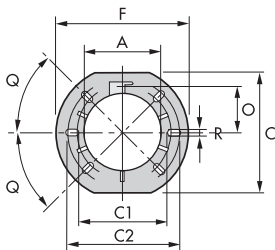

MODEL	A	C	C1	C2	F	O	Q	R
▶ BS1D	89	167	140	170	192	66	45°	1
▶ BS2D	106	167	140	170	192	66	45°	1
▶ BS3D	129	201	160	190	216	76,5	45°	1
▶ BS4D	137	203	170	200	218	80,5	45°	1

PACKAGING

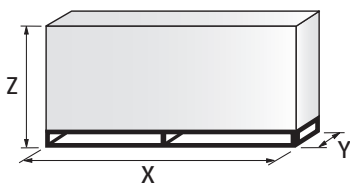

MODEL	X - X(1)	Y - Y(1)	Z - Z(1)	kg - kg(1)
▶ BS1D	395	278	350	11
▶ BS2D	405 - 593	298 - 300	375 - 380	12 - 14
▶ BS3D	450 - 713	345	440 - 445	16 - 18
▶ BS4D	510 - 713	345	440 - 445	18 - 20

(1) Dimension with extended head

GULLIVER BSD SERIES

Specification

DESIGNATION OF SERIES

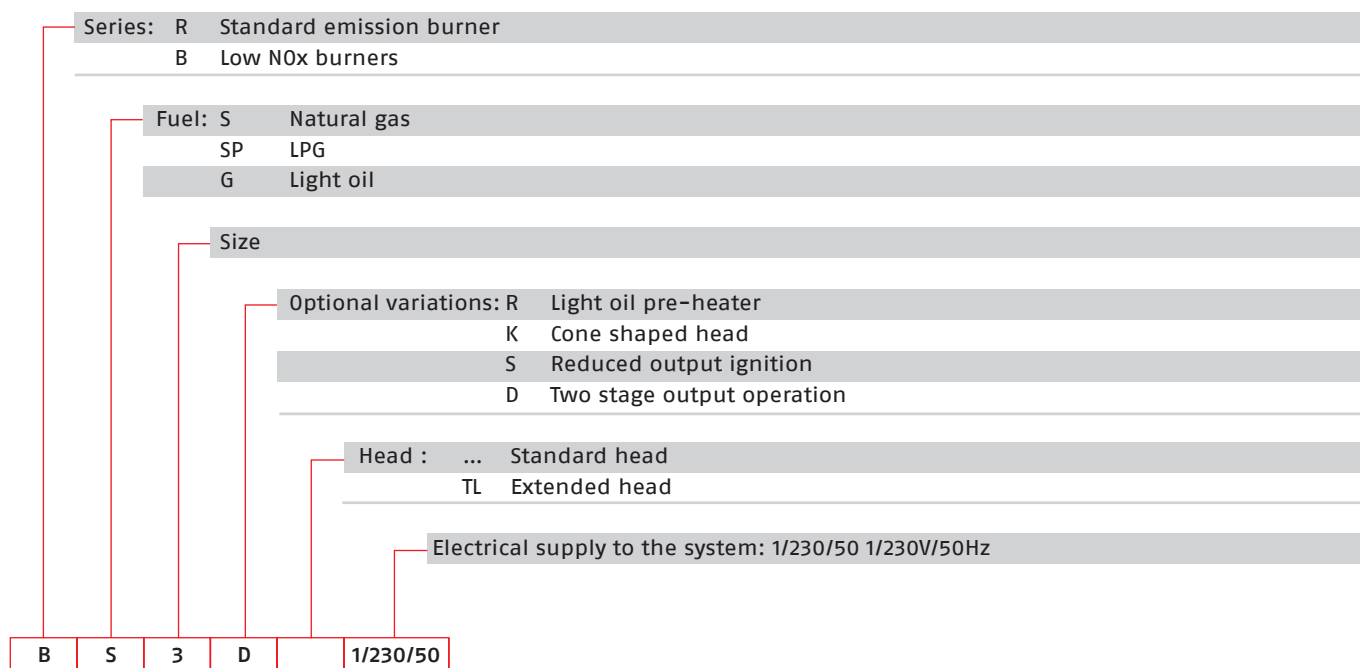

STATE OF SUPPLY

Monoblock, gas burners, completely automatic, two stage operation, made up of:

- Fan with forward curve blades
- Cover lined with sound-proofing material
- Air damper, completely closed in stand by, driven by an electric servomotor
- Air damper with 1st and 2nd stage adjustment (2nd stage external adjustment, with no need to remove the cover)
- Single phase electric motor 230 V, 50 Hz
- Combustion head fitted with:
 - stainless steel head cone, resistant to high temperatures
 - ignition electrodes
 - ionisation probe
 - gas distributor
 - flame stability disk
- Flame inspection window
- Adjustable air pressure switch, with graduated selector, to guarantee burner lock out in the case of insufficient combustible air
- Microprocessor-based burner safety control box, with diagnostic and remote reset functions
- Protection filter against radio interference (included into burner safety control box)
- IP X0D (IP 40) electric protection level.

Standard equipment:

- Sliding flange
- Flange insulation screen
- Screws and nuts for fixing the flange to the boiler
- 7-pin plug
- 4-pin plug
- Remote control release kit
- Instruction handbook for installation, use and maintenance
- Spare parts catalogue.

Low NOx Two Stage Gas Burners

GULLIVER BSD SERIES

Available models

Burners

CODE	MODEL	HEAT OUTPUT		TOTAL ELECTRICAL POWER (kW)	CERTIFICATION	NOTE
		(kW)	NATURAL GAS (Nm ³ /h)			
3761558	BS1D	1/230/50	16/19 - 52	1,6/1,9 - 5,2	0,150	CE - 0085 AQ0409 (1)
3761658	BS2D	1/230/50	35/40 - 92	3,5/4 - 9	0,180	CE - 0085 AQ0409 (1)
3761618	BS2D TL	1/230/50	35/40 - 92	3,5/4 - 9	0,180	CE - 0085 AQ0409 (1)
3761758	BS3D	1/230/50	65/80 - 197	6,5/8 - 20	0,350	CE - 0085 AQ0409 (1)
3761718	BS3D TL	1/230/50	65/80 - 197	6,5/8 - 20	0,350	CE - 0085 AQ0409 (1)
3761858	BS4D	1/230/50	110/140 - 249	11/14 - 25	0,530	CE - 0085 AQ0409 (1)
3761818	BS4D TL	1/230/50	110/140 - 249	11/14 - 25	0,530	CE - 0085 AQ0409 (1)

Net calorific value G20: 10 kWh/Nm³ - Density: 0,71 kg/Nm³.

Net calorific value LPG: 25,8 kWh/Nm³ - Density: 2,02 kg/Nm³.

The burners of BS series are in according to 2016/426/EU - 2014/30/EU - 2014/35/EU - 2006/42 EC Directive and EN 676.

(1) With plug and socket.

Gas Trains

GAS TRAIN CODE *	GAS TRAIN MODEL	NATURAL GAS		LPG		NOTE
		BURNER (type)	ADAPTER (code)	BURNER (type)	ADAPTER (code)	
MULTIBLOC	3970539	MB 405/2 - F1SD 20	BS1D		BS1D	(1)
	3970540	MB 405/2 - F2SD 20	BS2D		BS2D	(1)
	3970538	MB 407/2 - F2SD 20	BS2D		BS2D	(1)
	3970541	MB 407/2 - F3SD 20	BS3D - BS4D		BS3D - BS4D	(1)
	3970542	MB 410/2 - F3SD 20	BS3D - BS4D		BS3D - BS4D	
	3970543	MB 412/2 - F3SD 20	BS3D - BS4D		BS3D - BS4D	

Please see Designation of Gas Train Series in the page before the Catalogue index.

* Gas trains are 230V/50Hz - 220V/60Hz electrical supply.

(1) With installed plug.

The valve seal control device is compulsory (conforming to EN 676) on gas trains to burners with a maximum output over 1200 kW.

To select the gas train please refer to the technical data leaflet and/or instruction manual.

Burner accessories

Extended head kit

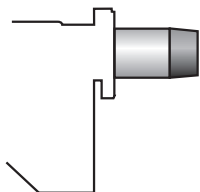

Burners standard head can be transformed into "extended head" versions by using the special kit. Here the KITS available for the various burners are listed, showing the original and the extended lengths.

BURNER	STANDARD HEAD LENGTH (mm)	EXTENDED HEAD LENGTH (mm)	KIT CODE
▶ BS1D	70 ÷ 116	1500 ÷ 160	20031875
▶ BS2D (long)	100 ÷ 114	170 ÷ 180	3001007
▶ BS2D (extra long)	100 ÷ 114	270 ÷ 280	3001008
▶ BS3D	110 ÷ 128	267 ÷ 282	3001009
▶ BS4D	145 ÷ 168	302 ÷ 317	3001016

Alternative combustion head kit

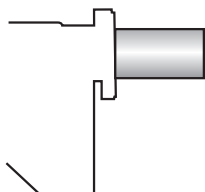

This kit can be used to prevent combustion instability which could arise with particular heat generators.

To extend the adaptability of Gulliver BSD burners to any sort of application, alternative combustion heads have been developed.

These heads cause a very limited increase in NOx emissions, due to the slower air flow.

BURNER	KIT CODE (*)
▶ BS1D	3001059
▶ BS2D	3001064
▶ BS3D	3001060
▶ BS4D	3001070

(*) CE approval on field is required

LPG kit



For burning LPG gas, a special kit is available to be fitted to the combustion head on the burner, as shown in the following table.

BURNER	KIT CODE FOR STANDARD HEAD	KIT CODE (*)	KIT CODE FOR EXTENDED HEAD
▶ BS1D	3001003	3002734	3001003
▶ BS2D	3001004	3002735	3001004
▶ BS3D	3001005	3002736	3001005
▶ BS4D	3001011	3002737	3001011

(*) Kit for LPG with Butane amount over 30%, without CE certification

Town Gas kit



For burning Town Gas, a special kit is available to be fitted to the combustion head on the burner, as shown in the following table.

BURNER	KIT CODE FOR STANDARD HEAD (*)	KIT CODE FOR EXTENDED HEAD (*)
▶ BS1D	3002727	-
▶ BS2D	3002728	3002728
▶ BS3D	3002729	3002729

(*) Without CE certification

Low NOx Two Stage Gas Burners

GULLIVER BSD SERIES

Burner accessories

Ground fault interrupter kit



A "Ground fault interrupter kit" is available as a safety device in case of electrical system fault. It is supplied with burners with pin plug.

BURNER	KIT CODE
► BS1D – BS2D – BS3D – BS4D	3001180

Multibloc rotation kit

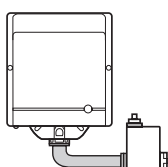

There is a special kit available that can be used to install the burner turned 180°. This kit is designed to ensure the gas train valve properly.

BURNER	KIT CODE
► BS1D	3001179
► BS2D	3001177
► BS3D – BS4D	3001178

7-pin plug kit

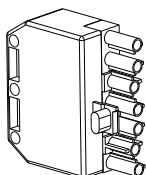

If necessary a 7-pin plug kit is available (in packaging of n. 5 pieces).

BURNER	KIT CODE
► BS1D – BS2D – BS3D – BS4D	3000945

Gas train accessories

Seal control kit



To test the valve seals on the gas train a special "seal control kit" is available.

GAS TRAIN	KIT CODE for 50 Hz operation	KIT CODE for 60 Hz operation
► MB/2 type	3010123	20168805

GULLIVER BS/M SERIES

The Riello Gulliver BS/M series of two stage, progressive or modulating gas burners, is a complete range of Low NOx emission products, developed to respond to any request for home heating, conforming to the most severe standards regarding the reduction of polluting emissions.

This series of burners is available in three different models with an output ranging from 49 to 250 kW, divided in three different structures.

All the models use the same components designed by Riello for the Gulliver series. The high quality level guarantees safe working.

In developing these burners, special attention was paid to reducing noise, the ease of installation and adjustment, to obtaining the smallest size possible to fit into any sort of boiler available on the market.

Two stage operation guarantees high level performance from the thermal unit. All the models are approved by the EN 676 European Standard, conform to European Directives, Gas Appliance, EMC, Low Voltage, Boiler Efficiency.

All the Gulliver BS/M burners are tested before leaving the factory.

Guidelines for installation of burners in conformity to EU Regulation:

A RIELLO burner (Heat Generator), where it is matched with a water-based boiler (Heater Housing) with a nominal output ≤ 400 kW, providing heat for heating purposes and heat to deliver sanitary hot water, can be installed:

- With boilers (heater housings) already in service in the field, for replacement of identical products, in conformity to Article 1, paragraph 2, point (G) of the EU Regulation No. 813/2013;
- With boilers (heater housings) on a new installation.

FIRING RATES

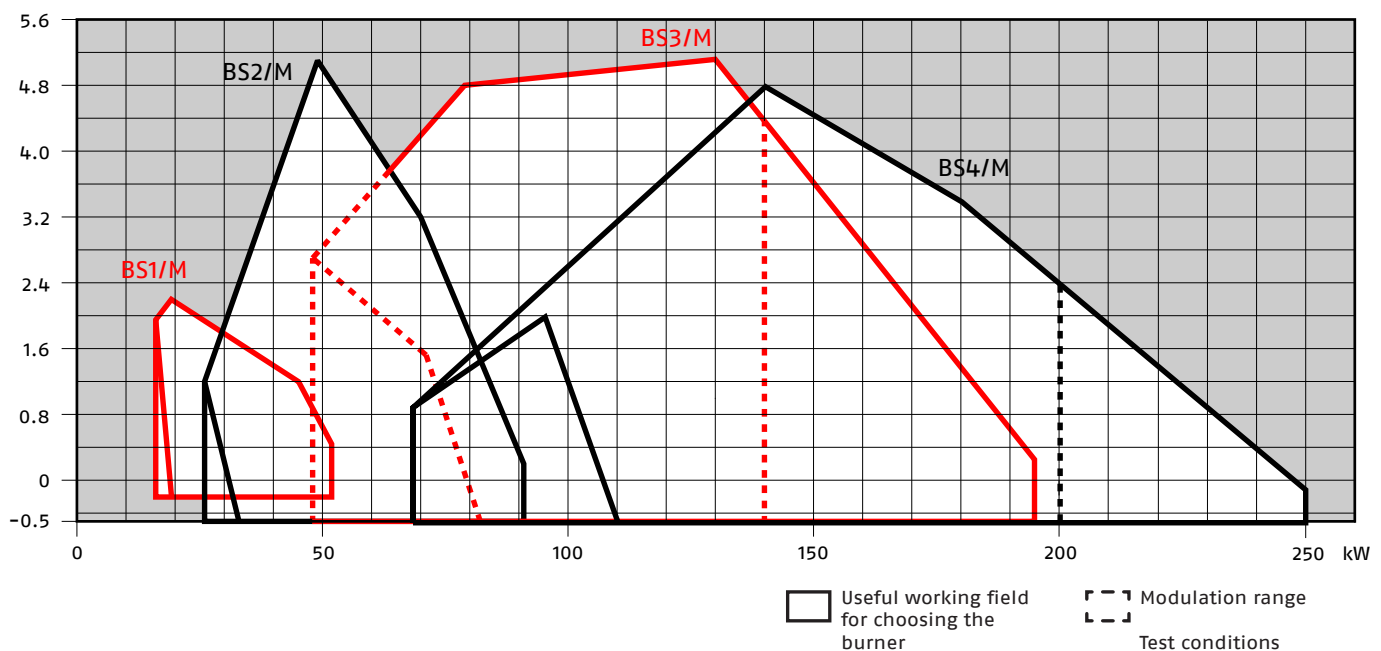

BS1/M	16/19 ÷	52 kW
BS2/M	26/49 ÷	91 kW
BS3/M	48/79 ÷	195 kW
BS4/M	68/140 ÷	250 kW



Test conditions
conforming to EN676
Temperature: 20°C
Pressure: 1013,5 mbar
Altitude: 0 m a.s.l.

Low NOx Two Stage Progressive and Modulating Gas Burners

GULLIVER BS/M SERIES

Overall dimensions (mm)

BURNER

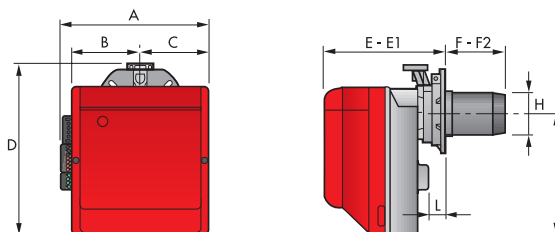

MODEL	A	B	C	D	E	E1	F	F2	H	I	L
▶ BS1/M	285	125,5	125,5	316	234,5	-	116,5	-	89,5	230	8
▶ BS2/M	285	125,5	125,5	325	238	252	114	100	106	230	18
▶ BS2/M TL	285	125,5	125,5	325	238	252	184	170	106	230	18
▶ BS3/M	330	150	150	391	262	280	128	110	129	285	21
▶ BS3/M TL	330	150	150	391	262	270	285	267	129	285	21
▶ BS4/M	330	150	150	392	278	301	168	145	137	286	21
▶ BS4/M TL	330	150	150	392	278	301	325	302	137	286	21

BURNER - BOILER MOUNTING FLANGE

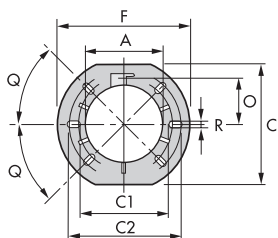

MODEL	A	C	C1	C2	F	O	Q	R
▶ BS1/M	89,5	167	140	170	192	66	45°	11
▶ BS2/M	106	167	140	170	192	66	45°	11
▶ BS2/M TL	106	167	140	170	192	66	45°	11
▶ BS3/M	129	201	160	190	216	76,5	45°	11
▶ BS3/M TL	129	201	160	190	216	76,5	45°	11
▶ BS4/M	137	203	170	200	218	80,5	45°	11
▶ BS4/M TL	137	203	170	200	218	80,5	45°	11

PACKAGING

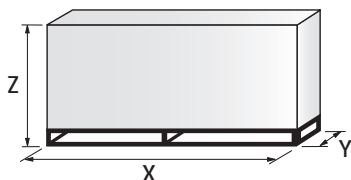

MODEL	X	Y	Z	kg
▶ BS1/M	405	328	375	12
▶ BS2/M	405	328	375	12
▶ BS2/M TL	583	318	365	14
▶ BS3/M	450	375	440	16
▶ BS3/M TL	510	375	440	18
▶ BS4/M	510	375	440	18
▶ BS4/M TL	610	383	367	20

Specification

DESIGNATION OF SERIES

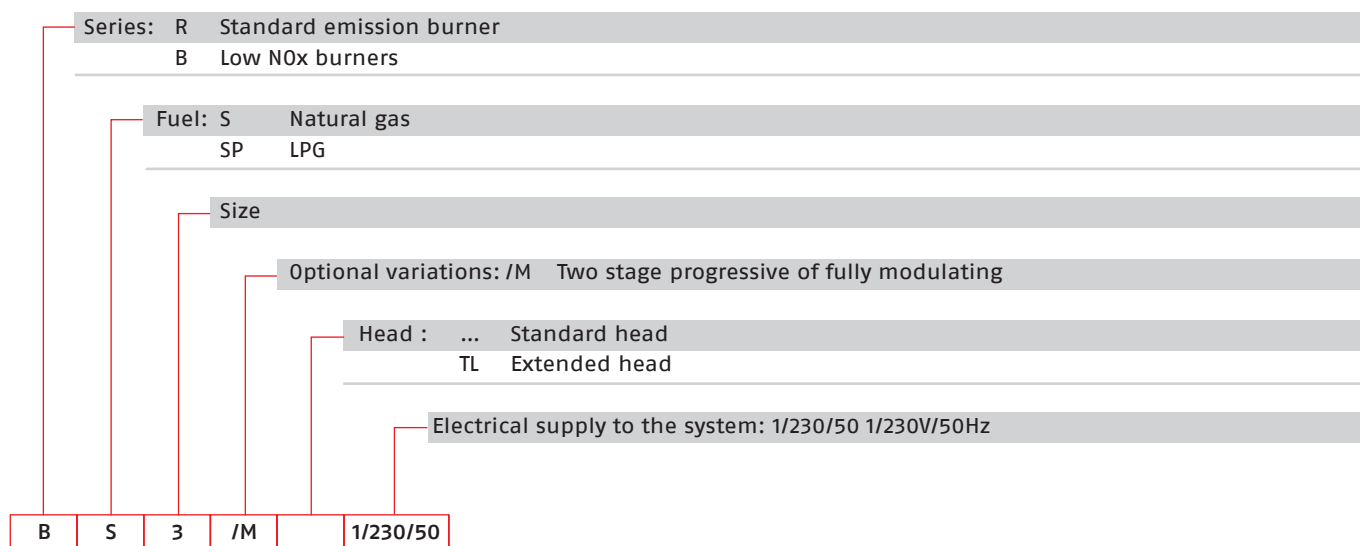

STATE OF SUPPLY

Monobloc, gas burners, completely automatic, high/low progressive operation mode or fully modulating by using a regulator:

- Fan with forward curve blades
- Cover lined with sound proofing material
- Microprocessor-based burner safety control box, with diagnostic and remote reset functions
- Servomotor to drive the air damper to fully closed position at stand by, low and high fire position
- Single phase electric motor 230 V, 50 Hz
- Combustion head fitted with:
 - stainless steel head cone, resistant to high temperatures
 - ignition electrodes
 - ionisation probe
 - gas distributor
 - flame stability disk
- Flame inspection window
- Adjustable air pressure switch, with graduated selector, to guarantee burner lock out in the case of insufficient combustible air
- Protection filter against radio interference
- IP X0D (IP 40) electric protection level.

Standard equipment:

- Flange with insulating gasket
- Screws and nuts for flange to be fixed to boiler
- Screw and nut for flange
- Blue plastic tube
- G 1/8 union elbow
- 4-pin plug
- 7-pin plug
- Instruction handbook for installation, use and maintenance
- Spare parts catalogue.

Low NOx Two Stage Progressive and Modulating Gas Burners

GULLIVER BS/M SERIES

Available models

Burners

CODE	MODEL	HEAT OUTPUT		TOTAL ELECTRICAL POWER (kW)	CERTIFICATION	NOTE
		(kW)	NATURAL GAS (Nm ³ /h)			
20096670	BS1/M 1/230/50	16/19 - 52	1,6/1,9 - 5,2	0,140	CE - 0085 BN0609	(1)
3762250	BS2/M 1/230/50	26/49 - 91	2,6/4,9 - 9,1	0,180	CE - 0085 BN0609	(1)
20052610	BS2/M TL 1/230/50	26/49 - 91	2,6/4,9 - 9,1	0,180	CE - 0085 BN0609	(1)(2)
3762350	BS3/M 1/230/50	48/79 - 195	4,8/7,9 - 19,5	0,350	CE - 0085 BN0609	(1)
3762370	BS3/M TL 1/230/50	48/79 - 195	4,8/7,9 - 19,5	0,350	CE - 0085 BN0609	(1)(2)
3762450	BS4/M 1/230/50	68/140 - 250	6,8/14 - 25	0,530	CE - 0085 BN0609	(1)
20052613	BS4/M TL 1/230/50	68/140 - 250	6,8/14 - 25	0,530	CE - 0085 BN0609	(1)(2)

Net calorific value G20: 10 kWh/Nm³ - Density: 0,71 kg/Nm³.

The burners of BS/M series are in according to 2016/426/EU - 2014/30/EU - 2014/35/EU - 2006/42 EC Directive and EN 676.

(1) With plug and socket.

(2) Head Length: see quote F-F2 in the Overall Dimensions table.

Gas Trains

	GAS TRAIN CODE *	GAS TRAIN MODEL	NATURAL GAS		LPG		NOTE
			BURNER (type)	ADAPTER (code)	BURNER (type)	ADAPTER (code)	
MULTIBLOC	20105417	CG 120/P - F52D 00	BS1/M		BS1/M		(1)(2)
	3970587	CG 120/P - F2SD 00	BS2/M		BS2/M		(1)(2)
	3970588	CG 220/P - F3SD 00	BS3/M - BS4/M		BS3/M - BS4/M		(1)(2)

Please see Designation of Gas Train Series in the page before the Catalogue index.

* Gas trains are 230V/50Hz - 220V/60Hz electrical supply.

(1) With installed plug.

(2) Gas maximum inlet pressure 100 mbar.

The valve seal control device is compulsory (conforming to EN 676) on gas trains to burners with a maximum output over 1200 kW.

To select the gas train please refer to the technical data leaflet and/or instruction manual.

GULLIVER BS/M SERIES

Burner accessories

Extended head kit

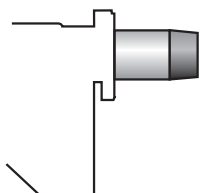

Burners standard head can be transformed into "extended head" versions by using the special kit.

Here the KITS available for the various burners are listed, showing the original and the extended lengths.

BURNER	STANDARD HEAD LENGTH (mm)	EXTENDED HEAD LENGTH (mm)	KIT CODE
▶ BS1/M (long)	70 ÷ 116	114 ÷ 160	20097850
▶ BS2/M (long)	100 ÷ 114	170 ÷ 180	3002722
▶ BS2/M (extra long)	100 ÷ 114	270 ÷ 280	3002723
▶ BS3/M	110 ÷ 128	267 ÷ 282	3002724
▶ BS4/M	145 ÷ 168	302 ÷ 317	3002725

LPG kit



For burning LPG gas, a special kit is available to be fitted to the combustion head on the burner, as shown in this table.

BURNER	KIT CODE FOR STANDARD HEAD	KIT CODE FOR EXTENDED HEAD
▶ BS1/M	3001003	3001003
▶ BS2/M	3002711	3002711
▶ BS3/M	3002712	3002712
▶ BS4/M	3001011	3001011

Alternative combustion head kit

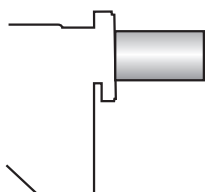

To extend the adaptability of Gulliver BS/M burners to any sort of application, alternative combustion heads have been developed, for example, to overcome situations of combustion instability which could arise with certain heat generators.

These heads cause a very limited increase in NOx emissions, due to the slower air flow.

BURNER	KIT CODE (*)
▶ BS1/M	3001059
▶ BS2/M	3001064
▶ BS3/M	3001060
▶ BS4/M	3001070

(*) CE approval on field is required

Ground fault interrupter kit



A "Ground fault interrupter kit" is available as a safety device in case of electrical system fault.

BURNER	KIT CODE
▶ BS1/M - BS2/M - BS3/M - BS4/M	3001180

7-pin plug kit

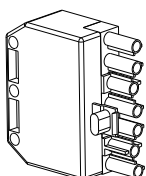

If necessary a 7-pin plug kit is available (in packaging of n. 5 pieces).

BURNER	KIT CODE
▶ BS1/M - BS2/M - BS3/M - BS4/M	3000945

Low NOx Two Stage Progressive and Modulating Gas Burners

GULLIVER BS/M SERIES

Burner accessories

Accessories for modulating operation



To obtain modulating operation, the BS/M series of burners requires a regulator with three point outlet controls. The following table lists the accessories for modulating operation with their application range. For remote setpoint use RWF 55.

BURNER	REGULATOR TYPE	REGULATOR CODE
▶ BS1/M - BS2/M - BS3/M - BS4/M	RWF 50.2	20102002
	RWF 55.5	20101966

The relative temperature or pressure probes fitted to the regulator, must be chosen on the basis of the application.



BURNER	PROBE TYPE	RANGE (°C) (bar)	PROBE CODE
▶ BS1/M - BS2/M BS3/M - BS4/M	Temperature PT 100	-100 ÷ 500°C	3010110
	Pressure 4 ÷ 20 mA	0 ÷ 2,5 bar	3010213
	Pressure 4 ÷ 20 mA	0 ÷ 16 bar	3010214

Depending on the servomotor fitted to the burner, a three-pole potentiometer (1000 Ω) can be installed to check the position of the servomotor.

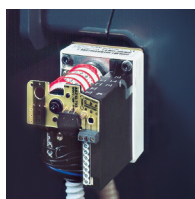

BURNER	CODE
▶ BS1/M - BS2/M - BS3/M - BS4/M	3010109

Modulating operation can also be obtained with an analog control signal converter and a feedback three-pole potentiometer. Alternatively, the potentiometer can be used to check the servomotor position.



BURNER	TYPE (INPUT SIGNAL)	CODE
▶ BS1/M - BS2/M BS3/M - BS4/M	0/2 - 10 V (impedance 200 KΩ)	3091380
	0/4 - 20 mA (impedance 250 Ω)	

PC interface kit



To connect the RMG control box to a personal computer for the transmission of operation, fault signals and detailed service information, an interface adapter with PC software are available.

BURNER	CODE
▶ BS1/M - BS2/M - BS3/M - BS4/M	3002719

Gas train accessories

Seal control kit



To test the valve seals on the gas train, a special "seal control kit" is available.

GAS TRAIN	CODE
▶ CG/P type	20021563

RS 25÷45 C05 SERIES

The new RS C05 series represents Riello's ultimate step of innovation in terms of Low NOx technology applied to gas fueled burners in the low-medium power segment.

The series includes three models, working in Two Stage operation, with an output ranging from 45 to 570 kW.

The combustion head has been re-designed in order to achieve very low values of NOx emissions (< 56 mg/kWh), for use in low or medium temperature hot water boilers, hot air or steam boilers, diathermic oil boilers.

RS C05 burners series guarantees high efficiency levels in all the various applications, thus reducing fuel consumption and running costs. The exclusive design ensures reduced dimensions, simple use and maintenance. Optimisation of sound emissions is guaranteed by the special design of the air suction circuit and by incorporated sound proofing material.

A wide range of accessories guarantees elevated working flexibility.



Guidelines for installation of burners in conformity to EU Regulation:

A RIELLO burner (Heat Generator), where it is matched with a water-based boiler (Heater Housing) with a nominal output ≤ 400 kW, providing heat for heating purposes and heat to deliver sanitary hot water, can be installed:

- With boilers (heater housings) already in service in the field, for replacement of identical products, in conformity to Article 1, paragraph 2, point (G) of the EU Regulation No. 813/2013;
- With boilers (heater housings) on a new installation.

RS 25 C05	70/125 ÷	340 kW
RS 35 C05	82/200 ÷	440 kW
RS 45 C05	90/190 ÷	570 kW

FIRING RATES

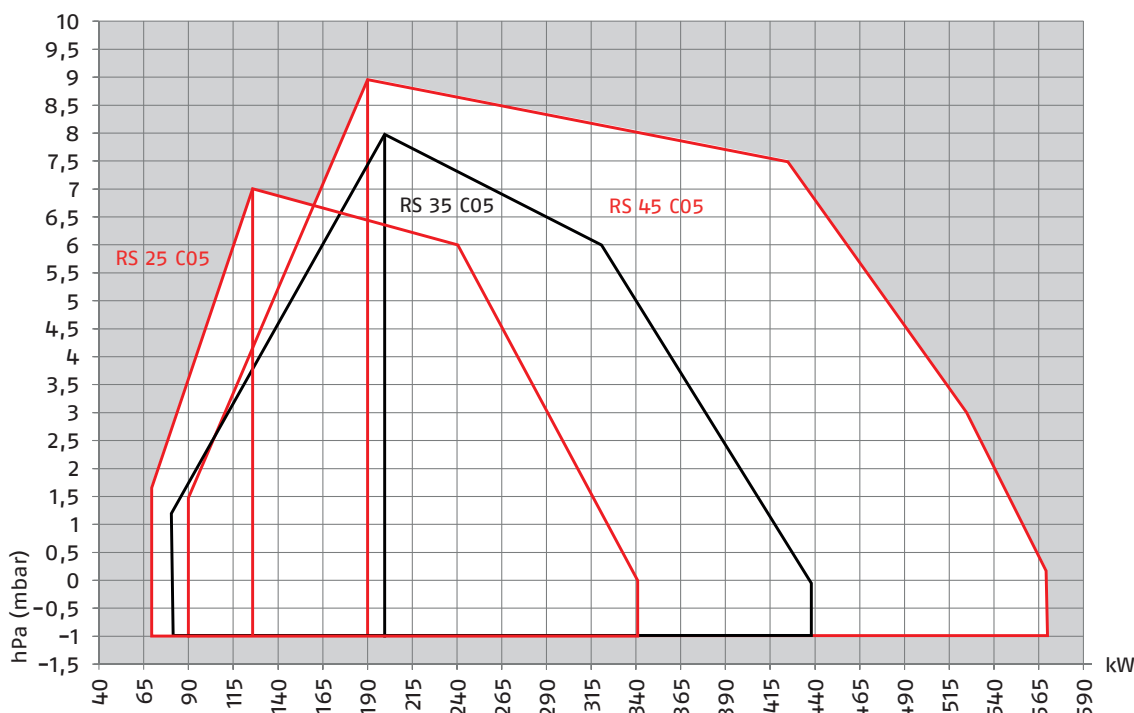

Useful working field for choosing the burner



Modulation range

Test conditions conforming to EN676
 Temperature: 20°C
 Pressure: 1013,5 mbar
 Altitude: 0 m a.s.l.

Low NOx Two Stage Modulating Gas Burners

RS 25÷45 C05 SERIES

Overall dimensions (mm)

BURNER

RS 25 - 35 C05

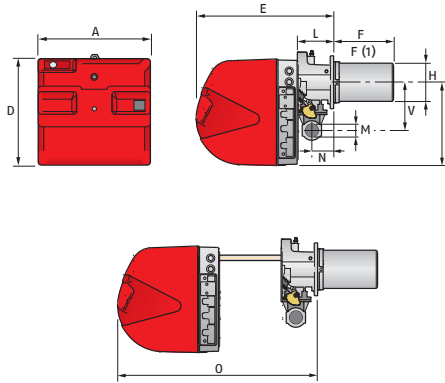

RS 45 C05

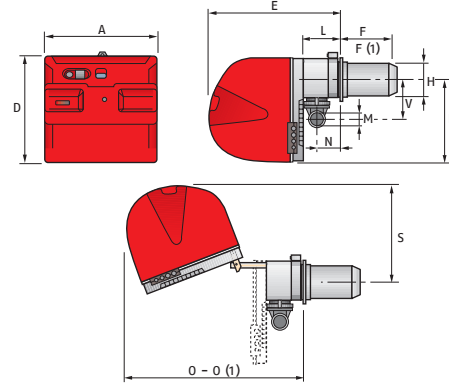

MODEL	A	B	C	D	E	F - F (1)	G* - G(1)*	H	I	L	M	N	O - O(1)	S	V
▶ RS 25 C05	442	-	-	422	508	230 - 365	- -	140	305	138	1"1/2	84	780 - -	-	177
▶ RS 35 C05	442	-	-	422	508	192 - 327	- -	152	305	138	1"1/2	84	780 - -	-	177
▶ RS 45 C05	476	-	-	474	580	192 - 327	- -	160	352	164	1"1/2	108	810 - 810	367	168

(1) Length with extended combustion head. * Maximum depth of the boiler door including the depth of the burner flange insulating gasket.

BURNER - BOILER MOUNTING FLANGE

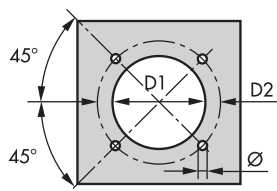

MODEL	D1	D2	Ø
▶ RS 25 C05	160	224	M8
▶ RS 35 C05	160	224	M8
▶ RS 45 C05	165	224	M8

PACKAGING

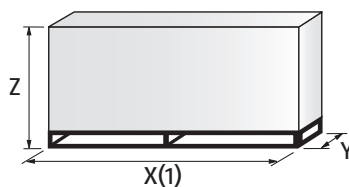

MODEL	X(1)	Y	Z	kg
▶ RS 25 C05	1000	485	500	39
▶ RS 35 C05	1000	485	500	40
▶ RS 45 C05	1015	500	630	48

(1) dimension with standard and extended head

RS 25÷45 C05 SERIES

Specification

DESIGNATION OF SERIES

Series: R

Fuel: S Natural Gas

L Light oil

LS Light oil/Natural Gas

N Heavy oil

Size:

Setting: /1 Single stage

Two stage

/M Modulating-Mechanical cam

/E Electronic cam

/P Proportioning air/gas valve

/EV Electronic cam predisposed for variable speed (with inverter)

/EVi Electronic cam with integrated inverter

Emission: ... or C01 Class 1 EN676

MZ Class 2 EN676

BLU Class 3 EN676

MX Class 3 EN676

C05 Class 5 EN676 (NOx < 56 mg/kWh)

Head length: TC standard head

TL extended head

Flame control system: FS1 Standard/Intermittent (at least 1 stop every 24 h)

FS2 Continuous (1 stop every 72 h)

Electrical supply to the system:

1/230/50 1/230V/50Hz

3/230/50 3/230V/50Hz

3/400/50 3N/400V/50Hz

3/230-400/50 3/230V/50Hz - 3N/400V/50Hz

3/220/60 3/220V/60Hz

3/380/60 3N/380V/60Hz

3/220-380/60 3/220/60Hz - 3N/380V/60Hz

Auxiliary voltage: 230/50-60 230V/50-60H

110/50-60 110V/50-60Hz

R S 35 C05 TC FS1 3/230-400/50 230/50-60

BASIC DESIGNATION

EXTENDED DESIGNATION

Low NOx Two Stage Modulating Gas Burners

RS 25÷45 C05 SERIES

Specification

STATE OF SUPPLY

Monoblock forced draught Low Nox gas burner, with two stage operation, fully automatic, made up of:

Air suction circuit with sound proofing material

High performance fan

- Air damper for air flow setting and butterfly valve for regulating fuel output on 1st and 2nd stage controlled by a servomotor with variable cam
- Newly designed combustion head, for Low Nox emissions ($< 56 \text{ mg/kWh}$), fitted with:
 - stainless steel end cone, resistant to corrosion and high temperatures
 - ignition electrodes
 - ionisation probe
 - gas distributor
 - flame stability disk
- Minimum air pressure switch stops the burner in case of insufficient air quantity at the combustion head
- Burner on/off selection switch
- Microprocessor-based burner safety control box, with diagnostic functions
- Flame inspection window
- Slide bars for easier installation and maintenance
- Protection filter against radio interference
- 1st - 2nd stage manual switch
- Exclusive patented HCS (Housing Cooling System) with high thermal insulation and air circulation with continuous air volume refresh for an active cooling system and avoid heat transfer to the electrical component housing
- Plug and socket for electrical connections accessible from the external of the cover
- IP40 electric protection level.

Standard equipment

- 1 gas train flange
- 1 flange gasket
- 4 screws for fixing the flange
- 1 thermal screen
- 4 screws for fixing the burner flange to the boiler
- 3 plugs for electrical connection
- Instruction handbook for installation, use and maintenance
- Spare parts catalogue.

Available models

Burners

CODE	MODEL	HEAT OUTPUT		TOTAL ELECTRICAL POWER (kW)	CERTIFICATION	NOTE
		NATURAL GAS (kW)	(Nm ³ /h)			
20159225	RS 25 C05 TC 1/220-230/50-60 220-230/50-60	70/125÷340	4,5/12,5÷34	0,6	CE-0123CT1607	(1)
20159226	RS 25 C05 TL 1/220-230/50-60 220-230/50-60	70/125÷340	4,5/12,5÷34	0,6	CE-0123CT1607	(1)
20159227	RS 35 C05 TC 1/220-230/50-60 220-230/50-60	82/200÷440	7/20÷44	0,7	CE-0123CT1607	(1)
20159229	RS 35 C05 TL 1/220-230/50-60 220-230/50-60	82/200÷440	7/20÷44	0,7	CE-0123CT1607	(1)
20159233	RS 45 C05 TC 3/220-230/50-60 230/50-60	90/190÷570	9/19÷57	0,76	CE-0123CT1607	(1)
20159234	RS 45 C05 TL 3/220-230/50-60 230/50-60	90/190÷570	9/19÷57	0,76	CE-0123CT1607	(1)

Natural gas, net calorific value: 10 kWh/Nm³ - Density: 0,71 kg/Nm³

The burners of RS/M BLU series are in according to 2016/426/EU - 2014/30/EU - 2014/35/EU - 2006/42 EC Directive and EN 676 - LRV 92 Norm.

(1) With plug and socket.

RS 25÷45 C05 SERIES

Available models

Gas Trains

CODE	GAS TRAIN		C.T.	VPS Code	ADAPTER CODE	
	MODEL	Ø			RS 25	RS 35 - RS 45
3970500*	MB 405/1 - RT 20	Rp 3/4"	-	3010123		
3970553*	MB 407/1 - RT 20	Rp 3/4"	-	3010123		
3970599*	MB 407/1 - RT 52	Rp 3/4"	-	3010123		3000824
3970229*	MB 407/1 - RSM 20	Rp 3/4"	-	3010123		
3970258*	MB 410/1 - RT 52	Rp 1" 1/4	-	3010123		3010124
3970554*	MB 410/1 - RT 20	Rp 3/4"	-	3010123		
3970600*	MB 410/1 - RT 52	Rp 3/4"	-	3010123		3000824
3970230*	MB 410/1 - RSM 20	Rp 3/4"	-	3010123		
3970256*	MB 412/1 - RT 52	Rp 1" 1/2	-	3010123		□
3970144*	MB 412/1 - RT 20	Rp 1" 1/2	-	3010123		□
3970197**	MB 412/1 CT RT 20	Rp 1" 1/2	◆	-		□
3970231*	MB 412/1 - RSM 20	Rp 1" 1/2	-	3010123		□
3970180*	MB 415/1 - RT 30	Rp 1" 1/2	-	3010123		□
3970198**	MB 415/1 CT RT 30	Rp 1" 1/2	◆	-		□
3970250*	MB 415/1 - RT 52	Rp 1" 1/2	-	3010123		□
3970253**	MB 415/1 CT RT 52	Rp 1" 1/2	◆	-		□
3970232*	MB 415/1 - RSM 30	Rp 1" 1/2	-	3010123		□
3970181*	MB 420/1 - RT 30	Rp 2"	-	3010123		
3970182**	MB 420/1 CT RT 30	Rp 2"	◆	-		
3970257*	MB 420/1 - RT 52	Rp 2"	-	3010123		
3970252**	MB 420/1 CT RT 52	Rp 2"	◆	-		
3970233*	MB 420/1 - RSM 30	Rp 2"	-	3010123		3000822
3970234**	MB 420/1 CT RSM 30	Rp 2"	◆	-		
3970221*	MBC 1200/1 - RSM 60	Rp 2"	-	3010123		
3970225**	MBC 1200/1 CT RSM 60	Rp 2"	◆	-		
3970222*	MBC 1900/1 - FSM 40	DN 65	-	3010123		●
3970226**	MBC 1900/1 CT FSM 40	DN 65	◆	-		●
3970223*	MBC 3100/1 - FSM 40	DN 80	-	3010123		●
3970227**	MBC 3100/1 CT FSM 40	DN 80	◆	-		●
3970224*	MBC 5000/1 - FSM 80	DN 100	-	3010123		●
3970228**	MBC 5000/1 CT FSM 80	DN 100	◆	-		●
3970145*	CB 512/1 - RSM 30	Rp 1" 1/2	-	3010123		□
20045589**	CB 512/1 CT RSM 30	Rp 1" 1/2	◆	-		□
3970146*	CB 520/1 - RSM 30	Rp 2"	-	3010123		
3970160**	CB 520/1 CT RSM 30	Rp 2"	◆	-		
20044659*	CB 525/1 - RSM 30	Rp 2"	-	3010123		3000822
20044660**	CB 525/1 CT RSM 30	Rp 2"	◆	-		
3970147*	CB 5065/1 - FSM 30	DN 65	-	3010123	●	
3970161**	CB 5065/1 CT FSM 30	DN 65	◆	-	●	3000825
3970148*	CB 5080/1 - FSM 30	DN 80	-	3010123	●	●
3970162**	CB 5080/1 CT FSM 30	DN 80	◆	-	●	●
3970149*	CB 50100/1 - FSM 30	DN 100	-	3010123	●	●
3970163**	CB 50100/1 CT FSM 30	DN 100	◆	-	●	●
20015871*	CB 50125/1 - FSM 30	DN 125	-	3010123	●	●
3970196**	CB 50125/1 CT FSM 30	DN 125	◆	-	●	●

Please see designation of Gas Train Series in the page before the Catalogue index.

* 230V/50Hz - 220V/60Hz electrical supply.

** 230V/50Hz electrical supply.

The valve seal control device is compulsory (conforming to EN 676) on gas trains to burners with a maximum output over 1200 kW.

To select the gas train please refer to the technical data leaflet and/or instruction manual.

C.T. Gas valve leak detection control device:

- gas train not equipped with leak detection control device; this device can be ordered separately - see VPS column - and installed later.

◆ gas train equipped with leak detection control device.

VPS Valve leak detection control device. Supplied separately from the gas train (please see Gas train accessories paragraph for both 50 Hz and 60 Hz codes).

● Not available.

□ Additional adapter not necessary, the gas train may be connected directly to the burner.

Low NOx Two Stage Modulating Gas Burners

RS 25÷45 C05 SERIES

Burner accessories

Spacer kit

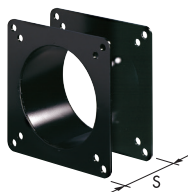

If burner head penetration into the combustion chamber needs reducing, varying thickness spacers are available, as given in the following list.

BURNER	SPACER THICKNESS S (mm)	KIT CODE
▶ RS 25 - 35 - 45 C05	110	3010095

Continuous ventilation kit



If the burner requires continuous ventilation in the stages without flame, a special kit is available as given in the following table.

BURNER	KIT CODE
▶ RS 25 - 35 C05	3010449
▶ RS 45 C05	3010094

Post-ventilation kit



To prolong ventilation after opening of thermostats chain, a special kit is available.

BURNER	POST-VENTILATION TIME (s)	KIT CODE
▶ RS 25 - 35 - 45 C05	5	3010004
	20	3010452

Connection flange kit

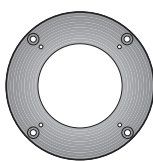

A kit is available for use where the burner opening on the boiler is of excessive diameter.

BURNER	KIT CODE
▶ RS 25 - 35 - 45 C05	3010138

Sound proofing box

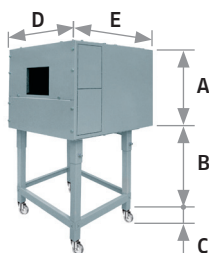

If noise emission needs reducing even further, sound-proofing boxes are available. When a lower "B" dimension is required, it is available the Box Support Kit code 20065135 which allows to reduce it at the fixed dimension of 55 mm. The sound-proofing boxes are not suitable for outdoor use.

BURNER	BOX TYPE	A (mm)	B (mm) min-max	C (mm)	D (mm)	E (mm)	[dB(A)] (*)	BOX CODE
▶ RS 25 - 35 - 45 C05	C1/3	650	372 - 980	110	690	770	10	3010403

(*) Average noise reduction according to EN 15036-1 standard

Burner accessories

Ground fault interrupter kit



A "Ground fault interrupter kit" is available as a safety device in case of electrical system fault.

BURNER	KIT CODE
▶ RS 25 - 35 C05	3010448
▶ RS 45 C05	3010321

Gas max pressure switch

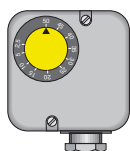

If necessary a Gas max pressure Switch kit is available and connectable to the burner electrical wiring trough Plugs & Sockets system.

BURNER	KIT CODE
▶ RS 25 - 35 C05	3010418
▶ RS 45 C05	3010493

Volt free contact kit



A volt free contact kit is available for installation onto the burner. It can be used for a remote interface between burner operating signals. Every burner can be equipped with a single kit for a remote check of the flame presence signal and the burner lock-out indication.

BURNER	KIT CODE
▶ RS 25 - 35 - 45 C05	3010419

PC Interface kit



To connect the RMG control box to a personal computer for the transmission of operation, fault signals and detailed service information, an interface adapter with PC software are available.

BURNER	KIT CODE
▶ RS 25 - 35 - 45 C05	3002719

Hours counter kit

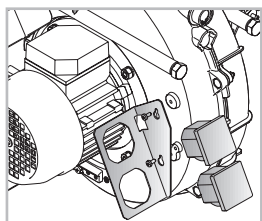

To measure the burner working time a hours counter kit is available.

BURNER	KIT CODE
▶ RS 25 - 35 C05	3010450

Protection kit (electromagnetic interferences)

When the burner is installed in a room particularly subject to electromagnetic interference (signals emitted over 10 V/m) due for example to INVERTER presence or in systems where the lengths of the thermostat connections is over 20 meters, this specific protection kit is available as an interface between the thermostatic controls and the burner.

BURNER	KIT CODE
▶ RS 25 - 35 - 45 C05	3010386

RS 25÷200/M BLU SERIES

The RS/M C05 and BLU burners series covers a firing range from 44 to 2400 kW, and it has been designed for use in low or medium temperature hot water boilers, hot air or steam boilers, diathermic oil boilers. Operation can be "two stage progressive" or, alternatively, "modulating" with the installation of a PID logic regulator and respective probes. RS/M BLU burners series guarantees high efficiency levels in all the various applications, thus reducing fuel consumption and running costs. The exclusive design ensures reduced dimensions, simple use and maintenance. Optimisation of sound emissions is guaranteed by the special design of the air suction circuit and by incorporated sound proofing material.

A wide range of accessories guarantees elevated working flexibility.

Guidelines for installation of burners in conformity to EU Regulation:

A RIELLO burner (Heat Generator), where it is matched with a water-based boiler (Heater Housing) with a nominal output ≤ 400 kW, providing heat for heating purposes and heat to deliver sanitary hot water, can be installed:

- With boilers (heater housings) already in service in the field, for replacement of identical products, in conformity to Article 1, paragraph 2, point (G) of the EU Regulation No. 813/2013;
- With boilers (heater housings) on a new installation.

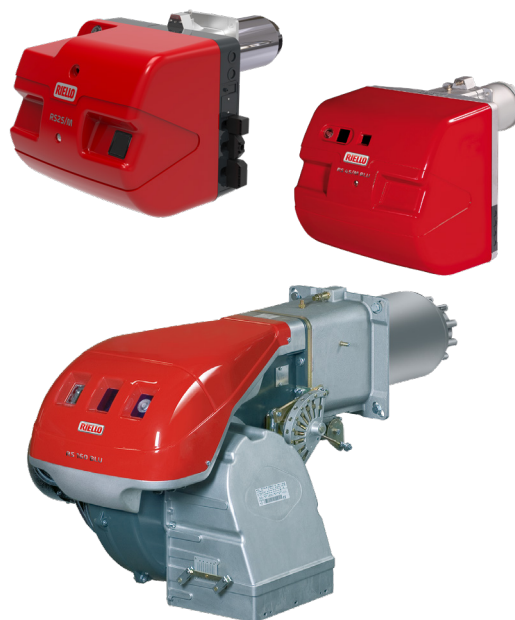

RS 25/M C05	70/125 ÷	340 kW
RS 35/M C05	82/200 ÷	440 kW
RS 45/M C05	90/190 ÷	570 kW

RS 25/M BLU	45/125 ÷	370 kW
RS 35/M BLU	72/202 ÷	480 kW
RS 55/M BLU	100/300 ÷	680 kW
RS 68/M BLU	150/350 ÷	860 kW
RS 120/M BLU	300/600 ÷	1300 kW
RS 160/M BLU	300/930 ÷	1860 kW
RS 200/M BLU	570/1375 ÷	2400 kW

FIRING RATES

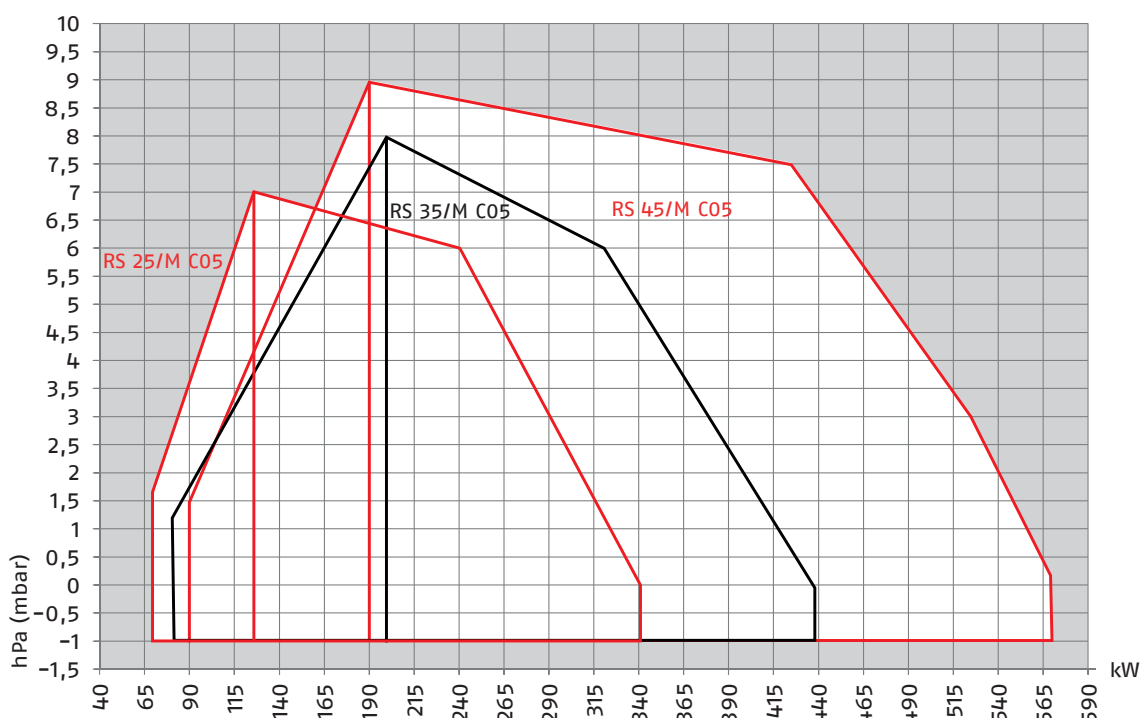

□ Useful working field for choosing the burner

▭ Modulation range

Test conditions conforming to EN676
 Temperature: 20°C
 Pressure: 1013,5 mbar
 Altitude: 0 m a.s.l.

Low NOx Modulating Gas Burners

RS 25÷200/M BLU SERIES

FIRING RATES

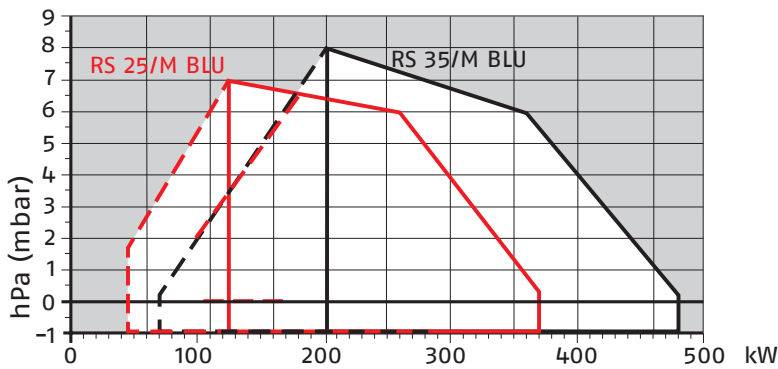

Useful working field for choosing the burner



Modulation range

Test conditions conforming to EN676
 Temperature: 20°C
 Pressure: 1013,5 mbar
 Altitude: 0 m a.s.l.

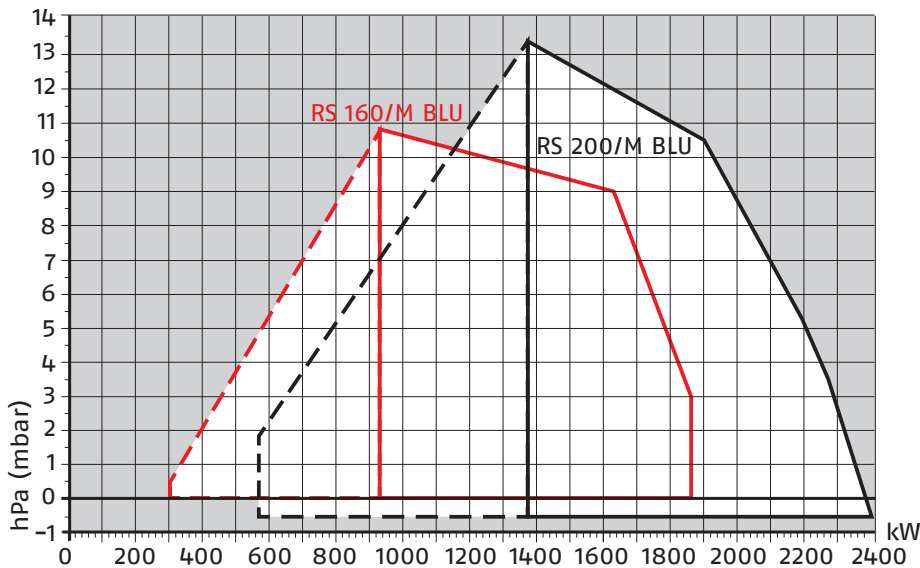
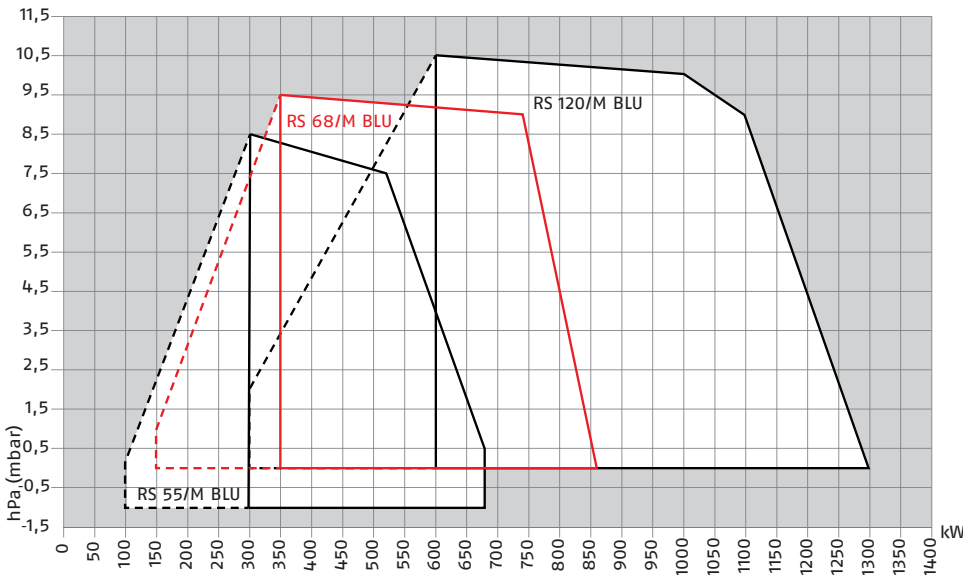

RS 25÷200/M BLU SERIES

Overall dimensions (mm)

BURNER

RS 25/M - 35/M C05 - RS 25/M - 35/M BLU

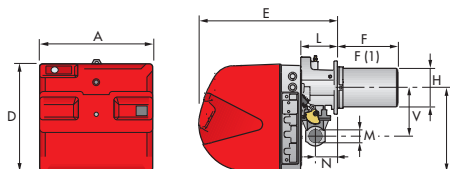

RS 45/M C05 - 55/M BLU

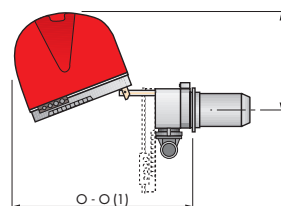
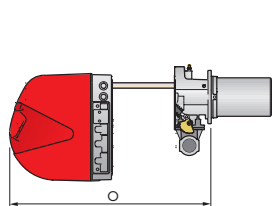
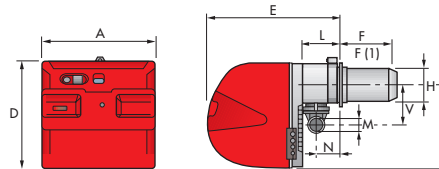

RS 68/M - 120/M - 160/M - 200/M BLU

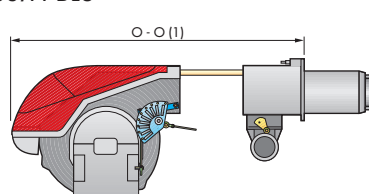
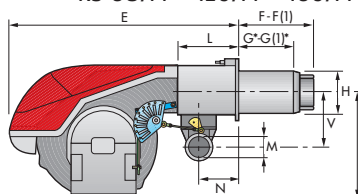
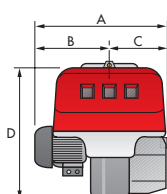

MODEL	A	B	C	D	E	F - F(1)	G* - G(1)*	H	I	L	M	N	O - O(1)	S	V
▶ RS 25/M C05	442	-	-	422	508	220 - 365	- -	140	305	138	1 1/2"	84	780 - -	-	177
▶ RS 35/M C05	442	-	-	422	508	192 - 327	- -	152	305	138	1 1/2"	84	780 - -	-	177
▶ RS 45/M C05	476	-	-	474	580	192 - 327	- -	160	352	164	1 1/2"	108	810 - 810	367	168
▶ RS 25/M BLU	442	-	-	422	508	230 - 365	- -	140	305	138	1 1/2"	84	780 - -	-	177
▶ RS 35/M BLU	442	-	-	422	508	230 - 365	- -	152	305	138	1 1/2"	84	780 - -	-	177
▶ RS 55/M BLU	533	300	-	490	640	255 - 390	- -	189	352	222	2"	134	870 - -	-	221
▶ RS 68/M BLU	527	312	215	555	840	255 - 390	200 - 335	189	430	214	2"	134	1161 - 1296	-	221
▶ RS 120/M BLU	553	338	215	555	840	255 - 390	200 - 335	189	430	214	2"	134	1161 - 1296	-	221
▶ RS 160/M BLU	671	366	305	555	863	373 - 503	272 - 402	221	436	237	2"	141	1442 - 1587	-	264
▶ RS 200/M BLU	737	432	305	555	863	373 - 503	272 - 402	221	436	237	2"	141	1442 - 1587	-	264

(1) Length with extended combustion head. * Maximum depth of the boiler door including the depth of the burner flange insulating gasket.

BURNER - BOILER MOUNTING FLANGE

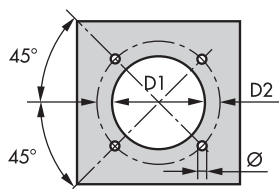

MODEL	D1	D2	Ø	MODEL	D1	D2	Ø
▶ RS 25/M C05	160	224	M8	▶ RS 55/M BLU	195	275-325	M12
▶ RS 35/M C05	160	224	M8	▶ RS 68/M BLU	195	275-325	M12
▶ RS 45/M C05	165	224	M8	▶ RS 120/M BLU	195	275-325	M12
▶ RS 25/M BLU	160	224	M8	▶ RS 160/M BLU	230	325-368	M16
▶ RS 35/M BLU	160	224	M8	▶ RS 200/M BLU	230	325-368	M16

PACKAGING

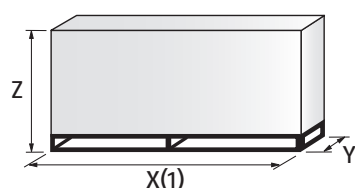

MODEL	X(1)	Y	Z	kg
▶ RS 25/M C05	1000	485	500	39
▶ RS 35/M C05	1000	485	500	40
▶ RS 45/M C05	1015	500	630	48
▶ RS 25/M BLU	1000	485	500	39
▶ RS 35/M BLU	1000	485	500	40
▶ RS 55/M BLU	1405	700	660	44
▶ RS 68/M BLU	1405	700	660	78
▶ RS 120/M BLU	1405	700	660	84
▶ RS 160/M BLU	1405-1420	1000	660	89
▶ RS 200/M BLU	1405-1420	1000	660	125

(1) dimension with standard and extended head

Low NOx Modulating Gas Burners

RS 25÷200/M BLU SERIES

Specification

DESIGNATION OF SERIES

Series:	R	
Fuel:	S	Natural Gas
	L	Light oil
	LS	Light oil/Natural Gas
	N	Heavy oil
Size:		
Setting:	/1	Single stage
	/B	Two stage
	/M	Modulating-Mechanical cam
	/E	Electronic cam
	/P	Proportioning air/gas valve
	/EV	Electronic cam predisposed for variable speed (with inverter)
	/EVi	Electronic cam with integrated inverter
Emission:	... or C01	Class 1 EN676
	MZ	Class 2 EN676
	BLU	Class 3 EN676
	MX	Class 3 EN676
	C05	Class 5 EN676 (NOx < 56 mg/kWh)
Head length:	TC	standard head
	TL	extended head
Flame control system:	FS1	Standard/Intermittent (at least 1 stop every 24 h)
	FS2	Continuous (1 stop every 72 h)
Electrical supply to the system:		
	1/230/50	1/230V/50Hz
	3/230/50	3/230V/50Hz
	3/400/50	3N/400V/50Hz
	3/230-400/50	3/230V/50Hz - 3N/400V/50Hz
	3/220/60	3/220V/60Hz
	3/380/60	3N/380V/60Hz
	3/220-380/60	3/220/60Hz - 3N/380V/60Hz
Auxiliary voltage:	230/50-60	230V/50-60H
	110/50-60	110V/50-60Hz

R	S	120	/M	BLU	TC	FS1	3/230-400/50	230/50-60
BASIC DESIGNATION				EXTENDED DESIGNATION				

RS 25÷200/M BLU SERIES

Specification

STATE OF SUPPLY

Monoblock forced draught Low NOx gas burner, two stage progressive or modulating operation with a kit, made up of:

- Air suction circuit **with sound proofing material**
- Air damper for air flow setting and butterfly valve for regulating fuel output controlled by a servomotor with variable cam
- Low emissions combustion head, that can be set on the basis of required output, fitted with:
 - stainless steel end cone, resistant to corrosion and high temperatures
 - ignition electrodes
 - ionisation probe
 - gas distributor
 - flame stability disk
- Minimum air pressure switch stops the burner in case of insufficient air quantity at the combustion head
- Burner on/off selection switch
- Manual or automatic output increase/decrease switch
- Microprocessor-based burner safety control box, with diagnostic functions
- Flame inspection window
- Slide bars for easier installation and maintenance
- Protection filter against radio interference

RS 25-35/M BLU and C05 models

- High performance fan with forward curve blades
- Starting motor at 2800 rpm, single-phase / 220-230V / 50-60Hz or three-phase / 380-400V / 50-60Hz
- Exclusive patented HCS (Housing Cooling System) with high thermal insulation and air circulation with continuous air volume refresh for an active cooling system and avoid heat transfer to the electrical component housing
- Plug and socket for electrical connections accessible from the external of the cover
- IP 40 electric protection level.

RS 45/M C05 -RS 55-68-120-160-200/M BLU models

- Fan with reverse curve blades (RS 45-55-68-120/M BLU models) or forward curve blades (RS 160-200/M BLU models)
- Sound-proofing material on air suction circuit
- Starting motor at 2800 rpm, three-phase 400V with neutral, 50Hz (single-phase, 230V, 50Hz for the RS 45/M BLU model)
- Maximum gas pressure switch (on RS 55-68-120-160-200/M BLU models)
- IP 44 electric protection level.

Standard equipment

- 1 gas train flange
- 1 flange gasket
- 4 screws for fixing the flange
- 1 thermal screen
- 4 screws for fixing the burner flange to the boiler
- Fairleads for the electrical connection (RS 45/M C05)
- 3 plugs for electrical connection (RS 25-35/M C05 single-phase)
- 4 plugs for electrical connection (RS 35/M C05 three-phase)
- 2 slide bar extensions (for extended head models and RS 160-200/M BLU models)
- Instruction handbook for installation, use and maintenance
- Spare parts catalogue.

Low NOx Modulating Gas Burners

RS 25÷200/M BLU SERIES

Available models

Burners

CODE	MODEL					HEAT OUTPUT NATURAL GAS		TOTAL ELECTRICAL POWER (kW)	CERTIFICATION	NOTE
						(kW)	(Nm ³ /h)			
3910510	RS 25/M BLU	TC	FS1	1/220-230/50-60	220-230/50-60	44/125÷370	4,5/13÷37	0,6	CE-0085BR0379	(1)
3910511	RS 25/M BLU	TL	FS1	1/220-230/50-60	220-230/50-60	44/125÷370	4,5/13÷37	0,6	CE-0085BR0379	(1)
20169244	RS 25/M BLU	TC	FS2	1/220-230/50-60	220-230/50-60	44/125÷370	4,5/13÷37	0,6	CE-0085BR0379	(1)(4)
20169245	RS 25/M BLU	TL	FS2	1/220-230/50-60	220-230/50-60	44/125÷370	4,5/13÷37	0,6	CE-0085BR0379	(1)(4)
20159191	RS 25/M C05	TC	FS1	1/220-230/50-60	220-230/50-60	70/125÷340	4,5/12,5÷34	0,6	CE-0123CT1607	(1)
20159192	RS 25/M C05	TL	FS1	1/220-230/50-60	220-230/50-60	70/125÷340	4,5/12,5÷34	0,6	CE-0123CT1607	(1)
3910610	RS 35/M BLU	TC	FS1	1/220-230/50-60	220-230/50-60	70/200÷480	7/20÷48	0,7	CE-0085BR0379	(1)
3910611	RS 35/M BLU	TL	FS1	1/220-230/50-60	220-230/50-60	70/200÷480	7/20÷48	0,7	CE-0085BR0379	(1)
20169247	RS 35/M BLU	TC	FS2	1/220-230/50-60	220-230/50-60	70/200÷480	7/20÷48	0,7	CE-0085BR0379	(1)(4)
20168390	RS 35/M BLU	TL	FS2	1/220-230/50-60	220-230/50-60	70/200÷480	7/20÷48	0,7	CE-0085BR0379	(1)(4)
20159193	RS 35/M C05	TC	FS1	1/220-230/50-60	220-230/50-60	82/200÷440	7/20÷48	0,7	CE-0123CT1607	(1)
20159194	RS 35/M C05	TL	FS1	1/220-230/50-60	220-230/50-60	82/200÷440	7/20÷48	0,7	CE-0123CT1607	(1)
20159209	RS 45/M C05	TC	FS1	1/230/50	230/50-60	90/190-570	9/19-57	0,6	CE-0123CT1607	(1)(3)
20159210	RS 45/M C05	TL	FS1	1/230/50	230/50-60	90/190-570	9/19-57	0,6	CE-0123CT1607	(1)(3)
20159481	RS 45/M C05	TC	FS2	1/230/50	230/50-60	90/190-570	9/19-57	0,6	CE-0123CT1607	(1)(3)
20159484	RS 45/M C05	TL	FS2	1/230/50	230/50-60	90/190-570	9/19-57	0,6	CE-0123CT1607	(1)(3)
20038484	RS 55/M BLU	TC	FS1	3/230-400/50	230/50-60	100/300-680	10/30-68	1,5	CE 0085CM0293	(1)
20038486	RS 55/M BLU	TL	FS1	3/230-400/50	230/50-60	100/300-680	10/30-68	1,5	CE 0085CM0293	(1)
3897406	RS 68/M BLU	TC	FS1	3/230-400/50	230/50-60	150/350-860	15/35-86	1,8	CE 0085 BM0452	(2)
3897407	RS 68/M BLU	TL	FS1	3/230-400/50	230/50-60	150/350-860	15/35-86	1,8	CE 0085 BM0452	(2)
3866211	RS 68/M BLU	TC	FS1	3/230-400/50	230/50-60	150/350-860	15/35-86	1,8	CE 0085 BM0452	(1)
3866212	RS 68/M BLU	TL	FS1	3/230-400/50	230/50-60	150/350-860	15/35-86	1,8	CE 0085 BM0452	(1)
20169249	RS 68/M BLU	TC	FS2	3/230-400/50	230/50-60	150/350-860	15/35-86	1,8	CE 0085 BM0452	(2)(4)
20169248	RS 68/M BLU	TL	FS2	3/230-400/50	230/50-60	150/350-860	15/35-86	1,8	CE 0085 BM0452	(2)(4)
3897606	RS 120/M BLU	TC	FS1	3/230-400/50	230/50-60	300/600-1300	30/60-130	2,6	CE 0085 BM0452	(2)
3897607	RS 120/M BLU	TL	FS1	3/230-400/50	230/50-60	300/600-1300	30/60-130	2,6	CE 0085 BM0452	(2)
3866213	RS 120/M BLU	TC	FS1	3/230-400/50	230/50-60	300/600-1300	30/60-130	2,6	CE 0085 BM0452	(1)
(A)	RS 120/M BLU	TL	FS1	3/230-400/50	230/50-60	300/600-1300	30/60-130	2,6	CE 0085 BM0452	(1)
20009506	RS 120/M BLU	TL	FS1	3/220-380/60	230/50-60	300/600-1300	30/60-130	2,6	-	(2)
20169243	RS 120/M BLU	TC	FS2	3/230-400/50	230/50-60	300/600-1300	30/60-130	2,6	CE 0085 BM0452	(2)(4)
20168391	RS 120/M BLU	TL	FS2	3/230-400/50	230/50-60	300/600-1300	30/60-130	2,6	CE 0085 BM0452	(2)(4)
3788006	RS 160/M BLU	TC	FS1	3/400/50	230/50-60	300/930-1860	30/93-186	4,8	CE 0085 BM0452	(2)
20011709	RS 160/M BLU	TC	FS1	3/230/50	230/50-60	300/930-1860	30/93-186	4,8	CE 0085 BM0452	(2)
3788007	RS 160/M BLU	TL	FS1	3/400/50	230/50-60	300/930-1860	30/93-186	4,8	CE 0085 BM0452	(2)
3866214	RS 160/M BLU	TC	FS1	3/400/50	230/50-60	300/930-1860	30/93-186	4,8	CE 0085 BM0452	(1)
(A)	RS 160/M BLU	TL	FS1	3/400/50	230/50-60	300/930-1860	30/93-186	4,8	CE 0085 BM0452	(1)
20006048	RS 160/M BLU	TC	FS1	3/380/60	230/50-60	300/930-1860	30/93-186	4,8	-	(2)
20006069	RS 160/M BLU	TL	FS1	3/380/60	230/50-60	300/930-1860	30/93-186	4,8	-	(2)
20168492	RS 160/M BLU	TC	FS2	3/400/50	230/50-60	300/930-1860	30/93-186	4,8	CE 0085 BM0452	(2)(4)

RS 25÷200/M BLU SERIES

Available models

Burners

CODE	MODEL	HEAT OUTPUT NATURAL GAS		TOTAL ELECTRICAL POWER (kW)	CERTIFICATION	NOTE
		(kW)	(Nm ³ /h)			
20169219	RS 160/M BLU TL FS2 3/400/50 230/50-60	300/930-1860	30/93-186	4,8	CE 0085 BM0452	(2)(4)
3899710	RS 200/M BLU TC FS1 3/400/50 230/50-60	570/1375-2400	57/138-240	8,2	CE 0085 BT0414	(2)
3899711	RS 200/M BLU TL FS1 3/400/50 230/50-60	570/1375-2400	57/138-240	8,2	CE 0085 BT0414	(2)
3899740	RS 200/M BLU TC FS1 3/230/50 230/50-60	570/1375-2400	57/138-240	8,2	CE 0085 BT0414	(2)
(A)	RS 200/M BLU TC FS2 3/400/50 230/50-60	570/1375-2400	57/138-240	8,2	CE 0085 BT0414	(2)
(A)	RS 200/M BLU TL FS2 3/400/50 230/50-60	570/1375-2400	57/138-240	8,2	CE 0085 BT0414	(2)
(A)	RS 200/M BLU TC FS2 3/230/50 230/50-60	570/1375-2400	57/138-240	8,2	CE 0085 BT0414	(2)
(A)	RS 200/M BLU TL FS2 3/230/50 230/50-60	570/1375-2400	57/138-240	8,2	CE 0085 BT0414	(2)

(A) Please contact Riello Burners Commercial and Technical Department, our Application Engineers will be pleased to help you.

Natural gas, net calorific value: 10 kWh/Nm³ - Density: 0,71 kg/Nm³

The burners of RS/M BLU series are in according to 2016/426/EU - 2014/30/EU - 2014/35/EU - 2006/42 EC Directive and EN 676 - LRV 92 Norm.

(1) With plug and socket.

(2) With terminal board.

(3) RS 45/M C05 codes listed above will be actually available for orders progressively during year 2019. In the meanwhile, the RS 45/M BLU old codes will remain active as temporary substitutes. The table below shows the correspondence.

(4) with RFG0 control box

MODEL	(RS 45/M C05) NEW CODE	(RS 45/M BLU) OLD CODE
TC FS1 1/230/50 230/50-60	20159209	3897306
TL FS1 1/230/50 230/50-60	20159210	3897307
TC FS2 1/230/50 230/50-60	20159481	3897312
TL FS2 1/230/50 230/50-60	20159484	3897313

Due to the improvement applied on the technical specification of some products, some burner codes will change during year 2019. The table below summarizes the correspondence between the previous and the new code.

MODEL	NEW CODE	OLD CODE
RS 25/M BLU TC FS2 1/220-230/50-60	20169244 (4)	3910520
RS 25/M BLU TL FS2 1/220-230/50-60	20169245 (4)	3910521
RS 35/M BLU TC FS2 1/220-230/50-60	20169247 (4)	3910620
RS 35/M BLU TL FS2 1/220-230/50-60	20168390 (4)	3910621
RS 68/M BLU TC FS2 3/230-400/50	20169249 (4)	3897420
RS 68/M BLU TL FS2 3/230-400/50	20168248 (4)	3897421
RS 120/M BLU TC FS2 3/230-400/50	20169243 (4)	3897620
RS 120/M BLU TL FS2 3/230-400/50	20168391 (4)	3897621
RS 160/M BLU TC FS2 3/400/50	20168492 (4)	3788011
RS 160/M BLU TL FS2 3/400/50	20169219 (4)	3788012

Low NOx Modulating Gas Burners

RS 25÷200/M BLU SERIES

Available models

Gas Trains

CODE	GAS TRAIN				VPS Code	ADAPTER CODE						
	MODEL	∅	C.T.			RS 25	RS 35 RS 45	RS 55	RS 68	RS 120	RS 160	RS 200
3970500*	MB 405/1 - RT 20	Rp 3/4"	-	3010123				●	●	●	●	●
3970553*	MB 407/1 - RT 20	Rp 3/4"	-	3010123				●	●	●	●	●
3970599*	MB 407/1 - RT 52	Rp 3/4"	-	3010123				●	●	●	●	●
3970229*	MB 407/1 - RSM 20	Rp 3/4"	-	3010123				●	●	●	●	●
3970258*	MB 410/1 - RT 52	Rp 1" 1/4	-	3010123	3010124			3010126			●	●
3970554*	MB 410/1 - RT 20	Rp 3/4"	-	3010123							●	●
3970600*	MB 410/1 - RT 52	Rp 3/4"	-	3010123				3000824 + 3000843			●	●
3970230*	MB 410/1 - RSM 20	Rp 3/4"	-	3010123							●	●
3970256*	MB 412/1 - RT 52	Rp 1" 1/2	-	3010123	□							●
3970144*	MB 412/1 - RT 20	Rp 1" 1/2	-	3010123	□			3000843				●
3970197**	MB 412/1 CT RT 20	Rp 1" 1/2	◆	-	□			3000843				●
3970231*	MB 412/1 - RSM 20	Rp 1" 1/2	-	3010123	□							●
3970180*	MB 415/1 - RT 30	Rp 1" 1/2	-	3010123	□							
3970198**	MB 415/1 CT RT 30	Rp 1" 1/2	◆	-	□							
3970250*	MB 415/1 - RT 52	Rp 1" 1/2	-	3010123	□			3000843				
3970253**	MB 415/1 CT RT 52	Rp 1" 1/2	◆	-	□							
3970232*	MB 415/1 - RSM 30	Rp 1" 1/2	-	3010123	□							
3970181*	MB 420/1 - RT 30	Rp 2"	-	3010123					□			
3970182**	MB 420/1 CT RT 30	Rp 2"	◆	-					□			
3970257*	MB 420/1 - RT 52	Rp 2"	-	3010123					□			
3970252**	MB 420/1 CT RT 52	Rp 2"	◆	-					□			
3970233*	MB 420/1 - RSM 30	Rp 2"	-	3010123					□			
3970234**	MB 420/1 CT RSM 30	Rp 2"	◆	-					□			
3970221*	MBC 1200/1 - RSM 60	Rp 2"	-	3010123					□			
3970225**	MBC 1200/1 CT RSM 60	Rp 2"	◆	-					□			
3970222*	MBC 1900/1 - FSM 40	DN 65	-	3010123		●		3000825				
3970226**	MBC 1900/1 CT FSM 40	DN 65	◆	-		●		3000825				
3970223*	MBC 3100/1 - FSM 40	DN 80	-	3010123		●	●	3000826				
3970227**	MBC 3100/1 CT FSM 40	DN 80	◆	-		●	●	3000826				
3970224*	MBC 5000/1 - FSM 80	DN 100	-	3010123		●	●	●	●	●	●	3010370 +
3970228**	MBC 5000/1 CT FSM 80	DN 100	◆	-		●	●	●	●	●	●	3000826
3970145*	CB 512/1 - RSM 30	Rp 1" 1/2	-	3010123	□			3000843				
20045589**	CB 512/1 CT RSM 30	Rp 1" 1/2	◆	-	□			3000843				

Please see designation of Gas Train Series in the page before the Catalogue index.

* 230V/50Hz ~220V/60Hz electrical supply.

** 230V/50Hz electrical supply.

The valve seal control device is compulsory (conforming to EN 676) on gas trains to burners with a maximum output over 1200 kW.

To select the gas train please refer to the technical data leaflet and/or instruction manual.

C.T. Gas valve leak detection control device:

- gas train not equipped with leak detection control device; this device can be ordered separately - see VPS column - and installed later.

◆ gas train equipped with leak detection control device.

VPS Valve leak detection control device. Supplied separately from the gas train (please see Gas train accessories paragraph for both 50 Hz and 60 Hz codes).

● Not available.

□ Additional adapter not necessary, the gas train may be connected directly to the burner.

RS 25÷200/M BLU SERIES

Available models

Gas Trains

CODE	GAS TRAIN				ADAPTER CODE						
	MODEL	∅	C.T.	VPS Code	RS 25	RS 35 RS 45	RS 55	RS 68	RS 120	RS 160	RS 200
3970146*	CB 520/1 - RSM 30	Rp 2"	-	3010123							
3970160**	CB 520/1 CT RSM 30	Rp 2"	◆	-							
20044659*	CB 525/1 - RSM 30	Rp 2"	-	3010123							
20044660**	CB 525/1 CT RSM 30	Rp 2"	◆	-							
3970147*	CB 5065/1 - FSM 30	DN 65	-	3010123	●						
3970161**	CB 5065/1 CT FSM 30	DN 65	◆	-	●						
3970148*	CB 5080/1 - FSM 30	DN 80	-	3010123	●	●					
3970162**	CB 5080/1 CT FSM 30	DN 80	◆	-	●	●					
3970149*	CB 50100/1 - FSM 30	DN 100	-	3010123	●	●	●				
3970163**	CB 50100/1 CT FSM 30	DN 100	◆	-	●	●	●				
20015871*	CB 50125/1 - FSM 30	DN 125	-	3010123	●	●	●	●			
3970196**	CB 50125/1 CT FSM 30	DN 125	◆	-	●	●	●	●			

Please see designation of Gas Train Series in the page before the Catalogue index.

* 230V/50Hz -220V/60Hz electrical supply.

** 230V/50Hz electrical supply.

The valve seal control device is compulsory (conforming to EN 676) on gas trains to burners with a maximum output over 1200 kW.

To select the gas train please refer to the technical data leaflet and/or instruction manual.

C.T. Gas valve leak detection control device:

- gas train not equipped with leak detection control device; this device can be ordered separately - see VPS column - and installed later.

◆ gas train equipped with leak detection control device.

VPS Valve leak detection control device. Supplied separately from the gas train (please see Gas train accessories paragraph for both 50 Hz and 60 Hz codes).

● Not available.

□ Additional adapter not necessary, the gas train may be connected directly to the burner.

Low NOx Modulating Gas Burners

RS 25÷200/M BLU SERIES

Burner accessories

All RS 25-35-45/M BLU accessories listed below are available also for the correspondent RS/M C05 models.

Extended head kit

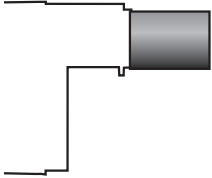

“Standard head” burners can be transformed into “extended head” versions, by using the special kit. The KITS available for the various burners, giving the original and the extended lengths, are listed below.

BURNER	STANDARD HEAD LENGTH (mm)	EXTENDED HEAD LENGTH (mm)	KIT CODE
▶ RS 25/M BLU - C05	230	365	3010430
▶ RS 35/M BLU - C05	230	365	3010431
▶ RS 45/M BLU - C05	229	354	3010240
▶ RS 55/M BLU	255	390	20040373
▶ RS 68/M - 120/M BLU	255	390	3010177
▶ RS 160/M BLU	373	503	3010442 *
▶ RS 200/M BLU	373	503	3010474

* Kit to be used on burners recognizable by a serial number that is over or equal to 02426XXXXXX, for burners with a serial number that is under or equal to 02416XXXXXX please use the Kit coded 3010193

Spacer kit

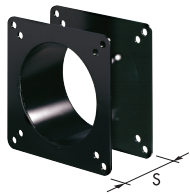

If burner head penetration into the combustion chamber needs reducing, varying thickness spacers are available, as given in the following list.

BURNER	SPACER THICKNESS S (mm)	KIT CODE
▶ RS 25/M - 35/M - 45/M BLU - C05	110	3010095
▶ RS 55/M - 68/M - 120/M BLU	135	3010129
▶ RS 160/M - 200/M BLU	102	3000722

Continuous ventilation kit



If the burner requires continuous ventilation in the stages without flame, a special kit is available as given in the following table.

BURNER	KIT CODE
▶ RS 25/M - 35/M BLU - C05	3010449
▶ RS 45/M- C05 - 55/M - 68/M - 120/M - 160/M - 200/M BLU	3010094

Sound proofing box

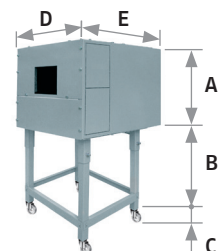

If noise emission needs reducing even further, sound-proofing boxes are available. When a lower “B” dimension is required, it is available the Box Support Kit code 20065135 which allows to reduce it at the fixed dimension of 55 mm. The sound-proofing boxes are not suitable for outdoor use.

BURNER	BOX TYPE	A (mm)	B (mm) min-max	C (mm)	D (mm)	E (mm)	[dB(A)] (*)	BOX CODE
▶ RS 25/M - 35/M BLU - C05 ▶ RS 45/M- C05 - 55/M BLU	C1/3	650	372 - 980	110	690	770	10	3010403
▶ RS 68/M - 120/M BLU ▶ RS 160/M - 200/M BLU	C4/5	850	160 - 980	110	980	930	10	3010404

(*) Average noise reduction according to EN 15036-1 standard

RS 25÷200/M BLU SERIES

Burner accessories

Accessories for modulating operation



To obtain modulating operation, the RS/M BLU series of burners requires a regulator with three point outlet controls. On RS 25/M - 35/M BLU the regulator is connected to the burner electrical wiring by plug-in system in order to make the connection easier and faster.

The following table lists the accessories for modulating operation with their application range.

For remote setpoint use RWF 55.

BURNER	REGULATOR TYPE	REGULATOR CODE
▶ RS 25/M - 35/M C05	RWF 50.2	20083339
	RWF 55.5	20098541
▶ RS 45/M BLU - C05	RWF 50.2	20082208
	RWF 55.5	20099657
▶ RS 55/M BLU	RWF 50.2	20101190
	RWF 55.5	20101191
▶ RS 68/M - 120/M BLU	RWF 50.2	20082208
	RWF 55.5	20099657
▶ RS 160/M - 200/M BLU	RWF 50.2	20099869
	RWF 55.5	20099905



The relative temperature or pressure probes fitted to the regulator, must be chosen on the basis of the application.

BURNER	PROBE TYPE	RANGE (°C) (bar)	PROBE CODE
▶ All models	Temperature PT 100	-100 ÷ 500°C	3010110
	Pressure 4 ÷ 20 mA	0 ÷ 2,5 bar	3010213
	Pressure 4 ÷ 20 mA	0 ÷ 16 bar	3010214
	Pressure 4 ÷ 20 mA	0 ÷ 25 bar	3090873



Modulating operation can also be obtained with an analog control signal converter and a feedback three-pole potentiometer.

Alternatively, the potentiometer can be used to check the servomotor position.

BURNER	TYPE (INPUT SIGNAL)	KIT CODE
▶ RS 25/M - 35/M BLU - C05	0/2 - 10 V (impedance 200 KΩ) 0/4 - 20 mA (impedance 250 Ω)	3010410
▶ RS 45/M BLU- C05 - 55/M	0/2 - 10 V (impedance 200 KΩ) 0/4 - 20 mA (impedance 250 Ω)	3010390
▶ RS 68/M - 120/M - 160/M - 200/M BLU	0/2 - 10 V (impedance 200 KΩ) 0/4 - 20 mA (impedance 250 Ω)	3010415

Low NOx Modulating Gas Burners

RS 25÷200/M BLU SERIES

Burner accessories

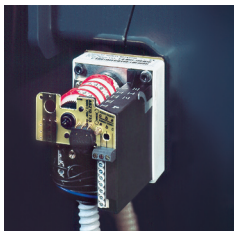

Depending on the servomotor fitted to the burner, a three-pole potentiometer (1000 Ω) can be installed to check the position of the servomotor. The KITS available for the various burners are listed below.

BURNER	POTENTIOMETER KIT CODE
▶ RS 25/M – 35/M BLU – C05	3010420
▶ RS 45/M – C05 – 55/M BLU	3010109
▶ RS 68/M – 120/M – 160/M – 200/M BLU	3010416

Head kit for “reverse flame chamber”



In certain cases, the use of the burner on reverse flame boilers can be improved by using an additional Pipes Kit.

BURNER	KIT CODE (*)
▶ RS 68/M BLU	3010247
▶ RS 120/M BLU	3010248
▶ RS 160/M BLU	3010249
▶ RS 200/M BLU	20035848

(*) CE approval on field is required

Ground fault interrupter kit



A “Ground fault interrupter kit” is available as a safety device in case of electrical system fault.

BURNER	KIT CODE
▶ RS 25/M – 35/M BLU – C05	3010448
▶ RS 45/M – C05 – 55/M – 68/M – 120/M – 160/M – 200/M BLU	3010329

Gas max pressure switch

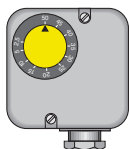

If necessary a Gas max pressure Switch kit is available and connectable to the burner electrical wiring trough Plugs & Sockets system.

BURNER	KIT CODE
▶ RS 25/M – 35/M BLU – C05	3010418

Volt free contact kit



A volt free contact kit is available for installation onto the burner. It can be used for a remote interface between burner operating signals. Every burner can be equipped with a single kit for a remote check of the flame presence signal and the burner lock-out indication.

BURNER	KIT CODE
▶ RS 25/M – 35/M – C05 – 55/M BLU	3010419

RS 25÷200/M BLU SERIES

Burner accessories

DN80 gas flange kit

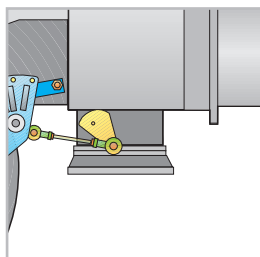

To modify the standard 2" burner gas input connection in to DN80 connection, a specific gas flange is available.

BURNER	KIT CODE
▶ RS 68/M - 120/M - 160/M - 200/M BLU	3010439

Post-ventilation kit

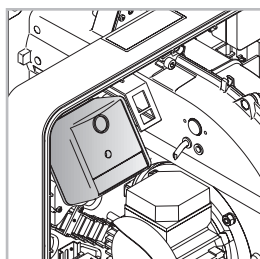

To have 20 s ventilation after opening of thermostats chain, a special kit is available.

BURNER	KIT CODE
▶ RS 25/M - 35/M BLU - C05	3010451

Hours counter kit

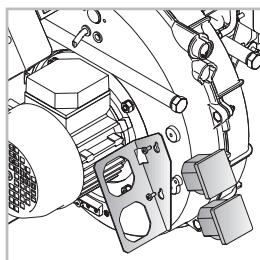

To measure the burner working time a hours counter kit is available.

BURNER	KIT CODE
▶ RS 25/M - 35/M BLU - C05	3010450

LPG kit

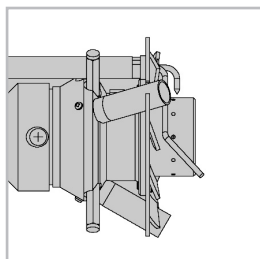

For burning LPG gas, a special kit is available to be fitted to the combustion head on the burner, as given in the following table.

BURNER	KIT CODE FOR STANDARD HEAD	KIT CODE FOR EXTENDED HEAD
▶ RS 25/M BLU - C05	3010423	3010423
▶ RS 35/M BLU- C05	3010424	3010424
▶ RS 45/M BLU- C05	3010432 *	3010432 *
▶ RS 55/M BLU	20144368 *	20161511 *
▶ RS 68/M BLU	3010433 *	3010433 *
▶ RS 120/M BLU	(1)	(1)
▶ RS 160/M BLU	20008971 *	20008971 *
▶ RS 200/M BLU	3010491	3010491

(*) CE approval on field is required.

(1) Not available

Low NOx Modulating Gas Burners

RS 25÷200/M BLU SERIES

Burner accessories

Protection kit (electromagnetic interferences)

When the burner is installed in a room particularly subject to electromagnetic interference (signals emitted over 10 V/m) due for example to INVERTER presence or in systems where the lengths of the thermostat connections is over 20 meters, this specific protection kit is available as an interface between the thermostatic controls and the burner.

BURNER	KIT CODE
► All models	3010386

PC Interface kit



To connect the RMG control box to a personal computer for the transmission of operation, fault signals and detailed service information, an interface adapter with PC software are available.

BURNER	KIT CODE
► All models	3002719

Uv Flame sensor



UV90L flame sensor can be used only with the RFG0 control box and when the LFL control box with UV flame sensor type QRA2 must be replaced.









BURNER	KIT CODE
► All RS/M models (*)	On demand

(*) Only with RFG0 control box.

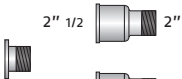
Gas train accessories

Adapters

When the diameter of the gas train is different from the set diameter of the burners, an adapter must be fitted between the gas train and the burner. Below are given the available adapters; please see on the Gas Train list the correct adapter codes to select.

ADAPTER	LENGTH mm	ADAPTER CODE
2"  1" 1/2	70	3000822
3/4"  1" 1/2	31	3000824
DN 65  2" 1/2  1" 1/2	300	3000825
DN 80  2" 1/2  2"	300	3000826
1" 1/2  2"	35	3000843
1" 1/4  1" 1/2	35	3010124
1" 1/4  2"	35	3010126

Seal control kit



To test the valve seals on the gas train, a special "seal control kit" is available. The valve seal control device is compulsory (EN 676) on gas trains to burners with a maximum output over 1200 kW. The seal control is type VPS 504.

GAS TRAIN	KIT CODE	KIT CODE
	for 50 Hz operation	for 60 Hz operation
▶ MB/1 type	3010123	20168805
▶ MBC/1 type	3010123	20168805
▶ CB/1 type	3010123	20168805

Gas train accessories

Stabiliser spring



To vary the pressure range of the gas train stabilisers, accessory springs are available. The following table shows these accessories with their application range. Please refer to the technical manual for the correct choice of spring.

GAS TRAIN	SPRING COLOUR	SPRING PRESSURE RANGE mbar	SPRING CODE
▶ MBC 1900/1 - 3100/1	White	4 - 20	3010381
	Red	20 - 40	3010382
	Black	40 - 80	3010383
	Green	80 - 150	3010384
▶ CB 512/1	Red	25 - 55	3010131
	Black	60 - 110	3010157
	Pink	90 - 150	3090486
▶ CB 520/1 - 525/1	Red	25 - 55	3010132
	Black	60 - 110	3010158
	Pink	100 - 150	3090487
▶ CB 5065/1 - 5080/1	Red	25 - 55	3010133
	Black	60 - 110	3010135
	Pink	100 - 150	3090456
	Grey	140 - 200	3090992

RS 25÷200/E-/EV BLU SERIES

The RS/E C05, BLU and RS/EV BLU burners series covers a firing range from 44 to 2400 kW, and it is based on a new Digital Burner Management System, Riello REC27-37, which is able to manage the air-fuel ratio by independent servomotors in order to obtain a perfect output control and to assure a correct combustion and safe operation on all modulation range. Operation can be "two stage progressive" or, alternatively, "modulating" with the installation of a PID logic regulator and respective probes.

RS/E BLU burners series guarantees high efficiency levels in all the various applications, thus reducing fuel consumption and running costs; specific versions are available to operate with Variable Speed Drive technology base on the control of a Frequency Inverter that modifies the air flow through the motor speed variation. Optimisation of sound emissions is guaranteed by the special design of the air suction circuit and by incorporated sound proofing material.

Guidelines for installation of burners in conformity to EU Regulation:

A RIELLO burner (Heat Generator), where it is matched with a water-based boiler (Heater Housing) with a nominal output ≤ 400 kW, providing heat for heating purposes and heat to deliver sanitary hot water, can be installed:

- With boilers (heater housings) already in service in the field, for replacement of identical products, in conformity to Article 1, paragraph 2, point (G) of the EU Regulation No. 813/2013;
- With boilers (heater housings) on a new installation.



RS 25/E C05	70/125 ÷ 340 kW
RS 35/E C05	82/200 ÷ 440 kW
RS 45/E C05	90/190 ÷ 570 kW

RS 25/E BLU	45/125 ÷ 370 kW
RS 35/E BLU	72/202 ÷ 480 kW
RS 55/E BLU	100/300 ÷ 680 kW
RS 68/E-/EV BLU	150/350 ÷ 860 kW
RS 120/E-/EV BLU	300/600 ÷ 1300 kW
RS 160/E-/EV BLU	300/930 ÷ 1860 kW
RS 200/E-/EV BLU	570/1375 ÷ 2400 kW

FIRING RATES

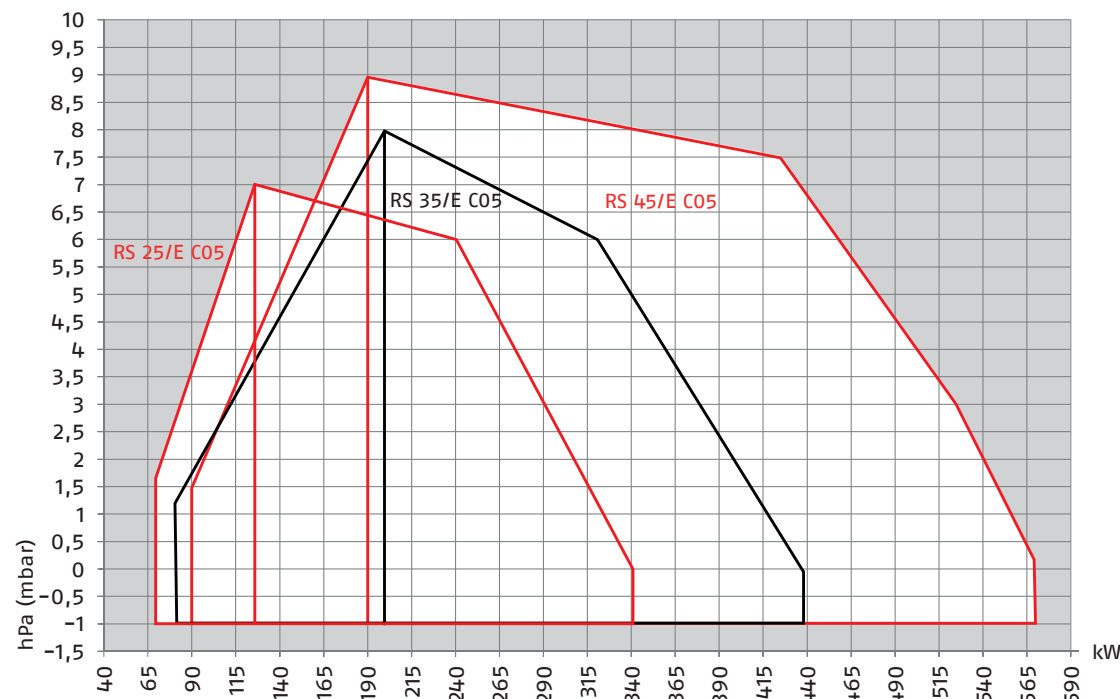

□ Useful working field for choosing the burner

▭ Modulation range

Test conditions conforming to EN676
 Temperature: 20°C
 Pressure: 1013,5 mbar
 Altitude: 0 m a.s.l.

Low NOx Modulating Gas Burners

RS 25÷200/E-E/V BLU SERIES

FIRING RATES

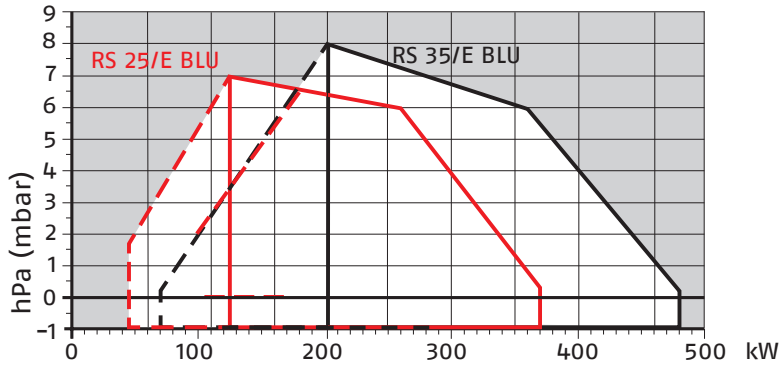

□ Useful working field for choosing the burner

▤ Modulation range

Test conditions conforming to EN676
 Temperature: 20°C
 Pressure: 1013,5 mbar
 Altitude: 0 m a.s.l.

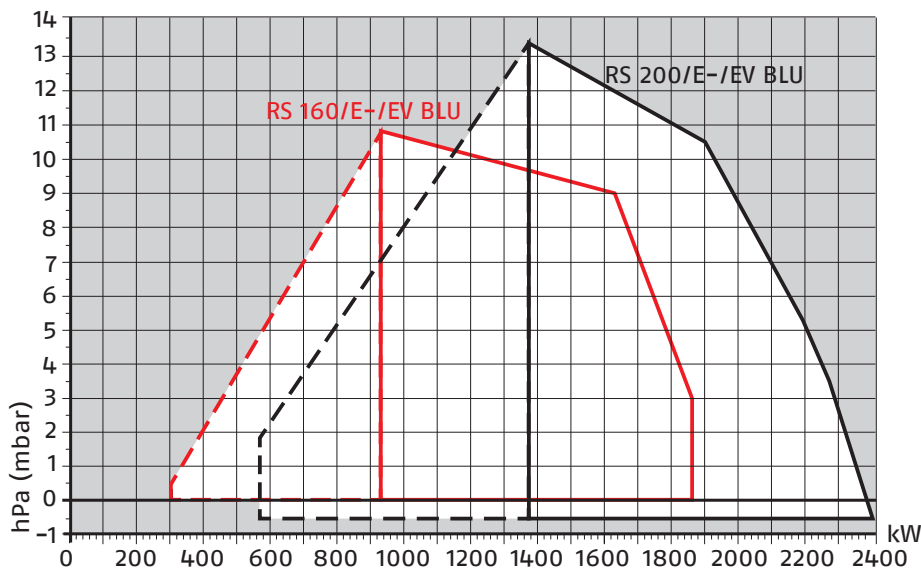
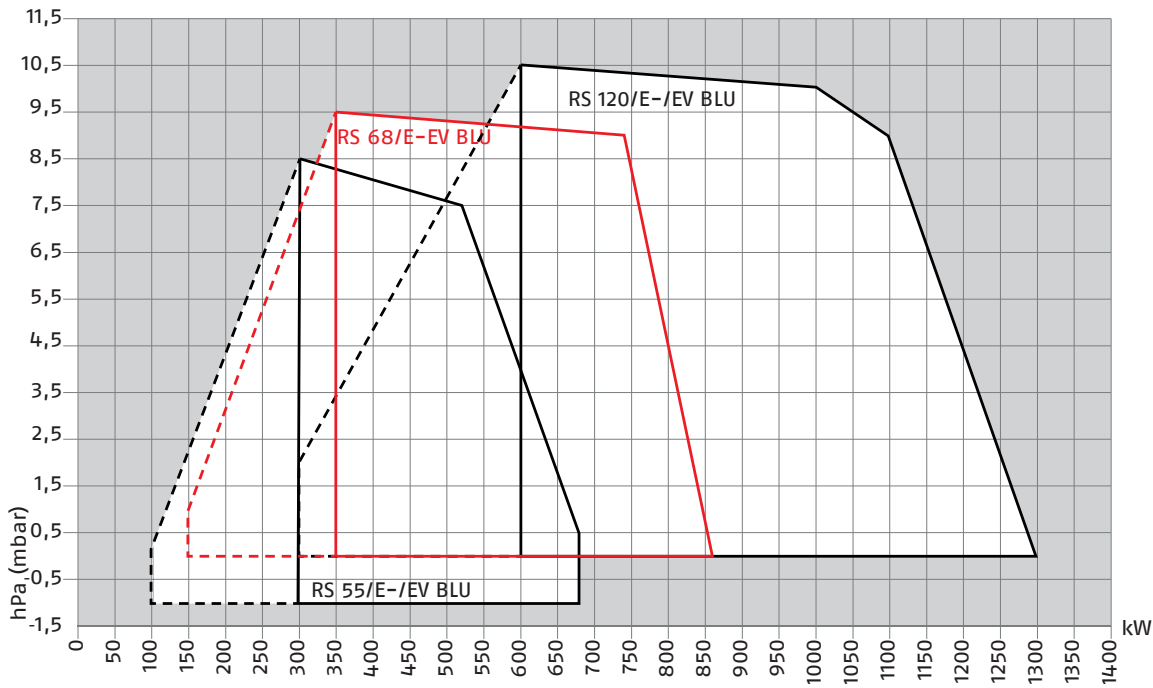

Overall dimensions (mm)

BURNER

RS 25/E - 35/E BLU - RS 25/E - 35/E C05

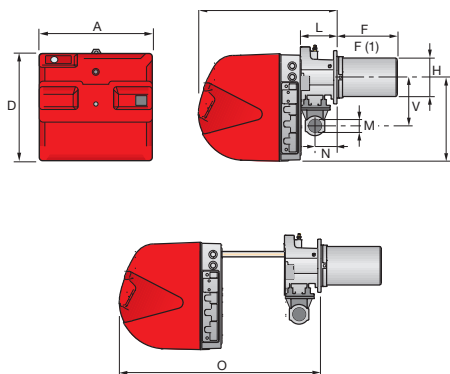

RS 45/E C05 - RS 55/E BLU

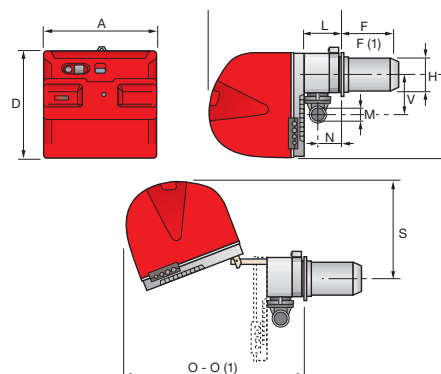

RS 68/E-EV - 120/E-EV - 160/E-EV - 200/E-EV BLU

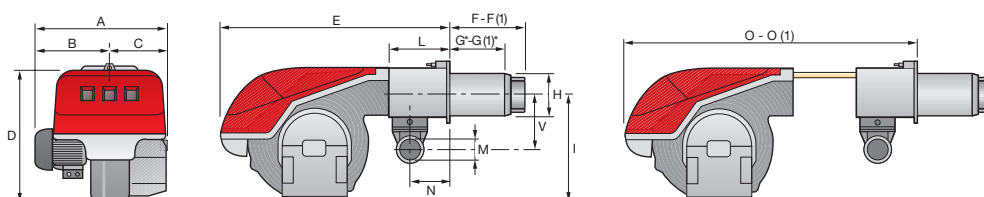

MODEL	A	B	C	D	E	F - F (1)	G* - G(1)*	H	I	L	M	N	O - O(1)	S	V
▶ RS 25/E C05	442	-	-	422	508	230 - 365	- -	140	305	138	1 1/2"	84	780 - -	-	177
▶ RS 35/E C05	442	-	-	422	508	192 - 327	- -	152	305	138	1 1/2"	84	780 - -	-	177
▶ RS 45/E C05	476	-	-	474	580	192 - 327	- -	160	352	164	1 1/2"	108	810 - 810	367	168
▶ RS 25/E BLU	442	-	-	422	508	230 - 365	- -	140	305	138	1 1/2"	84	780 - -	-	177
▶ RS 35/E BLU	442	-	-	422	508	230 - 365	- -	152	305	138	1 1/2"	84	780 - -	-	177
▶ RS 55/E BLU	533	300	-	490	640	255 - 390	- -	189	352	222	2"	134	870 - -	-	221
▶ RS 68/E-EV BLU	527	312	215	555	840	255 - 390	200 - 335	189	430	214	2"	134	1161 - 1296	-	221
▶ RS 120/E-EV BLU	553	338	215	555	840	255 - 390	200 - 335	189	430	214	2"	134	1161 - 1296	-	221
▶ RS 160/E-EV BLU	671	366	305	555	863	373 - 503	272 - 402	221	436	221	2"	141	1442 - 1587	-	264
▶ RS 200/E-EV BLU	737	432	305	555	863	373 - 503	272 - 402	221	436	221	2"	141	1442 - 1587	-	264

(1) dimension with extended head.

* Maximum depth of the boiler door including the depth of the burner flange insulating gasket.

Low NOx Modulating Gas Burners

RS 25÷200/E-/EV BLU SERIES

Overall dimensions (mm)

BURNER - BOILER MOUNTING FLANGE

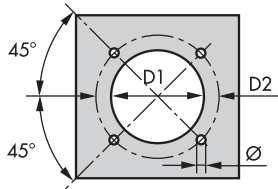

MODEL	D1	D2	Ø
▶ RS 25/E C05	160	224	M8
▶ RS 35/E C05	160	224	M8
▶ RS 45/E C05	165	224	M8
▶ RS 25/E BLU	160	224	M8
▶ RS 35/E BLU	160	224	M8
▶ RS 55/E BLU	195	275-325	M12
▶ RS 68/E-EV BLU	195	275-325	M12
▶ RS 120/E-EV BLU	195	275-325	M12
▶ RS 160/E-EV BLU	230	325-368	M16
▶ RS 200/E-EV BLU	230	325-368	M16

PACKAGING

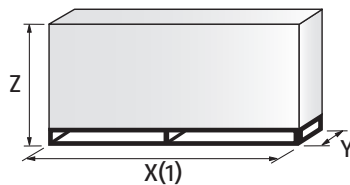

MODEL	X(1)	Y	Z	kg
▶ RS 25/E C05	1000	485	500	39
▶ RS 35/E C05	1000	485	500	40
▶ RS 45/E C05	1015	500	630	48
▶ RS 25/E BLU	1000	485	500	39
▶ RS 35/E BLU	1000	485	500	40
▶ RS 55/E BLU	1405	700	660	44
▶ RS 68/E-EV BLU	1405	700	660	78
▶ RS 120/E-EV BLU	1405	700	660	84
▶ RS 160/E-EV BLU	1405-1420	1000	660	89
▶ RS 200/E-EV BLU	1405-1420	1000	660	125

(1) dimension with standard and extended head

RS 25÷200/E-/EV BLU SERIES

Specification

DESIGNATION OF SERIES

Series: R

Fuel: S Natural Gas

L Light oil

LS Light oil/Natural Gas

N Heavy oil

Size:

Setting: /1 Single stage

/B Two stage

/M Modulating-Mechanical cam

/E Electronic cam

/P Proportioning air/gas valve

/EV Electronic cam predisposed for variable speed (with inverter)

/EVi Electronic cam with integrated inverter

Emission: ... or C01 Class 1 EN676

MZ Class 2 EN676

BLU Class 3 EN676

MX Class 3 EN676

C05 Class 5 EN676 (NOx < 56 mg/kWh)

Head length: TC standard head

TL extended head

Flame control system: FS1 Standard/Intermittent (at least 1 stop every 24 h)

FS2 Continuous (1 stop every 72 h)

Electrical supply to the system:

1/230/50 1/230V/50Hz

3/230/50 3/230V/50Hz

3/400/50 3N/400V/50Hz

3/230-400/50 3/230V/50Hz - 3N/400V/50Hz

3/220/60 3/220V/60Hz

3/380/60 3N/380V/60Hz

3/220-380/60 3/220V/60Hz - 3N/380V/60Hz

Auxiliary voltage: 230/50-60 230V/50-60H

110/50-60 110V/50-60Hz

R S 120 /E BLU TC FS1 3/230-400/50 230/50-60

BASIC DESIGNATION

EXTENDED DESIGNATION

Low NOx Modulating Gas Burners

RS 25÷200/E-/EV BLU SERIES

Specification

STATE OF SUPPLY

RS 25/E – 35/E BLU and C05 models

Monoblock forced draught Low NOx gas burner with two stage progressive or modulating operation, with a specific kit, fully automatic, made up of:

- Microprocessor-based Digital Burner Management System (RS/E models)
- Display Interface operating unit to adjust the system
- Air suction circuit **with sound proofing material**
- High performance fan with straight blades
- Air damper for air flow setting and butterfly valve for regulating fuel output controlled by independent stepper motor actuators
- Starting motor at 2800 rpm, single-phase/220-230V/50-60Hz or three-phase/380-400V/50-60Hz
- low emission combustion head, that can be set on the basis of required output, fitted with:
 - stainless steel end cone, resistant to corrosion and high temperatures
 - ignition electrodes
 - ionisation probe
 - gas distributor
 - flame stability disk
- Exclusive patented HCS (Housing Cooling System) with high thermal insulation and air circulation with continuous air volume refresh for an active cooling system and avoid heat transfer to the electrical component housing
- Minimum air pressure switch stops the burner in case of insufficient air quantity at the combustion head
- Plugs and sockets for electrical connection, accessible from the external of the cover
- Burner on/off selection switch
- Flame inspection window
- Slide bars for easier installation and maintenance
- Protection filter against radio interference
- IP X0D (IP 40) electric protection level.

Standard equipment:

- 1 gas train flange
- 1 flange gasket
- 4 screws for fixing the flange
- 1 thermal screen
- 4 screws for fixing the burner flange to the boiler
- 3 plugs for electrical connection (RS 25-35/E C05 single-phase)
- 4 plugs for electrical connection (RS 35/E C05 three-phase)
- Instruction handbook for installation, use and maintenance
- Spare parts catalogue.

RS 25÷200/E-/EV BLU SERIES

Specification

STATE OF SUPPLY

RS 45/E C05 - 55/E - 68/E-EV - 120/E-EV - 160/E-EV - 200/E-EV BLU models

Monoblock forced draught Low NOx gas burner with two stage progressive or modulating operation, with a specific kit, fully automatic, made up of:

- Microprocessor-based Digital Burner Management System (RS/E C05 models)
- Microprocessor-based Digital Burner Management System with Variable Speed Drive technology for the control of a Frequency Inverter (RS/EV BLU models)
- Display Interface operating unit to adjust the system
- Air suction circuit lined with sound-proofing material
- Fan with reverse curve blades (straight blades on the 160/E-EV - 200/E-EV BLU model) high performance with low sound emissions
- Air damper for air flow setting and butterfly valve for regulating fuel output controlled by independent stepper motor actuators
- Starting motor at 2800 rpm, three-phase 400V with neutral, 50Hz (single-phase, 230V and 50Hz for the 45/E C05 model)
- Low emission combustion head, that can be set on the basis of required output, fitted with:
 - stainless steel end cone, resistant to corrosion and high temperatures
 - ignition electrodes
 - ionisation probe
 - gas distributor
 - flame stability disk
- Maximum gas pressure switch to stop the burner in the case of excess pressure on the fuel supply line (on RS 55-68-120-160-200/E-EV BLU models)
- Minimum air pressure switch stops the burner in case of insufficient air quantity at the combustion head
- Burner on/off selection switch
- Flame inspection window
- Slide bars for easier installation and maintenance
- Protection filter against radio interference
- IP 44 electric protection level.

Standard equipment:

- 1 gas train flange
- 1 flange gasket
- 4 screws for fixing the flange
- 1 thermal screen
- 4 screws for fixing the burner flange to the boiler
- Wiring loom fittings for the electrical connection (for RS 45/E C05 model)
- 2 slide bar extensions (for extended head models and RS 160/E-EV - 200/E-EV BLU)
- Pressure switch for valve proofing system (RS 120-160-200/E-EV BLU models)
- Instruction handbook for installation, use and maintenance
- Spare parts catalogue.

Low NOx Modulating Gas Burners

RS 25÷200/E-/EV BLU SERIES

Available models

Burners

CODE	MODEL				HEAT OUTPUT		TOTAL ELECTRICAL POWER (kW)	CERTIFICATION	NOTE
					NATURAL GAS (kW)	(Nm ³ /h)			
3910710	RS 25/E BLU	TC FS1	1/220-230/50-60	220-230/50-60	44/125÷370	4,5/13÷37	0,6	CE 0085BS0379	(1)(3)
3910711	RS 25/E BLU	TL FS1	1/220-230/50-60	220-230/50-60	44/125÷370	4,5/13÷37	0,6	CE 0085BS0379	(1)(3)
20159211	RS 25/E C05	TC FS1	1/220-230/50-60	220-230/50-60	70/125÷340	4,5/12,5÷34	0,6	CE-0123CT1607	(1)(3)
20159212	RS 25/E C05	TL FS1	1/220-230/50-60	220-230/50-60	70/125÷340	4,5/12,5÷34	0,6	CE-0123CT1607	(1)(3)
3910810	RS 35/E BLU	TC FS1	1/220-230/50-60	220-230/50-60	70/200÷480	7/20÷48	0,7	CE 0085BS0379	(1)(3)
3910811	RS 35/E BLU	TL FS1	1/220-230/50-60	220-230/50-60	70/200÷480	7/20÷48	0,7	CE 0085BS0379	(1)(3)
20159213	RS 35/E C05	TC FS1	1/220-230/50-60	220-230/50-60	82/200÷440	7/20÷48	0,7	CE-0123CT1607	(1)
20159214	RS 35/E C05	TL FS1	1/220-230/50-60	220-230/50-60	82/200÷440	7/20÷48	0,7	CE-0123CT1607	(1)
20159218*	RS 45/E C05	TC FS1	1/230/50	230/50-60	90/190-550	9/19-55	0,7	CE 0085BS0380	(1)(3)
20159219*	RS 45/E C05	TL FS1	1/230/50	230/50-60	90/190-550	9/19-55	0,7	CE 0085BS0380	(1)(3)
20038491	RS 55/E BLU	TC FS1	3/230-400/50	230/50-60	100/300-680	10/30-68	1,5	CE 0085CM0293	(1)(3)
20038492	RS 55/E BLU	TL FS1	3/230-400/50	230/50-60	100/300-680	10/30-68	1,5	CE 0085CM0293	(1)(3)
3897432	RS 68/E BLU	TC FS1	3/230-400/50	230/50-60	150/350-860	15/35-86	2,0	CE 0085BS0267	(2)(3)
3897433	RS 68/E BLU	TL FS1	3/230-400/50	230/50-60	150/350-860	15/35-86	2,0	CE 0085BS0267	(2)(3)
3897632	RS 120/E BLU	TC FS1	3/230-400/50	230/50-60	300/600-1300	30/60-130	2,8	CE 0085BS0268	(2)(4)
3897633	RS 120/E BLU	TL FS1	3/230-400/50	230/50-60	300/600-1300	30/60-130	2,8	CE 0085BS0268	(2)(4)
3788032	RS 160/E BLU	TC FS1	3/400/50	230/50-60	300/930-1860	30/93-186	5,3	CE 0085BS0266	(2)(4)
3788033	RS 160/E BLU	TL FS1	3/400/50	230/50-60	300/930-1860	30/93-186	5,3	CE 0085BS0266	(2)(4)
3899810	RS 200/E BLU	TC FS1	3/400/50	230/50-60	570/1375-2400	57/138-240	6,5	CE 0085BT0419	(2)(4)
3899811	RS 200/E BLU	TL FS1	3/400/50	230/50-60	570/1375-2400	57/138-240	6,5	CE 0085BT0419	(2)(4)
3899840	RS 200/E BLU	TC FS1	3/230/50	230/50-60	570/1375-2400	57/138-240	6,5	CE 0085BT0419	(2)(4)
20013995	RS 68/EV BLU	TC FS1/FS2	3/230-400/50	230/50-60	150/350-860	15/35-86	2,0	CE 0085BS0267	(2)(3)(6)
20010976	RS 120/EV BLU	TC FS1/FS2	3/230-400/50	230/50-60	300/600-1300	30/60-130	2,8	CE 0085BS0268	(2)(4)(6)
20014609	RS 120/EV BLU	TL FS1/FS2	3/230-400/50	230/50-60	300/600-1300	30/60-130	2,8	CE 0085BS0268	(2)(4)(6)
(7)	RS 120/EV BLU	TC FS1/FS2	3/230-400/50	230/50-60	300/600-1300	30/60-130	2,8	-	(2)(4)(5)
(7)	RS 160/EV BLU	TC FS1/FS2	3/400/50	230/50-60	300/930-1860	30/93-186	5,3	-	(2)(4)(5)
(7)	RS 160/EV BLU	TL FS1/FS2	3/400/50	230/50-60	300/930-1860	30/93-186	5,3	-	(2)(4)(5)
20010988	RS 160/EV BLU	TC FS1/FS2	3/400/50	230/50-60	300/930-1860	30/93-186	5,3	CE 0085BS0266	(2)(4)(6)
(7)	RS 200/EV BLU	TC FS1/FS2	3/400/50	230/50-60	570/1375-2400	57/138-240	6,5	-	(2)(4)(5)
(7)	RS 200/EV BLU	TL FS1/FS2	3/400/50	230/50-60	570/1375-2400	57/138-240	6,5	-	(2)(4)(5)
20006982	RS 200/EV BLU	TC FS1/FS2	3/400/50	230/50-60	570/1375-2400	57/138-240	6,5	CE 0085BT0419	(2)(4)(6)

Natural gas, net calorific value: 10 kWh/Nm³ - Density: 0,71 kg/Nm³

The burners of RS/E BLU series are in according to 2016/426/EU - 2014/30/EU - 2014/35/EU - 2006/42 EC Directive and EN 676.

(1) With plug and socket.

(2) With terminal board.

(3) Seal control function is included on Burner Digital Management System; it is necessary to add the PVP kit on the gas train as Accessory (see Gas Train Accessories paragraph).

(4) Seal control function is included on Burner Digital Management System; it is necessary to add the PVP kit (included as burner standard equipment) on the gas train.

(5) Frequency Inverter installed on burner motor.

(6) Frequency Inverter to be ordered as separated accessory; please refer to "Burner Accessories" paragraph.

(7) On demand.

* RS 45/E C05 codes listed above will be actually available for orders progressively during year 2019. In the meanwhile, the RS 45/E BLU old codes will remain active as temporary substitutes. The table below shows the correspondence:

RS 25÷200/E-/EV BLU SERIES

Available models

Burners

* RS 45/E C05 codes listed above will be actually available for orders progressively during year 2019. In the meanwhile, the RS 45/E BLU old codes will remain active as temporary substitutes. The table below shows the correspondence:

MODEL	RS 45/E C05 (NEW)	RS 45/E BLU (OLD)
▶ TC FS1 1/230/50 230/50-60	20159218	3897332
▶ TL FS1 1/230/50 230/50-60	20159219	3897333

Gas Trains

CODE	GAS TRAIN MODEL	Ø	ADAPTER CODE							
			RS 25	RS 35-45	RS 55	RS 68	RS 120	RS 160	RS 200	
3970599*	MB 407/1 - RT 52	Rp 3/4"	3000824		3000824 + 3000843		●	●	●	●
3970258*	MB 410/1 - RT 52	Rp 1" 1/4	3010124		3010126			●	●	
3970600*	MB 410/1 - RT 52	Rp 3/4"	3000824		3000824 + 3000843			●	●	
3970256*	MB 412/1 - RT 52	Rp 1" 1/2	□	□	3000843					●
3970250*	MB 415/1 - RT 52	Rp 1" 1/2	□		3000843					
3970257*	MB 420/1 - RT 52	Rp 2"	3000822		□					
3970221*	MBC 1200/1 - RSM 60	Rp 2"	□		3000825					
3970222*	MBC 1900/1 - FSM 40	DN 65	●		3000826					
3970223*	MBC 3100/1 - FSM 40	DN 80	●		●					
3970224*	MBC 5000/1 - FSM 80	DN 100	●		●	●	●	●		3010370 + 3000826
3970145*	CB 512/1 - RSM 30	Rp 1" 1/2	□		3000843					
3970146*	CB 520/1 - RSM 30	Rp 2"	3000822		□					
20044659*	CB 525/1 - RSM 30	Rp 2"	□		□					
3970147*	CB 5065/1 - FSM 30	DN 65	●		3000825					
3970148*	CB 5080/1 - FSM 30	DN 80	●	●	3000826					
3970149*	CB 50100/1 - FSM 30	DN 100	●	●	●					3010370 + 3000826
20015871*	CB 50125/1 - FSM 30	DN 125	●	●	●	●				3010224 + 3000826

Please see designation of Gas Train Series in the page before the Catalogue index.

* 230V/50Hz - 220V/60Hz electrical supply.

The valves seal control device is compulsory (conforming to EN 676) on gas trains to burners with a maximum output over 1200 kW.

The seal control function is managed by REC control box, by installation on gas train of a pressure switch (please see Gas train accessories paragraph); it is included as standard equipment on RS 120/E-EV-160/E-EV-200/E-EV BLU models.

To select the gas train please refer to the technical data leaflet and/or instruction manual.

● Not available.

□ Additional adapter not necessary, the gas train may be connected directly to the burner.

Low NOx Modulating Gas Burners

RS 25÷200/E-/EV BLU SERIES

Burner accessories

All RS 25-35-45/E BLU accessories listed below are available also for the correspondent RS/E C05 models.

Extended head kit

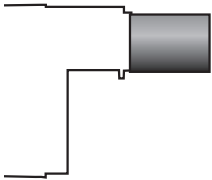

“Standard head” burners can be transformed into “extended head” versions, by using the special kit. The KITS available for the various burners, giving the original and the extended lengths, are listed below.

BURNER	STANDARD HEAD LENGTH (mm)	EXTENDED HEAD LENGTH (mm)	KIT CODE
▶ RS 25/E BLU – C05	230	365	3010430
▶ RS 35/E BLU – C05	230	365	3010431
▶ RS 45/E C05	229	354	20006586
▶ RS 55/E BLU	255	390	20040373
▶ RS 68/E-EV – 120/E-EV BLU	255	390	3010177
▶ RS 160/E-EV BLU	373	503	3010442
▶ RS 200/E-EV BLU	373	503	3010474

Spacer kit

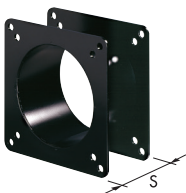

If burner head penetration into the combustion chamber needs reducing, varying thickness spacers are available, as given in the following list.

BURNER	SPACER THICKNESS S (mm)	KIT CODE
▶ RS 25/E – 35/E BLU – C05 – RS 45/E C05	110	3010095
▶ RS 55/E – 68/E-EV – 120/E-EV BLU	135	3010129
▶ RS 160/E-EV – 200/E-EV BLU	102	3000722

Continuous ventilation kit



If the burner requires continuous ventilation in the stages without flame, a special kit is available as given in the following table.

BURNER	KIT CODE
▶ RS 25/E – 35/E BLU – C05	3010449
▶ RS 45/E C05 – RS 55/E – 68/E-EV – 120/E-EV – 160/E-EV – 200/E-EV BLU	3010094

Note: the Post-ventilation function is obtainable by modification of the Digital Burner Management System parameters (see burner instruction manual).

Sound proofing box

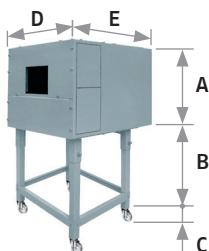

If noise emission needs reducing even further, sound-proofing boxes are available. When a lower “B” dimension is required, it is available the Box Support Kit code 20065135 which allows to reduce it at the fixed dimension of 55 mm. The sound-proofing boxes are not suitable for outdoor use.

BURNER	BOX TYPE	A (mm)	B (mm) min-max	C (mm)	D (mm)	E (mm)	[dB(A)] (*)	BOX CODE
▶ RS 25/E – 35/E BLU – C05 ▶ RS 45/E C05 – RS 55/E BLU	C1/3	650	372 – 980	110	690	770	10	3010403
▶ RS 68/E-EV – 120/E-EV BLU ▶ RS 160/E-EV – 200/E-EV BLU	C4/5	850	160 – 980	110	980	930	10	3010404

(*) Average noise reduction according to EN 15036-1 standard

RS 25÷200/E-/EV BLU SERIES

Burner accessories

Accessories for modulating operation



To obtain modulating operation, the RS/E BLU series of burners requires a regulator with three point outlet controls. On RS 25/E - 35/E BLU the regulator is connected to the burner electrical wiring by plug-in system in order to make the connection easier and faster.

The following table lists the accessories for modulating operation with their application range.

For remote setpoint use RWF 55.

BURNER	REGULATOR TYPE	REGULATOR CODE
▶ RS 25/E - 35/E - 45/E C05 - RS 55/E BLU	RWF 50.2	20083339
	RWF 55.5	20098541
▶ RS 68/E-EV - 120/E-EV - 160/E-EV - 200/E-EV BLU	RWF 50.2	20099869
	RWF 55.5	20099905



The relative temperature or pressure probes fitted to the regulator, must be chosen on the basis of the application.

BURNER	PROBE TYPE	RANGE (°C) (bar)	PROBE CODE
▶ All models	Temperature PT 100	-100 ÷ 500°C	3010110
	Pressure 4 ÷ 20 mA	0 ÷ 2,5 bar	3010213
	Pressure 4 ÷ 20 mA	0 ÷ 16 bar	3010214
	Pressure 4 ÷ 20 mA	0 ÷ 25 bar	3090873

Head kit for “reverse flame chamber”



In certain cases, the use of the burner on reverse flame boilers can be improved by using an additional Pipes Kit.

BURNER	KIT CODE (*)
▶ RS 68/E-EV BLU	3010247
▶ RS 120/E-EV BLU	3010248
▶ RS 160/E-EV BLU	3010249
▶ RS 200/E-EV BLU	20035848

(*) CE approval on field is required

Ground fault interrupter kit



A “Ground fault interrupter kit” is available as a safety device in case of electrical system fault.

BURNER	KIT CODE
▶ RS 25/E - 35/E BLU - C05	3010448
▶ RS 45/E C05 - RS 55/E BLU	20098335
▶ RS 68/E-/EV - 120/E-/EV - 160/E-/EV - 200/E-/EV BLU	20098337

Low NOx Modulating Gas Burners

RS 25÷200/E-/EV BLU SERIES

Burner accessories

Gas max pressure switch

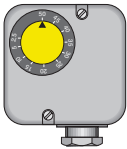

If necessary a Gas max pressure Switch kit is available and connectable to the burner electrical wiring trough Plugs & Sockets system.

BURNER	CODE
▶ RS 25/E - 35/E BLU - C05	3010418

Volt free contact kit



A volt free contact kit is available for installation onto the burner. It can be used for a remote interface between burner operating signals. Every burner can be equipped with a single kit for a remote check of the flame presence signal and the burner lock-out indication.

BURNER	KIT CODE
▶ RS 25/E - 35/E BLU - C05	3010419

LPG kit

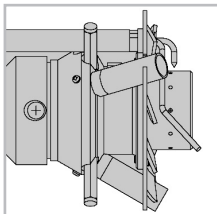

For burning LPG gas, a special kit is available to be fitted to the combustion head on the burner, as given in the following table:

BURNER	KIT CODE FOR 'STANDARD HEAD'	KIT CODE FOR 'EXTENDED HEAD'
▶ RS 25/E BLU - C05	3010423	3010423
▶ RS 35/E BLU - C05	3010424	3010424
▶ RS 45/E C05	(1)	(1)
▶ RS 55-68-120-160-200/E BLU		
▶ RS 200/E-EV BLU	3010491	3010491

(1) Not available

PC Interface kit



To connect the control box to a personal computer for the transmission of operation, fault signals and detailed service information, an interface adapter with PC software are available.

BURNER	KIT CODE
▶ All models	3010436

OCI412 interface kit



Interface kit between the REC27.100A2 and a Modbus system, such as a building automation and control system (BACS). The Modbus interface is based on the RS-485 standard.

BURNER	KIT CODE
▶ All models	3010437

RS 25÷200/E-/EV BLU SERIES

Burner accessories

DN80 gas flange kit

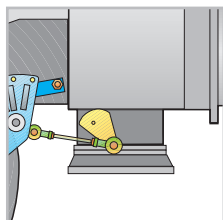

To modify the standard 2" burner gas input connection in to DN80 connection, a specific gas flange is available.

BURNER	KIT CODE
▶ RS 68/E-EV - 120/E-EV - 160/E-EV - 200/E-EV BLU	3010439

Variable Speed Drive (VSD) for RS/EV series only













The motor speed variation for the RS/EV BLU burners series is obtained thanks to a frequency converter: variable speed drive (VSD), provided with a programming panel with start-up assistant. It always must be ordered with RS/EV series.

BURNER	MAX POWER (kW)	KIT CODE
▶ RS 68/EV BLU	1,5	20163060
▶ RS 120/EV BLU	3,0	20163064
▶ RS 160/EV - 200/EV BLU	5,5	20163071

Gas train accessories

Adapters

When the diameter of the gas train is different from the set diameter of the burners, an adapter must be fitted between the gas train and the burner. Below are given the available adapters; please see on the Gas Train list the correct adapter codes to select.

ADAPTER	LENGTH mm	ADAPTER CODE
2"  1" 1/2	70	3000822
3/4"  1" 1/2	31	3000824
2" 1/2  2"	300	3000825
DN 65  2" 1/2  1" 1/2		
DN 80  2" 1/2  2"	300	3000826
1" 1/2  2"	35	3000843
1" 1/4  1" 1/2	35	3010124
1" 1/4  2"	35	3010126

Low NOx Modulating Gas Burners

RS 25÷200/E-/EV BLU SERIES

Gas train accessories

PVP (Pressure Valve Proving) kit *

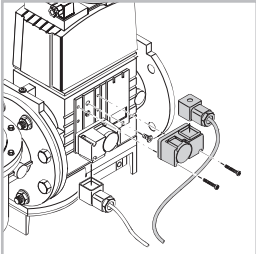

The seal control function is included on Burner Digital Management System, it is only necessary to add the PVP kit on the gas train. The PVP is included as standard equipment on RS 120/E-EV-160/E-EV-200/E-EV BLU models.

BURNER	KIT CODE
► MB - MBC - CB type	3010344

* not necessary for the RS 120/E-EV - 160/E-EV - 200/E-EV BLU models where is included as a standard.

Stabiliser spring



Accessory springs are available to vary the pressure range of the gas train composed. The following table shows these accessories with their application range. Please refer to the technical manual for the correct choice of spring.

GAS TRAIN	SPRING COLOUR	SPRING PRESSURE RANGE mbar	SPRING CODE
► MBC 1900/1 - 3100/1	White	4 - 20	3010381
	Red	20 - 40	3010382
	Black	40 - 80	3010383
	Green	80 - 150	3010384
► CB 512/1	Red	25 - 55	3010131
	Black	60 - 110	3010157
	Pink	90 - 150	3090486
► CB 520/1 - 525/1	Red	25 - 55	3010132
	Black	60 - 110	3010158
	Pink	100 - 150	3090487
► CB 5065/1 - 5080/1	Red	25 - 55	3010133
	Black	60 - 110	3010135
	Pink	100 - 150	3090456
	Grey	140 - 200	3090992

RS 310-410-510-610-810/M BLU SERIES

The RS 310-410-510-610-810/M BLU burners series covers a firing range from 1200 to 6250 kW, and it has been designed for use in low or medium temperature hot water boilers, hot air or steam boilers, diathermic oil boilers.

Operation can be "two stage progressive" or, alternatively, "modulating" with the installation of a PID logic regulator or by external 4-20 mA/0-10 V signal.

The mechanical cam device of regulation allows to catch up a high modulation ratio on all firing rates range. The burners can, therefore, supply with precision the demanded power, guaranteeing a high efficiency system level and the stability setting, obtaining fuel consumption and operating costs reduction.

The combustion head, engineered with advanced simulation devices, guarantees reduced polluting emissions.

FS1 and FS2 versions are available for intermittent and continuous operation applications.

The exclusive design ensures reduced dimensions, simple use and maintenance.

A wide range of accessories guarantees elevated working flexibility.

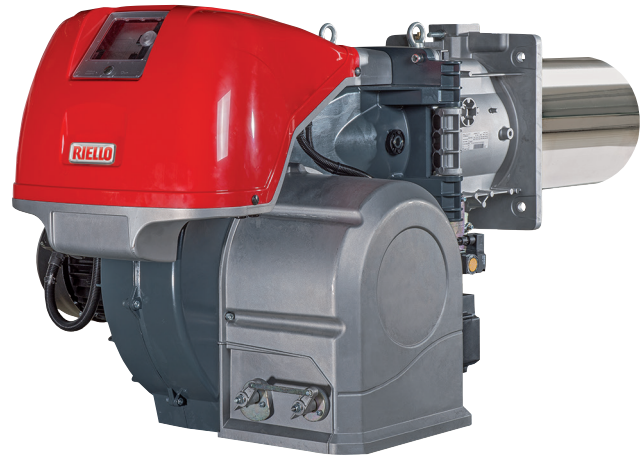

RS 310/M BLU	400/1200 ÷ 3630	kW
RS 410/M BLU	500/1500 ÷ 4450	kW
RS 510/M BLU	680/1800 ÷ 5250	kW
RS 610/M BLU	1000/2200 ÷ 6250	kW
RS 810/M BLU	1200/3500 ÷ 8010	kW

FIRING RATES

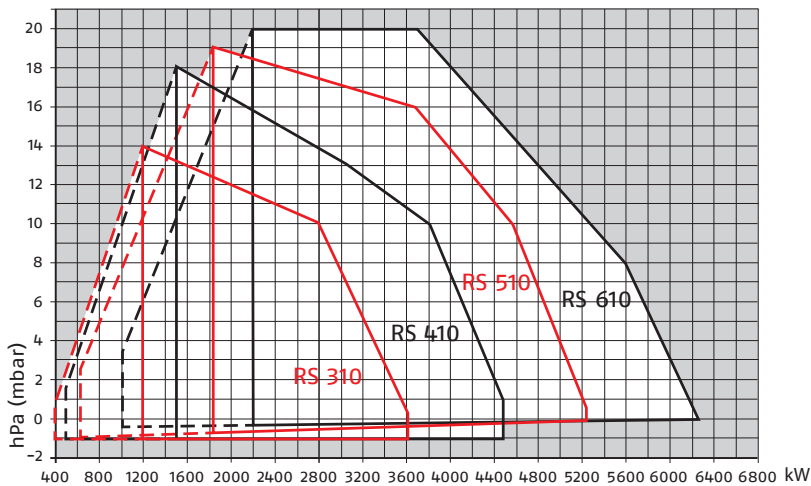

Useful working field for choosing the burner



Modulation range

Test conditions conforming to EN676
 Temperature: 20°C
 Pressure: 1013,5 mbar
 Altitude: 0 m a.s.l.

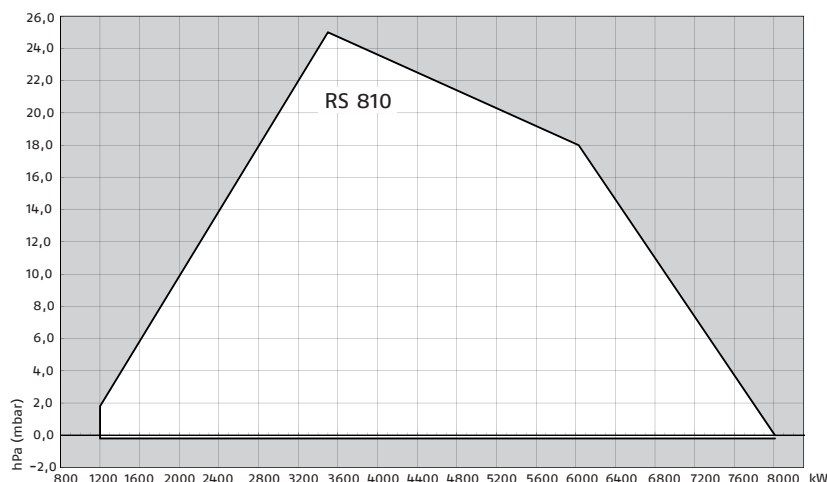

Low NOx Modulating Gas Burners

RS 310-410-510-610-810/M BLU SERIES

Overall dimensions (mm)

BURNER

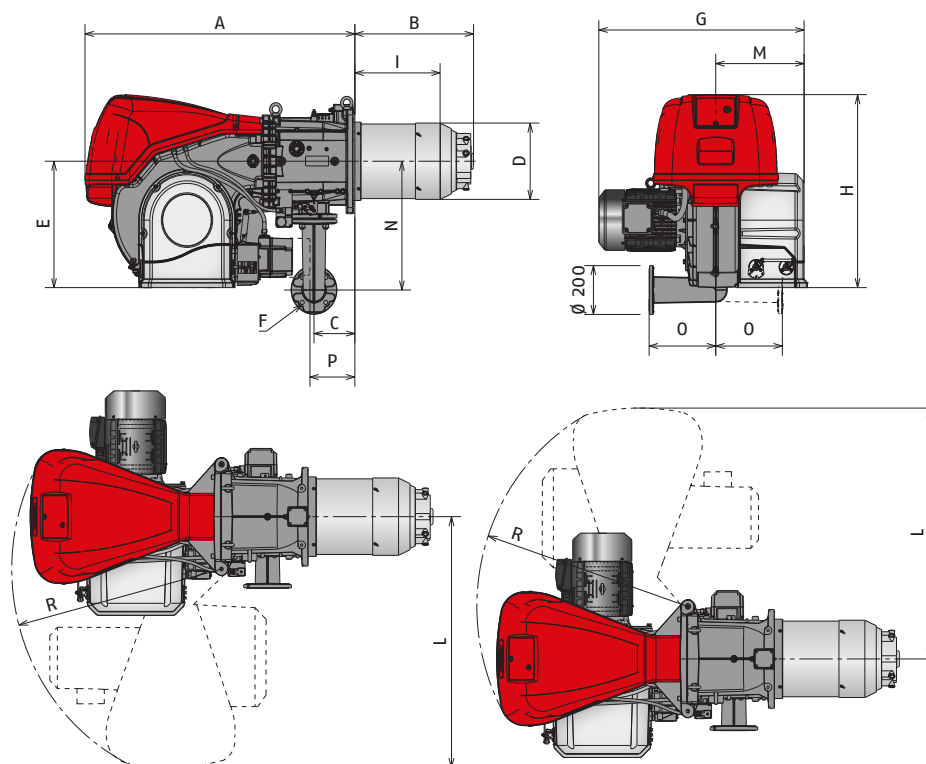

Model	A	B	C	D	E	F	G	H	I	L	M	N	O	P*	R
▶ RS 310/M BLU	1178	465	178	306	520	DN65	890	790	346	1015	400	528	290	177	890
▶ RS 410/M BLU	1178	517	178	313	520	DN65	908	790	365	930	400	528	290	177	890
▶ RS 510/M BLU	1178	517	178	313	520	DN65	908	790	365	930	400	528	290	177	890
▶ RS 610/M BLU	1178	517	178	334	520	DN65	980	790	360	1015	400	528	290	177	890
▶ RS 810/M BLU	1345	558	173	336	585	DN80	980	790	405	1197	413	528	290	177	1055

* Maximum position for the extraction of the servomotor cover in mechanical cam models.

BURNER - BOILER MOUNTING FLANGE

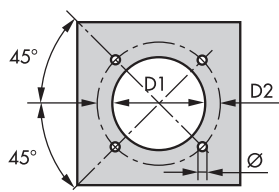

MODEL	D1	D2	Ø
▶ RS 310/M BLU	335	452	M18
▶ RS 410/M BLU	335	452	M18
▶ RS 510/M BLU	335	452	M18
▶ RS 610/M BLU	350	452	M18
▶ RS 810/M BLU	400	495	M18

PACKAGING

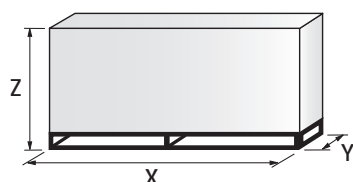

MODEL	X	Y	Z	kg
▶ RS 310/M BLU	2040	1180	1125	250
▶ RS 410/M BLU	2040	1180	1125	250
▶ RS 510/M BLU	2040	1180	1125	250
▶ RS 610/M BLU	2040	1180	1125	280
▶ RS 810/M BLU	2190	1110	1446	300

Low NOx Modulating Gas Burners

RS 310-410-510-610-810/M BLU SERIES

RIELLO

Specification

DESIGNATION OF SERIES

A specific index guides your choice of burner from the various models available in the RS/M BLU series. Below is a clear and detailed specification description of the product.

Series: R										
Fuel: S Natural Gas										
L Light oil										
LS Light oil/Natural Gas										
N Heavy oil										
Size:										
Setting: /1 Single stage										
/B Two stage										
/M Modulating-Mechanical cam										
/E Electronic cam										
/P Proportioning air/gas valve										
/EV Electronic cam predisposed for variable speed (with inverter)										
/EVi Electronic cam with integrated inverter										
Emission: ... or CO1 Class 1 EN676										
MZ Class 2 EN676										
BLU Class 3 EN676										
MX Class 3 EN676										
Head length: TC standard head										
TL extended head										
Flame control system: FS1 Standard/Intermittent (at least 1 stop every 24 h)										
FS2 Continuous (1 stop every 72 h)										
Electrical supply to the system:										
1/230/50					1/230V/50Hz					
3/230/50					3/230V/50Hz					
3/400/50					3N/400V/50Hz					
3/230-400/50					3/230V/50Hz - 3N/400V/50Hz					
3/220/60					3/220V/60Hz					
3/380/60					3N/380V/60Hz					
3/220-380/60					3/220/60Hz - 3N/380V/60Hz					
Auxiliary voltage: 230/50-60 230V/50-60H										
110/50-60 110V/50-60Hz										
R	S	510	/M	BLU	TC	FS1	3/230-400/50	230/50-60		
BASIC DESIGNATION							EXTENDED DESIGNATION			

LOW NOx GAS

Low NOx Modulating Gas Burners

RS 310-410-510-610-810/M BLU SERIES

Specification

STATE OF SUPPLY

Monoblock forced draught gas burners with modulating operation, fully automatic, made up of:

- High performance fan with low sound emissions, forward curve blades.
- Air suction circuit lined with sound-proofing material
- Air damper for air setting controlled by a high precision servomotor
- Air pressure switch
- Fan starting motor at 2900 rpm, three-phase 230/400 - 400/690 V with neutral, 50 Hz
- Combustion head, that can be set on the basis of required output, fitted with:
 - stainless steel end cone, resistant to corrosion and high temperatures
 - ignition electrodes; ionisation sensor for flame detection
 - flame stability disk
- Maximum gas pressure switch, with pressure test point, for halting the burner in the case of over pressure on the fuel supply line
- Burner safety control box for controlling the system safety: RMG/M for FS1 intermittent operation and RFG0 for both FS1 intermittent operation and FS2 continuous operation (with ionization probe only);
- Star/delta starter for the fan motor (Direct starter fan motor for RS 310-410 models)
- Main electrical supply terminal board
- Burner on/off switch
- Manual or automatic output increase/decrease switch
- Contacts motor and thermal relay with release button
- Burner failure led signal and lighted release button
- Burner opening hinge
- Lifting rings
- IP 54 electric protection level

Standard equipment:

Gasket for gas train adaptor

Adaptor for gas train

Screws for fixing the gas train adaptor: M 16 x 70

Thermal insulation screen

M 18 x 60 screws to secure the burner flange to the boiler

Cable grommets kit for optional electrical wiring input

M16 x 6 studs for fixing the gas elbow to the pipe coupling

M16 nuts to fix the gas elbow to the pipe coupling

Instruction handbook for installation, use and maintenance

Spare parts catalogue

Gas train

Fuel supply line, in the MULTIBLOC configuration (for a diameter of 1-1/2" and 2") or COMPOSED configuration (from a diameter of DN 65 until a diameter of DN 125), fitted with:

- Filter
- Stabiliser
- Minimum gas pressure switch
- Safety valve
- One stage working valve with ignition gas output regulator.

Specification

Conforming to:

- 2014/30/EU directive (electromagnetic compatibility)
- 2014/35/EU directive (low voltage)
- 2016/426/EU gas regulation (GAR)
- 2006/42 EC directive (machine)
- 2014/68/EU Pressure Equipment Directive
- EN 676 (gas burners).

Available accessories to be ordered separately:

- Power controller
- Probe
- Analog control signal converter
- Potentiometer
- Continuous ventilation kit
- PC interface kit
- Sound proofing box
- Spacer kit
- Adapters
- Seal Control kit
- Stabiliser spring.

Low NOx Modulating Gas Burners

RS 310-410-510-610-810/M BLU SERIES

Available models

Burners

CODE	MODEL				HEAT OUTPUT		TOTAL ELECTRICAL POWER (KW)	CERTIFICATION	NOTE
					NATURAL GAS				
					(KW)	(Nm ³ /h)			
20067964	RS 310/M BLU	TC	FS1	3/400/50	400/1200-3630	40/120-363	8,8	CE-0085CP0166	(1) (4)
20068219	RS 310/M BLU	TC	FS1	3/230/50	400/1200-3630	40/120-363	9,1	CE-0085CP0166	(1)
20068245	RS 310/M BLU	TC	FS1	3/400/50	400/1200-3630	40/120-363	9,1	CE-0085CP0166	(1)
20152646	RS 310/M BLU	TC	FS1/FS2	3/400/50	400/1200-3630	40/120-363	9,1	CE-0085CP0166	(2) (3) (4)
20152634	RS 310/M BLU	TC	FS1/FS2	3/230/50	400/1200-3630	40/120-363	9,1	CE-0085CP0166	(2) (3)
20152636	RS 310/M BLU	TC	FS1/FS2	3/400/50	400/1200-3630	40/120-363	9,1	CE-0085CP0166	(2) (3)
20069841	RS 410/M BLU	TC	FS1	3/400/50	500/1500-4450	50/150-445	10,6	CE-0085CP0166	(1) (4)
20068270	RS 410/M BLU	TC	FS1	3/230/50	500/1500-4450	50/150-445	10,8	CE-0085CP0166	(1)
20068284	RS 410/M BLU	TC	FS1	3/400/50	500/1500-4450	50/150-445	10,8	CE-0085CP0166	(1)
20152650	RS 410/M BLU	TC	FS1/FS2	3/400/50	500/1500-4450	50/150-445	10,8	CE-0085CP0166	(2) (3) (4)
20152640	RS 410/M BLU	TC	FS1/FS2	3/230/50	500/1500-4450	50/150-445	10,8	CE-0085CP0166	(2) (3)
20152643	RS 410/M BLU	TC	FS1/FS2	3/400/50	500/1500-4450	50/150-445	10,8	CE-0085CP0166	(2) (3)
20069845	RS 510/M BLU	TC	FS1	3/400/50	680/1800-5250	68/180-525	14	CE-0085CP0166	(1) (4)
20152653	RS 510/M BLU	TC	FS1/FS2	3/400/50	680/1800-5250	68/180-525	14	CE-0085CP0166	(2) (3) (4)
20069847	RS 610/M BLU	TC	FS1	3/400/50	1000/2200-6250	100/220-625	16,9	CE-0085CP0166	(1) (4)
20152657	RS 610/M BLU	TC	FS1/FS2	3/400/50	1000/2200-6250	100/220-625	16,9	CE-0085CP0166	(2) (3) (4)
20155846	RS 810/M BLU	TC	FS1	3/400/50	1200/3500-8010	120/350-801	24.5	CE-0123CU1067	(1) (4)
20155875	RS 810/M BLU	TC	FS1/FS2	3/400/50	1200/3500-8010	120/350-801	24.5	CE-0123CU1067	(2) (3) (4)

Natural gas, net calorific value: 10 kWh/Nm³ - Density: 0,71 kg/Nm³

The burners of RS/M BLU series are in according to 2016/426/EU - 2014/30/EU - 2014/35/EU - 2014/68/UE - 2006/42 EC Directives.

- (1) with RMG/M control box
- (2) with RFG0 control box
- (3) FS2 operation is allowed with ionization probe only, no other flame sensors can be used.
- (4) Star delta starter

Due to the improvement applied on the technical specification of some products, some burner codes will change during year 2019. The table below summarizes the correspondence between the previous and the new code.

MODEL				NEW CODE		OLD CODE
RS 310/M BLU	TC	FS1/FS2	3/230/50	20152634	(2) (3)	20074121
RS 310/M BLU	TC	FS1/FS2	3/400/50	20152636	(2) (3)	20074122
RS 310/M BLU	TC	FS1/FS2	3/400/50	20152646	(2) (3)	20074125
RS 410/M BLU	TC	FS1/FS2	3/230/50	20152640	(2) (3)	20074123
RS 410/M BLU	TC	FS1/FS2	3/400/50	20152643	(2) (3)	20074124
RS 410/M BLU	TC	FS1/FS2	3/400/50	20152650	(2) (3)	20074126
RS 510/M BLU	TC	FS1/FS2	3/400/50	20152653	(2) (3)	20074127
RS 610/M BLU	TC	FS1/FS2	3/400/50	20152657	(2) (3)	20074128
RS 810/M BLU	TC	FS1/FS2	3/400/50	20155875	(2) (3)	NA

Low NOx Modulating Gas Burners

RS 310-410-510-610-810/M BLU SERIES

RIELLO

Available models

Gas Trains

CODE	GAS TRAIN			VPS Code	ADAPTER CODE				
	MODEL	Ø	C.T.		RS 310	RS 410	RS 510	RS 610	RS 810
3970180*	MB 415/1 - RT 30	Rp 1" 1/2	-	3010123	3000826 + 20064220	●	●	●	●
3970198**	MB 415/1 CT RT 30	Rp 1" 1/2	◆	-		●	●	●	●
3970250*	MB 415/1 - RT 52	Rp 1" 1/2	-	3010123		●	●	●	●
3970253**	MB 415/1 CT RT 52	Rp 1" 1/2	◆	-		●	●	●	●
3970232*	MB 415/1 - RSM 30	Rp 1" 1/2	-	3010123	3000826 + 20042324	●	●	●	●
3970181*	MB 420/1 - RT 30	Rp 2"	-	3010123		●	●	●	●
3970182**	MB 420/1 CT RT 30	Rp 2"	◆	-		●	●	●	●
3970257*	MB 420/1 - RT 52	Rp 2"	-	3010123		●	●	●	●
3970252**	MB 420/1 CT RT 52	Rp 2"	◆	-	3000826 + 20042324	●	●	●	●
3970233*	MB 420/1 - RSM 30	Rp 2"	-	3010123		●	●	●	●
3970234**	MB 420/1 CT RSM 30	Rp 2"	◆	-		●	●	●	●
3970221*	MBC 1200/1 - RSM 60	Rp 2"	-	3010123		3000826 + 20042324			20042324 + 20064169/ (20068062) (1)
3970225**	MBC 1200/1 CT RSM 60	Rp 2"	◆	-	3010221			20059330/ (20065924 + 20059330)(1) / (3010221 + 20059331) (2)	
3970222*	MBC 1900/1 - FSM 40	DN 65	-	3010123	3010222			20059331/ (20065937+20059331) (1) / (3010222 + 20059331) (2)	
3970226**	MBC 1900/1 CT FSM 40	DN 65	◆	-	3010222 - 3010370			20059332/ (20065960 + 20059332) (1) / (3010223 + 20059331) (2)	
3970223*	MBC 3100/1 - FSM 40	DN 80	-	3010123	3010223			20059331/ (20065960 + 20059332) (1) / (3010223 + 20059331) (2)	
3970227**	MBC 3100/1 CT FSM 40	DN 80	◆	-	3010223			20059331/ (20065960 + 20059332) (1) / (3010223 + 20059331) (2)	
3970224*	MBC 5000/1 - FSM 80	DN 100	-	3010123	3010222 - 3010370			20059332/ (20065960 + 20059332) (1) / (3010223 + 20059331) (2)	
3970228**	MBC 5000/1 CT FSM 80	DN 100	◆	-	3010222 - 3010370			20059332/ (20065960 + 20059332) (1) / (3010223 + 20059331) (2)	
3970145*	CB 512/1 - RSM 30	Rp 1" 1/2	-	3010123	3000826 + 20064220	●	●	●	
20045589**	CB 512/1 CT RSM 30	Rp 1" 1/2	◆	-		●	●	●	
3970146*	CB 520/1 - RSM 30	Rp 2"	-	3010123	3000826 + 20042324	●	●	●	
3970160**	CB 520/1 CT RSM 30	Rp 2"	◆	-		●	●	●	
20044659*	CB 525/1 - RSM 30	Rp 2"	-	3010123	3000826 + 20042324	●	●	●	
20044660**	CB 525/1 CT RSM 30	Rp 2"	◆	-		●	●	●	
3970147*	CB 5065/1 - FSM 30	DN 65	-	3010123	3010221			20059330/ (20065924 + 20059330) (1) / (3010221 + 20059331) (2)	
3970161**	CB 5065/1 CT FSM 30	DN 65	◆	-	3010221			20059330/ (20065924 + 20059330) (1) / (3010221 + 20059331) (2)	
3970148*	CB 5080/1 - FSM 30	DN 80	-	3010123	3010222			20059331/ (20065937+20059331) (1) / (3010222 + 20059331) (2)	
3970162**	CB 5080/1 CT FSM 30	DN 80	◆	-	3010222			20059331/ (20065937+20059331) (1) / (3010222 + 20059331) (2)	
3970149*	CB 50100/1 - FSM 30	DN 100	-	3010123	3010223 - 3010370			20059332/ (20065960 + 20059332) (1) / (3010223 + 20059331) (2)	
3970163**	CB 50100/1 CT FSM 30	DN 100	◆	-	3010223 - 3010370			20059332/ (20065960 + 20059332) (1) / (3010223 + 20059331) (2)	
20015871*	CB 50125/1 - FSM 30	DN 125	-	3010123	3010224			20059333/ (20065968 + 20059333) (1) / (3010224 + 20059331) (2)	
3970196**	CB 50125/1 CT FSM 30	DN 125	◆	-	3010224			20059333/ (20065968 + 20059333) (1) / (3010224 + 20059331) (2)	

Please see designation of Gas Train Series in the page before the Catalogue index.

* 230V/50Hz - 220V/60Hz electrical supply.

** 230V/50Hz electrical supply.

The valve seal control device is compulsory (conforming to EN 676) on gas trains to burners with a maximum output over 1200 kW.

To select the gas train please refer to the technical data leaflet and/or instruction manual.

C.T. Gas valve leak detection control device:

- gas train not equipped with leak detection control device; this device can be ordered separately - see VPS column - and installed later.

◆ gas train equipped with leak detection control device.

VPS Valve leak detection control device. Supplied separately from the gas train (please see Gas train accessories paragraph for both 50 Hz and 60 Hz codes).

● Not available.

□ Additional adapter not necessary, the gas train may be connected directly to the burner.

1) To be used with gas train and burner opening on the left (fan motor side).

2) To be used with gas train on the left (fan motor side) and burner opening on the right.

Low NOx Modulating Gas Burners

RS 310-410-510-610-810/M BLU SERIES

Burner accessories

Accessories for modulating operation

POWER CONTROLLER



To obtain modulating operation, the RS/M BLU series of burners requires a regulator with three point outlet controls. The following table lists the accessories for modulating operation with their application range. For remote setpoint use RWF 55.

BURNER	TYPE	KIT CODE
▶ All models	RWF 50.2 - Basic version with 3 position output	20073595
	RWF 55.5 - Complete with RS-485 interface	20074441
	RWF 55.6 - Complete with RS-485/ PROFIBUS interface	20074442

PROBE



The relative temperature or pressure probes fitted to the power controller must be chosen on the basis of the application.

BURNER	TYPE	RANGE (°C) (BAR)	KIT CODE
▶ All models	Temperature PT 100	-100 ÷ 500°C	3010110
	Pressure 4 ÷ 20 mA	0 ÷ 2,5 bar	3010213
	Pressure 4 ÷ 20 mA	0 ÷ 16 bar	3010214
	Pressure 4 ÷ 20 mA	0 ÷ 25 bar	3090873

ANALOG CONTROL SIGNAL CONVERTER



BURNER	TYPE (INPUT SIGNAL)	KIT CODE
▶ RS 310-410-510-610-810/M	0/2 - 10 V (impedance 200 KΩ)	20074479
	0/4 - 20 mA (impedance 250 Ω)	

POTENTIOMETER

BURNER	KIT CODE
▶ RS 310-410-510-610-810/M	20074487

Continuous ventilation kit



If the burner requires continuous ventilation in the stages without flame, a special kit is available as given in the following table:

BURNER	KIT CODE
▶ RS 310-410-510-610-810/M	20074542

Low NOx Modulating Gas Burners

RS 310-410-510-610-810/M BLU SERIES

RIELLO

Burner accessories

Pc interface kit



To connect the RMG control panel to a personal computer for the transmission of operation, fault signals and detailed service information, an interface adapter with PC software are available.

BURNER	KIT CODE
▶ RS 310-410-510-610-810/M	3002719

Sound proofing box

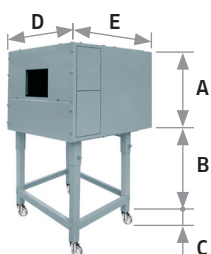

If noise emission needs reducing even further, sound-proofing boxes are available.

When a lower "B" dimension is required, it is available the Box Support Kit code 20065135 which allows to reduce it at the fixed dimension of 55 mm.

The sound-proofing boxes are not suitable for outdoor use.

BURNER	BOX TYPE	A (mm)	B (mm) min. - max	C (mm)	D (mm)	E (mm)	[dB(A)] (*)	KIT CODE
▶ RS 310-410/M	C7	1255	160 - 980	110	1140	1345	10	3010376
▶ RS 610/M	C7 PLUS	1255	270 - 1090	110	1240	1345	10	20085111
▶ RS 310-410M RS510-810/M	C7	1255	165	110	1140	1345	10	20027778

(*) Average noise reduction according to EN 15036-1 standard

Spacer kit

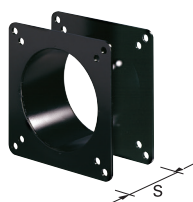

If burner head penetration into the combustion chamber needs reducing, varying thickness spacers are available, as given in the following table:

BURNER	Spacer thickness S (mm)	KIT CODE
▶ All models	180	20008903

Uv Flame sensor



UV90L flame sensor can be used only with the RFG0 control box and when the LFL control box with UV flame sensor type QRA2 must be replaced.

BURNER	KIT CODE
▶ All models (*)	On demand

(*) Only with RFG0 control box.









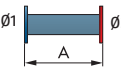
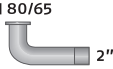

Low NOx Modulating Gas Burners

RS 310-410-510-610-810/M BLU SERIES

Gas train accessories

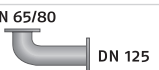
Adapters

In certain cases, an adapter must be fitted between the gas train and the burner, when the diameter of the gas train is different from the set diameter of the burner. Below are given the available adapters; please see on the Gas Train list the correct adapter codes to select.

ADAPTER	DIMENSIONS		ADAPTER CODE		
	Ø1 DN	Ø2 DN		A mm	B mm
 1" 1/2 2"	-	-	65	-	20064220
 2" 2"	-	-	65	-	20042324
 DN 80 2" 1/2 2"	-	-	300	-	3000826
	65	80	400	-	3010221
	80	80	400	-	3010222
	100	80	400	-	3010223
	125	80	320	-	3010224
 DN 80/65 2"			230	-	20064169
 DN 80/65 2"			780	-	20068062
 DN 65/80 DN 65			230	-	20059330
 DN 65/80 DN 80			230	-	20059331
 DN 65/80 DN 100			230	-	20059332
 DN 65/80 DN 125			245	-	20059333
 DN 65 DN 65			800	-	20065924
 DN 80 DN 80			800	-	20065937
 DN 100 DN 100			800	-	20065960
 DN 125 DN 125			800	-	20065968

Low NOx Modulating Gas Burners

RS 310-410-510-610-810/M BLU SERIES

RIELLO

Seal control kit



To test the valve seals on the gas train, a special "seal control kit" is available. The valve seal control device is compulsory (EN 676) on gas trains to burners with a maximum output over 1200 kW. The seal control is type VPS 504.

GAS TRAIN	Kit code for 50 Hz operation
▶ MB type	3010123
▶ MCB - CB - DMV type	3010123

Stabiliser spring



To vary the pressure range of the gas train stabilisers, accessory springs are available. The following table shows these accessories with their application range. Please refer to the technical manual for the correct choice of spring.

GAS TRAIN	SPRING COLOUR	SPRING Pressure range mbar	SPRING CODE
MBC 1900/1 - 3100/1 MBC 5000/1	White	4 - 20	3010381
	Red	20 - 40	3010382
	Black	40 - 80	3010383
CB 512/1	Green	80 - 150	3010384
	Red	25 - 55	3010131
	Black	60 - 110	3010157
CB 520/1 - 525/1	Pink	90 - 150	3090486
	Red	25 - 55	3010132
	Black	60 - 110	3010158
CB 5065/1 - 5080/1	Pink	100 - 150	3090487
	Red	25 - 55	3010133
	Black	60 - 110	3010135
CB 50100/1	Pink	100 - 150	3090456
	Grey	140 - 200	3090992
	Red	25 - 55	3010134
CB 50125/1	Black	60 - 110	3010136
	Pink	100 - 150	3090489
	Grey	140 - 200	3092174
CB 50125/1	Red	25 - 55	3010315
	Yellow	30 - 70	3010316
	Black	60 - 110	3010317
	Pink	100 - 150	3010318

RS 310-410-510-610-810/E-/EV BLU SERIES

The RS 310-410-510-610-810/E-/EV Blu burners series covers a firing range from 1200 to 6250 kW, and it has been designed for use in low or medium temperature hot water boilers, hot air or steam boilers, diathermic oil boilers. It is based on the Digital Burner Management System, Riello REC27-37, which is able to manage the air-fuel ratio by independent servomotors in order to obtain a perfect output control and to assure a correct combustion and safe operation on all modulation range. Operation can be "two stage progressive" or, alternatively, "modulating" with the installation of a PID logic regulator and respective probes. RS/E-/EV BLU burners series guarantees high efficiency levels in all the various applications, thus reducing fuel consumption and running costs; specific versions are available to operate with Variable Speed Drive technology base on the control of a Frequency Inverter that modifies the air flow through the motor speed variation. The combustion head engineered with advanced simulation devices, guarantees reduced polluting emissions. The exclusive design ensures reduced dimensions, simple use and maintenance. A wide range of accessories guarantees elevated working flexibility.



RS 310/E-/EV BLU	400/1200 ÷ 3630 kW
RS 410/E-/EV BLU	500/1500 ÷ 4450 kW
RS 510/E-/EV BLU	680/1800 ÷ 5250 kW
RS 610/E-/EV BLU	1000/2200 ÷ 6250 kW
RS 810/E-/EV BLU	1200/3500 ÷ 8010 kW

FIRING RATES

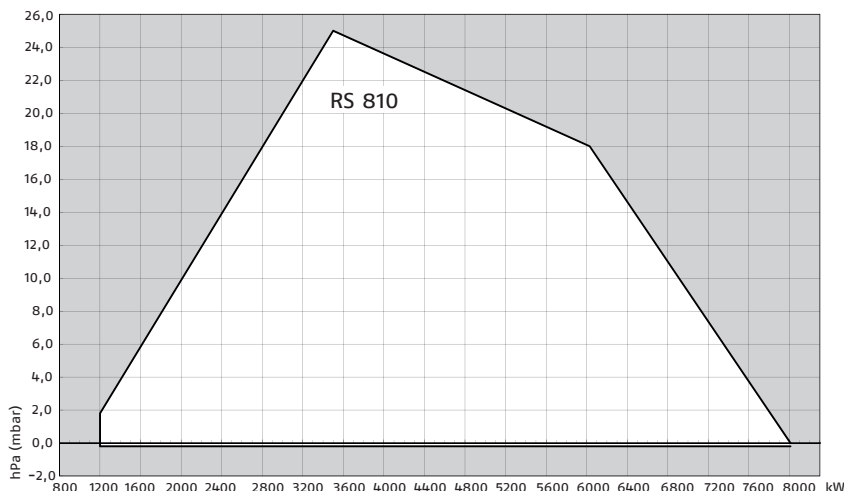
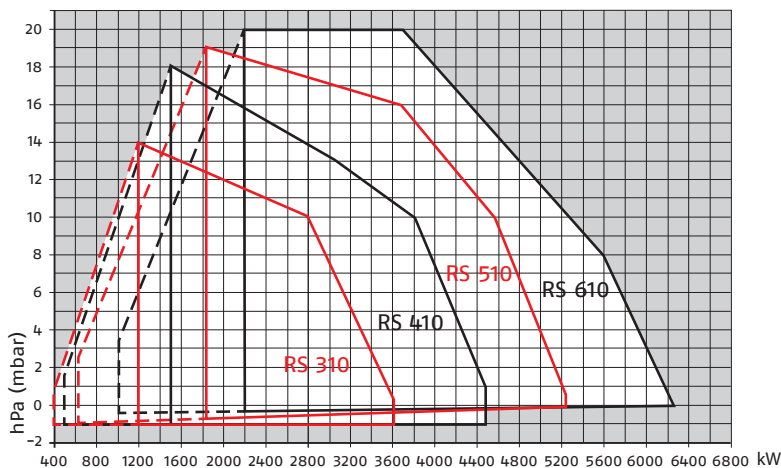

Useful working field for choosing the burner



Modulation range

Test conditions conforming to EN676
 Temperature: 20°C
 Pressure: 1013,5 mbar
 Altitude: 0 m a.s.l.

Low NOx Modulating Gas Burners

RS 310-410-510-610-810/E-/EV BLU SERIES

Overall dimensions (mm)

BURNER

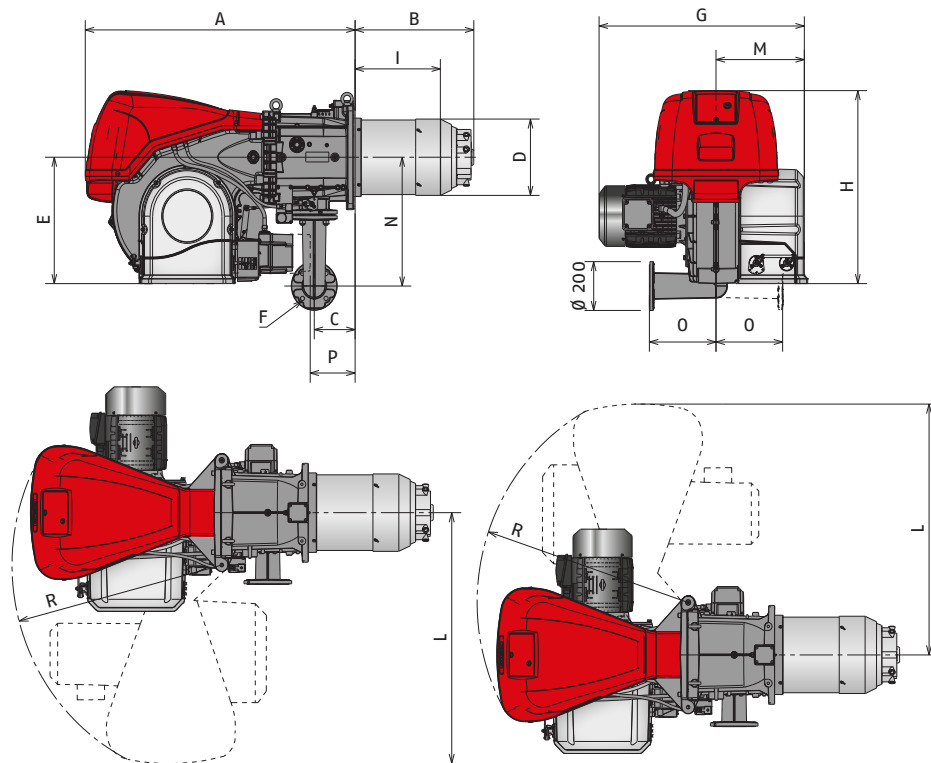

Model	A	B	C	D	E	F	G	H	I	L	M	N	O	P*	R
▶ RS 310/E-/EV BLU	1178	465	178	306	520	DN65	890	790	346	1015	400	528	290	177	890
▶ RS 410/E-/EV BLU	1178	517	178	313	520	DN65	908	790	365	930	400	528	290	177	890
▶ RS 510/E-/EV BLU	1178	517	178	313	520	DN65	908	790	365	930	400	528	290	177	890
▶ RS 610/E-/EV BLU	1178	517	178	336	520	DN65	980	790	360	1015	400	528	290	177	890
▶ RS 810/E-/EV BLU	1345	558	173	363	585	DN80	990	790	405	1197	413	528	290	177	1055

* Maximum position for the extraction of the servomotor cover in mechanical cam models.

BURNER - BOILER MOUNTING FLANGE

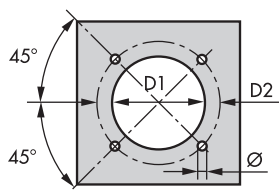

MODEL	D1	D2	Ø
▶ RS 310/E-/EV BLU	335	452	M18
▶ RS 410/E-/EV BLU	335	452	M18
▶ RS 510/E-/EV BLU	335	452	M18
▶ RS 610/E-/EV BLU	350	452	M18
▶ RS 810/E-/EV BLU	400	495	M18

PACKAGING

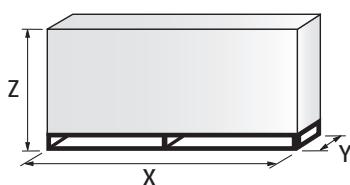

MODEL	X	Y	Z	kg
▶ RS 310/E-/EV BLU	2040	1180	1125	250
▶ RS 410/E-/EV BLU	2040	1180	1125	250
▶ RS 510/E-/EV BLU	2040	1180	1125	250
▶ RS 610/E-/EV BLU	2040	1180	1125	280
▶ RS 810/E-/EV BLU	2140	1200	1346	300

RS 310-410-510-610-810/E-/EV BLU SERIES

Specification

DESIGNATION OF SERIES

A specific index guides your choice of burner from the various models available in the RS/M BLU series. Below is a clear and detailed specification description of the product.

Series: R								
Fuel: S Natural Gas								
L Light oil								
LS Light oil/Natural Gas								
N Heavy oil								
Size:								
Setting: /1 Single stage								
/B Two stage								
/M Modulating-Mechanical cam								
/E Electronic cam								
/P Proportioning air/gas valve								
/EV Electronic cam predisposed for variable speed (with inverter)								
/EVi Electronic cam with integrated inverter								
Emission: ... or CO1	Class 1 EN676							
MZ	Class 2 EN676							
BLU	Class 3 EN676							
MX	Class 3 EN676							
Head length:	TC standard head							
	TL extended head							
Flame control system:	FS1 Standard/Intermittent (at least 1 stop every 24 h)							
	FS2 Continuous (1 stop every 72 h)							
Electrical supply to the system:								
1/230/50	1/230V/50Hz							
3/230/50	3/230V/50Hz							
3/400/50	3N/400V/50Hz							
3/230-400/50	3/230V/50Hz - 3N/400V/50Hz							
3/220/60	3/220V/60Hz							
3/380/60	3N/380V/60Hz							
3/220-380/60	3/220/60Hz - 3N/380V/60Hz							
Auxiliary voltage: 230/50-60	230V/50-60H							
	110/50-60 110V/50-60Hz							
R	S	510	/E	BLU	TC	FS1	3/230-400/50	230/50-60
BASIC DESIGNATION				EXTENDED DESIGNATION				

Low NOx Modulating Gas Burners

RS 310-410-510-610-810/E-/EV BLU SERIES

Specification

STATE OF SUPPLY

Monoblock forced draught Low NOx gas burners with two stage progressive or modulating operation, with a specific kit, fully automatic, made up of:

- Microprocessor-based Digital Burner Management System (RS/E BLU models)
- Microprocessor-based Digital Burner Management System with Variable Speed Drive technology for the control of a Frequency Inverter (RS/EV BLU models)
- Display Interface operating unit to adjust the system
- Air suction circuit lined with sound-proofing material
- High performance fan with low sound emissions, forward curve blades
- Air damper for air flow setting and butterfly valve for regulating fuel output controlled by independent stepper motor actuators
- Air pressure switch
- Fan starting motor at 2900 rpm, three-phase 230/400 - 400/690 V with neutral, 50 Hz
- Combustion head, that can be set on the basis of required output, fitted with:
 - stainless steel end cone, resistant to corrosion and high temperatures
 - ignition electrodes; ionisation sensor for flame detection (or UV sensor on demand)
 - flame stability disk
- Maximum gas pressure switch, with pressure test point, for halting the burner in the case of over pressure on the fuel supply line
- Star/delta starter for the fan motor (Direct starter fan motor for RS 310-410 models)
- Main electrical supply terminal board
- Burner on/off switch
- Manual or automatic output increase/decrease switch
- Contacts motor and thermal relay with release button
- Burner failure led signal and lighted release button
- Burner opening hinge
- Lifting rings
- IP 54 electric protection level

Standard equipment:

Gasket for gas train adaptor

Adaptor for gas train

Screws for fixing the gas train adaptor: M 16 x 70

Thermal insulation screen

M 18 x 60 screws to secure the burner flange to the boiler

Cable grommets kit for optional electrical wiring input

M16 x 6 studs for fixing the gas elbow to the pipe coupling

M16 nuts to fix the gas elbow to the pipe coupling

Instruction handbook for installation, use and maintenance

Spare parts catalogue

Gas train

Fuel supply line, in the MULTIBLOC configuration (for a diameter of 1-1/2" and 2") or COMPOSED configuration (from a diameter of DN 65 until a diameter of DN 125), fitted with:

- Filter
- Stabiliser
- Minimum gas pressure switch
- Safety valve
- One stage working valve with ignition gas output regulator.

RS 310-410-510-610-810/E-/EV BLU SERIES

Specification

Conforming to:

- 2014/30/EU directive (electromagnetic compatibility)
- 2014/35/EU directive (low voltage)
- 2016/426/EU gas regulation (GAR)
- 2006/42 EC directive (machine)
- 2014/68/EU Pressure Equipment Directive
- EN 676 (gas burners).

Available accessories to be ordered separately:

- Power controller
- Probe
- Continuous ventilation kit
- UV cell kit
- Variable speed drive (VSD) kit (for RS/EV series only)
- PC interface kit
- OCI412 Interface kit
- Sound proofing box
- Spacer kit
- Adapters
- PVP (Pressure Proving System)
- Stabiliser spring.

Low NOx Modulating Gas Burners

RS 310-410-510-610-810/E-/EV BLU SERIES

Available models

Burners

CODE	MODEL				HEAT OUTPUT		TOTAL ELECTRICAL POWER (kW)	CERTIFICATION	NOTE
					NATURAL GAS				
					(kW)	(Nm ³ /h)			
20065783	RS 310/E BLU	TC	FS1	3/400/50	400/1200-3630	40/120-363	8,8	CE-0085CP0166	(1)
20068261	RS 310/E BLU	TC	FS1	3/400/50	400/1200-3630	40/120-363	9,1	CE-0085CP0166	
20074257	RS 310/E BLU	TC	FS2	3/400/50	400/1200-3630	40/120-363	8,8	CE-0085CP0166	(1)
20074254	RS 310/E BLU	TC	FS2	3/400/50	400/1200-3630	40/120-363	9,1	CE-0085CP0166	
20056927	RS 410/E BLU	TC	FS1	3/400/50	500/1500-4450	50/150-445	10,6	CE-0085CP0166	(1)
20068294	RS 410/E BLU	TC	FS1	3/400/50	500/1500-4450	50/150-445	10,6	CE-0085CP0166	
20074258	RS 410/E BLU	TC	FS2	3/400/50	500/1500-4450	50/150-445	10,6	CE-0085CP0166	(1)
20074256	RS 410/E BLU	TC	FS2	3/400/50	500/1500-4450	50/150-445	10,6	CE-0085CP0166	
20056930	RS 510/E BLU	TC	FS1	3/400/50	680/1800-5250	68/180-525	13,9	CE-0085CP0166	(1)
20074259	RS 510/E BLU	TC	FS2	3/400/50	680/1800-5250	68/180-525	13,9	CE-0085CP0166	(1)
20056932	RS 610/E BLU	TC	FS1	3/400/50	1000/2200-6250	100/220-625	16,9	CE-0085CP0166	(1)
20074252	RS 610/E BLU	TC	FS2	3/400/50	1000/2200-6250	100/220-625	16,9	CE-0085CP0166	(1)
20160126	RS 810/E BLU	TC	FS1/FS2	3/400/50	1200/3500-8010	120/350-801	24,5	CE-0123CU1067	(1)
20074269	RS 310/EV BLU	TC	FS1/FS2	3/400/50	400/1200-3630	40/120-363	9,1	CE-0085CP0166	
20074271	RS 410/EV BLU	TC	FS1/FS2	3/400/50	500/1500-4450	50/150-445	10,8	CE-0085CP0166	
20074272	RS 510/EV BLU	TC	FS1/FS2	3/400/50	680/1800-5250	68/180-525	14	CE-0085CP0166	
20074273	RS 610/EV BLU	TC	FS1/FS2	3/400/50	1000/2200-6250	100/220-625	17	CE-0085CP0166	
20160292	RS 810/EV BLU	TC	FS1/FS2	3/400/50	1200/3500-8010	120/350-801	24,5	CE-0123CU1067	

Natural gas, net calorific value: 10 kWh/Nm³ - Density: 0,71 kg/Nm³

The burners of RS/E-/EV BLU series are in according to 2016/426/EU - 2014/30/EU - 2014/35/EU - 2014/68/UE - 2006/42 EC Directive.

(1) Star delta starter

RS 310-410-510-610-810/E-/EV BLU SERIES

Available models

Gas Trains

CODE	GAS TRAIN		ADAPTER CODE				
	MODEL	∅	RS 310	RS 410	RS 510	RS 610	RS 810
3970250*	MB 415/1 - RT 52	Rp 1" 1/2	3000826 + 20064220	●	●	●	●
3970257*	MB 420/1 - RT 52	Rp 2"	3000826 + 20042324	●	●	●	●
3970221*	MBC 1200/1 - RSM 60	Rp 2"	3000826 + 20042324				(20042324+20064169)/(20068062) (1)
3970222*	MBC 1900/1 - FSM 40	DN 65	3010221				20059330/ (20065924 + 20059330) (1)
3970223*	MBC 3100/1 - FSM 40	DN 80	3010222				20059331/ (20065937 + 20059331) (1)
3970224*	MBC 5000/1 - FSM 80	DN 100	3010222 - 3010370				20059332 / (20065960 + 20059332) (1)
3970145*	CB 512/1 - RSM 30	Rp 1" 1/2	3000826 + 20064220	●	●	●	●
3970146*	CB 520/1 - RSM 30	Rp 2"	3000826 + 20042324		●	●	●
20044659*	CB 525/1 - RSM 30	Rp 2"	3000826 + 20042324				●
3970147*	CB 5065/1 - FSM 30	DN 65	3010221				20059330/ (20065924 + 20059330) (1)
3970148*	CB 5080/1 - FSM 30	DN 80	3010222				20059331/ (20065937 + 20059331) (1)
3970149*	CB 50100/1 - FSM 30	DN 100	3010223 - 3010370				20059332/ (20065960 + 20059332) (1)
20015871*	CB 50125/1 - FSM 30	DN 125	3010224				20059333/ (20065968 + 20059333) (1)

Please see designation of Gas Train Series in the page before the Catalogue index.

* 230V/50Hz ~220V/60Hz electrical supply.

** 230V/50Hz electrical supply.

The valves seal control device is compulsory (conforming to EN 676) on gas trains to burners with a maximum output over 1200 kW.

The seal control function is managed by REC control box, by installation on gas train of a pressure switch (please see Gas train accessories paragraph).

To select the gas train please refer to the technical data leaflet and/or instruction manual.

● Not available.

□ Additional adapter not necessary, the gas train may be connected directly to the burner.

1) To be used with gas train and burner opening on the left (fan motor side).

Low NOx Modulating Gas Burners

RS 310-410-510-610-810/E-/EV BLU SERIES

Burner accessories

Accessories for modulating operation

POWER CONTROLLER



To obtain modulating operation, the RS/E-/EV BLU series of burners requires a regulator with three point outlet controls.

The following table lists the accessories for modulating operation with their application range.

For remote setpoint use RWF 55.

BURNER	TYPE	KIT CODE
► All models	RWF 50.2 - Basic version with 3 position output	20085417
	RWF 55.5 - Complete with RS-485 interface	20074441
	RWF 55.6 - Complete with RS-485/ PROFIBUS interface	20074442

PROBE



The relative temperature or pressure probes fitted to the power controller must be chosen on the basis of the application.

BURNER	TYPE	RANGE (°C) (BAR)	KIT CODE
► All models	Temperature PT 100	-100 ÷ 500°C	3010110
	Pressure 4 ÷ 20 mA	0 ÷ 2,5 bar	3010213
	Pressure 4 ÷ 20 mA	0 ÷ 16 bar	3010214
	Pressure 4 ÷ 20 mA	0 ÷ 25 bar	3090873

Continuous ventilation kit



If the burner requires continuous ventilation in the stages without flame, a special kit is available as given in the following table:

BURNER	KIT CODE
► RS 310-410-510-610/E	20074542
► RS 810/E-/EV	20074542

Uv cell kit



A UV cell is available for the supervision of the flame alternatively to ionisation probe for special applications.

BURNER	KIT CODE
► RS 310-410-510-610-810/E-/EV	20077814

Pc interface kit



To connect the control panel to a personal computer for the transmission of operation, fault signals and detailed service information, an interface adapter with PC software are available.

BURNER	KIT CODE
► RS 310-410-510-610-810/E-/EV (ACS410 + OCI410.30) - Service level	3010436

RS 310-410-510-610-810/E-/EV BLU SERIES

Burner accessories

Variable Speed Drive (VSD) for RS/EV series only



The motor speed variation for the RS/EV BLU burners series is obtained thanks to a frequency converter: variable speed drive (VSD), provided with a programming panel with start-up assistant. It always must be ordered with RS/EV series.

BURNER	ELECTRICAL SUPPLY	MOTOR POWER (kW)	INVERTER POWER (kW)	KIT CODE
▶ RS 310/EV	230	7,5	7,5	On demand
▶ RS 310/EV	400	7,5	7,5	20163074
▶ RS 410/EV	230	9,2	11	On demand
▶ RS 410/EV	400	9,2	11	20163093
▶ RS 510/EV	400	12	15	20163096
▶ RS 610/EV	400	15	15	20163096
▶ RS 810/EV	400	22	22	20163099

The use of inverters other than those indicated by the manufacturer may lead to burner failure and, in extreme cases, a potential risk of harm to people and damage to property. The manufacturing company shall not be liable for any such damage arising from non-observance of the requirements contained in the burner manual.

OCI412 interface kit



Interface kit between the REC 27.1 and a Modbus system, such as a building automation and control system (BACS). The Modbus interface is based on the RS-485 standard.

BURNER	KIT CODE
▶ RS 310-410-510-610-810/E-/EV	3010437

Sound proofing box

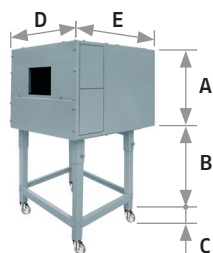

If noise emission needs reducing even further, sound-proofing boxes are available.

When a lower "B" dimension is required, it is available the Box Support Kit code 20065135 which allows to reduce it at the fixed dimension of 55 mm. The sound-proofing boxes are not suitable for outdoor use.

BURNER	BOX TYPE	A (mm)	B (mm) min. - max	C (mm)	D (mm)	E (mm)	[dB(A)] (*)	KIT CODE
▶ RS 310-410-810/E-/EV	C7	1255	160 - 980	110	1140	1345	10	3010376
▶ RS 610/E-/EV	C7 PLUS	1255	270 - 1090	110	1240	1345	10	20085111
▶ RS 310-410/E-/EV ▶ RS510/E-/EV	C7	1255	165	110	1140	1345	10	20027778

(*) Average noise reduction according to EN 15036-1 standard

Spacer kit

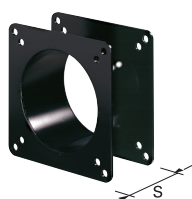

If burner head penetration into the combustion chamber needs reducing, varying thickness spacers are available, as given in the following table:

BURNER	Spacer thickness S (mm)	KIT CODE
▶ All models	180	20008903









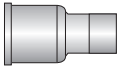
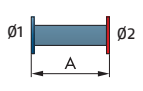
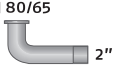

Low NOx Modulating Gas Burners

RS 310-410-510-610-810/E-/EV BLU SERIES

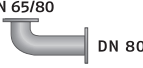
Gas train accessories

Adapters

In certain cases, an adapter must be fitted between the gas train and the burner, when the diameter of the gas train is different from the set diameter of the burner. Below are given the available adapters; please see on the Gas Train list the correct adapter codes to select.

ADAPTER	DIMENSIONS		ADAPTER CODE		
	Ø1 DN	Ø2 DN		A mm	B mm
1" 1/2  2"	-	-	65	-	20064220
2"  2"	-	-	65	-	20042324
DN 80  2" 1/2  2"	-	-	300	-	3000826
	65	80	400	-	3010221
	80	80	400	-	3010222
	100	80	400	-	3010223
	125	80	320	-	3010224
DN 80/65  2"			230	-	20064169
DN 80/65  2"			780	-	20068062
DN 65/80  DN 65			230	-	20059330
DN 65/80  DN 80			230	-	20059331
DN 65/80  DN 100			230	-	20059332
DN 65/80  DN 125			245	-	20059333
DN 65  DN 65			800	-	20065924
DN 80  DN 80			800	-	20065937
DN 100  DN 100			800	-	20065960
DN 125  DN 125			800	-	20065968

PVP (pressure valve proving kit)

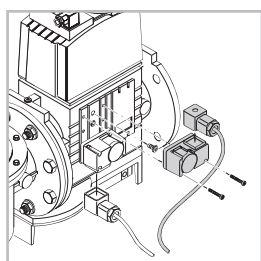

The seal control function is included on Burner Digital Management System, it is only necessary to add the PVP kit on the gas train.

GAS TRAIN	CODE
▶ MB - CB - MBC type	3010344

RS 310-410-510-610-810/E-/EV BLU SERIES

Stabiliser spring



To vary the pressure range of the gas train stabilisers, accessory springs are available. The following table shows these accessories with their application range. Please refer to the technical manual for the correct choice of spring.

GAS TRAIN	SPRING COLOUR	SPRING Pressure range mbar	SPRING CODE
MBC 1900/1 - 3100/1 MBC 5000/1	White	4 - 20	3010381
	Red	20 - 40	3010382
	Black	40 - 80	3010383
CB 512/1	Green	80 - 150	3010384
	Red	25 - 55	3010131
	Black	60 - 110	3010157
CB 520/1 - 525/1	Pink	90 - 150	3090486
	Red	25 - 55	3010132
	Black	60 - 110	3010158
CB 5065/1 - 5080/1	Pink	100 - 150	3090487
	Red	25 - 55	3010133
	Black	60 - 110	3010135
CB 50100/1	Pink	100 - 150	3090456
	Grey	140 - 200	3090992
	Red	25 - 55	3010134
CB 50125/1	Black	60 - 110	3010136
	Pink	100 - 150	3090489
	Grey	140 - 200	3092174
	Red	25 - 55	3010315
	Yellow	30 - 70	3010316
	Black	60 - 110	3010317
	Pink	100 - 150	3010318

RS 1000÷1200/M BLU SERIES

The RS 1000–1200/M BLU burners are characterised by a monoblock structure which means that all necessary components are combined in a single unit, making installation easier and faster.

The burners cover a firing range from 4000 to 11100 kW, and they have been designed for use in hot water boilers or industrial steam generators.

Operation can be “two stage progressive” or alternatively “modulating” with the installation of a PID logic regulator or by external 4–20 mA/0–10 V signal.

The mechanical cam device of regulation allows to catch up a high modulation ratio on all firing rates range. The burners can, therefore, supply with precision the demanded power, guaranteeing a high efficiency system level and the stability setting, obtaining fuel consumption and operating costs reduction.

The combustion head, engineered with advanced simulation devices, guarantees reduced polluting emissions ($\text{NO}_x < 80 \text{ mg/kWh}$).

FS1 and FS2 versions are available for intermittent and continuous operation applications.

An exclusive design, guarantees low sound emissions, low electrical consumption, easy use and maintenance.



RS 1000/M BLU	1100/4000 ÷ 10100 kW
RS 1200/M BLU	1500/5500 ÷ 11100 kW

FIRING RATES

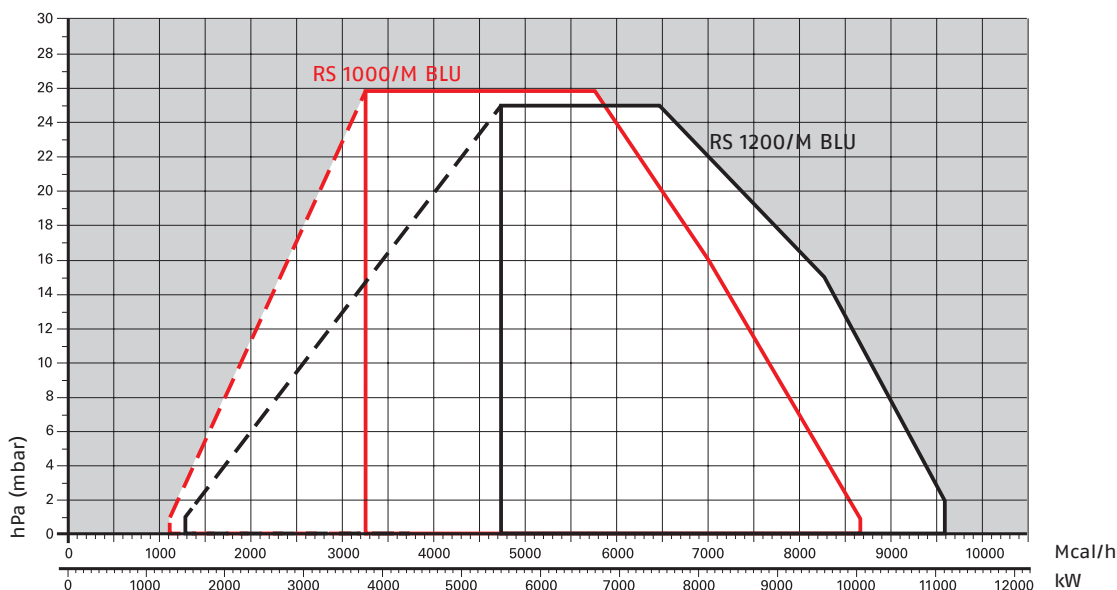

Useful working field for choosing the burner



Modulation range

Test conditions conforming to EN676
 Temperature: 20°C
 Pressure: 1013,5 mbar
 Altitude: 0 m a.s.l.

Low NOx Modulating Gas Burners

RS 1000÷1200/M BLU SERIES

Overall dimensions (mm)

BURNER

RS 1000-1200/M BLU

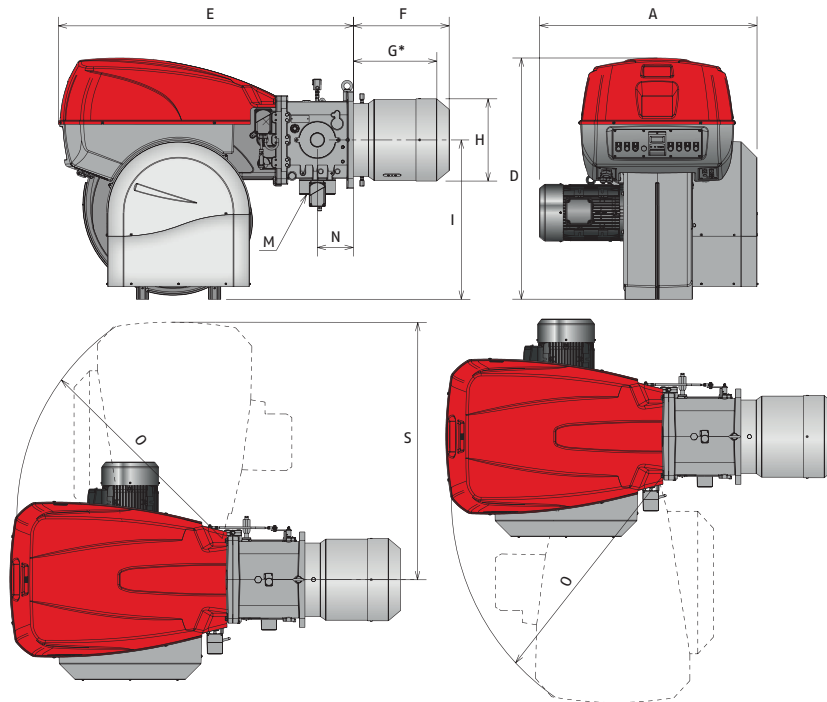

MODEL	A	D	E	F	G*	H	I	M	N	O	S
▶ RS 1000/M BLU	1206	1338	1637	669	485	413	885	DN80	200	1350	1493
▶ RS 1200/M BLU	1250	1338	1637	670	454	456	885	DN80	200	1350	1493

* Maximum depth of the boiler door including the depth of the burner flange insulating gasket.

BURNER - BOILER MOUNTING FLANGE

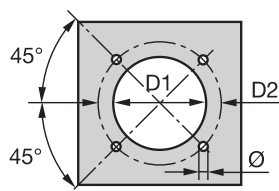

MODEL	D1	D2	Ø
▶ RS 1000/M BLU	460	608	M20
▶ RS 1200/M BLU	500	608	M20

PACKAGING

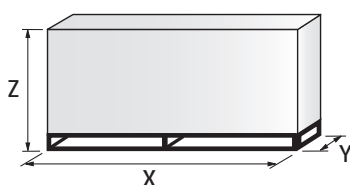

MODEL	X	Y	Z	kg
▶ RS 1000/M BLU	2400	1400	1595	500
▶ RS 1200/M BLU	2400	1400	1595	550

RS 1000÷1200/M BLU SERIES

Specification

DESIGNATION OF SERIES

Series: R

Fuel: S Natural Gas
 L Light oil
 LS Light oil/Natural Gas
 N Heavy oil

Size:

Setting: /1 Single stage
 /B Two stage
 /M Modulating-Mechanical cam
 /E Electronic cam
 /P Proportioning air/gas valve
 /EV Electronic cam predisposed for variable speed (with inverter)
 /EVi Electronic cam with integrated inverter

Emission: ... or C01 Class 1 EN676
 MZ Class 2 EN676
 BLU Class 3 EN676
 MX Class 3 EN676

Head length: TC standard head
 TL extended head

Flame control system: FS1 Standard/Intermittent (at least 1 stop every 24 h)
 FS2 Continuous (1 stop every 72 h)

Electrical supply to the system:

1/230/50	1/230V/50Hz
3/230/50	3/230V/50Hz
3/400/50	3N/400V/50Hz
3/230-400/50	3/230V/50Hz - 3N/400V/50Hz
3/220/60	3/220V/60Hz
3/380/60	3N/380V/60Hz
3/220-380/60	3/220/60Hz - 3N/380V/60Hz

Auxiliary voltage: 230/50-60 230V/50-60H
 110/50-60 110V/50-60Hz

R S 1000 /M BLU TC FS2 3/230-400/50 230/50-60

BASIC DESIGNATION

EXTENDED DESIGNATION

Specification

STATE OF SUPPLY

Monoblock forced draught gas burner with modulating operation, fully automatic, made up of:

- High performance fan with low sound emissions, reverse curve blades for RS 1000-1200/M BLU
- Air suction circuit lined with sound-proofing material
- Air damper for air setting controlled by a high precision servomotor
- Air pressure switch
- Fan starting motor at 2900 rpm, three-phase 230/400 - 400/690 V with neutral, 50 Hz
- Low emission combustion head, that can be set on the basis of required output, fitted with:
 - stainless steel end cone, resistant to corrosion and high temperatures
 - ignition electrodes; or UV sensor (RS 1000-1200) for flame detection
 - flame stability disk
- Maximum gas pressure switch, with pressure test point, for halting the burner in the case of over pressure on the fuel supply line
- Burner safety control box for controlling the system safety (RMG/M for FS1 intermittent operation - RFG0 for FS1 intermittent operation for RS 1000-1200 model - LGK16 for FS2 continuous operation)
- UV photocell or ionisation probe for flame detection
- Star/delta starter for the fan motor
- Main electrical supply terminal board
- Burner on/off switch
- Auxiliary voltage led signal
- Manual or automatic output increase/decrease switch
- Burner working led signal
- Contacts motor and thermal relay with release button
- Motor internal thermal protection
- Motor failure led signal
- Burner failure led signal and lighted release button
- Led signal for correct rotation direction of fan motor
- Emergency button
- Coded connection plugs-sockets
- Burner opening hinge
- Lifting rings
- IP 54 electric protection level

Standard equipment:

- 1 flange gasket
- 8 screws for fixing the flange
- 1 thermal screen
- 4 screws for fixing the burner flange to the boiler
- Instruction handbook for installation, use and maintenance
- Spare parts catalogue.

RS 1000÷1200/M BLU SERIES

Available models

Burners

CODE	MODEL	HEAT OUTPUT NATURAL GAS		TOTAL ELECTRICAL POWER (kW)	CERTIFICATION	NOTE
		(kW)	(Nm ³ /h)			
20145840	RS 1000/M BLU TC FS1/FS2 3/400/50 230/50-60	1100/4000-10100	130/380-940	24	CE-0085CN0119	(1) (2) (4) (6)
20145959	RS 1000/M BLU TC FS1/FS2 3/400/50 230/50-60	1100/4000-10100	130/380-940	24	CE-0085CN0119	(1) (3) (4) (6)
20145867	RS 1200/M BLU TC FS1/FS2 3/400/50 230/50-60	1500/5500-11100	150/550-1150	27,2	CE-0085CN0120	(1) (2) (4) (6)
20145958	RS 1200/M BLU TC FS1/FS2 3/400/50 230/50-60	1500/5500-11100	150/550-1150	27,2	CE-0085CN0120	(1) (3) (4) (6)

Natural gas, net calorific value: 10 kWh/Nm³ - Density: 0,71 kg/Nm³

(1) according to 2016/426/EU - 2014/30/EU - 2014/35/EU - 2006/42 EC Directives and 2014/68/EU Pressure Equipment Directive (only FS2 version)

(2) UV photocell

(3) ionization probe

(4) FS2 operation is allowed with ionization probe only, no other flame sensors can be used.

(5) with RMG/M control box

(6) with RFG0 control box

(7) with LFL control box

Due to the improvement applied on the technical specification of some products, some burner codes will change during year 2019. The table below summarizes the correspondence between the previous and the new code.

MODEL				NEW CODE		OLD CODE	
RS 1000/M BLU	TC	FS1/FS2	3/400/50	20145840	(6)	20051940	(7)
RS 1000/M BLU	TC	FS1/FS2	3/400/50	20145959	(6)	20051941	(7)
RS 1200/M BLU	TC	FS1/FS2	3/400/50	20145867	(6)	20072965	(7)
RS 1200/M BLU	TC	FS1/FS2	3/400/50	20145958	(6)	20072966	(7)

Low NOx Modulating Gas Burners

RS 1000÷1200/M BLU SERIES

Available models

Gas Trains

Code	Gas train			VPS Code	Adapter Code	
	Model	Ø	C.T.		RS 1000	RS 1200
3970221*	MBC 1200/1 - RSM 60	Rp 2"	-	3010123	20066263 / (20065924 + 20066263) ¹	
3970225**	MBC 1200/1 CT RSM 60	Rp 2"	◆	-		
3970222*	MBC 1900/1 - FSM 40	DN 65	-	3010123	20066263 / (20065924 + 20066263) ¹	
3970226**	MBC 1900/1 CT FSM 40	DN 65	◆	-		
3970223*	MBC 3100/1 - FSM 40	DN 80	-	3010123	20066268 / (20065937 + 20066268) ¹	
3970227**	MBC 3100/1 CT FSM 40	DN 80	◆	-		
3970224*	MBC 5000/1 - FSM 80	DN 100	-	3010123	20066278 / (20065960 + 20066278) ¹	
3970228**	MBC 5000/1 CT FSM 80	DN 100	◆	-		
3970147*	CB 5065/1 - FSM 30	DN 65	-	3010123	20066263 / (20065924 + 20066263) ¹	
3970161**	CB 5065/1 CT FSM 30	DN 65	◆	-		
3970148*	CB 5080/1 - FSM 30	DN 80	-	3010123	20066268 / (20065937 + 20066268) ¹	
3970162**	CB 5080/1 CT FSM 30	DN 80	◆	-		
3970149*	CB 50100/1 - FSM 30	DN 100	-	3010123	20066278 / (20065960 + 20066278) ¹	
3970163**	CB 50100/1 CT FSM 30	DN 100	◆	-		
20015871*	CB 50125/1 - FSM 30	DN 125	-	3010123	20066284 / (20065968 + 20066284) ¹	
3970196**	CB 50125/1 CT FSM 30	DN 125	◆	-		

Please see designation of Gas Train Series in the page before the Catalogue index.

* 230V/50Hz -220V/60Hz electrical supply.

** 230V/50Hz electrical supply.

The valve seal control device is compulsory (conforming to EN 676) on gas trains to burners with a maximum output over 1200 kW.

To select the gas train please refer to the technical data leaflet and/or instruction manual.

C.T. Gas valve leak detection control device:

- gas train not equipped with leak detection control device; this device can be ordered separately - see VPS column - and installed later.
- ◆ gas train equipped with leak detection control device.

VPS Valve leak detection control device. Supplied separately from the gas train (please see Gas train accessories paragraph for both 50 Hz and 60 Hz codes).

● Not available.

□ Additional adapter not necessary, the gas train may be connected directly to the burner.

1) To be used with gas train and burner opening on the left (fan motor side).

2) To be used with /M (mechanical cam) burners, gas train on the left (fan motor side) and burner opening on the right.

Burner accessories

Accessories for modulating operation

POWER CONTROLLER



To obtain modulating operation, the RS/M BLU series of burners requires a regulator with three point outlet controls. The following table lists the accessories for modulating operation with their application range. For remote setpoint use RWF 55.

BURNER	TYPE	CODE
► All models	RWF 50.2	20101190
	RWF 55.5	20101191

PROBE



The relative temperature or pressure probes fitted to the power controller must be chosen on the basis of the application.

BURNER	TYPE	RANGE (°C) (bar)	CODE
► All models	Temperature PT 100	-100 ÷ 500°C	3010110
	Pressure 4 ÷ 20 mA	0 ÷ 2,5 bar	3010213
	Pressure 4 ÷ 20 mA	0 ÷ 16 bar	3010214
	Pressure 4 ÷ 20 mA	0 ÷ 25 bar	3090873

ANALOG CONTROL SIGNAL CONVERTER



BURNER	TYPE (INPUT SIGNAL)	CODE
► All models	0/2 - 10 V (impedance 200 KΩ) 0/4 - 20 mA (impedance 250 Ω)	3010390

POTENTIOMETER



BURNER	KIT CODE
► RS 1000-1200/M BLU	-

Low NOx Modulating Gas Burners

RS 1000÷1200/M BLU SERIES

Burner accessories

Continuous ventilation kit



If the burner requires continuous ventilation in the stages without flame, a special kit is available as given in the following table:

BURNER	KIT CODE
► RS 1000–1200/M BLU	20086519

Sound proofing box

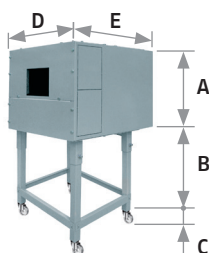

If noise emission needs reducing even further, sound-proofing boxes are available. When a lower “B” dimension is required, it is available the Box Support Kit code 20065135 which allows to reduce it at the fixed dimension of 55 mm. The sound-proofing boxes are not suitable for outdoor use.

BURNER	BOX TYPE	A (mm)	B (mm) min-max	C (mm)	D (mm)	E (mm)	[dB(A)] (*)	BOX CODE
► RS 1000–1200/M BLU	C8	1425	285 - 1000	110	1500	1800	10	3010401





(*) Average noise reduction according to EN 15036-1 standard

RS 1000÷1200/M BLU SERIES

Gas train accessories

Adapters

In certain cases, an adapter must be fitted between the gas train and the burner, when the diameter of the gas train is different from the set diameter of the burner. Below are given the available adapters; please see on the Gas Train list the correct adapter codes to select.

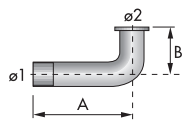
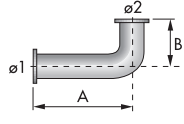
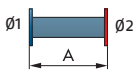
ADAPTER	DIMENSIONS				ADAPTER CODE
	Ø1 DN	Ø2 DN	A mm	B mm	
1" 1/2  2"	-	-	65	-	20064220
2"  2"	-	-	65	-	20042324
DN 80  2" 1/2  2"	-	-	300	-	3000826
	2"	65 / 80	230	230	20064169
	2"	65 / 80	780	230	20068062
	2"	65 / 80	780	230	20068058
	65	65 / 80	230	230	20059330
	80	65 / 80	230	230	20059331
	100	65 / 80	230	230	20059332
	125	65 / 80	245	230	20059333
	2"	65 / 80	230	375	20066253
	65	65 / 80	230	375	20066263
	80	65 / 80	230	375	20066268
	100	65 / 80	230	375	20066278
	125	65 / 80	245	375	20066284
	65	80	400	-	3010221
	80	80	400	-	3010222
	100	80	400	-	3010223
	125	80	320	-	3010224
	65	65	800	-	20065924
	80	80	800	-	20065937
	100	100	800	-	20065960
	125	125	800	-	20065968
					

Low NOx Modulating Gas Burners

RS 1000÷1200/M BLU SERIES

Gas train accessories

Stabiliser spring



To vary the pressure range of the gas train stabilisers, accessory springs are available. The following table shows these accessories with their application range. Please refer to the technical manual for the correct choice of spring.

GAS TRAIN	SPRING COLOUR	SPRING PRESSURE RANGE mbar	SPRING CODE
▶ MBC 1900/1 - 3100/1 MBC 5000/1	White	4 - 20	3010381
	Red	20 - 40	3010382
	Black	40 - 80	3010383
▶ CB 512/1	Green	80 - 150	3010384
	Red	25 - 55	3010131
	Black	60 - 110	3010157
▶ CB 520/1 - 525/1	Pink	90 - 150	3090486
	Red	25 - 55	3010132
	Black	60 - 110	3010158
▶ CB 5065/1 - 5080/1	Pink	100 - 150	3090487
	Red	25 - 55	3010133
	Black	60 - 110	3010135
▶ CB 50100/1	Pink	100 - 150	3090456
	Grey	140 - 200	3090992
	Red	25 - 55	3010134
▶ CB 50125/1	Black	60 - 110	3010136
	Pink	100 - 150	3090489
	Grey	140 - 200	3092174
▶ CB 50125/1	Red	25 - 55	3010315
	Yellow	30 - 70	3010316
	Black	60 - 110	3010317
	Pink	100 - 150	3010318

Seal control kit



To test the valve seals on the gas train, a special "seal control kit" is available. The valve seal control device is compulsory (EN 676) on gas trains to burners with a maximum output over 1200 kW. The seal control is type VPS 504.

GAS TRAIN	KIT CODE for 50 Hz operation	KIT CODE for 60 Hz operation
▶ MB/1 type	3010123	20168805
▶ MCB/1 type	3010123	20168805

RS 300÷2000/E-/EV BLU SERIES

The RS/E and RS/EV series burners are characterised by a modular monoblock structure that means all necessary components can be combined in a single unit thus making installation easier, faster and, above all, more flexible. The burners cover a firing range from 1350 to 19500 kW, and they have been designed for use in hot water boilers or industrial steam generators.

Operation can be modulating on the RS/E series and modulating with variable speed drive operation on RS/EV series.

The mechanisms of regulation allow to catch up a high modulation ratio on all firing rates range.

The burner can, therefore, supply with precision the demanded power, guaranteeing an high efficiency system level and the stability setting, obtaining fuel consumption and operating costs reduction.

The burner operation can be intermittent or continuous by menu setting.

The innovative combustion head, adjustment system ensures perfect movement during modulation as well as reducing noise and pollutants.

RS 300/EV BLU	500/1350 ÷ 3800 kW
RS 400/EV BLU	800/1840 ÷ 4550 kW
RS 500/EV BLU	1000/2500 ÷ 5170 kW
RS 650/EV BLU	1410/3000 ÷ 6500 kW
RS 800/EV BLU	1200/3500 ÷ 8100 kW
RS 1000/E-/EV BLU	1100/4000 ÷ 10100 kW
RS 1200/E-/EV BLU	1500/5500 ÷ 11100 kW
RS 1300/E-/EV BLU	2500/7500 ÷ 13000 kW
RS 1600/E-/EV BLU	3065/9503 ÷ 15560 kW
RS 2000/E-/EV BLU	4000/12000 ÷ 19500 kW

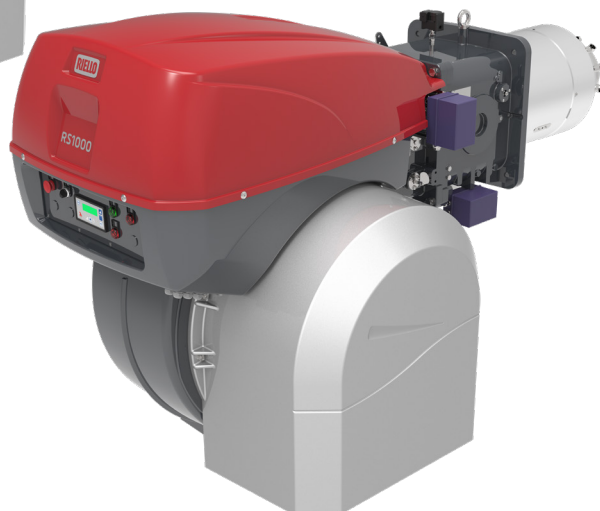
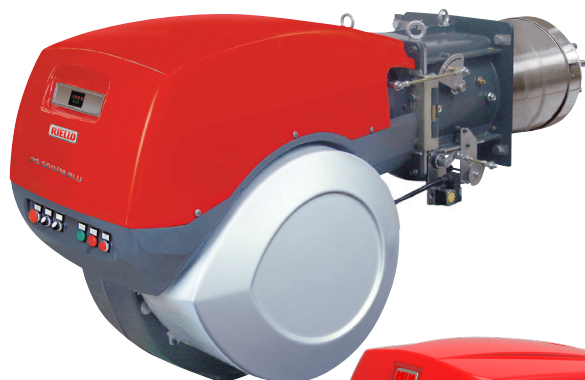

Low NOx Modulating Gas Burners

RS 300÷2000/E-/EV BLU SERIES

FIRING RATES

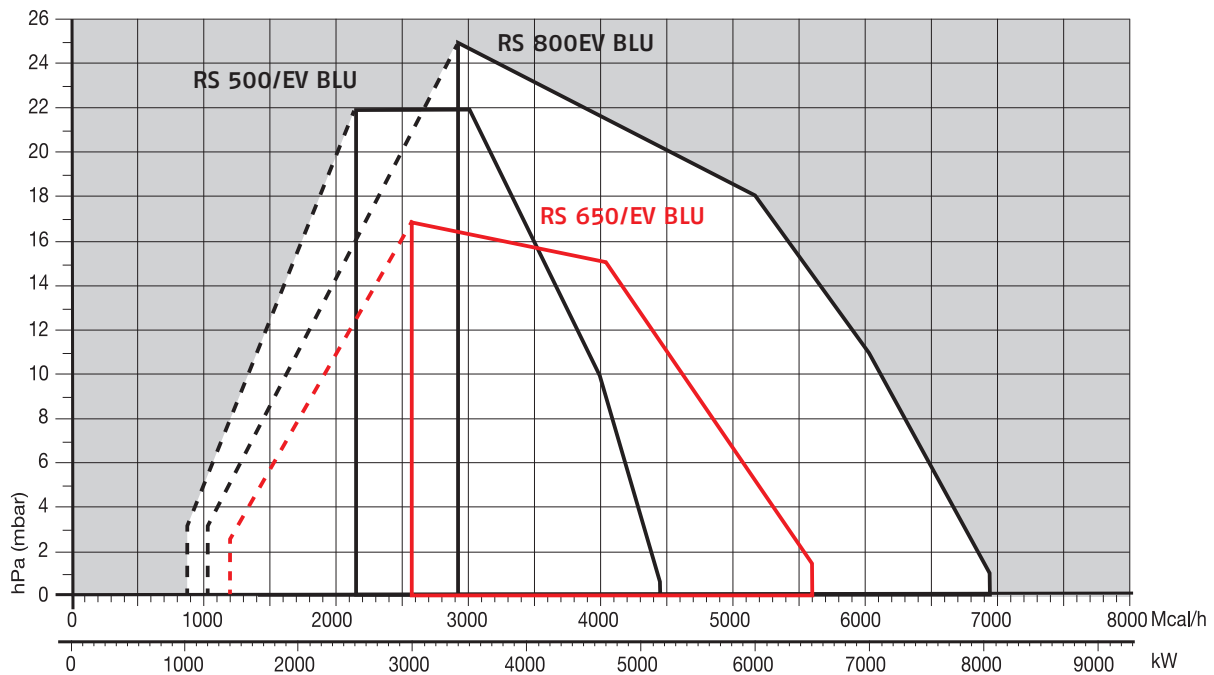
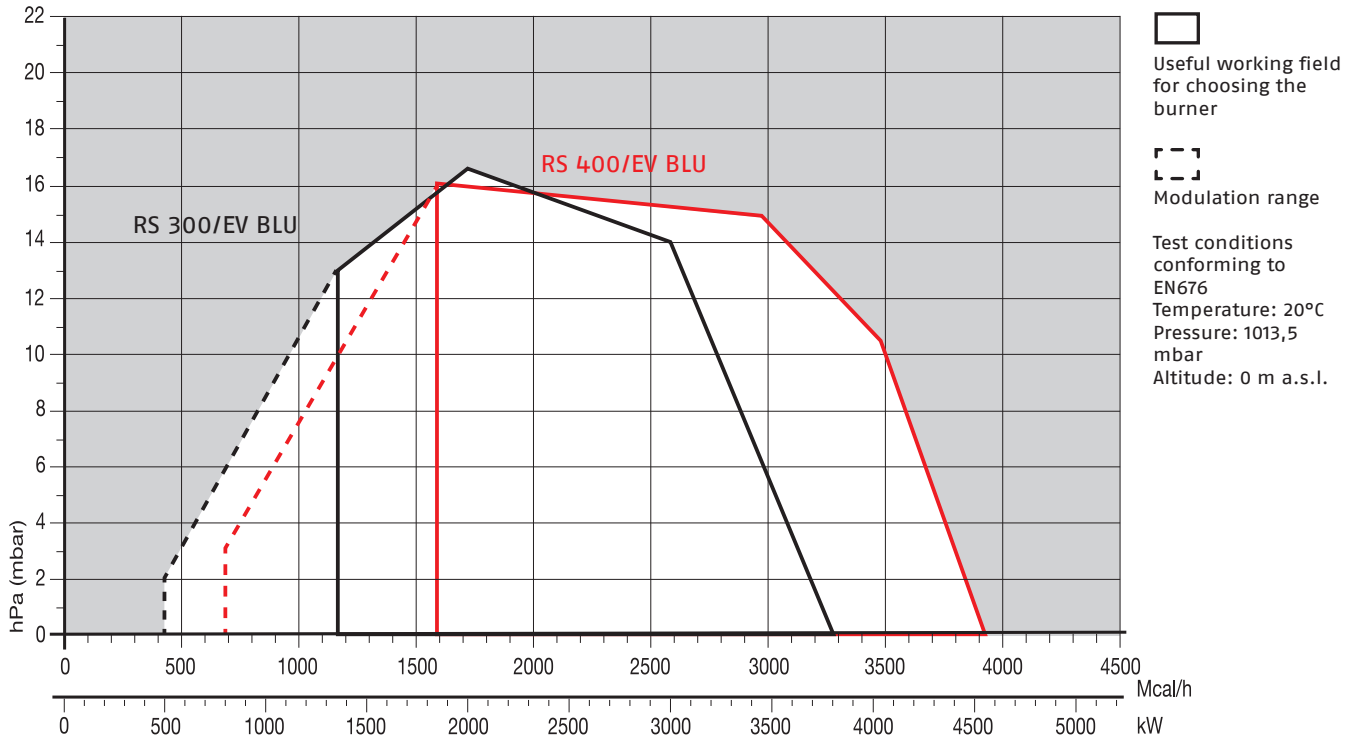

Low NOx Modulating Gas Burners

RS 300-2000/E-/EV BLU SERIES

RIELLO

FIRING RATES

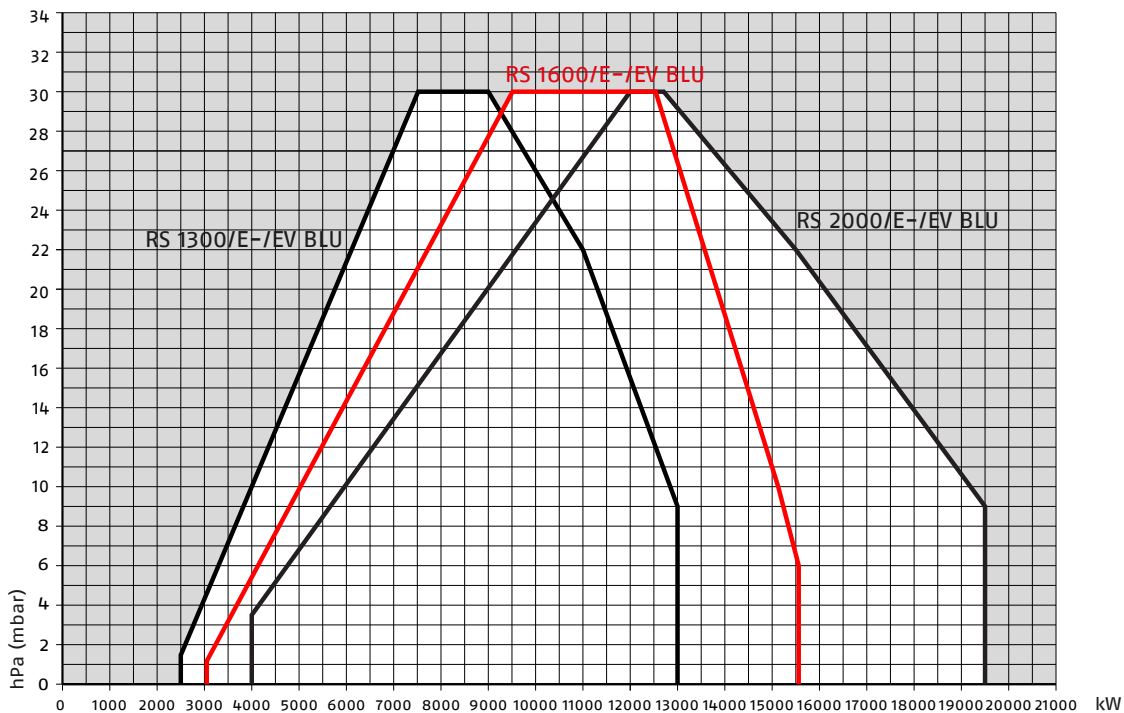
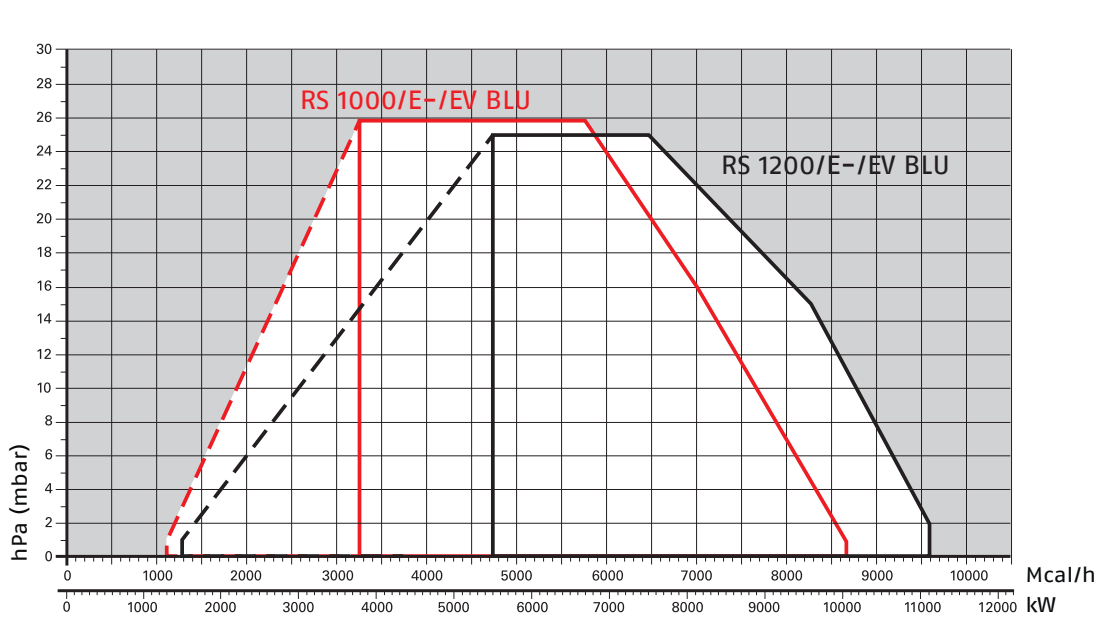

LOW NOx GAS

Low NOx Modulating Gas Burners

RS 300÷2000/E-/EV BLU SERIES

Overall dimensions (mm)

BURNER

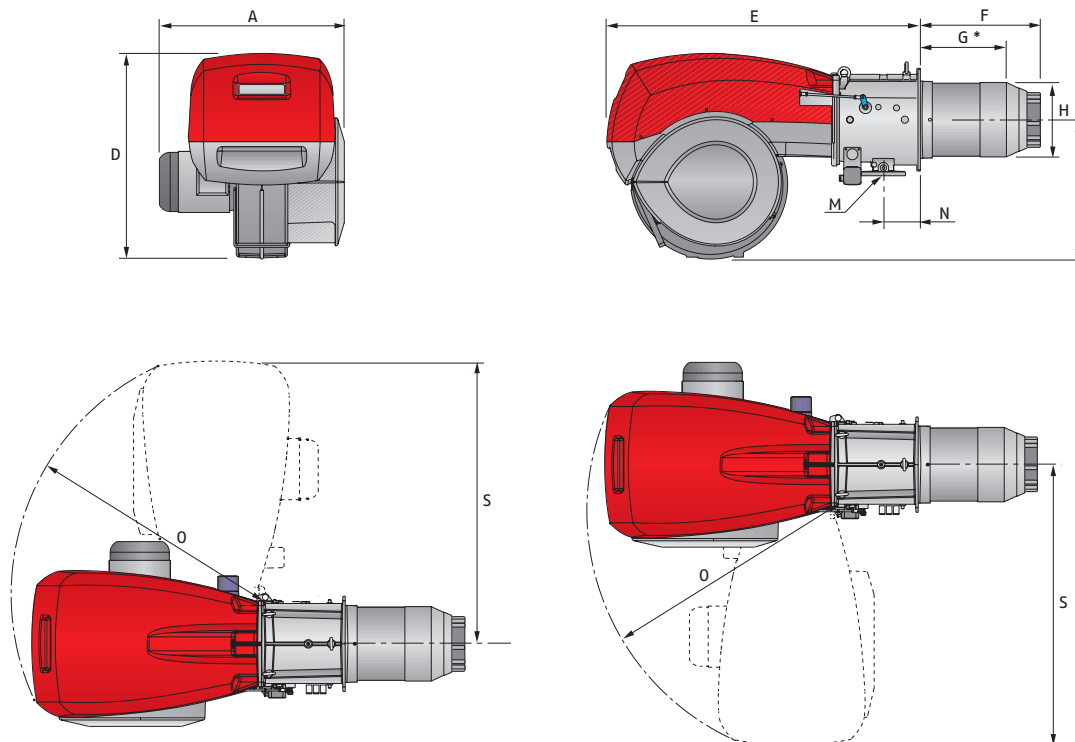

MODEL	A	D	E	F	G*	H	I	M	N	O	S
▶ RS 300/EV BLU	720	867	1325	521	373	313	588	DN65	164	1055	1175
▶ RS 400/EV BLU	775	867	1325	521	373	313	588	DN65	164	1055	1175
▶ RS 500/EV BLU	775	867	1325	521	357	370	588	DN65	164	1055	1175
▶ RS 650/EV BLU	800	950	1325	549	397	363	588	DN65/80	175	1055	1175
▶ RS 800/EV BLU	940	867	1325	582	418	363	588	DN65/80	164	1055	1175

* Maximum depth of the boiler door including the depth of the burner flange insulating gasket.

BURNER - BOILER MOUNTING FLANGE

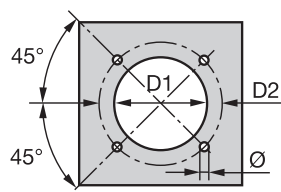

MODEL	D1	D2	Ø
▶ RS 300/EV BLU	350	452	M18
▶ RS 400/EV BLU	350	452	M18
▶ RS 500/EV BLU	390	452	M18
▶ RS 650/EV BLU	400	495	M18
▶ RS 800/EV BLU	400	495	M18

PACKAGING

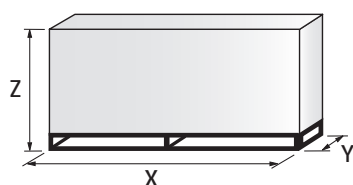

MODEL	X	Y	Z	kg
▶ RS 300/EV BLU	1960	945	1100	225
▶ RS 400/EV BLU	1960	945	1100	236
▶ RS 500/EV BLU	1960	945	1100	250
▶ RS 650/EV BLU	2040	1180	1125	300
▶ RS 800/EV BLU	2040	1180	1125	300

Overall dimensions (mm)

BURNER

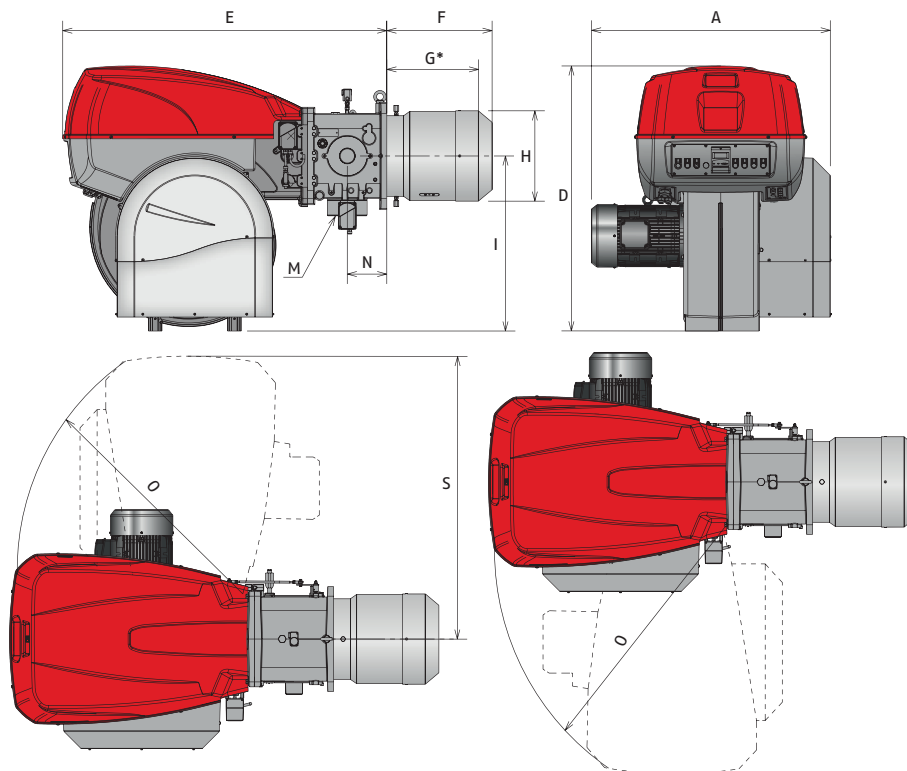

MODEL	A	D	E	F	G*	H	I	M	N	O	S
▶ RS 1000/E-EV BLU	1206	1338	1637	669	485	413	885	DN80	200	1350	1493
▶ RS 1200/E-EV BLU	1250	1338	1637	670	485	456	885	DN80	200	1350	1493

* Maximum depth of the boiler door including the depth of the burner flange insulating gasket.

BURNER - BOILER MOUNTING FLANGE

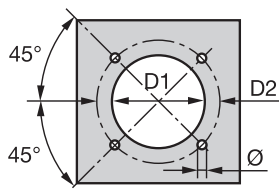

MODEL	D1	D2	Ø
▶ RS 1000/E-EV BLU	460	608	M20
▶ RS 1200/E-EV BLU	500	608	M20

PACKAGING

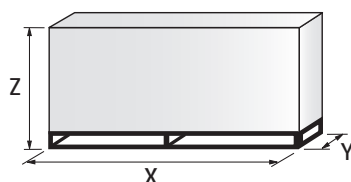

MODEL	X	Y	Z	kg
▶ RS 1000/E-EV BLU	2400	1400	1595	500
▶ RS 1200/E-EV BLU	2400	1400	1595	550

Low NOx Modulating Gas Burners

RS 300÷2000/E-/EV BLU SERIES

Overall dimensions (mm)

BURNER

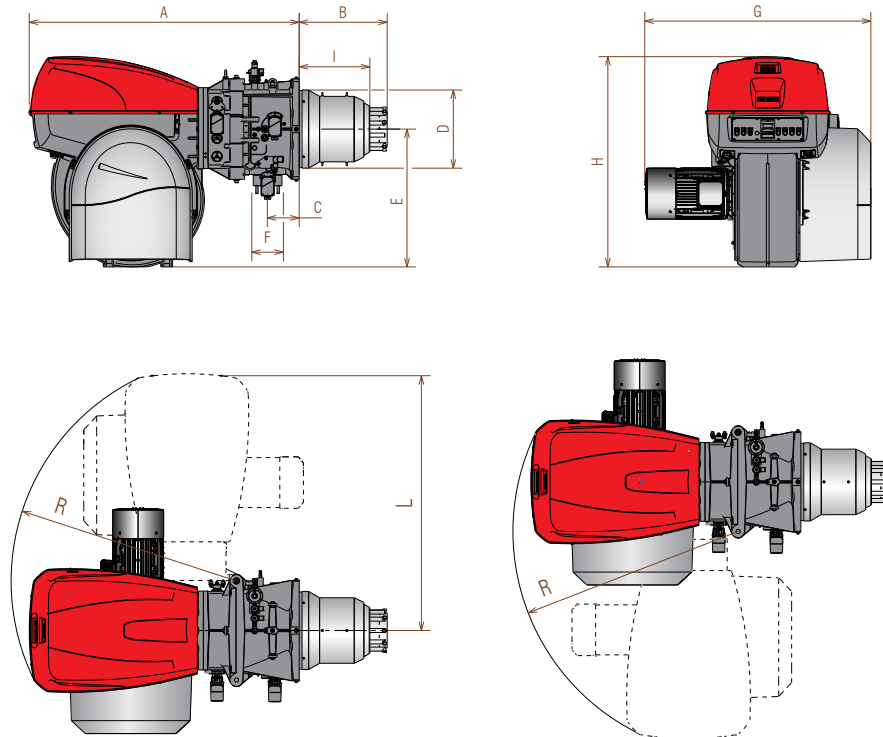

MODEL	A	B	C	D	E	F	G	H	I	L	R
▶ RS 1300/E-EV BLU	1880	613	220	544	960	DN 80	1585	1463	383	1782	1565
▶ RS 1600/E-EV BLU	1880	852	220	544	960	DN 80	1530	1463	544	1785	1565
▶ RS 2000/E-EV BLU	1880	852	220	590	960	DN 80	1560	1463	562	1782	1565

BURNER - BOILER MOUNTING FLANGE

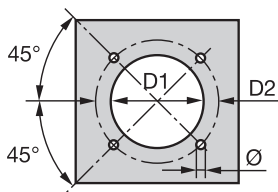

MODEL	D1	D2	Ø
▶ RS 1300/E-EV BLU	580	645	M20
▶ RS 1600/E-EV BLU	580	645	M20
▶ RS 2000/E-EV BLU	580	645	M20

PACKAGING

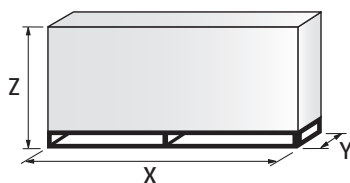

MODEL	X	Y	Z	kg
▶ RS 1300/E-EV BLU	3000	1800	1750	1180
▶ RS 1600/E-EV BLU	3000	1800	1750	1180
▶ RS 2000/E-EV BLU	3000	1800	1750	1180

Specification

DESIGNATION OF SERIES

Series: R									
Fuel: S Natural Gas									
L Light oil									
LS Light oil/Natural Gas									
N Heavy oil									
Size:									
Setting: /1 Single stage									
/B Two stage									
/M Modulating-Mechanical cam									
/E Electronic cam									
/P Proportioning air/gas valve									
/EV Electronic cam predisposed for variable speed (with inverter)									
/EVi Electronic cam with integrated inverter									
Emission: ... or C01					Class 1 EN676				
MZ					Class 2 EN676				
BLU					Class 3 EN676				
MX					Class 3 EN676				
Head length: TC standard head									
TL extended head									
Flame control system: FS1 Standard/Intermittent (at least 1 stop every 24 h)									
FS2 Continuous (1 stop every 72 h)									
Electrical supply to the system:									
1/230/50		1/230V/50Hz							
3/230/50		3/230V/50Hz							
3/400/50		3N/400V/50Hz							
3/230-400/50		3/230V/50Hz - 3N/400V/50Hz							
3/220/60		3/220V/60Hz							
3/380/60		3N/380V/60Hz							
3/220-380/60		3/220/60Hz - 3N/380V/60Hz							
Auxiliary voltage: 230/50-60					230V/50-60H				
					110/50-60 110V/50-60Hz				
R	S	1000	/E	BLU	TC	FS2	3/230-400/50	230/50-60	
BASIC DESIGNATION									
EXTENDED DESIGNATION									

Specification

STATE OF SUPPLY

RS 300-1200/E-/EV BLU

Monoblock forced draught gas burner with modulating operation, fully automatic, made up of:

- High performance fan with low sound emissions, reverse curve blades for RS 300-400-500-1000-1200, forward curve blades for RS 650
- Air suction circuit lined with sound-proofing material
- Air damper for air setting controlled by a high precision servomotor
- Air pressure switch
- Fan starting motor at 2900 rpm, three-phase 230/400 - 400/690 V with neutral, 50Hz
- Low emission mobile combustion head, that can be set on the basis of required output, fitted with:
 - stainless steel end cone, resistant to corrosion and high temperatures
 - ignition electrodes
 - flame stability disk
- Automatic regulator for gas delivery, controlled by a high precision servomotor
- Maximum gas pressure switch, with pressure test point, for halting the burner in the case of over pressure on the fuel supply line
- Module for air/fuel setting and output modulation with incorporated PID control of temperature or pressure of the heat generator
- AZL Display Interface, for combustion system commissioning and monitoring,
- Burner safety control included on Electronic Cam device
- Ionization probe for flame detector for RS 300-400-500-650 and IRD sensor or ionization probe for RS 1000-1200
- Star/delta starter for the fan motor (burners with motor electrical power $\geq 7,5$ kW, RS/E)
- Main electrical supply terminal board
- Burner on/off switch
- Auxiliary voltage led signal
- Manual or automatic output increase/decrease switch
- Burner working led signal
- Contacts motor and thermal relay with release button
- Motor internal thermal protection
- Motor failure led signal
- Burner failure led signal and lighted release button
- Emergency button
- Coded connection plugs-sockets
- Burner opening hinge
- Lifting rings
- IP 54 electric protection level
- The gas supply connector DN 80 for gas train connection (RS 300-400-500 models)

Standard equipment:

- 1 flange gasket
- 1 thermal screen
- screws for fixing the flange
- screws for fixing the burner flange to the boiler
- Seal control pressure switch (for installation on gas train)
- Instruction handbook for installation, use and maintenance
- Spare parts catalogue.

RS 300÷2000/E-/EV BLU SERIES

Specification

STATE OF SUPPLY

RS 1300-1600-2000/E-/EV BLU

Monoblock forced draught gas burner with modulating operation, fully automatic, made up of:

- High performance fan with low sound emissions, forward curve blades
- Air suction circuit lined with sound-proofing material
- Air damper for air setting controlled by a high precision servomotor
- Air pressure switch
- Fan starting motor at 2900 rpm, three-phase 400/690 V with neutral, 50Hz
- Low emission mobile combustion head, that can be set on the basis of required output, fitted with:
 - stainless steel end cone, resistant to corrosion and high temperatures
 - ignition electrodes
 - flame stability disk
 - Ignition pilot burner
- Automatic regulator for gas delivery, controlled by a high precision servomotor
- Maximum gas pressure switch, with pressure test point, for halting the burner in the case of over pressure on the fuel supply line
- Module for air/fuel setting and output modulation with incorporated PID control of temperature or pressure of the heat generator (for both RS/E and RS/EV models)
- AZL Display Interface, for combustion system commissioning and monitoring, included
- Burner safety control included on Electronic Cam device
- IRD sensor flame detector
- Star/delta starter for the fan motor
- Main terminal supply board
- Volt-free contacts output relay
- Stop/emergency push-button
- Off-automatic selector
- Light signalling of main fuel valve open
- Light signalling of mains live state
- Fan motor lockout warning lamp
- Burner lockout warning lamp and reset switch
- Heat request signal
- Fan motor contactor and thermal relay
- Burner opening hinge
- Lifting rings
- IP 54 electric protection level

Standard equipment:

- 1 flange gasket
- 1 thermal screen
- screws for fixing the flange
- screws for fixing the burner flange to the boiler
- Seal control pressure switch (for installation on gas train)
- Instruction handbook for installation, use and maintenance
- Spare parts catalogue.

Low NOx Modulating Gas Burners

RS 300÷2000/E-/EV BLU SERIES

Available models

Burners

CODE	MODEL					HEAT OUTPUT		TOTAL ELECTRICAL POWER (kW)	CERTIFICATION	NOTE
						NATURAL GAS				
						(kW)	(Nm ³ /h)			
20057514	RS 1000/E BLU	TC	FS1/FS2	3/400/50	230/50-60	1300/3800-10100	130/380-940	24	CE-0085CN0119	(1)(3)
20072967	RS 1000/E BLU	TC	FS1/FS2	3/400/50	230/50-60	1300/3800-10100	130/380-940	24	CE-0085CN0119	(1)(4)
20057515	RS 1200/E BLU	TC	FS1/FS2	3/400/50	230/50-60	1500/5500-11100	150/550-1150	27,2	CE-0085CN0120	(1)(3)
20072968	RS 1200/E BLU	TC	FS1/FS2	3/400/50	230/50-60	1500/5500-11100	150/550-1150	27,2	CE-0085CN0120	(1)(4)
20124422	RS 1300/E BLU	TC	FS1/FS2	3/400/50	230/50-60	2500/7500÷13000	250/750÷1300	34,5	-	(1)(2)(3)
20124358	RS 1600/E BLU	TC	FS1/FS2	3/400/50	230/50-60	3065/9503÷15560	307/951÷1556	41,5	-	(1)(2)(3)
20104154	RS 2000/E BLU	TC	FS1/FS2	3/400/50	230/50-60	4000/12000÷19500	400/135÷1950	49,3	-	(1)(2)(3)
3898350	RS 300/EV BLU	TC	FS1/FS2	3/230-400/50	230/50-60	500/1350÷3800	50/135÷380	5,9	CE 0085B00341	(1)(2)(4)
3898452	RS 400/EV BLU	TC	FS1/FS2	3/400/50	230/50-60	800/1840÷4550	80/184÷455	8,8	CE 0085B00341	(1)(2)(4)
3899152	RS 500/EV BLU	TC	FS1/FS2	3/400/50	230/50-60	1000/2500÷5170	100/250÷517	10,6	CE 0085B50382	(1)(2)(4)
20040547	RS 650/EV BLU	TC	FS1/FS2	3/400/50	230/50-60	1410/3000÷6500	143/300÷655	20,5	CE 0085BT0337	(1)(2)(4)(5)
3911090	RS 800/EV BLU	TC	FS1/FS2	3/400/50	230/50-60	1200/3500÷8100	120/350÷810	24	CE 0085BT0337	(1)(2)(4)(5)
20057519	RS 1000/EV BLU	TC	FS1/FS2	3/400/50	230/50-60	1300/3800-10100	130/380-940	24	CE-0085CN0119	(1)(3)(5)
20072969	RS 1000/EV BLU	TC	FS1/FS2	3/400/50	230/50-60	1300/3800-10100	130/380-940	24	CE-0085CN0119	(1)(4)(5)
20057520	RS 1200/EV BLU	TC	FS1/FS2	3/400/50	230/50-60	1500/5500-11100	150/550-1150	27,2	CE-0085CN0120	(1)(3)(5)
20072970	RS 1200/EV BLU	TC	FS1/FS2	3/400/50	230/50-60	1500/5500-11100	150/550-1150	27,2	CE-0085CN0120	(1)(4)(5)
20127213	RS 1300/EV BLU	TC	FS1/FS2	3/400/50	230/50-60	2500/7500÷13000	250/750÷1300	34,5	-	(1)(2)(3)
20104142	RS 1600/EV BLU	TC	FS1/FS2	3/400/50	230/50-60	3065/9503÷15560	307/951÷1556	41,5	-	(1)(2)(3)
20093706	RS 2000/EV BLU	TC	FS1/FS2	3/400/50	230/50-60	4000/12000÷19500	400/135÷1950	49,3	-	(1)(2)(3)

Natural gas, net calorific value: 10 kWh/Nm³ - Density: 0,71 kg/Nm³

(1) according to 2016/426/EU - 2014/35/EU - 2014/30/EU - 2014/68/EU - 2006/42 EC Directive.

(2) the burners are factory set for FS1 operation (1 stop every 24 h) but they can be switched to FS2 operation (continuous - 1 stop every 72 h) by changing the parameters through the AZL unit menu.

(3) IRD sensor

(4) ionization probe

(5) according to 2014/68/EU Pressure Equipment Directive (only FS2 version)

Low NOx Modulating Gas Burners

RS 300÷2000/E-/EV BLU SERIES

RIELLO

Available models

Gas Trains

Code	Gas train		Adapter Code		
	Model	∅	RS 300	RS 400	RS 500
3970250*	MB 415/1 – RT 52	Rp 1" 1/2	20064220 + 20064169 / (20068062) ¹	●	●
3970257*	MB 420/1 – RT 52	Rp 2"	20042324 + 20064169 / (20068062) ¹	●	●
3970221*	MBC 1200/1 – RSM 60	Rp 2"	20042324 + 20064169 / (20068062) ¹		
3970222*	MBC 1900/1 – FSM 40	DN 65	20059330 / (20065924 + 20059330) ¹ / (3010221 + 20059331) ²		
3970223*	MBC 3100/1 – FSM 40	DN 80	20059331 / (20065937 + 20059331) ¹ / (3010222 + 20059331) ²		
3970224*	MBC 5000/1 – FSM 80	DN 100	20059332 / (20065960 + 20059332) ¹ / (3010223 + 20059331) ²		
3970145*	CB 512/1 – RSM 30	Rp 1" 1/2	20064220 + 20064169 / (20068062) ¹	●	●
3970146*	CB 520/1 – RSM 30	Rp 2"	20042324 + 20064169 / (20068062) ¹		
20044659*	CB 525/1 – RSM 30	Rp 2"	20042324 + 20064169 / (20068062) ¹		
3970147*	CB 5065/1 – FSM 30	DN 65	20059330 / (20065924 + 20059330) ¹ / (3010221 + 20059331) ²		
3970148*	CB 5080/1 – FSM 30	DN 80	20059331 / (20065937 + 20059331) ¹ / (3010222 + 20059331) ²		
3970149*	CB 50100/1 – FSM 30	DN 100	20059332 / (20065960 + 20059332) ¹ / (3010223 + 20059331) ²		
20015871*	CB 50125/1 – FSM 30	DN 125	20059333 / (20065968 + 20059333) ¹ / (3010224 + 20059331) ²		

Please see designation of Gas Train Series in the page before the Catalogue index.

* 230V/50Hz – 220V/60Hz electrical supply.

The valve seal control device is compulsory (conforming to EN 676) on gas trains to burners with a maximum output over 1200 kW.

The seal control function is managed by LMV control box, by installation on gas train of a pressure switch supplied, as standard equipment with the burner.

To select the gas train please refer to the technical data leaflet and/or instruction manual.

● Not available.

□ Additional adapter not necessary, the gas train may be connected directly to the burner.

1) To be used with gas train and burner opening on the left (fan motor side).

LOW NOx GAS

Code	Gas train		Adapter Code			
	Model	∅	RS 650	RS 800	RS 1000	RS 1200
3970221*	MBC 1200/1 – RSM 60	Rp 2"	20042324 + 20064169 / (20068062) ¹		20066263 / (20065924 + 20066263) ¹	
3970222*	MBC 1900/1 – FSM 40	DN 65	20059330 / (20065924 + 20059330) ¹ / (3010221 + 20059331) ²		20066263 / (20065924 + 20066263) ¹	
3970223*	MBC 3100/1 – FSM 40	DN 80	20059331 / (20065937 + 20059331) ¹ / (3010222 + 20059331) ²		20066268 / (20065937 + 20066268) ¹	
3970224*	MBC 5000/1 – FSM 80	DN 100	20059332 / (20065960 + 20059332) ¹ / (3010223 + 20059331) ²		20066278 / (20065960 + 20066278) ¹	
20044659*	CB 525/1 – RSM 30	Rp 2"	20042324 + 20064169 / (20068062) ¹	●	20066263 / (20065924 + 20066263) ¹	●
3970147*	CB 5065/1 – FSM 30	DN 65	20059330 / (20065924 + 20059330) ¹ / (3010221 + 20059331) ²		20066263 / (20065924 + 20066263) ¹	
3970148*	CB 5080/1 – FSM 30	DN 80	20059331 / (20065937 + 20059331) ¹ / (3010222 + 20059331) ²		20066268 / (20065937 + 20066268) ¹	
3970149*	CB 50100/1 – FSM 30	DN 100	20059332 / (20065960 + 20059332) ¹ / (3010223 + 20059331) ²		20066278 / (20065960 + 20066278) ¹	
20015871*	CB 50125/1 – FSM 30	DN 125	20059333 / (20065968 + 20059333) ¹ / (3010224 + 20059331) ²		20066284 / (20065968 + 20066284) ¹	

Please see designation of Gas Train Series in the page before the Catalogue index.

* 230V/50Hz – 220V/60Hz electrical supply.

The valve seal control device is compulsory (conforming to EN 676) on gas trains to burners with a maximum output over 1200 kW.

The seal control function is managed by LMV control box, by installation on gas train of a pressure switch supplied, as standard equipment with the burner.

To select the gas train please refer to the technical data leaflet and/or instruction manual.

● Not available.

□ Additional adapter not necessary, the gas train may be connected directly to the burner.

1) To be used with gas train and burner opening on the left (fan motor side).

Low NOx Modulating Gas Burners

RS 300÷2000/E-/EV BLU SERIES

Available models

Gas Trains

Code	Gas train			CQ KIT Code	Adapter Code	
	Model	∅	◆		RS 1300	RS 1600 – 2000
3970223	MBC 3100/1 – FSM 40	DN 80	-	3010344	20130713	20130602
20093449	MBC 3100/1 CQ FSM 40	DN 80	CQ	-	20130713	20130602
3970224	MBC 5000/1 – FSM 80	DN 100	-	3010344	20130602	20130616
20093452	MBC 5000/1 CQ FSM 80	DN 100	CQ	-	20130602	20130616
3970149	CB 50100/1 – FSM 30	DN 100	-	3010344	20130602	20130616
20015871	CB 50125/1 – FSM 30	DN 125	-	3010344	20130606	20130617
20043047	DMV 50100/1 – FSM -0	DN 100	-	3010344	20130602	20130616
20043049	DMV 50100/1 CQ FSM -2	DN 100	CQ	-	20130602	20130616
20043050	DMV 50125/1 – FSM -0	DN 125	-	3010344	20130606	20130617
20043052	DMV 50125/1 CQ FSM -2	DN 125	CQ	-	20130606	20130617

Please see designation of Gas Train Series in the page before the Catalogue index.

- ◆ Gas valve leak detection control device:
- gas train not equipped with leak detection control device; this device can be ordered separately – see VPS column – and installed later.
- CQ KIT CQ gas train with pressure switch for leak detection control of burners /E and /EV.
Additional pressure switch for leak detection control in combination with burners /E and /EV.
- Gas train not available or not suitable for the matching to the burner.
- Additional adapter not necessary, the gas train may be connected directly to the burner.

Burner accessories

Extended head kit

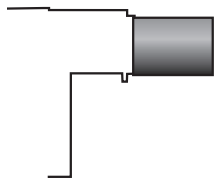

“Standard head” burners can be transformed into “extended head” versions, by using the special kit. The KITS available for the various burners, giving the original and the extended lengths, are listed below.

BURNER	STANDARD HEAD LENGTH (mm)	EXTENDED HEAD LENGTH (mm)	KIT CODE
▶ RS 300-400/EV BLU	521 (1) - 373 (2)	621 (1) - 473 (2)	3091427
▶ RS 300-400/EV BLU	521 (1) - 373 (2)	671 (1) - 523 (2)	3091919
▶ RS 300-400/EV BLU	521 (1) - 373 (2)	721 (1) - 573 (2)	20022815
▶ RS 500/EV BLU	521 (1) - 357 (2)	671 (1) - 507 (2)	20028449

(1) referred to quote F
(2) referred to quote G

Accessories for checking temperature and pressure



The temperature or pressure probes fitted to the modulating regulator must be chosen on the basis of the application.

BURNER	PROBE TYPE	RANGE (°C) (bar)	KIT CODE
▶ All models	Temperature PT 100	-100 ÷ 500°C	3010110
	Pressure 4 ÷ 20 mA	0 ÷ 2,5 bar	3010213
	Pressure 4 ÷ 20 mA	0 ÷ 16 bar	3010214
	Pressure 4 ÷ 20 mA	0 ÷ 25 bar	3090873

Sound proofing box

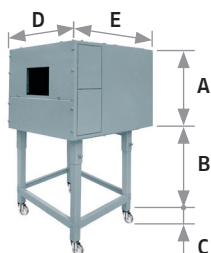

If noise emission needs reducing even further, sound-proofing boxes are available. When a lower “B” dimension is required, it is available the Box Support Kit code 20065135 which allows to reduce it at the fixed dimension of 55 mm. The sound-proofing boxes are not suitable for outdoor use.

BURNER	BOX TYPE	A (mm)	B (mm) min-max	C (mm)	D (mm)	E (mm)	[dB(A)] (*)	BOX CODE
▶ RS 300-400-500/EV BLU RS 650/EV-800/EV BLU	C7	1255	160 - 980	110	1140	1345	10	3010376
▶ RS 1000-1200/E-EV BLU	C8	1425	285 - 1000	110	1500	1800	10	3010401
▶ RS 1300-1600-2000/E-EV BLU	C9							20108736

(*) Average noise reduction according to EN 15036-1 standard

Continuous ventilation kit



If the burner requires continuous ventilation in the stages without flame, a special kit is available as given in the following table:

BURNER	KIT CODE
▶ All models	3010094

Low NOx Modulating Gas Burners

RS 300÷2000/E-/EV BLU SERIES

Burner accessories

LPG kit

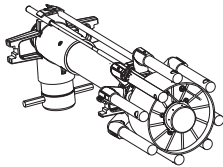

For burning LPG gas, a special kit is available to be fitted to the combustion head of the burner.

BURNER	KIT CODE
▶ RS 300/EV BLU	3010445 (*)
▶ RS 400-500/EV BLU	20012916 (*)
▶ RS 650/EV BLU	(1)
▶ RS 800/EV BLU	20007822 (*)

(*) CE approved.
(1) Not available

Spacer kit

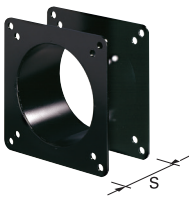

If burner head penetration into the combustion chamber needs reducing, varying thickness spacers are available, as given in the following table:

BURNER	SPACER THICKNESS S (mm)	KIT CODE
▶ RS 300-400-500-650/EV - RS 800/EV BLU	180	20008903

Variable Speed Drive (VSD) for RS/EV series only



The motor speed variation for the RS/EV BLU burners series is obtained thanks to a frequency converter: variable speed drive (VSD), provided with a programming panel with start-up assistant. It always must be ordered with RS/EV series.

BURNER	MAX POWER (kW)	KIT CODE
▶ RS 300/EV BLU	5,5	20163071
▶ RS 400/EV BLU	7,5	20163074
▶ RS 500/EV BLU	11	20163093
▶ RS 650/EV BLU	18,5	20163098
▶ RS 800-1000/EV BLU	22	20163099
▶ RS 1200-1300/EV BLU	30	20163100
▶ RS 1600/EV BLU	37	20163105
▶ RS 2000/EV BLU	45	On demand

Burner accessories

Infrared Flame Detector (IFD)

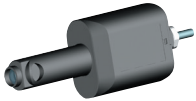

For the supervision of gas, oil or other flame that emit infrared radiation, the RS/E-EV BLU series of burners can be equipped with infrared flame detector. The infrared flame detector are suited for burners of any capacity, either in continuous or intermittent operation.

BURNER	KIT CODE
► RS 300-400-500-650-800/EV BLU	3010354

Oxygen Control kit (QGO₂) for RS/EV series only



The QGO₂ is an oxygen analyzer with relevant probe which controls and supervises the residual oxygen content in exhaust gases.

BURNER	KIT CODE
► All models	3010378
► All models	20045187*

* Installation outside the burner cover

Kit efficiency with oxygen control kit (for RS/EV only)



The kit includes two temperature sensors: one for air and one for exhaust gas detection. They must be wired to oxygen control kit interface to allow the LMV 52 efficiency calculation. The value is showed on AZL display.

BURNER	KIT CODE
► All models	3010377

PC Interface Software (ACS 450)

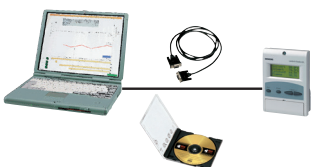

PC tool for convenient programming and burner settings, process visualization, data recording, selection of AZL language, software update AZL.

BURNER	KIT CODE
► All models	3010388



Low NOx Modulating Gas Burners

RS 300÷2000/E-/EV BLU SERIES

Gas train accessories

Adapters

In certain cases, an adapter must be fitted between the gas train and the burner, when the diameter of the gas train is different from the set diameter of the burner. Below are given the available adapters; please see on the Gas Train list the correct adapter codes to select.

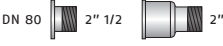
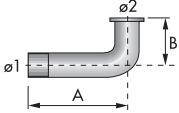
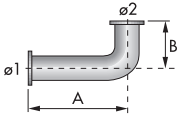
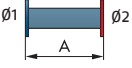
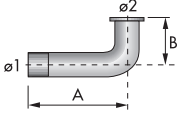
ADAPTER	DIMENSIONS				ADAPTER CODE
	Ø1 DN	Ø2 DN	A mm	B mm	
 1" 1/2" 2"	-	-	65	-	20064220
 2" 2"	-	-	65	-	20042324
 DN 80 2" 1/2" 2"	-	-	300	-	3000826
	2"	65 / 80	230	230	20064169
	2"	65 / 80	780	230	20068062
	2"	65 / 80	780	230	20068058
	65	65 / 80	230	230	20059330
	80	65 / 80	230	230	20059331
	100	65 / 80	230	230	20059332
	125	65 / 80	245	230	20059333
	2"	65 / 80	230	375	20066253
	65	65 / 80	230	375	20066263
	80	65 / 80	230	375	20066268
	100	65 / 80	230	375	20066278
	125	65 / 80	245	375	20066284
	65	80	400	-	3010221
	80	80	400	-	3010222
	100	80	400	-	3010223
	125	80	320	-	3010224
	65	65	800	-	20065924
	80	80	800	-	20065937
	100	100	800	-	20065960
	125	125	800	-	20065968
	100	100	320	174	3090680
	100	100	350	350	20130616
	125	100	320	174	309679
	125	100	350	350	20130617
	150	100	320	320	20130039
	100	80	350	350	20130602
	125	80	350	350	20130606
	80	80	350	350	20130713

Gas train accessories

Stabiliser spring



To vary the pressure range of the gas train stabilisers, accessory springs are available. The following table shows these accessories with their application range. Please refer to the technical manual for the correct choice of spring.

GAS TRAIN	SPRING COLOUR	SPRING PRESSURE RANGE mbar	SPRING CODE
▶ MBC 1900/1 - 3100/1 MBC 5000/1	White	4 - 20	3010381
	Red	20 - 40	3010382
	Black	40 - 80	3010383
	Green	80 - 150	3010384
▶ CB 512/1	Red	25 - 55	3010131
	Black	60 - 110	3010157
	Pink	90 - 150	3090486
▶ CB 520/1 - 525/1	Red	25 - 55	3010132
	Black	60 - 110	3010158
	Pink	100 - 150	3090487
▶ CB 5065/1 - 5080/1	Red	25 - 55	3010133
	Black	60 - 110	3010135
	Pink	100 - 150	3090456
▶ CB 50100/1	Grey	140 - 200	3090992
	Red	25 - 55	3010134
	Black	60 - 110	3010136
	Pink	100 - 150	3090489
▶ CB 50125/1	Grey	140 - 200	3092174
	Red	25 - 55	3010315
	Yellow	30 - 70	3010316
	Black	60 - 110	3010317
	Pink	100 - 150	3010318

PVP (Pressure Valve Proving) kit

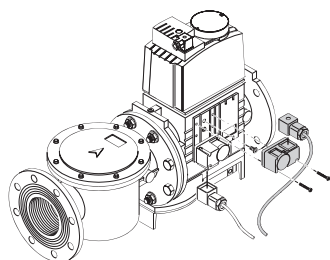

The seal control function is included on Burner Digital Management System, it is only necessary to add the PVP kit on the gas train. The PVP is included as standard equipment on RS 1300-1600-2000 models.

BURNER	KIT CODE
▶ MB - MBC - CB type	3010344

RIELLO 40 GS SERIES

The Riello 40 GS series of one stage gas burners, is a complete range of products developed to respond to any request for home heating. The Riello 40 GS series is available in four different models, with an output ranging from 11 to 220 kW, divided in four different structures.

All the models use the same components designed by Riello for the Riello 40 GS series. The high quality level guarantees safe working. The Riello 40 GS burners are fitted with a microprocessor based control box with diagnostic functions. In developing these burners, special attention was paid to reducing noise, to the ease of installation and adjustment, to obtaining the smallest size possible to fit into any sort of boiler available on the market.

All the models are approved by the EN 676 European Standard and conform to European Directives for EMC, Low Voltage, Machinery and Boiler Efficiency.

All the Riello 40 GS burners are tested before leaving the factory.

GS3	11 ÷ 35 kW
GS5	18 ÷ 58 kW
GS10	42 ÷ 116 kW
GS20	81 ÷ 220 kW

FIRING RATES

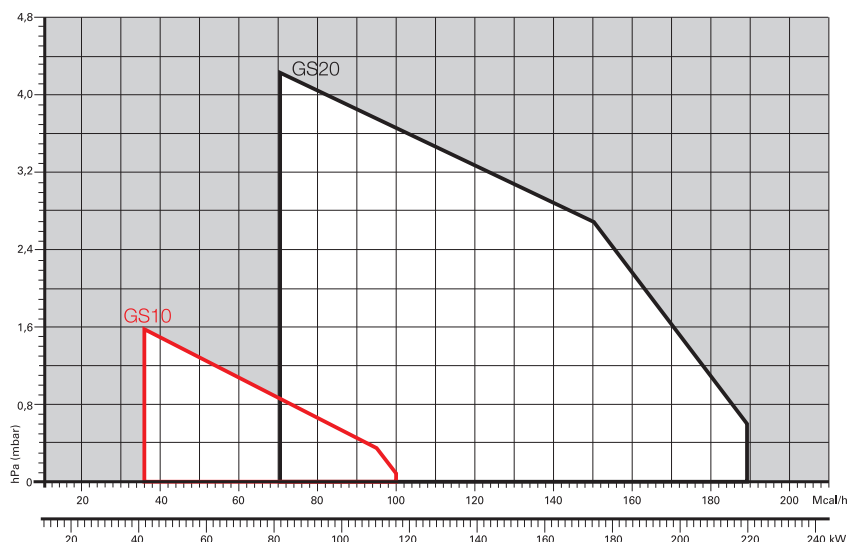
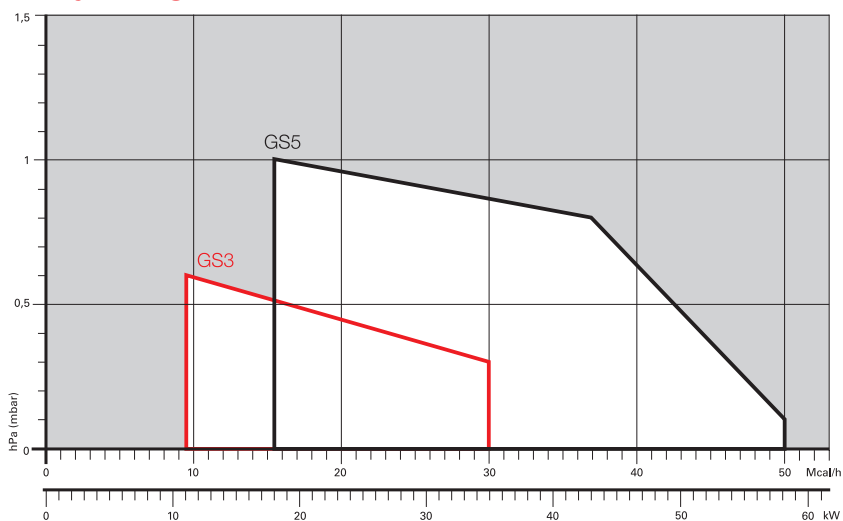

Guidelines for installation of burners in conformity to EU Regulation:

A RIELLO burner (Heat Generator), where it is matched with a water-based boiler (Heater Housing) with a nominal output ≤ 400 kW, providing heat for heating purposes and heat to deliver sanitary hot water, can be installed:

- With boilers (heater housings) already in service in the field, for replacement of identical products, in conformity to Article 1, paragraph 2, point (G) of the EU Regulation No. 813/2013;
- With boilers (heater housings) on a new installation.



Useful working field for choosing the burner

Test conditions conforming to EN676
 Temperature: 20°C
 Pressure: 1013,5 mbar
 Altitude: 0 m a.s.l.

One Stage Gas Burners

RIELLO 40 GS SERIES

Overall dimensions (mm)

BURNER

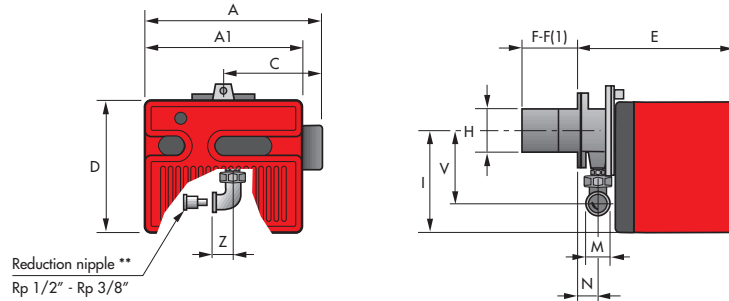

MODEL	A	A1	C	D	E	F - F(1)	H	I	M	N	V	Z
▶ GS3	-	252	-	215	230	100	91	165	Rp 3/8"*	37	132	25
▶ GS5	-	272	-	233	295	100	91	180	Rp 1/2"	48	138	28
▶ GS10	341	-	188,5	262	346	110	105	204	Rp 3/4"	61	142	33
▶ GS10 ***	-	305	-	262	346	110 - 170	105	204	Rp 3/4"	61	142	33
▶ GS20	387	-	212	298	389	120 - 280	125	230	Rp 3/4"	67	152	33
▶ GS20 ***	-	350	-	298	389	120	125	230	Rp 3/4"	67	152	33

* With reduction nipple

** Standard equipment on R40 GS3

*** Versions with air damper opening motor inside the cover

(1) dimension with extended head

BURNER - BOILER MOUNTING FLANGE

GS3 - GS5 - GS10

GS20

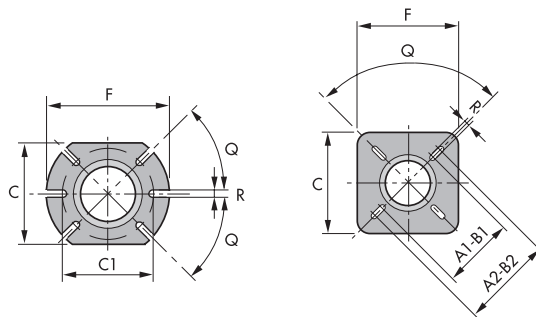

MODEL	A1	A2	B1	B2	C	C1	F	Q	R
▶ GS3	-	-	-	-	140	130	170	45°	10
▶ GS5	-	-	-	-	140	130	170	45°	10
▶ GS10	-	-	-	-	160	130	185	45°	11
▶ GS20	155	200	155	200	170	-	170	90°	11

PACKAGING

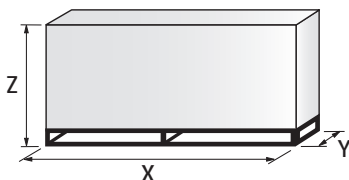

MODEL	X	Y	Z	kg
▶ GS3	375	335	310	11
▶ GS5	445	355	325	11
▶ GS10	483	423	330	15
▶ GS20	535	463	375	21

Specification

DESIGNATION OF SERIES

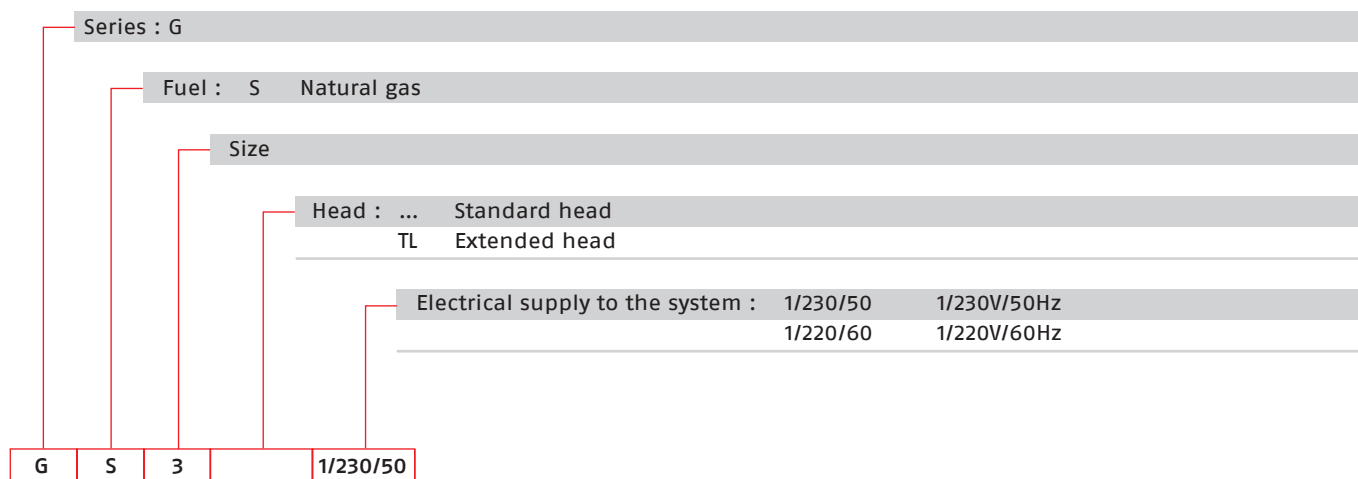

STATE OF SUPPLY

Monoblock, gas burners, completely automatic, with one stage settings fitted with:

- Fan with forward curve blades
- Cover lined with sound-proofing material
- Air damper, completely closed in stand by, with adjustment inside the cover
- Single phase electric motor 230 V, 50 Hz
- Combustion head fitted with:
 - stainless steel head cone, resistant to high temperatures
 - ignition electrodes
 - ionisation probe
 - gas distributor
 - flame stability disk
- Adjustable air pressure switch, with graduated selector, to guarantee burner lock out in the case of insufficient combustible air
- Microprocessor-based burner safety control box MG 557 (with diagnostic, remote reset, continuous purge integrated, recycle, post-purge)
- IP X0D (IP 40) electric protection level.

Standard equipment:

- Flange insulation screen
- Screws and nuts for fixing the flange to the boiler
- 7-pole socket
- Hinge
- Reduction nipple Rp 1/2" - Rp 3/8" (for R40 GS3 only)
- Grommet
- Instruction handbook for installation, use and maintenance
- Spare parts catalogue.

One Stage Gas Burners

RIELLO 40 GS SERIES

Available models

Burners

CODE	MODEL	HEAT OUTPUT		TOTAL ELECTRICAL POWER (kW)	CERTIFICATION	NOTE
		(kW)	NATURAL GAS (Nm ³ /h)			
3755119	GS3 1/230/50	11 - 35	1,1 - 3,5	0,100	CE-0476CT2714	(1) (5)
3755219	GS5 1/230/50	18 - 58	1,8 - 5,8	0,110	CE-0476CT2714	(1) (5)
3755281	GS5 1/220/60	23 - 65	2,3 - 6,5	0,180	-	(2) (4) (5)
3755426	GS10 1/230/50	42 - 116	4,2 - 11,6	0,130	CE-0476CT2714	(1)
3755483	GS10 1/220/60	42 - 116	4,2 - 11,6	0,200	-	(2) (4)
20007527	GS10 1/220/60	42 - 116	4,2 - 11,6	0,200	-	(1) (4) (5)
3755616	GS20 1/230/50	81 - 220	8,1 - 22	0,250	CE-0476CT2714	(1)
3755683	GS20 1/220/60	81 - 220	8,1 - 22	0,430	-	(2) (4) (5)

Net calorific value G20: 10 kWh/Nm³ - Density: 0,71 kg/Nm³

The burners of GS series are in according to EN 676

(1) With plug and socket

(2) With terminal block

(4) Korea version

(5) With air damper opening motor inside the cover

Gas Trains

	GAS TRAIN CODE *	GAS TRAIN MODEL	NATURAL GAS		LPG		NOTE
			BURNER (type)	ADAPTER (code)	BURNER (type)	ADAPTER (code)	
MULTIBLOC GAS TRAIN	3970569	MBC 65/1 - RSD 20	GS3 - GS5		GS3 - GS5		(1)
	3970530	MB 405/1 - RSD 20	GS5 - GS10		GS5 - GS10		(1)
	3970531	MB 407/1 - RSD 20	GS5 - GS10 - GS20		GS5 - GS10 - GS20		(1) (3)
	3970532	MB 410/1 - RSD 20	GS10 - GS20		GS10 - GS20		(1)

Please see Designation of Gas Train Series in the page before the Catalogue index.

* Gas train are 230V/50Hz - 220V/60Hz electrical supply

(1) With installed plug (if the plug is not necessary, remove it in accordance with gas train instruction manual indication)

(2) GS10 ≤ 80 kW with natural gas

(3) GS20 ≤ 180 kW with natural gas

The valve seal control device is compulsory (conforming to EN 676) on gas trains to burners with a maximum output over 1200 kW.

To select the gas train please refer to the technical data leaflet and/or instruction manual.

Burner accessories

Extended head kit

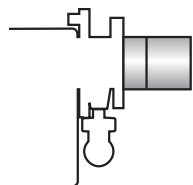

"Standard head" burners can be transformed into "extended head" versions by using the special kit. Below the KITS available for the various burners are listed, showing the original and the extended lengths.

BURNER	STANDARD HEAD LENGTH (mm)	EXTENDED HEAD LENGTH (mm)	KIT CODE
▶ GS3 - GS5	100	125	3000820
▶ GS10	110	170	3001064
▶ GS20	120	280	3000873

Remote reset control kit for MG 557 control box

The MG 557 control box can be remotely released using an electric command kit. This kit must be installed in conformity with current regulations in force.

BURNER	KIT CODE
▶ GS3 - GS5	3002750

LPG kit

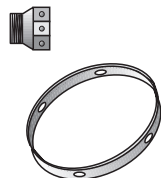

For burning LPG gas, a special kit is available to be fitted to the combustion head on the burner as shown in the following table.

BURNER	KIT CODE FOR STANDARD HEAD	KIT CODE FOR EXTENDED HEAD
▶ GS3	3000881	3000881
▶ GS5	3000882	3000882
▶ GS10	3000884	3000884
▶ GS20	3000886	3000886

Town gas kit

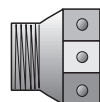

BURNER	KIT CODE
▶ GS3	3000888
▶ GS5	3000889
▶ GS10	3000891
▶ GS20	3000893

Inlet air aspiration kit

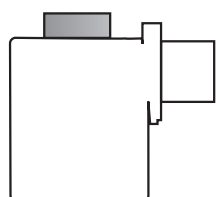

This kit allows to channel the external air directly into the burner and is available as accessory for models:

BURNER	KIT CODE
▶ GS3	20027571
▶ GS5	20027576
▶ GS10	20027578
▶ GS20	20027581

One Stage Gas Burners

RIELLO 40 GS SERIES

Burner accessories

End cone with turbulator disk

The end cone turbulator disk reduces the flame length. It is suitable for hoven application (CO emissions) and short boiler chamber.

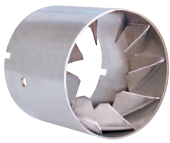

BURNER	PROJECTION (mm)	KIT CODE
▶ GS5	+15	3000916
▶ GS10	+18	3000918
▶ GS20	+23	3000919

Ground fault interrupter kit



A "Ground fault interrupter kit" is available as a safety device in case of electrical system fault. It is supplied with burners with pin plug.

BURNER	KIT CODE
▶ GS3 - GS5 - GS10 - GS20	3001180

7-pin plug kit

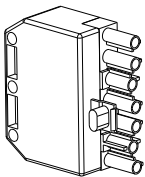

If necessary a 7-pin plug kit is available (in packaging of n. 5 pieces).

BURNER	KIT CODE
▶ GS3 - GS5 - GS10 - GS20	3000945

Continuous ventilation kit for RMG control box

If the burner requires continuous ventilation in the stages without flame, a special kit is available as given in the following table.

BURNER	KIT CODE
▶ GS10 - GS20	3010094

PC interface kit



To connect the RMG control box to a personal computer for the transmission of operation, fault signals and detailed service information, an interface adapter with PC software are available.

BURNER	KIT CODE
▶ GS10 - GS20	3002719

Gas train accessories

Seal control kit



To test the valve seals on the gas train, (except for the model with Multibloc MBC 65 DLE) a special "seal control kit" is available.

GAS TRAIN	KIT CODE for 50 Hz operation	KIT CODE for 60 Hz operation
▶ MB/1 type	3010123	20168805

RIELLO 40 GSD SERIES

The Riello 40 GSD series of two stage gas burners, is a complete range of products developed to respond to any request for home heating. The Riello 40 GSD series is available in two different models, with an output ranging from 41 to 220 kW, divided in two different structures.

All the models use the same components designed by Riello for the Riello 40 GSD series. The high quality level guarantees safe working.

In developing these burners, special attention was paid to reducing noise, to the ease of installation and adjustment, to obtaining the smallest size possible to fit into any sort of boiler available on the market.

All the models are approved by the EN 676 European Standard and conform to European Directives for EMC, Low Voltage, Gas Appliance and Boiler Efficiency.

All the Riello 40 GSD burners are tested before leaving the factory.

Guidelines for installation of burners in conformity to EU Regulation:

A RIELLO burner (Heat Generator), where it is matched with a water-based boiler (Heater Housing) with a nominal output ≤ 400 kW, providing heat for heating purposes and heat to deliver sanitary hot water, can be installed:

- With boilers (heater housings) already in service in the field, for replacement of identical products, in conformity to Article 1, paragraph 2, point (G) of the EU Regulation No. 813/2013;
- With boilers (heater housings) on a new installation.



GS10D	29/41 ÷ 106 kW
GS20D	58/81 ÷ 220 kW

FIRING RATES

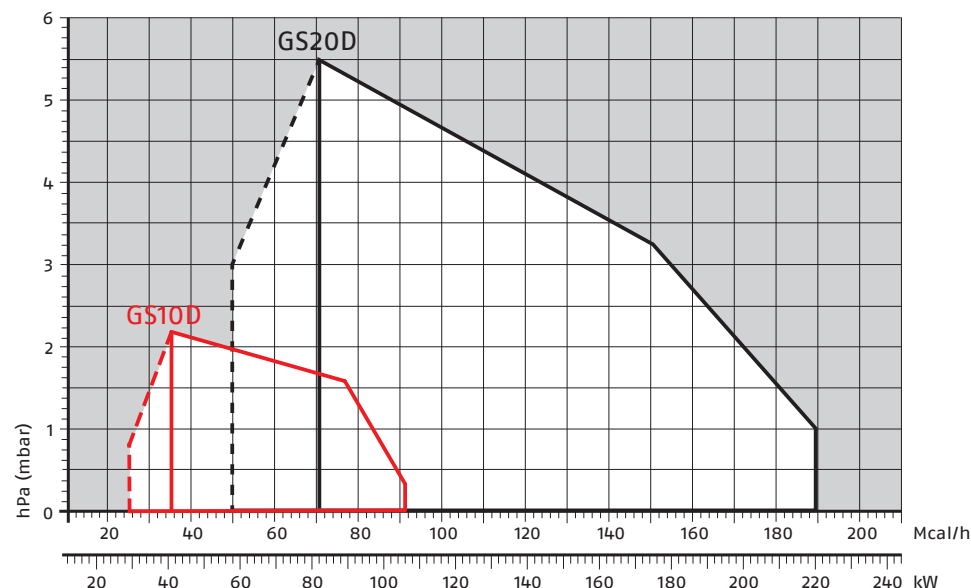

Useful working field for choosing the burner



1st stage operation range

Test conditions conforming to EN676
 Temperature: 20°C
 Pressure: 1013,5 mbar
 Altitude: 0 m a.s.l.

Two Stage Gas Burners

RIELLO 40 GSD SERIES

Overall dimensions (mm)

BURNER

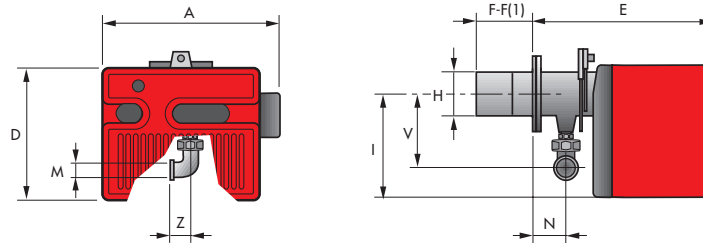

MODEL	A	D	E	F - F(1)	H	I	M	N	V	Z
▶ GS10D	368	262	346	110	105	204	Rp 3/4"	61	142	33
▶ GS20D	413	298	389	120 - 280	125	230	Rp 3/4"	67	152	33

(1) dimension with extended head

BURNER - BOILER MOUNTING FLANGE

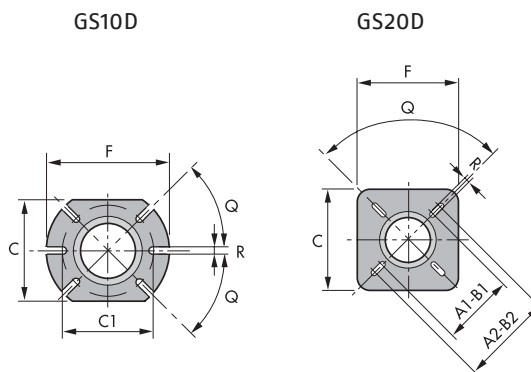

MODEL	A1	A2	B1	B2	C	C1	F	Q	R
▶ GS10D	-	-	-	-	160	130	185	45°	11
▶ GS20D	155	200	155	200	170	-	170	90°	11

PACKAGING

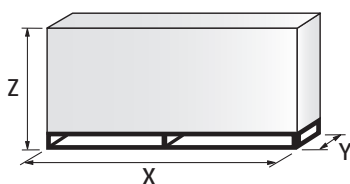

MODEL	X	Y	Z	kg
▶ GS10D	495	483	330	16
▶ GS20D	535	535	375	22

Specification

DESIGNATION OF SERIES

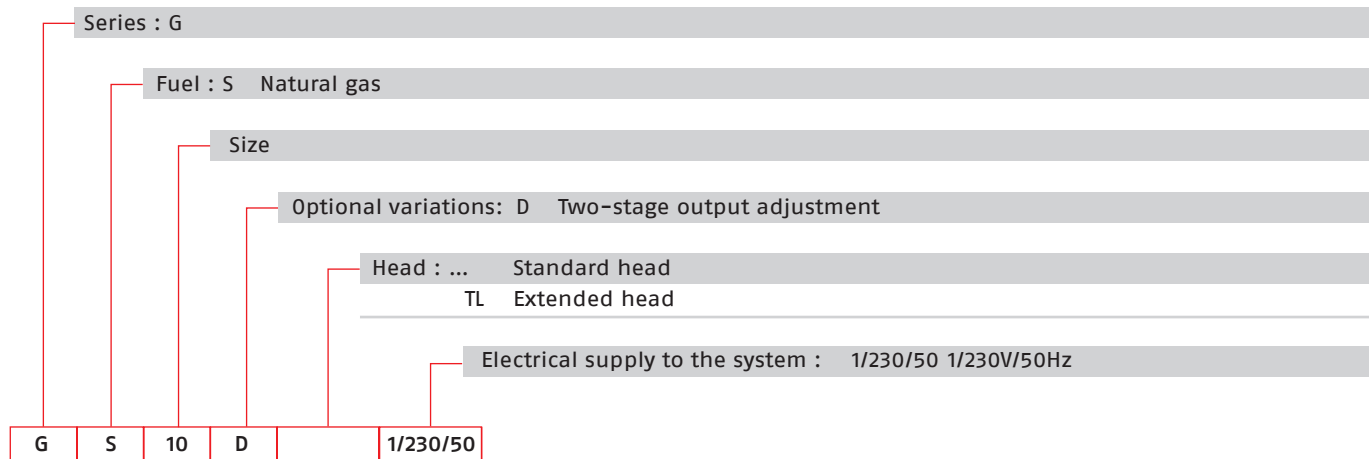

STATE OF SUPPLY

Burner:

Monoblock, gas burners, completely automatic, two stage operation, made up of:

- Fan with forward curve blades
- Cover lined with sound-proofing material
- Air damper, completely closed in stand by, driven by an electric servomotor
- Air damper with 1st and 2nd stage adjustment
- Single phase electric motor 230 V, 50 Hz
- Combustion head fitted with:
 - stainless steel head cone, resistant to high temperatures
 - ignition electrodes
 - ionisation probe
 - gas distributor
 - flame stability disk
 - flame inspection window
- Adjustable air pressure switch, with graduated selector, to guarantee burner lock out in the case of insufficient combustible air
- Protection filter against radio interference
- IP X0D (IP 40) electric protection level.

Standard equipment:

- Flange insulation screen
- Screws and nuts for fixing the flange to the boiler
- 7-pole socket
- 4-pole socket
- Hinge
- Grommet
- Instruction handbook for installation, use and maintenance
- Spare parts catalogue.

Two Stage Gas Burners

RIELLO 40 GSD SERIES

Available models

Burners

CODE	MODEL	HEAT OUTPUT		TOTAL ELECTRICAL POWER (kW)	CERTIFICATION	NOTE
		(kW)	NATURAL GAS (Nm ³ /h)			
3757615	GS10D 1/230/50	29/41 - 106	2,9/4,1 - 10,6	0,130	CE-0476CT2714	(1)
3757714	GS20D 1/230/50	58/81 - 220	5,8/8,1 - 22	0,250	CE-0476CT2714	(1)

Net calorific value G20: 10 kWh/Nm³ - Density: 0,71 kg/Nm³
 The burners of GSD series are in according to EN 676
 (1) With plug and socket.

Gas Trains

MULTIBLOC GAS TRAINS	GAS TRAIN CODE *	GAS TRAIN MODEL	NATURAL GAS		LPG		NOTE
			BURNER (type)	ADAPTER (code)	BURNER (type)	ADAPTER (code)	
	3970084	MB 405/2 - RSD 20	GS10D		GS10D		(1) (2)
	3970537	MB 407/2 - RSD 20	GS10D - GS20D		GS10D - GS20D		(1) (3)
	3970534	MB 410/2 - RSD 20	GS20D		GS20D		(1)

Please see Designation of Gas Train Series in the page before the Catalogue index.

* Gas train are 230V/50Hz - 220V/60Hz electrical supply

(1) With installed plug

(2) GS10D ≤ 80 kW with natural gas

(3) GS20D ≤ 180 kW with natural gas

The valve seal control device is compulsory (conforming to EN 676) on gas trains to burners with a maximum output over 1200 kW.

To select the gas train please refer to the technical data leaflet and/or instruction manual.

Burner accessories

Extended head kit

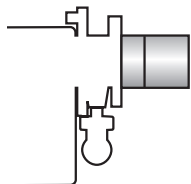

Burners "standard head" can be transformed into "extended head" versions by using the special kit. Here the KITS available for the various burners are listed, showing the original and the extended lengths.

BURNER	STANDARD HEAD LENGTH (mm)	EXTENDED HEAD LENGTH (mm)	KIT CODE
▶ GS10D	100	170	3001064
▶ GS20D	120	280	3000873

End cone with turbulator disk



The end cone turbulator disk reduces the flame length. It is suitable for hoven application (CO emissions) and short boiler chamber.

BURNER	PROJECTION (mm)	KIT CODE
▶ GS10D	+18	3000918
▶ GS20D	+23	3000919

LPG kit

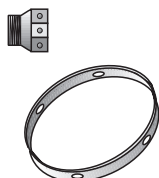

For burning LPG gas, a special kit is available to be fitted to the combustion head on the burner as shown in the following table.

BURNER	KIT CODE FOR STANDARD HEAD	KIT CODE FOR EXTENDED HEAD
▶ GS10D	3000884	3000884
▶ GS20D	3000886	3000886

Town gas kit

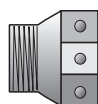

BURNER	KIT CODE
▶ GS10D	3000891
▶ GS20D	3000894

Ground fault interrupter kit



A "Ground fault interrupter kit" is available as a safety device in case of electrical system fault. It is supplied with burners with pin plug.

BURNER	KIT CODE
▶ GS10D - GS20D	3001180

Two Stage Gas Burners

RIELLO 40 GSD SERIES

Burner accessories

7-pin plug kit

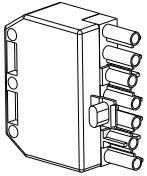

If necessary a 7-pin plug kit is available (in packaging of n. 5 pieces).

BURNER	KIT CODE
► GS10D – GS20D	3000945

Continuous ventilation kit for RMG control box

If the burner requires continuous ventilation in the stages without flame, a special kit is available as given in the following table.

BURNER	KIT CODE
► GS10D – GS20D	3010094

PC interface kit



To connect the RMG control box to a personal computer for the transmission of operation, fault signals and detailed service information, an interface adapter with PC software are available.

BURNER	KIT CODE
► GS10D – GS20D	3002719

Gas train accessories

Seal control kit



To test the valve seals on the gas train a special "seal control kit" is available.

GAS TRAIN	KIT CODE for 50 Hz operation	KIT CODE for 60 Hz operation
► MB/1 type	3010123	20168805

RIELLO 40 GS/M SERIES

The Riello 40 GS/M series of two stage progressive or modulating gas burners, is a complete range of products developed to respond to any request of gas burners for hot air generator according to EN 1020. These new models complete the Riello 40 gas series which prides itself on many years of experience in all the world in the field of residential heating and soft industrial applications. This series of burners is available in two different models with an output ranging from 42 to 194 kW, divided in two different structures. Basic version of these models has two stage progressive operation. A simple modification, adding a component, permits obtaining modulating operation with a rate 1:4. The burners are supplied air fuel ratio control gas trains.

This more advanced version can better satisfy market needs for applications where modulation is requested to obtain highest plant efficiency. In developing these burners, special attention was paid to the ease of installation and adjustment, to maintaining the smallest size possible and obtaining high performance for modulating operation to fit into any sort of application available on the market. All the models are approved by the EN 676 European Standard and they conform to European Directives: Gas Appliances, EMC, Low Voltage and Boiler Efficiency.

Guidelines for installation of burners in conformity to EU Regulation:

A RIELLO burner (Heat Generator), where it is matched with a water-based boiler (Heater Housing) with a nominal output ≤ 400 kW, providing heat for heating purposes and heat to deliver sanitary hot water, can be installed:

- With boilers (heater housings) already in service in the field, for replacement of identical products, in conformity to Article 1, paragraph 2, point (G) of the EU Regulation No. 813/2013;
- With boilers (heater housings) on a new installation.



GS 10/M	22 / 42 ÷ 105 kW
GS 20/M	43 / 82 ÷ 194 kW

Two Stage Progressive and Modulating Gas Burners

RIELLO 40 GS/M SERIES

FIRING RATES

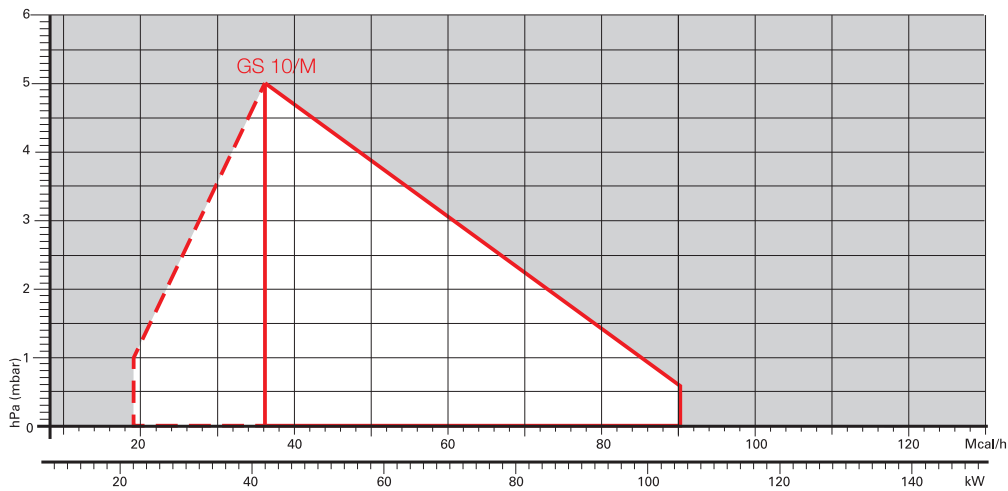

□ Useful working field for choosing the burner

▭ Modulation range

Test conditions conforming to EN676
 Temperature: 20°C
 Pressure: 1013,5 mbar
 Altitude: 0 m a.s.l.

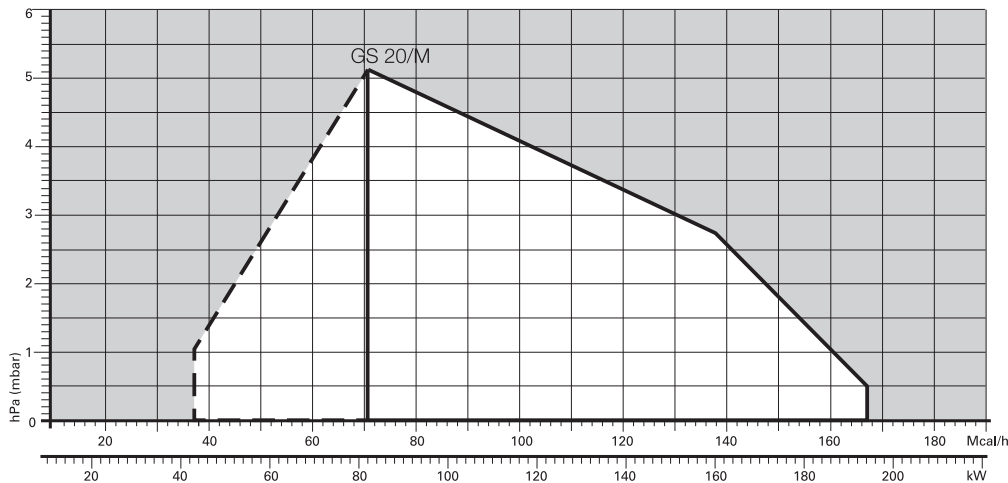

Overall dimensions (mm)

BURNER

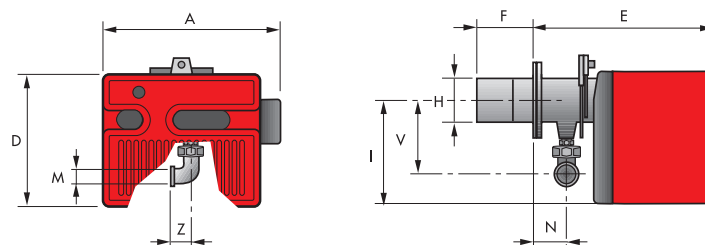

MODEL	A	D	E	F	H	I	M	N	V	Z
▶ GS10/M	425	262	347	110	105	204	Rp 3/4"	61	142	33
▶ GS20/M	488	298	389	120	125	230	Rp 3/4"	67	152	33

Two Stage Progressive and Modulating Gas Burners

RIELLO 40 GS/M SERIES

RIELLO

BURNER - BOILER MOUNTING FLANGE

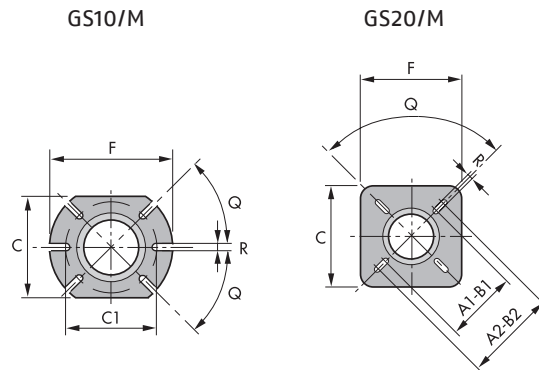

MODEL	A1	A2	B1	B2	C	C1	F	Q	R
▶ GS10/M	-	-	-	-	160	130	185	45°	11
▶ GS20/M	155	200	155	200	170	-	170	90°	11

PACKAGING

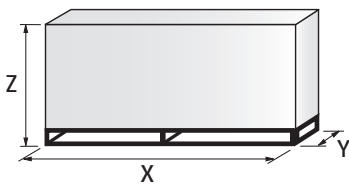

MODEL	X	Y	Z	kg
▶ GS10/M	505	490	330	17
▶ GS20/M	560	535	375	17

Specification

DESIGNATION OF SERIES

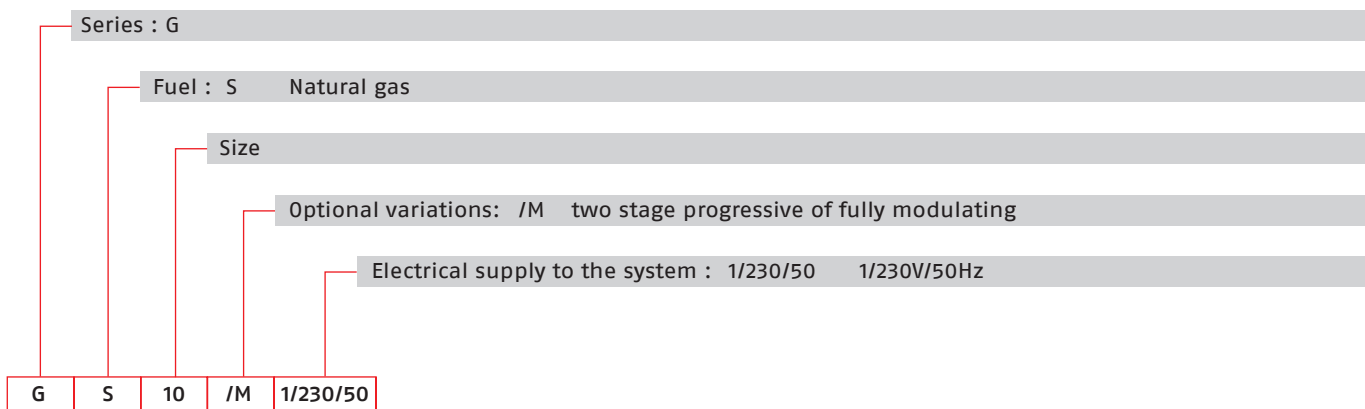

GAS

Two Stage Progressive and Modulating Gas Burners

RIELLO 40 GS/M SERIES

STATE OF SUPPLY

- Monoblock, gas burners, completely automatic, two stage progressive or modulating operation with a kit, made up of:
- Ratio air/fuel controlled by checking both the air and the gas flows
 - Two pressure switches on the burner, to make sure the burner operation, detecting both the fan and the chimney functions
 - Remote reset available
 - Servomotor to drive the air damper to fully closed position at stand-by, low and high fire position
 - Turn down fire 1:4
 - Fan with forward curve blades
 - Single phase electric motor 230 V, 50 Hz
 - Combustion head fitted with:
 - stainless steel head cone, resistant to high temperatures
 - ignition electrodes
 - ionisation probe
 - gas distributor
 - flame stability disk
 - additional device, to keep short the flame shape
 - Protection filter against radio interference
 - Microprocessor-based flame control box, with diagnostic functions
 - IP X0D (IP 40) electric protection level.

Standard equipment:

- Hinge to turn the burner left-side or right-side for the maintenance position
- Flange insulation screen
- Screws and nuts for fixing the flange to the boiler
- 7-pin plug with capacitor for EMC
- 4-pin plug to connect the high-low thermostat
- Instruction handbook for installation, use and maintenance
- Spare parts catalogue.

Available models

Burners

CODE	MODEL	HEAT OUTPUT		TOTAL ELECTRICAL POWER (kW)	CERTIFICATION	NOTE
		NATURAL GAS (kW)	NATURAL GAS (Nm ³ /h)			
3755556	GS10/M 1/230/50	22/42 - 105	2,2/4,2 - 10,5	0,130	CE - 0085 BM0453	(1)
3755756	GS20/M 1/230/50	43/82 - 194	4,3/8,2 - 19,4	0,250	CE - 0085 BM0453	(1)
20066426	GS10/M 1/220/60	22/42 - 105	2,2/4,2 - 10,5	0,130	-	(1)
3091960	GS20/M 1/220/60	43/82 - 194	4,3/8,2 - 19,4	0,250	-	(1)

(1) With installed plug.

Net calorific value G20 gas: 10 kWh/Nm³; 8600 kcal/Nm³ - Density: 0,71 kg/Nm³.

Gas Trains

MULTIBLOC GAS TRAINS	GAS TRAIN CODE *	GAS TRAIN MODEL	NATURAL GAS		LPG		NOTE
			BURNER (type)	ADAPTER (code)	BURNER (type)	ADAPTER (code)	
	3970535	MB 407/P - RSD 00	GS10/M		GS10/M		(1)
			GS20/M		GS20/M		
	3970536	MB 412/P - RSD 00	GS20/M		GS20/M		(1) (2)

Please see Designation of Gas Train Series in the page before the Catalogue index.

* Gas train are 230V/50Hz - 220V/60Hz electrical supply

(1) With plug and socket.

(2) ≥120 kW.

The valve seal control device is compulsory (conforming to EN 676) on gas trains to burners with a maximum output over 1200 kW.

To select the gas train please refer to the technical data leaflet and/or instruction manual.

RIELLO 40 GS/M SERIES

Burner accessories

Extended head kit

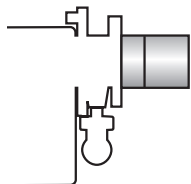

Burners "standard head" can be transformed into "extended head" versions by using the special kit. Here the KITS available for the various burners are listed, showing the original and the extended lengths.

BURNER	STANDARD HEAD LENGTH (mm)	EXTENDED HEAD LENGTH (mm)	KIT CODE
▶ GS10/M	128	170	3001064
▶ GS20/M	120	280	3000873

LPG kit



For burning LPG gas, a special kit is available to be fitted to the combustion head on the burner as shown in the following table.

BURNER	KIT CODE FOR STANDARD HEAD	KIT CODE FOR EXTENDED HEAD
▶ GS10/M	3000884	3000884
▶ GS20/M	3000886	3000886

Ground fault interrupter kit



A "Ground fault interrupter kit" is available as a safety device in case of electrical system fault. It is supplied with burners with pin plug.

BURNER	KIT CODE
▶ GS10/M – GS20/M	3001180

7-pin plug kit

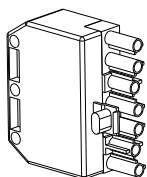

If necessary a 7-pin plug kit is available (in packaging of n. 5 pieces).

BURNER	KIT CODE
▶ GS10/M – GS20/M	3000945

Two Stage Progressive and Modulating Gas Burners

RIELLO 40 GS/M SERIES

Burner accessories

Accessories for modulating operation



To obtain modulating operation, the GS/M series of burners requires a regulator.

BURNER	REGULATOR TYPE	REGULATOR CODE
► GS10/M – GS20/M	RWF 50.2	20105193
	RWF 50.5	20105274



The relative temperature or pressure probes fitted to the regulator, must be chosen on the basis of the application.

BURNER	PROBE TYPE	RANGE (°C) (bar)	PROBE CODE
► GS10/M – GS20/M	Temperature PT 100	-100 ÷ 500°C	3010110
	Pressure 4 ÷ 20 mA	0 ÷ 2,5 bar	3010213
	Pressure 4 ÷ 20 mA	0 ÷ 16 bar	3010214

PC interface kit



To connect the RMG control box to a personal computer for the transmission of operation, fault signals and detailed service information, an interface adapter with PC software are available.

BURNER	KIT CODE
► GS10/M – GS20/M	3002719

GULLIVER RS SERIES

The Riello Gulliver RS5 is a new model of the series of one stage gas burners, characterized for its small dimensions in spite of its high combustion performance. It has been developed to respond to any request for home heating, conforming to current regulations in force.

This model uses the same components designed by Riello for the Gulliver series. The high quality level guarantees safe working.

The burners are fitted with a microprocessor-based burner safety control box which supplies indication of operation and diagnosis of fault cause.

In developing this burner, special attention was paid to reducing noise, the ease of installation and adjustment, to obtaining the smallest size possible to fit into any sort of boiler available on the market.

This model is approved by the EN 676 European Standard and European Directives, Gas Appliance, EMC, Low Voltage, Boiler Efficiency.

The Gulliver RS5 burner is tested before leaving the factory. **Guidelines for installation of burners in conformity to EU Regulation:**

A RIELLO burner (Heat Generator), where it is matched with a water-based boiler (Heater Housing) with a nominal output ≤ 400 kW, providing heat for heating purposes and heat to deliver sanitary hot water, can be installed:

- With boilers (heater housings) already in service in the field, for replacement of identical products, in conformity to Article 1, paragraph 2, point (G) of the EU Regulation No. 813/2013;
- With boilers (heater housings) on a new installation.



RS5	160 ÷ 330 kW
RS5 TL	160 ÷ 330 kW

FIRING RATES

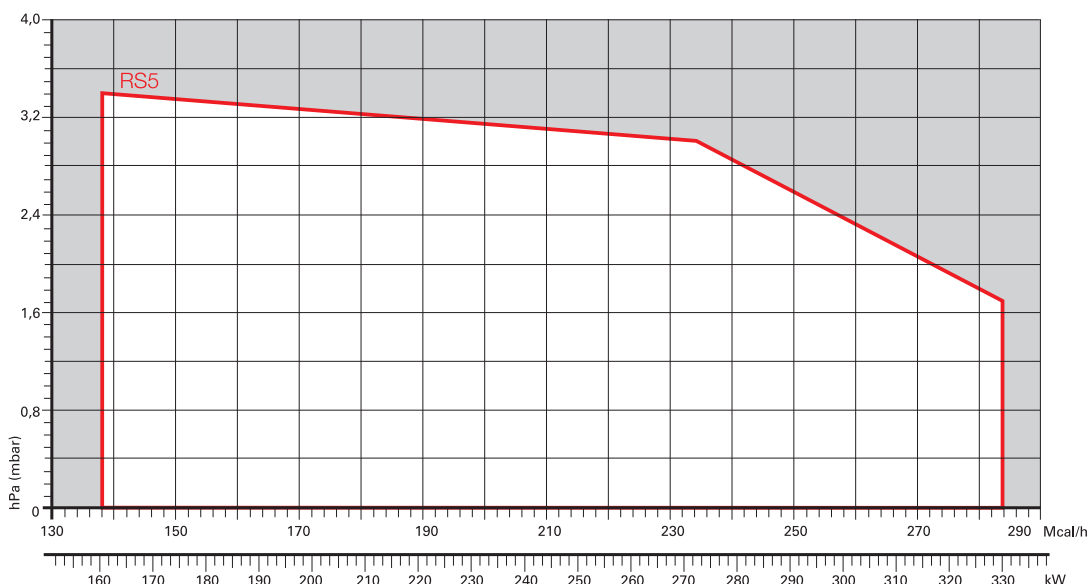

Useful working field for choosing the burner

Test conditions conforming to EN676
 Temperature: 20°C
 Pressure: 1013,5 mbar
 Altitude: 0 m a.s.l.

One Stage Gas Burners

GULLIVER RS SERIES

Overall dimensions (mm)

BURNER

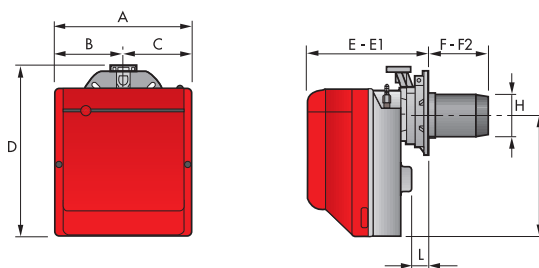

MODEL	A	B	C	D	E	E1	F	F2	H	I	L
▶ RS5	300	150	150	392	278	300	225	203	137	286	45
▶ RS5 TL	300	150	150	392	278	300	382	360	137	286	45

BURNER - BOILER MOUNTING FLANGE

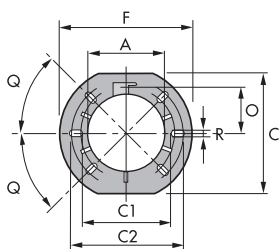

MODEL	A	C	C1	C2	F	O	Q	R
▶ RS5	137	203	170	200	218	80,5	45°	11
▶ RS5 TL	137	203	170	200	218	80,5	45°	11

PACKAGING

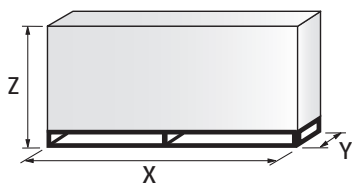

MODEL	X	Y	Z	kg
▶ RS5	600	345	430	18
▶ RS5 TL	703	335	435	20

Specification

DESIGNATION OF SERIES

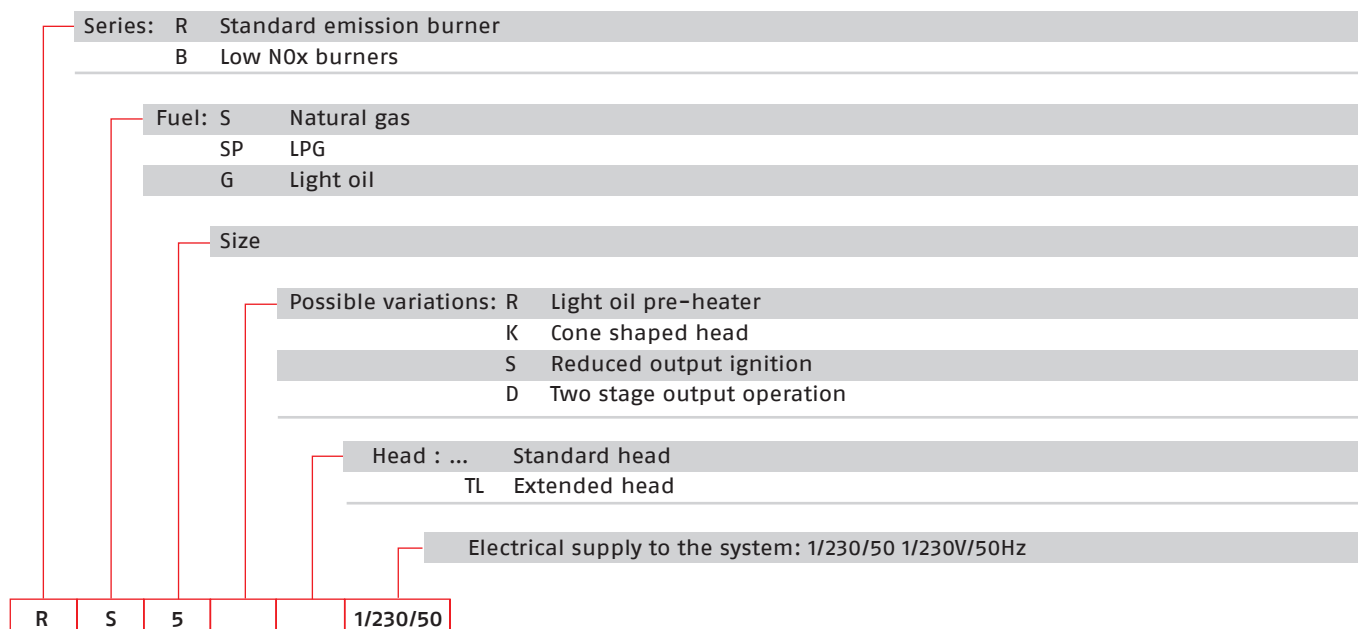

STATE OF SUPPLY

Monoblock, gas burner, completely automatic, one stage operation, made up of:

- Fan with forward curve blades
- Cover lined with sound-proofing material
- Air damper, completely closed in stand by, with external adjustment, with no need to remove the cover
- Single phase electric motor 230 V, 50 Hz
- Combustion head fitted with:
 - stainless steel head cone, resistant to high temperatures
 - ignition electrodes
 - ionisation probe
 - gas distributor
 - flame stability disk
- Flame inspection window
- Adjustable air pressure switch, with graduated selector, to guarantee burner lock out in the case of insufficient combustible air
- Microprocessor-based burner safety control box, with diagnostic and remote reset functions
- Protection filter against radio interference (included into burner safety control box)
- IP X0D (IP 40) electric protection level.

Standard equipment:

- Sliding flange
- Flange insulation screen
- Screws and nuts for fixing the flange to the boiler
- 7-pin plug
- Remote control release kit
- Instruction handbook for installation, use and maintenance
- Spare parts catalogue.

One Stage Gas Burners

GULLIVER RS SERIES

Available models

Burners

CODE	MODEL	HEAT OUTPUT		TOTAL ELECTRICAL POWER (kW)	CERTIFICATION	NOTE
		(kW)	NATURAL GAS (Nm ³ /h)			
3761958	RS5 1/230/50	160 - 330	16 - 33	0,430	CE - 0085 BM0114	(1)
20052614	RS5 TL 1/230/50	160 - 330	16 - 33	0,430	CE - 0085 BM0114	(1)

Net calorific value G20: 10 kWh/Nm³ - Density: 0,71 kg/Nm³.
The burners of RS series are in according to EN 676.
(1) With plug and socket.

Gas Trains

GAS TRAIN CODE *	GAS TRAIN MODEL	NATURAL GAS		LPG		NOTE
		BURNER (type)	ADAPTER (code)	BURNER (type)	ADAPTER (code)	
3970549	MB 410/1 - F3SD 20	RS5		RS5		(1) (2)
3970550	MB 412/1 - F3SD 20	RS5		RS5		(1) (3)
3970558	MB 415/1 - F3SD 30	RS5		RS5		(1)

Please see Designation of Gas Train Series in the page before the Catalogue index.

* Gas trains are 230V/50Hz - 220V/60Hz electrical supply.

(1) With installed plug.

(2) RS5 ≤ 200 kW with natural gas.

(3) RS5 ≤ 300 kW with natural gas.

The valve seal control device is compulsory (conforming to EN 676) on gas trains to burners with a maximum output over 1200 kW.
To select the gas train please refer to the technical data leaflet and/or instruction manual.

Burner accessories

Extended head kit

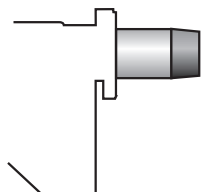

Burners standard head can be transformed into "extended head" versions by using the special kit.

BURNER	STANDARD HEAD LENGTH (mm)	EXTENDED HEAD LENGTH (mm)	KIT CODE
► RS5	203 ÷ 225	357 ÷ 372	3001016

LPG kit



For burning LPG gas, a special kit is available to be fitted to the combustion head on the burner, as shown in the following table.

BURNER	KIT CODE FOR STANDARD HEAD	KIT CODE (*)	KIT CODE FOR EXTENDED HEAD
► RS5	3001011	3002737	3001011

(*) Kit for LPG with butane amount over 30%, without CE certification

Burner accessories

Ground fault interrupter kit



A "Ground fault interrupter kit" is available as a safety device in case of electrical system fault. It is supplied with burners with pin plug.

BURNER	KIT CODE
► RS5	3001180

Multibloc rotation kit

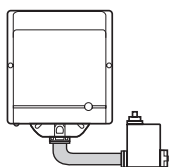

There is a special kit available that can be used to install the burner turned 180°. This kit is designed to ensure the gas train valve properly.

BURNER	KIT CODE
► RS5	3001178

7-pin plug kit

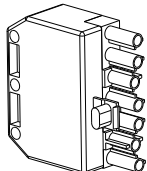

If necessary a 7-pin plug kit is available (in packaging of n. 5 pieces).

BURNER	KIT CODE
► RS5	3000945

Gas train accessories

Seal control kit



To test the valve seals on the gas train a special "seal control kit" is available.

GAS TRAIN	KIT CODE for 50 Hz operation	KIT CODE for 60 Hz operation
► MB/1 type	3010123	20168805

GULLIVER RSD SERIES

The Riello Gulliver RS5D is a new model of the series of two stage gas burners, characterized for its small dimensions in spite of its high combustion performance. It has been developed to respond to any request for home heating, conforming to current regulations in force. This model uses the same components designed by Riello for the Gulliver series. The high quality level guarantees safe working.

The burners are fitted with a microprocessor-based burner safety control box which supplies indication of operation and diagnosis of fault cause.

In developing this burner, special attention was paid to reducing noise, the ease of installation and adjustment, to obtaining the smallest size possible to fit into any sort of boiler available on the market.

This model is approved by the EN 676 European Standard and European Directives, Gas Appliance, EMC, Low Voltage, Boiler Efficiency.

The Gulliver RS5D burner is tested before leaving the factory.

Guidelines for installation of burners in conformity to EU Regulation:

A RIELLO burner (Heat Generator), where it is matched with a water-based boiler (Heater Housing) with a nominal output ≤ 400 kW, providing heat for heating purposes and heat to deliver sanitary hot water, can be installed:

- With boilers (heater housings) already in service in the field, for replacement of identical products, in conformity to Article 1, paragraph 2, point (G) of the EU Regulation No. 813/2013;
- With boilers (heater housings) on a new installation.



RS5D	160/208 ÷ 345	kW
RS5D TL	160/208 ÷ 345	kW

FIRING RATES

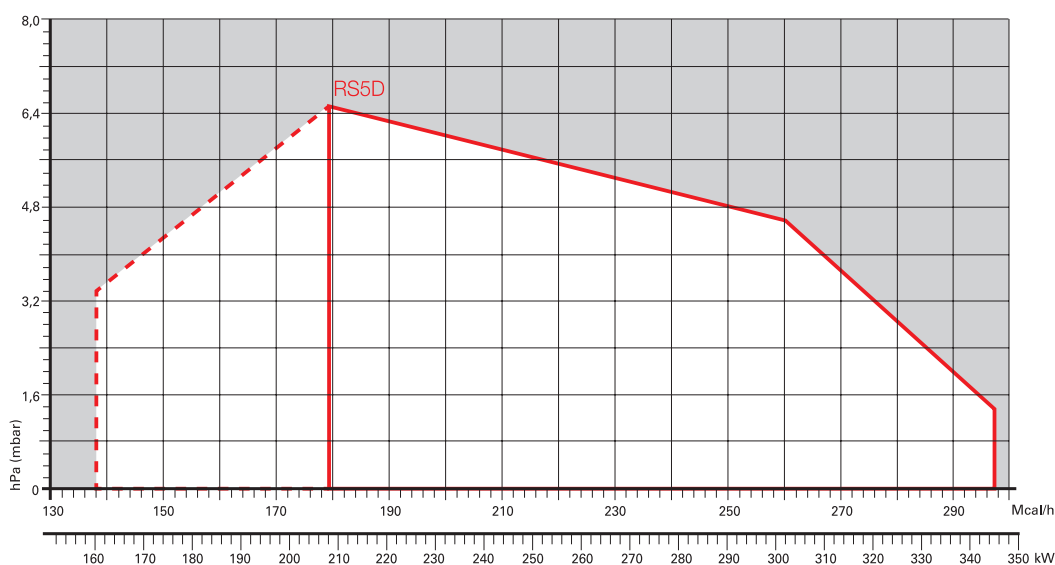

Useful working field for choosing the burner



1st stage operation range

Test conditions conforming to EN676
 Temperature: 20°C
 Pressure: 1013,5 mbar
 Altitude: 0 m a.s.l.

Two Stage Gas Burners

GULLIVER RSD SERIES

Overall dimensions (mm)

BURNER

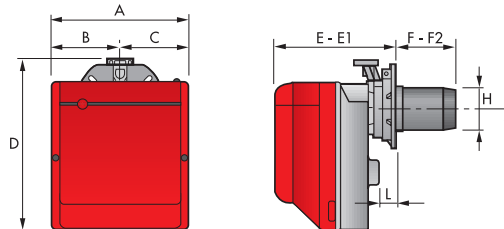

MODEL	A	B	C	D	E	E1	F	F2	H	I	L
▶ RS5D	300	150	150	392	278	300	203	225	137	286	45
▶ RS5D TL	300	150	150	392	278	300	382	360	137	286	45

BURNER - BOILER MOUNTING FLANGE

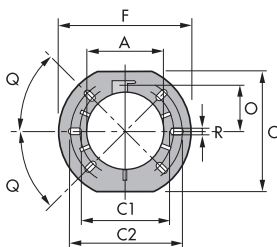

MODEL	A	C	C1	C2	F	O	Q	R
▶ RS5D	137	203	170	200	218	80,5	45°	11
▶ RS5D TL	137	203	170	200	218	80,5	45°	11

PACKAGING

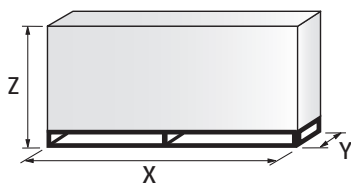

MODEL	X	Y	Z	kg
▶ RS5D	600	345	430	18
▶ RS5D TL	703	335	435	20

Specification

DESIGNATION OF SERIES

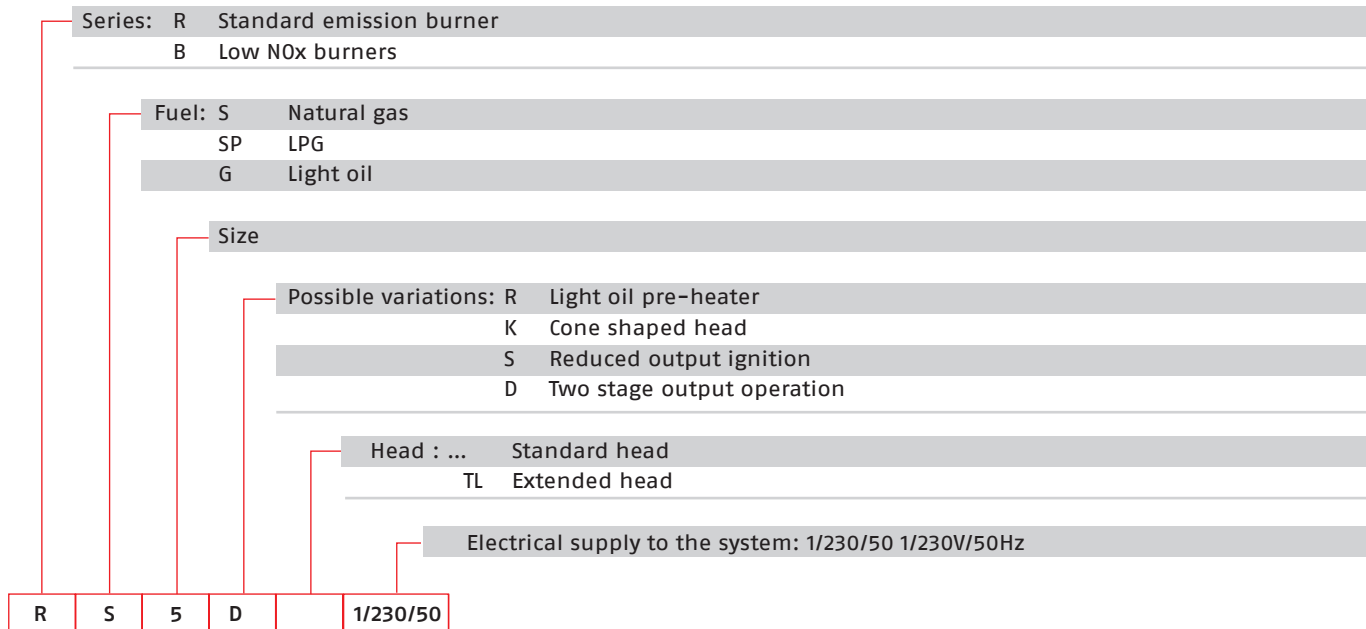

STATE OF SUPPLY

Monoblock, gas burner, completely automatic, with two stage settings fitted with:

- Fan with forward curve blades
- Cover lined with sound - proofing material
- Air damper, with 1st and 2nd stage adjustment, driven by an electric servomotor
- Single phase electric motor 230 V, 50 Hz
- Combustion head fitted with:
 - stainless steel head cone, resistant to high temperatures
 - ignition electrodes
 - ionisation probe
 - gas distributor
 - flame stability disk
- Flame inspection window
- Adjustable air pressure switch, with graduated selector, to guarantee burner lock out in the case of insufficient combustible air
- Microprocessor-based burner safety control box, with diagnostic and remote reset functions
- Protection filter against radio interference (included into burner safety control box)
- IP X0D (IP 40) electric protection level.

Standard equipment:

- Sliding flange
- Flange insulation screen
- Screws and nuts for fixing the flange to the boiler
- 7-pin plug
- 4-pin plug
- Remote control release kit
- Instruction handbook for installation, use and maintenance
- Spare parts catalogue.

Two Stage Gas Burners

GULLIVER RSD SERIES

Available models

Burners

CODE	MODEL	HEAT OUTPUT		TOTAL ELECTRICAL POWER (kW)	CERTIFICATION	NOTE
		(kW)	NATURAL GAS (Nm ³ /h)			
3762058	RS5D 1/230/50	160/208 - 345	16/20,8 - 34,5	0,450	CE - 0085 BN0325	(1)
20052615	RS5D TL 1/230/50	160/208 - 345	16/20,8 - 34,5	0,450	CE - 0085 BN0325	(1)

Net calorific value G20: 10 kWh/Nm³ - Density: 0,71 kg/Nm³.
The burners of RSD series are in according to EN 676.
(1) With plug and socket.

Gas Trains

GAS TRAIN CODE *	GAS TRAIN MODEL	NATURAL GAS		LPG		NOTE
		BURNER (type)	ADAPTER (code)	BURNER (type)	ADAPTER (code)	
3970542	MB 410/2 - F3SD 20	RS5D		RS5D		(1) (2)
3970543	MB 412/2 - F3SD 20	RS5D		RS5D		(1) (3)
3970582	MB 415/2 - F3SD 20	RS5D		RS5D		(1)

Please see Designation of Gas Train Series in the page before the Catalogue index.

* Gas trains are 230V/50Hz - 220V/60Hz electrical supply.

(1) With installed plug.

(2) RS5D ≤ 200 kW with natural gas.

(3) RS5D ≤ 300 kW with natural gas.

The valve seal control device is compulsory (conforming to EN 676) on gas trains to burners with a maximum output over 1200 kW.
To select the gas train please refer to the technical data leaflet and/or instruction manual.

Burner accessories

Extended head kit

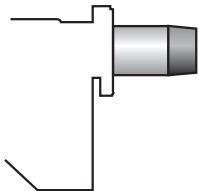

Burners standard head can be transformed into "extended head" versions by using the special kit.

BURNER	STANDARD HEAD LENGTH (mm)	EXTENDED HEAD LENGTH (mm)	KIT CODE
▶ RS5D	203 ÷ 225	357 ÷ 372	3001016

LPG kit



For burning LPG gas, a special kit is available to be fitted to the combustion head on the burner, as shown in the following table.

BURNER	KIT CODE FOR STANDARD HEAD	KIT CODE (*)	KIT CODE FOR EXTENDED HEAD
▶ RS5D	3001011	3002737	3001011

(*) Kit for LPG with butane amount over 30%, without CE certification

Burner accessories

Ground fault interrupter kit



A "Ground fault interrupter kit" is available as a safety device in case of electrical system fault. It is supplied with burners with pin plug.

BURNER	KIT CODE
► RS5D	3001180

Multibloc rotation kit

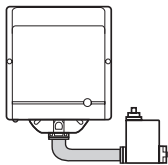

There is a special kit available that can be used to install the burner turned 180°. This kit is designed to ensure the gas train valve properly.

BURNER	KIT CODE
► RS5D	3001178

7-pin plug kit

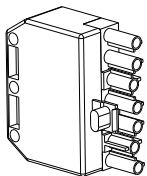

If necessary a 7-pin plug kit is available (in packaging of n. 5 pieces).

BURNER	KIT CODE
► RS5D	3000945

Gas train accessories

Seal control kit



To test the valve seals on the gas train a special "seal control kit" is available.

GAS TRAIN	KIT CODE for 50 Hz operation	KIT CODE for 60 Hz operation
► MB/1 type	3010123	20168805

RS/1 SERIES

The RS/1 series of burners covers a firing range from 70 to 550 kW, and they have been designed for use in low or medium temperature hot water boilers, hot air or steam boilers, diathermic oil boilers.

Operation is "one stage"; the burners are fitted with a microprocessor-based burner safety control box which supplies indication of operation and diagnosis of fault cause. Optimisation of sound emissions is guaranteed by the special design of the air suction circuit.

The elevated performance of the fans and combustion head, guarantee flexibility of use and excellent working at all firing rates.

The exclusive design ensures reduced dimensions, simple use and maintenance. Optimisation of sound emissions is guaranteed by the special design of the air suction circuit and by incorporated sound proofing material. A wide range of accessories guarantees elevated working flexibility.

Guidelines for installation of burners in conformity to EU Regulation:

A RIELLO burner (Heat Generator), where it is matched with a water-based boiler (Heater Housing) with a nominal output ≤ 400 kW, providing heat for heating purposes and heat to deliver sanitary hot water, can be installed:

- With boilers (heater housings) already in service in the field, for replacement of identical products, in conformity to Article 1, paragraph 2, point (G) of the EU Regulation No. 813/2013;
- With boilers (heater housings) on a new installation.



RS 34/1 MZ	70 ÷ 390 kW
RS 44/1 MZ	100 ÷ 550 kW

FIRING RATES

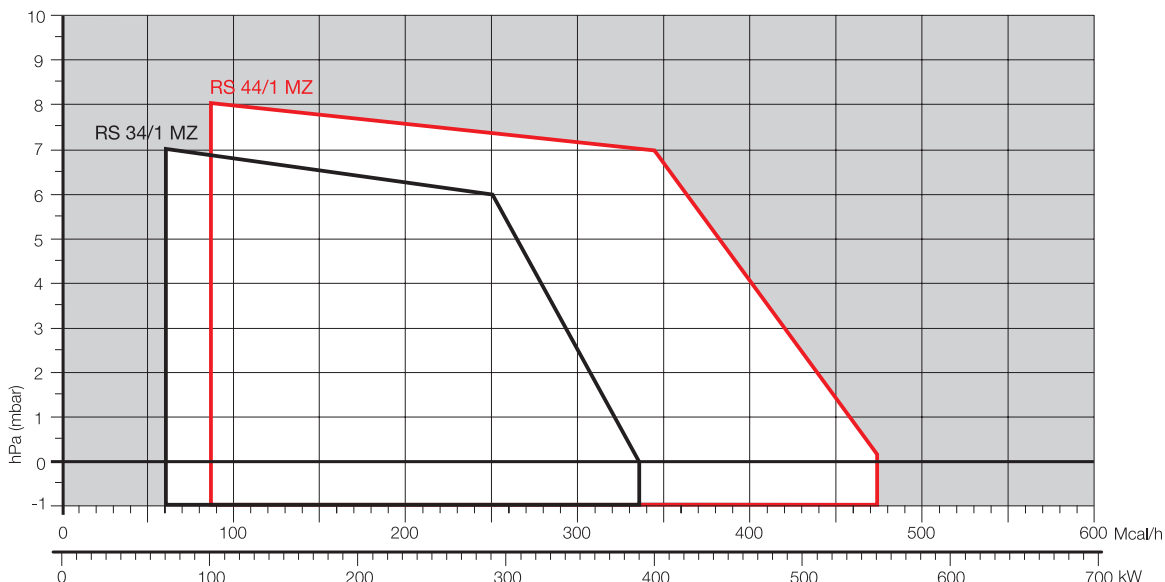

Useful working field for choosing the burner

Test conditions conforming to EN676
 Temperature: 20°C
 Pressure: 1013,5 mbar
 Altitude: 0 m a.s.l.

One Stage Gas Burners

RS/1 SERIES

Overall dimensions (mm)

BURNER

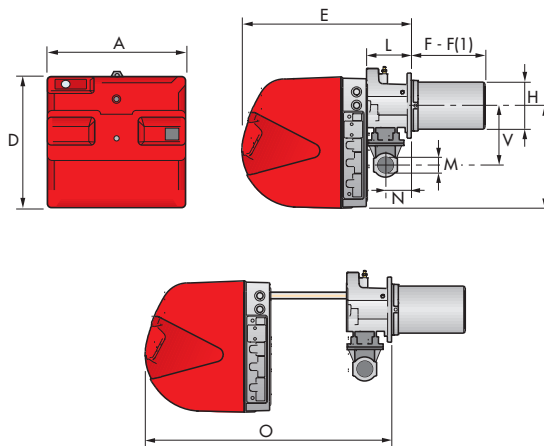

MODEL	A	D	E	F - F(1)	H	I	L	M	N	O	S	V
► RS 34/1 MZ	442	422	508	216 - 351	140	305	138	1 1/2	84	780	-	177
► RS 44/1 MZ	442	422	508	216 - 351	152	305	138	1 1/2	84	780	-	177

(1) dimension with extended head

BURNER - BOILER MOUNTING FLANGE

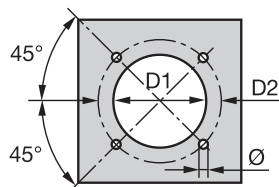

MODEL	D1	D2	Ø
► RS 34/1 MZ	160	224	M8
► RS 44/1 MZ	160	224	M8

PACKAGING

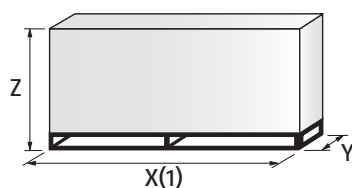

MODEL	X (1)	Y	Z	kg
► RS 34/1 MZ	1000	485	500	32
► RS 44/1 MZ	1000	485	500	33

(1) dimension with standard and extended head

Specification

DESIGNATION OF SERIES

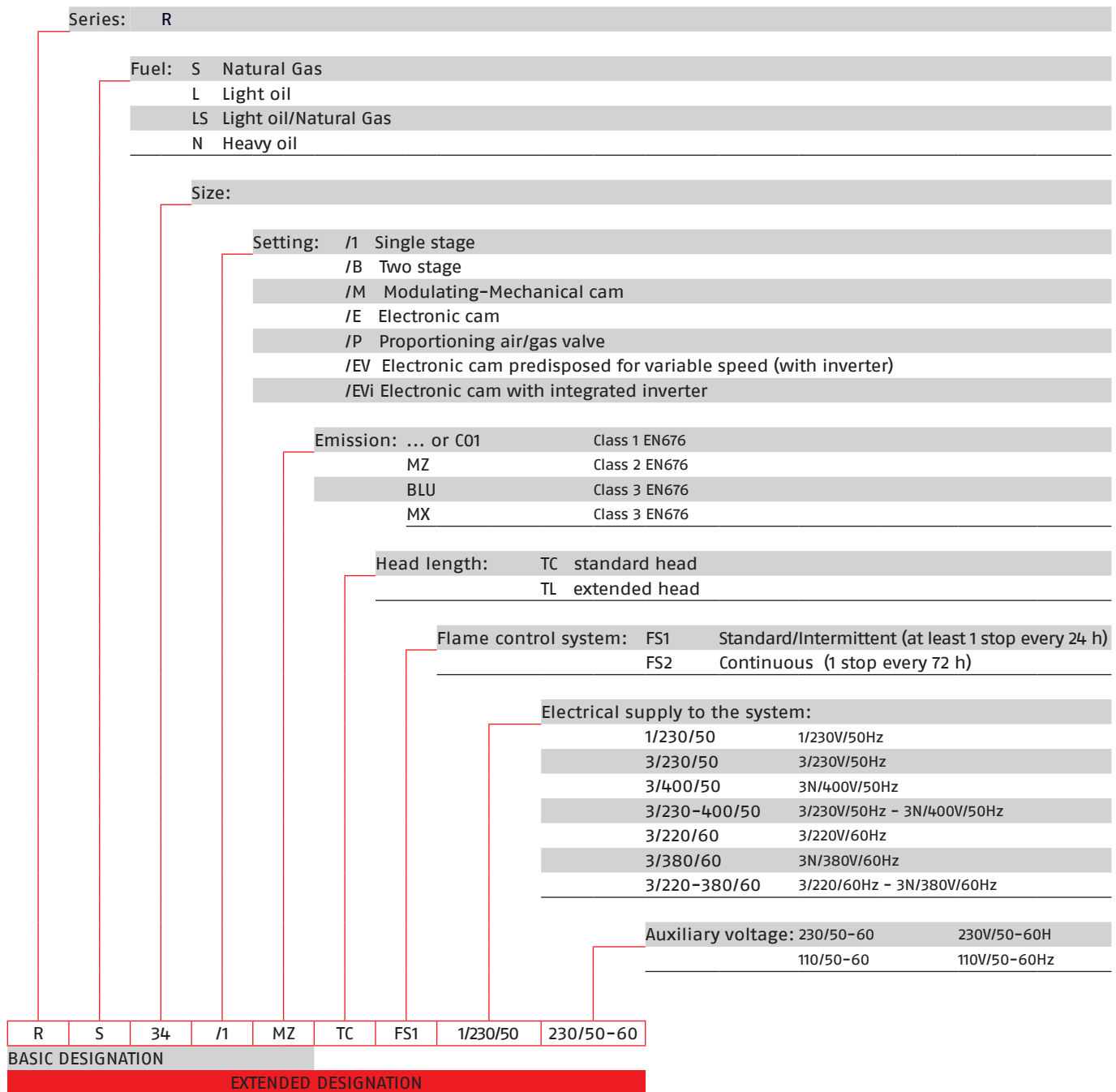

Specification

STATE OF SUPPLY

Monoblock forced draught gas burner with one stage operation, fully automatic, made up of:

- Air suction circuit with sound proofing material
- High performance fan with straight blades
- Air damper for air flow setting
- Starting motor at 2800 rpm, single-phase / 220-230V / 50-60Hz
- Combustion head, that can be set on the basis of required output, fitted with:
 - stainless steel end cone, resistant to corrosion and high temperatures
 - ignition electrodes
 - ionisation probe
 - gas distributor
 - flame stability disk
- Minimum air pressure switch stops the burner in case of insufficient air quantity at the combustion head
- Microprocessor-based burner safety control box, with diagnostic functions
- Plug and socket for electrical connections accessible from the external of the cover
- Flame inspection window
- Slide bars for easier installation and maintenance
- Protection filter against radio interference
- IP X0D (IP 40) electric protection level.

Standard equipment:

- 1 gas train flange
- 1 flange gasket
- 4 screws for fixing the flange
- 1 thermal screen
- 4 screws for fixing the burner flange to the boiler
- 3 plugs for electrical connection
- Instruction handbook for installation, use and maintenance
- Spare parts catalogue.

Available models

Burners

CODE	MODEL				HEAT OUTPUT NATURAL GAS		TOTAL ELECTRICAL POWER (kW)	CERTIFICATION	NOTE
					(kW)	(Nm ³ /h)			
3788510	RS 34/1 MZ	TC	FS1	1/230/50-60	230/50-60	70-390	7-39	0,6	CE0085BR0380
3788511	RS 34/1 MZ	TL	FS1	1/230/50-60	230/50-60	70-390	7-39	0,6	CE0085BR0380
3788610	RS 44/1 MZ	TC	FS1	1/230/50-60	230/50-60	100-550	10-55	0,7	CE0085BR0380
3788611	RS 44/1 MZ	TL	FS1	1/230/50-60	230/50-60	100-550	10-55	0,7	CE0085BR0380

Natural Gas, net calorific value: 10 kWh/Nm³ - Density at 20°C: 0,71 kg/Nm³

The burners of RS/1 series are in according to 2016/426/EU - 2014/30/EU - 2014/35/EU - 2006/42 CE Directive and EN 676 Norm.

Available models

Gas Trains

CODE	GAS TRAIN			VPS CODE	ADAPTER CODE	
	MODEL	Ø	C.T.		RS 34/1	RS 44/1
3970500*	MB 405/1 - RT 20	Rp 3/4"	-	3010123	3000824	
3970084*	MB 405/2 - RSD 20	Rp 1/2"	-	3010123	20044756	
3970553*	MB 407/1 - RT 20	Rp 3/4"	-	3010123	3000824	
3970599*	MB 407/1 - RT 52	Rp 3/4"	-	3010123		
3970229*	MB 407/1 - RSM 20	Rp 3/4"	-	3010123		
3970537*	MB 407/2 - RSD 20	Rp 3/4"	-	3010123		
3970556*	MB 407/2 - RT 20	Rp 3/4"	-	3010123		
3970258*	MB 410/1 - RT 52	Rp 1" 1/4	-	3010123	3010124	3010124
3970554*	MB 410/1 - RT 20	Rp 3/4"	-	3010123	3000824	
3970600*	MB 410/1 - RT 52	Rp 3/4"	-	3010123		
3970230*	MB 410/1 - RSM 20	Rp 3/4"	-	3010123		
3970534*	MB 410/2 - RSD 20	Rp 3/4"	-	3010123		
3970557*	MB 410/2 - RT 20	Rp 3/4"	-	3010123		
3970256*	MB 412/1 - RT 52	Rp 1" 1/2	-	3010123	<input type="checkbox"/>	<input type="checkbox"/>
3970144*	MB 412/1 - RT 20	Rp 1" 1/2	-	3010123	<input type="checkbox"/>	<input type="checkbox"/>
3970197**	MB 412/1 CT RT 20	Rp 1" 1/2	◆	-	<input type="checkbox"/>	<input type="checkbox"/>
3970231*	MB 412/1 - RSM 20	Rp 1" 1/2	-	3010123	<input type="checkbox"/>	<input type="checkbox"/>
3970152*	MB 412/2 - RT 20	Rp 1" 1/2	-	3010123	<input type="checkbox"/>	<input type="checkbox"/>
3970180*	MB 415/1 - RT 30	Rp 1" 1/2	-	3010123	<input type="checkbox"/>	<input type="checkbox"/>
3970198**	MB 415/1 CT RT 30	Rp 1" 1/2	◆	-	<input type="checkbox"/>	<input type="checkbox"/>
3970250*	MB 415/1 - RT 52	Rp 1" 1/2	-	3010123	<input type="checkbox"/>	<input type="checkbox"/>
3970253**	MB 415/1 CT RT 52	Rp 1" 1/2	◆	-	<input type="checkbox"/>	<input type="checkbox"/>
3970232*	MB 415/1 - RSM 30	Rp 1" 1/2	-	3010123	<input type="checkbox"/>	<input type="checkbox"/>
3970183*	MB 415/2 - RT 20	Rp 1" 1/2	-	3010123	<input type="checkbox"/>	<input type="checkbox"/>
3970181*	MB 420/1 - RT 30	Rp 2"	-	3010123	3000822	
3970182**	MB 420/1 CT RT 30	Rp 2"	◆	-		
3970257*	MB 420/1 - RT 52	Rp 2"	-	3010123		
3970252**	MB 420/1 CT RT 52	Rp 2"	◆	-		
3970233*	MB 420/1 - RSM 30	Rp 2"	-	3010123		
3970234**	MB 420/1 CT RSM 30	Rp 2"	◆	-		
3970184*	MB 420/2 - RT 20	Rp 2"	-	3010123		
3970185**	MB 420/2 CT RT 20	Rp 2"	◆	-		
3970221*	MBC 1200/1 - RSM 60	Rp 2"	-	3010123		
3970225**	MBC 1200/1 CT RSM 60	Rp 2"	◆	-		
3970222*	MBC 1900/1 - FSM 40	DN 65	-	3010123	●	●
3970226**	MBC 1900/1 CT FSM 40	DN 65	◆	-	●	●
3970223*	MBC 3100/1 - FSM 40	DN 80	-	3010123	●	●
3970227**	MBC 3100/1 CT FSM 40	DN 80	◆	-	●	●

Please see designation of Gas Train Series in the page before the Catalogue index.

* 230V/50Hz -220V/60Hz electrical supply.

** 230V/50Hz electrical supply.

The valve seal control device is compulsory (conforming to EN 676) on gas trains to burners with a maximum output over 1200 kW.

The seal control function is managed by LMV control box, by installation on gas train of pressure switch supplied, as standard equipment, with the burner.

To select the gas train please refer to the technical data leaflet and/or instruction manual.

C.T. Gas valve leak detection control device:

- gas train not equipped with leak detection control device; this device can be ordered separately - see VPS column - and installed later.

◆ gas train equipped with leak detection control device.

VPS Valve leak detection control device. Supplied separately from the gas train (please see Gas train accessories paragraph for both 50 Hz and 60 Hz codes).

● Not available.

□ Additional adapter not necessary, the gas train may be connected directly to the burner.

One Stage Gas Burners

RS/1 SERIES

Available models

Gas Trains

CODE	GAS TRAIN			VPS CODE	ADAPTER CODE		
	MODEL	Ø	C.T.		RS 34/1	RS 44/1	
3970145*	CB 512/1 - RSM 30	Rp 1" ½	-	3010123	<input type="checkbox"/>	<input type="checkbox"/>	
20045589**	CB 512/1 CT RSM 30	Rp 1" ½	◆	-	<input type="checkbox"/>	<input type="checkbox"/>	
3970153*	CB 512/2 - RT 32	Rp 1" ½	-	3010123	<input type="checkbox"/>	<input type="checkbox"/>	
3970146*	CB 520/1 - RSM 30	Rp 2"	-	3010123	3000822		
3970160**	CB 520/1 CT RSM 30	Rp 2"	◆	-			
3970154*	CB 520/2 - RT 32	Rp 2"	-	3010123			
20044659*	CB 525/1 - RSM 30	Rp 2"	-	3010123			
20044660**	CB 525/1 CT RSM 30	Rp 2"	◆	-			
3970147*	CB 5065/1 - FSM 30	DN 65	-	3010123			●
3970161**	CB 5065/1 CT FSM 30	DN 65	◆	-	●		
3970155*	CB 5065/2 - FT 32	DN 65	-	3010123	●		
3970167**	CB 5065/2 CT FT 32	DN 65	◆	-	●		
3970148*	CB 5080/1 - FSM 30	DN 80	-	3010123	●	●	
3970162**	CB 5080/1 CT FSM 30	DN 80	◆	-	●	●	
3970149*	CB 50100/1 - FSM 30	DN 100	-	3010123	●	●	
3970163**	CB 50100/1 CT FSM 30	DN 100	◆	-	●	●	

Please see designation of Gas Train Series in the page before the Catalogue index.

* gas train are 230V/50Hz - 220V/60Hz electrical supply.

The valve seal control device is compulsory (conforming to EN 676) on gas trains to burners with a maximum output over 1200 kW.

To select the gas train please refer to the technical data leaflet and/or instruction manual.

C.T. Gas valve leak detection control device:

- gas train not equipped with leak detection control device; this device can be ordered separately - see VPS column - and installed later.
- ◆ gas train equipped with leak detection control device.

VPS Valve leak detection control device. Supplied separately from the gas train (please see Gas train accessories paragraph for both 50 Hz and 60 Hz codes).

● Not available.

□ Additional adapter not necessary, the gas train may be connected directly to the burner.

Burner accessories

Extended head kit

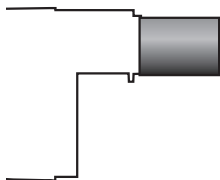

"Standard head" burners can be transformed into "extended head" versions, by using the special kit. The KITS available for the various burners, giving the original and the extended lengths, are listed below.

BURNER	'STANDARD HEAD' LENGTH (mm)	'EXTENDED HEAD' LENGTH (mm)	KIT CODE
▶ RS 34/1 MZ	216	351	3010428
▶ RS 44/1 MZ	216	351	3010429

Spacer kit

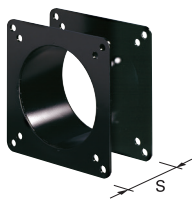

If burner head penetration into the combustion chamber needs reducing, varying thickness spacers are available, as given in the following table:

BURNER	SPACER THICKNESS S (mm)	KIT CODE
▶ RS 34/1 MZ - 44/1 MZ	110	3010095

Post-ventilation kit

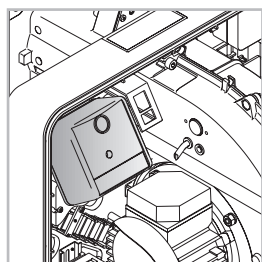

To prolong ventilation for approximately 20 seconds after opening of thermostats chain, a special kit is available.

BURNER	KIT CODE
▶ RS 34/1 MZ - 44/1 MZ	3010452

Continuous ventilation kit



If the burner requires continuous ventilation in the stages without flame, a special kit is available as given in the following table:

BURNER	KIT CODE
▶ RS 34/1 MZ - 44/1 MZ	3010449

One Stage Gas Burners

RS/1 SERIES

Burner accessories

Sound proofing box

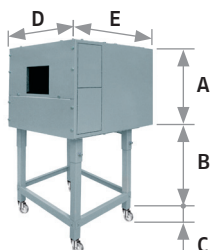

If noise emission needs reducing even further, sound-proofing boxes are available. When a lower "B" dimension is required, it is available the Box Support Kit code 20065135 which allows to reduce it at the fixed dimension of 55 mm. The sound-proofing boxes are not suitable for outdoor use.

BURNER	BOX TYPE	A (mm)	B (mm) min-max	C (mm)	D (mm)	E (mm)	[dB(A)] (*)	BOX CODE
▶ RS 34/1 MZ RS 44/1 MZ	C1/3	650	372 - 980	110	690	770	10	3010403

(*) Average noise reduction according to EN 15036-1 standard

LPG kit



For burning LPG gas, a special kit is available to be fitted to the combustion head on the burner, as given in the following table:

BURNER	KIT CODE
▶ RS 34/1 MZ	3010423
▶ RS 44/1 MZ	3010424

Town gas kit

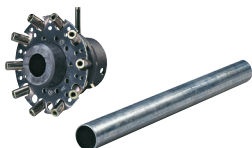

For burning Town gas, a special kit is available:

BURNER	KIT CODE FOR 'STANDARD HEAD' (*)	KIT CODE FOR 'EXTENDED HEAD' (*)
▶ RS 34/1 MZ	3010502	3010502
▶ RS 44/1 MZ	3010503	3010503

(*) Without CE certification

Hours counter kit

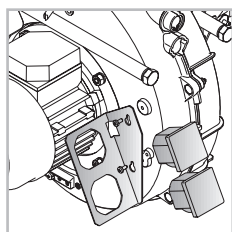

To measure the burner working time a hours counter kit is available.

BURNER	KIT CODE
▶ RS 34/1 MZ - 44/1 MZ	3010450

Ground fault interrupter kit



A "Ground fault interrupter kit" is available as a safety device for electrical system fault.

BURNER	KIT CODE
▶ RS 34/1 MZ - 44/1 MZ	3010448

Burner accessories

Vibration reduction kit



The kit allow you to improve flame stability in some applications, where the boiler/flue assembly is liable to resonate.

BURNER	KIT CODE	NOTE
▶ RS 34/1 MZ (Natural Gas)	20098750	(1)
▶ RS 34/1 MZ (LPG)	20098753	(2)
▶ RS 44/1 MZ (Natural Gas)	20098746	(1)

(1) CE approved

(2) CE approval on field is required

Gas max pressure switch

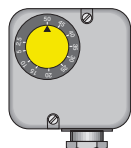

If necessary a Gas max pressure Switch kit is available and connectable to the burner electrical wiring through Plugs & Sockets system.

BURNER	KIT CODE
▶ RS 34/1 MZ - 44/1 MZ	3010418

Volt free contact kit



A volt free contact kit is available for installation onto the burner. It can be used for a remote interface between burner operating signals. Every burner can be equipped with a single kit for a remote check of the flame presence signal and the burner lock-out indication.

BURNER	KIT CODE
▶ RS 34/1 MZ - 44/1 MZ	3010419

PC interface kit



To connect the RMG control box to a personal computer for the transmission of operation, fault signals and detailed service information, an interface adapter with PC software are available.

BURNER	KIT CODE
▶ RS 34/1 MZ - 44/1 MZ	3002719

Protection kit (electromagnetic interferences)

When the burner is installed in a room particularly subject to electromagnetic interference (signals emitted over 10 V/m) due for example to INVERTER presence or in systems where the lengths of the thermostat connections is over 20 meters, this specific protection kit is available as an interface between the thermostatic controls and the burner.

BURNER	KIT CODE
▶ All models	3010386





One Stage Gas Burners

RS/1 SERIES

Gas train accessories

Adapters

In certain cases, an adapter must be fitted between the gas train and the burner, when the diameter of the gas train is different from the set diameter of the burner. Below are given the available adapters; please see on the Gas Train list the correct adapter codes to select.

ADAPTER	LENGTH mm	ADAPTER CODE
2"  1" 1/2	70	3000822
3/4"  1" 1/2	31	3000824
1/2"  1" 1/2	31	20044756
1" 1/4"  1" 1/2	35	3010124
1" 1/4"  2"	35	3010126

Seal control kit



To test the valve seals on the gas train, a special "seal control kit" is available. The valve seal control device is compulsory (EN 676) on gas trains to burners with a maximum output over 1200 kW. The sealing control is type VPS 504.

GAS TRAIN	KIT CODE for 50 Hz operation	KIT CODE for 60 Hz operation
MB 405/1 – MB 407/1 – MB 407/2 – MB 410/1 – MB 410/2 ▶ MB 412/1 – MB 412/2 – MB 415/1 – CB 512/1 MB 415/2 – CB 512/2 – MB 420/2 – CB 520/2	3010123	20168805

Stabiliser spring



To vary the pressure range of the gas train stabilisers, accessory springs are available. The following table shows these accessories with their application range. Please refer to the technical manual for the correct choice of spring.

GAS TRAIN	SPRING COLOUR	SPRING PRESSURE RANGE mbar	SPRING CODE
▶ CB 512/1 – 512/2	Red	25 – 55	3010131
	Black	60 – 110	3010157
	Pink	90 – 150	3090486
▶ CB 520/1 – 520/2 – 525/1	Red	25 – 55	3010132
	Black	60 – 110	3010158
	Pink	100 – 150	3090487

RS SERIES

The RS burners series covers a firing range from 44 to 2290 kW, and it has been designed for use in low or medium temperature hot water boilers, hot air or steam boilers, diathermic oil boilers.

Operation is "two stage progressive"; the burners are fitted with a microprocessor-based burner safety control box which supplies indication of operation and diagnosis of fault cause.

The elevated performance of the fans and combustion head, guarantee flexibility of use and excellent working at all firing rates.

The exclusive design ensures reduced dimensions, simple use and maintenance. Optimisation of sound emissions is guaranteed by the special design of the air suction circuit and by incorporated sound proofing material. A wide range of accessories guarantees elevated working flexibility.

Guidelines for installation of burners in conformity to EU Regulation:

A RIELLO burner (Heat Generator), where it is matched with a water-based boiler (Heater Housing) with a nominal output ≤ 400 kW, providing heat for heating purposes and heat to deliver sanitary hot water, can be installed:

- With boilers (heater housings) already in service in the field, for replacement of identical products, in conformity to Article 1, paragraph 2, point (G) of the EU Regulation No. 813/2013;
- With boilers (heater housings) on a new installation.

RS 34 MZ	45/125 ÷	390 kW
RS 44 MZ	80/203 ÷	550 kW
RS 50	115/290 ÷	600 kW
RS 64 MZ	150/400 ÷	850 kW
RS 70	192/465 ÷	814 kW
RS 100	232/698 ÷	1163 kW
RS 130	372/930 ÷	1512 kW
RS 150	300/900 ÷	1850 kW
RS 190	470/1279 ÷	2290 kW

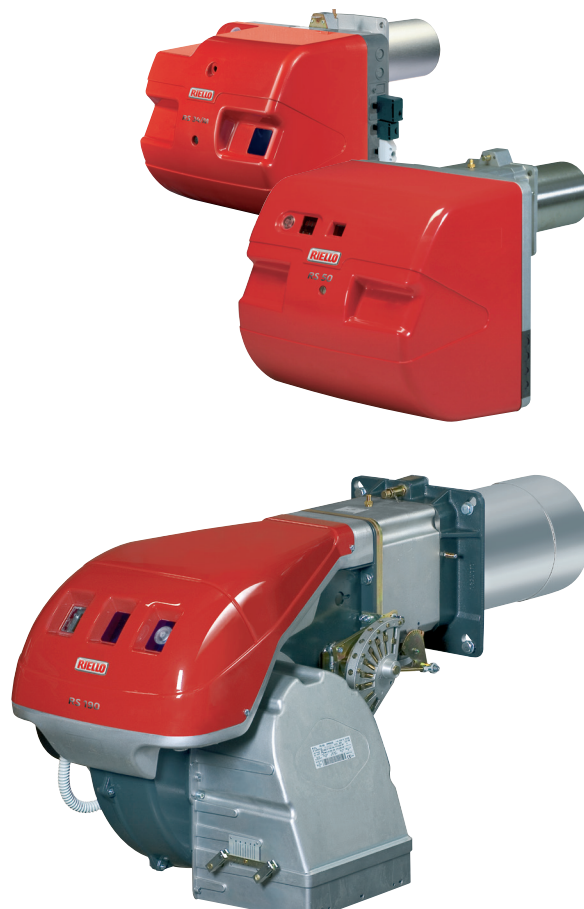

FIRING RATES

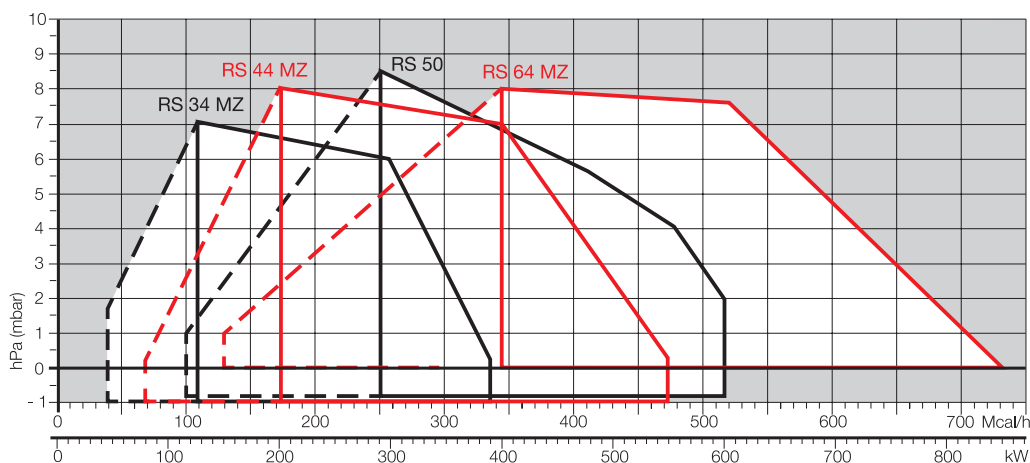

 Useful working field for choosing the burner

 1st stage operation range

Test conditions conforming to EN676
 Temperature: 20°C
 Pressure: 1013,5 mbar
 Altitude: 0 m a.s.l.

Two Stage Progressive Gas Burners

RS SERIES

FIRING RATES

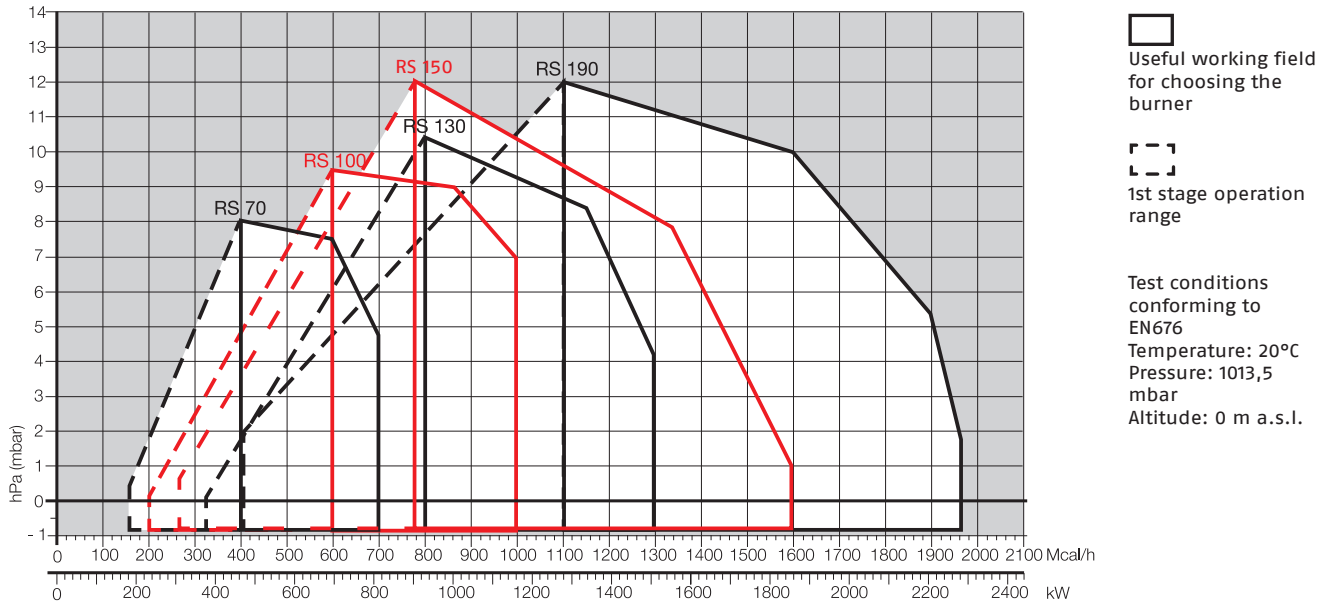

Overall dimensions (mm)

BURNER

RS 34 MZ - 44 MZ

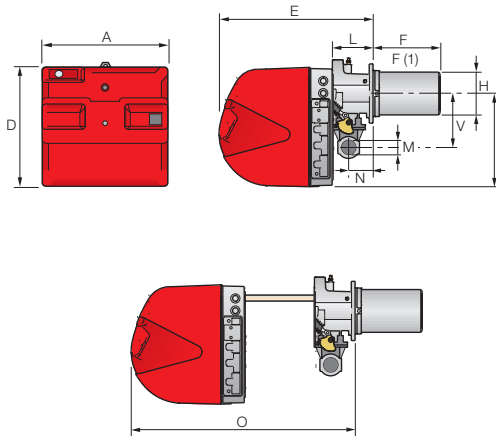

RS 50

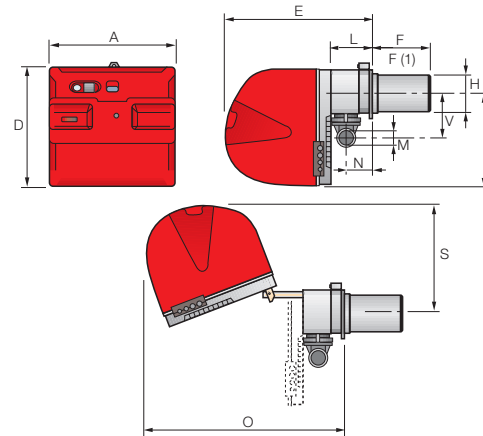

MODEL	A	D	E	F - F(1)	H	I	L	M	N	O	S	V
▶ RS 34 MZ	442	422	508	216 - 351	140	305	138	1 1/2	84	780	-	177
▶ RS 44 MZ	442	422	508	216 - 351	152	305	138	1 1/2	84	780	-	177
▶ RS 50	476	474	580	216 - 351	152	352	164	1 1/2	108	810	367	168

(1) dimension with extended head

RS 64 MZ

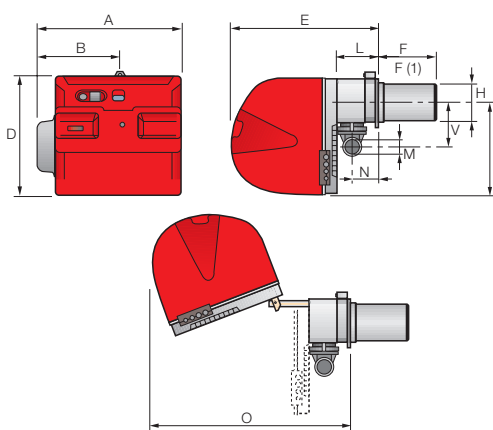

RS 70 - 100 - 130 - 150 - 190

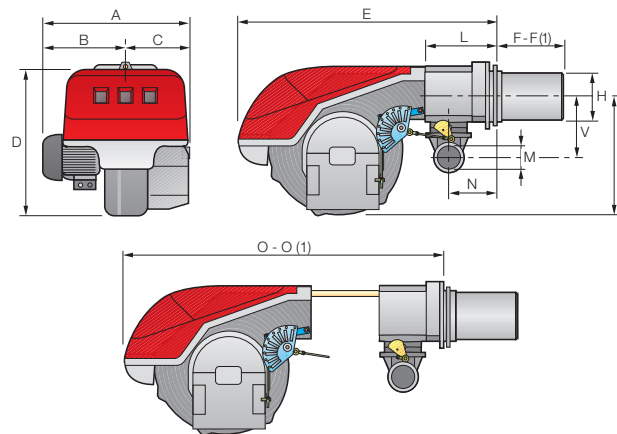

MODEL	A	B	C	D	E	F - F(1)	H	I	L	M	N	O - O(1)	V
▶ RS 64 MZ	533	300	-	490	640	250 - 385	179	352	222	2"	134	870 - -	221
▶ RS 70	511	296	215	555	840	250 - 385	179	430	214	2"	134	1161 - 1296	221
▶ RS 100	527	312	215	555	840	250 - 385	179	430	214	2"	134	1161 - 1296	221
▶ RS 130	553	338	215	555	840	280 - 415	189	430	214	2"	134	1161 - 1296	221
▶ RS 150	675	370	305	590	840	280 - 415	189	435	214	2"	134	1180 - 1315	221
▶ RS 190	681	366	315	555	872	370 - 520	222	430	246	2"	150	1328 - -	262

(1) dimension with extended head

Two Stage Progressive Gas Burners

RS SERIES

Overall dimensions (mm)

BURNER - BOILER MOUNTING FLANGE

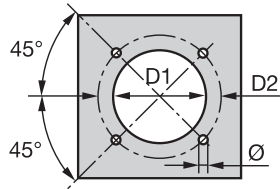

MODEL	D1	D2	Ø
▶ RS 34 MZ	160	224	M8
▶ RS 44 MZ	160	224	M8
▶ RS 50	160	224	M8
▶ RS 64 MZ	185	275-325	M12
▶ RS 70	185	275-325	M12
▶ RS 100	185	275-325	M12
▶ RS 130	195	275-325	M12
▶ RS 150	195	275-325	M12
▶ RS 190	230	325-368	M16

PACKAGING

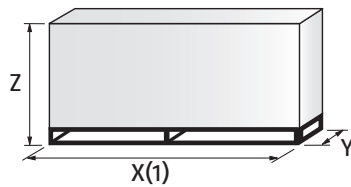

MODEL	X (1)	Y	Z	kg
▶ RS 34 MZ	1000	485	500	32
▶ RS 44 MZ	1000	485	500	33
▶ RS 50	1200	502	520	41
▶ RS 64 MZ	1200	580	520	42
▶ RS 70	1405	700	660	70
▶ RS 100	1405	700	660	73
▶ RS 130	1400	700	660	76
▶ RS 150	1400-1420	1000	660	110
▶ RS 190	1400-1420	1000	660	115

(1) dimension with standard and extended head

Specification

DESIGNATION OF SERIES

Series: R									
Fuel: S Natural Gas									
L Light oil									
LS Light oil/Natural Gas									
N Heavy oil									
Size:									
Setting: /1 Single stage									
/B Two stage									
/M Modulating-Mechanical cam									
/E Electronic cam									
/P Proportioning air/gas valve									
/EV Electronic cam predisposed for variable speed (with inverter)									
/EVi Electronic cam with integrated inverter									
Emission: ... or CO1					Class 1 EN676				
MZ					Class 2 EN676				
BLU					Class 3 EN676				
MX					Class 3 EN676				
Head length: TC standard head									
TL extended head									
Flame control system: FS1 Standard/Intermittent (at least 1 stop every 24 h)									
FS2 Continuous (1 stop every 72 h)									
Electrical supply to the system:									
1/230/50					1/230V/50Hz				
3/230/50					3/230V/50Hz				
3/400/50					3N/400V/50Hz				
3/230-400/50					3/230V/50Hz - 3N/400V/50Hz				
3/220/60					3/220V/60Hz				
3/380/60					3N/380V/60Hz				
3/220-380/60					3/220/60Hz - 3N/380V/60Hz				
Auxiliary voltage: 230/50-60 230V/50-60H									
110/50-60 110V/50-60Hz									

R	S	130			TC	FS1	3/230-400/50	230/50-60
---	---	-----	--	--	----	-----	--------------	-----------

BASIC DESIGNATION

EXTENDED DESIGNATION

Two Stage Progressive Gas Burners

RS SERIES

Specification

STATE OF SUPPLY

RS 34 MZ – 44 MZ models

Monoblock forced draught gas burner with two stage operation, fully automatic, made up of:

- Air suction circuit with sound proofing material
- High performance fan with straight blades
- Air damper for air flow setting and butterfly valve for regulating fuel output on 1st and 2nd stage controlled by a servomotor with variable cam
- Starting motor at 2800 rpm, single-phase / 220-230V / 50-60Hz or three-phase / 380-400V / 50-60Hz
- Combustion head, that can be set on the basis of required output, fitted with:
 - stainless steel end cone, resistant to corrosion and high temperatures
 - ignition electrodes
 - ionisation probe
 - gas distributor
 - flame stability disk
- Exclusive patented HCS (Housing Cooling System) with high thermal insulation and air circulation with continuous air volume refresh for an active cooling system and avoid heat transfer to the electrical component housing
- Minimum air pressure switch stops the burner in case of insufficient air quantity at the combustion head
- Microprocessor-based burner safety control box, with diagnostic functions
- Plug and socket for electrical connections accessible from the external of the cover
- Burner on/off selection switch
- 1st – 2nd stage manual switch
- Flame inspection window
- Slide bars for easier installation and maintenance
- Protection filter against radio interference
- IP X0D (IP 40) electric protection level.

Standard equipment

- 1 gas train flange
- 1 flange gasket
- 4 screws for fixing the flange
- 1 thermal screen
- 4 screws for fixing the burner flange to the boiler
- 3 plugs for electrical connection (RS 34 – 44 MZ single-phase)
- 4 plugs for electrical connection (RS 44 MZ three-phase)
- Instruction handbook for installation, use and maintenance
- Spare parts catalogue.

RS SERIES

Specification

STATE OF SUPPLY

RS 50 - 64 MZ - 70 - 100 - 130 - 150 - 190 models

Monoblock forced draught gas burner with two stage operation, fully automatic, made up of:

- Air suction circuit lined with sound-proofing material
- Fan with reverse curve blades (RS 50 - 70 - 100 - 130 models) or straight blades (RS 64 MZ - 150-190 models)
- Air damper for air flow setting and butterfly valve for regulating fuel output on 1st and 2nd stage controlled by a servomotor with variable cam
- Starting motor at 2800 rpm, three-phase 400V with neutral, 50Hz
- Combustion head, that can be set on the basis of required output, fitted with:
 - stainless steel end cone, resistant to corrosion and high temperatures
 - ignition electrodes
 - ionisation probe
 - gas distributor
 - flame stability disk
- Minimum air pressure switch stops the burner in case of insufficient air quantity at the combustion head
- Microprocessor-based burner safety control box, with diagnostic functions
- Plug and socket for electrical connections (RS 50-64 models)
- Burner on/off selection switch
- 1st - 2nd stage manual switch
- Flame inspection window
- Slide bars for easier installation and maintenance
- Protection filter against radio interference
- IP 44 electric protection level.

Standard equipment

- 1 gas train flange
- 1 flange gasket
- 4 screws for fixing the flange
- 1 thermal screen
- 4 screws for fixing the burner flange to the boiler
- Wiring loom fittings for the electrical connection (RS 50-64)
- 2 slide bar extensions (for extended head models and RS 150-190 model)
- Instruction handbook for installation, use and maintenance
- Spare parts catalogue.

Two Stage Progressive Gas Burners

RS SERIES

Available models

Burners

CODE	MODEL					HEAT OUTPUT NATURAL GAS		TOTAL ELECTRICAL POWER (kW)	CERTIFICATION	NOTE
						(kW)	(Nm ³ /h)			
3789010	RS 34 MZ	TC	FS1	1/230/50-60	230/50-60	44/130-390	4,5/13-39	0,6	CE 0085BR0381	(1)
3789011	RS 34 MZ	TL	FS1	1/230/50-60	230/50-60	44/130-390	4,5/13-39	0,6	CE 0085BR0381	(1)
20008266	RSP 34	TC	FS1	1/230/50-60	230/50-60	44/130-390	4,5/13-39	0,6	CE 0085BR0381	(1)
3789110	RS 44 MZ	TC	FS1	1/230/50-60	230/50-60	80/200-550	8/20-55	0,7	CE 0085BR0381	(1)
3789111	RS 44 MZ	TL	FS1	1/230/50-60	230/50-60	80/200-550	8/20-55	0,7	CE 0085BR0381	(1)
3789140	RS 44 MZ	TC	FS1	3/230-400/50-60	230/50-60	80/200-550	8/20-55	0,8	CE 0085BR0381	(1)
3789141	RS 44 MZ	TL	FS1	3/230-400/50-60	230/50-60	80/200-550	8/20-55	0,8	CE 0085BR0381	(1)
3784702	RS 50	TC	FS1	3/230-400/50	230/50-60	115/290-600	12/29-58	0,75	CE 0085AP0735	(1)
3784703	RS 50	TL	FS1	3/230-400/50	230/50-60	115/290-600	12/29-58	0,75	CE 0085AP0735	(1)
3784720	RS 50	TC	FS1	3/220-380/60	230/50-60	115/290-600	12/29-58	0,75	-	(1)
3784721	RS 50	TL	FS1	3/220-380/60	230/50-60	115/290-600	12/29-58	0,75	-	(1)
3789310	RS 64 MZ	TC	FS1	3/230-400/50	230/50-60	150/400-850	15/40-85	1,5	CE 0085BR0558	(1)
3789311	RS 64 MZ	TL	FS1	3/230-400/50	230/50-60	150/400-850	15/40-85	1,5	CE 0085BR0558	(1)
3789380	RS 64 MZ	TC	FS1	3/220-380/60	230/50-60	150/400-850	15/40-85	1,5	-	(1)
3785102	RS 70	TC	FS1	3/230-400/50	230/50-60	192/465-814	19/46,5-81	1,4	CE 0085AP0944	(2)
3785103	RS 70	TL	FS1	3/230-400/50	230/50-60	192/465-814	19/46,5-81	1,4	CE 0085AP0944	(2)
3785104	RS 70	TC	FS1	3/230-400/50	230/50-60	192/465-814	19/46,5-81	1,4	CE 0085AP0944	(1) (2)
3785105	RS 70	TL	FS1	3/230-400/50	230/50-60	192/465-814	19/46,5-81	1,4	CE 0085AP0944	(1) (2)
3785120	RS 70	TC	FS1	3/220-380/60	230/50-60	192/465-814	19/46,5-81	1,4	-	(2)
3785121	RS 70	TL	FS1	3/220-380/60	230/50-60	192/465-814	19/46,5-81	1,4	-	(2)
3785302	RS 100	TC	FS1	3/230-400/50	230/50-60	232/698-1163	23/70-116	1,8	CE 0085AP0945	(2)
3785303	RS 100	TL	FS1	3/230-400/50	230/50-60	232/698-1163	23/70-116	1,8	CE 0085AP0945	(2)
3785304	RS 100	TC	FS1	3/230-400/50	230/50-60	232/698-1163	23/70-116	1,8	CE 0085AP0945	(1) (2)
3785305	RS 100	TL	FS1	3/230-400/50	230/50-60	232/698-1163	23/70-116	1,8	CE 0085AP0945	(1) (2)
3785320	RS 100	TC	FS1	3/220/380-460/60	230/50-60	232/698-1163	23/70-116	1,8	-	(2)
3785321	RS 100	TL	FS1	3/220/380-460/60	230/50-60	232/698-1163	23/70-116	1,8	-	(2)
3785502	RS 130	TC	FS1	3/230-400/50	230/50-60	372/930-1512	37/93-151	2,6	CE 0085AP0946	(2)
3785503	RS 130	TL	FS1	3/230-400/50	230/50-60	372/930-1512	37/93-151	2,6	CE 0085AP0946	(2)
3785504	RS 130	TC	FS1	3/230-400/50	230/50-60	372/930-1512	37/93-151	2,6	CE 0085AP0946	(1) (2)
3785505	RS 130	TL	FS1	3/230-400/50	230/50-60	372/930-1512	37/93-151	2,6	CE 0085AP0946	(1) (2)
3785520	RS 130	TC	FS1	3/220/380-460/60	230/50-60	372/930-1512	37/93-151	2,6	-	(2)
3785521	RS 130	TL	FS1	3/220/380-460/60	230/50-60	372/930-1512	37/93-151	2,6	-	(2)
20044636	RS 150	TC	FS1	3/400/50	230/50-60	300/900÷1850	30/90÷185	3,5	CE 0085CS0428	(2)
20044637	RS 150	TL	FS1	3/400/50	230/50-60	300/900÷1850	30/90÷185	3,5	CE 0085CS0428	(2)
3785813	RS 190	TC	FS1	3/400/50	230/50-60	470/1279-2290	47/128-229	5,5	CE 0085AT0042	(2)
20030087	RS 190	TL	FS1	3/400/50	230/50-60	470/1279-2290	47/128-229	5,5	CE 0085AT0042	(2)
3785814	RS 190	TC	FS1	3/400/50	230/50-60	470/1279-2290	47/128-229	5,5	CE 0085AT0042	(1) (2)
3785820	RS 190	TC	FS1	3/380/60	230/50-60	470/1279-2290	47/128-229	5,5	-	(2)
20011699	RS 190	TC	FS1	3/220/60	220/60	470/1279-2290	47/128-229	5,5	-	(2)

Natural Gas, net calorific value: 10 kWh/Nm³ - Density at 20°C: 0,71 kg/Nm³

The burners of RS series are in according to 2016/426/EU - 2014/30/EU - 2014/35/EU - 2006/42 CE Directive and EN 676 Norm.

(1) With plug and socket. (2) With terminal board.

RS SERIES

Available models

Gas Trains

CODE	GAS TRAIN			VPS CODE	ADAPTER CODE							
	MODEL	Ø	C.T.		RS 34	RS 44-50	RS 64	RS 70	RS 100	RS 130	RS 150	RS 190
3970500*	MB 405/1 - RT 20	Rp ¾"	-	3010123	3000824	●	●	●	●	●	●	
3970553*	MB 407/1 - RT 20	Rp ¾"	-	3010123		●	●	●	●	●	●	
3970599*	MB 407/1 - RT 52	Rp ¾"	-	3010123		●	●	●	●	●	●	
3970229*	MB 407/1 - RSM 20	Rp ¾"	-	3010123		●	●	●	●	●	●	
3970258*	MB 410/1 - RT 52	Rp 1" ¼"	-	3010123	3010124	3000843	●	●	●	●	●	
3970554*	MB 410/1 - RT 20	Rp ¾"	-	3010123	3000824	3000824 + 3000843	●	●	●	●	●	
3970600*	MB 410/1 - RT 52	Rp ¾"	-	3010123			●	●	●	●	●	●
3970230*	MB 410/1 - RSM 20	Rp ¾"	-	3010123			●	●	●	●	●	●
3970256*	MB 412/1 - RT 52	Rp 1" ½"	-	3010123	□	□	3000843	3000843	3000843	3000843	3000843	
3970144*	MB 412/1 - RT 20	Rp 1" ½"	-	3010123	□	□						
3970197**	MB 412/1 CT RT 20	Rp 1" ½"	◆	-	□	□						
3970231*	MB 412/1 - RSM 20	Rp 1" ½"	-	3010123	□	□						
3970180*	MB 415/1 - RT 30	Rp 1" ½"	-	3010123	□	□						
3970198**	MB 415/1 CT RT 30	Rp 1" ½"	◆	-	□	□						
3970250*	MB 415/1 - RT 52	Rp 1" ½"	-	3010123	□	□						
3970253**	MB 415/1 CT RT 52	Rp 1" ½"	◆	-	□	□						
3970232*	MB 415/1 - RSM 30	Rp 1" ½"	-	3010123	□	□						
3970181*	MB 420/1 - RT 30	Rp 2"	-	3010123	□	□						
3970182**	MB 420/1 CT RT 30	Rp 2"	◆	-	□	□						
3970257*	MB 420/1 - RT 52	Rp 2"	-	3010123	□	□						
3970252**	MB 420/1 CT RT 52	Rp 2"	◆	-	□	□						
3970233*	MB 420/1 - RSM 30	Rp 2"	-	3010123	□	□						
3970234**	MB 420/1 CT RSM 30	Rp 2"	◆	-	□	□						
3970221*	MBC 1200/1 - RSM 60	Rp 2"	-	3010123	□	□						
3970225**	MBC 1200/1 CT RSM 60	Rp 2"	◆	-	□	□						
3970222*	MBC 1900/1 - FSM 40	DN 65	-	3010123	●	●	3000825	3000825	3000825	3000825	3000825	
3970226**	MBC 1900/1 CT FSM 40	DN 65	◆	-	●	●						

Please see designation of Gas Train Series in the page before the Catalogue index.

* 230V/50Hz -220V/60Hz electrical supply.

** 230V/50Hz electrical supply.

The valve seal control device is compulsory (conforming to EN 676) on gas trains to burners with a maximum output over 1200 kW.

To select the gas train please refer to the technical data leaflet and/or instruction manual.

C.T. Gas valve leak detection control device:

- gas train not equipped with leak detection control device; this device can be ordered separately - see VPS column - and installed later.

◆ gas train equipped with leak detection control device.

VPS Valve leak detection control device. Supplied separately from the gas train (please see Gas train accessories paragraph for both 50 Hz and 60 Hz codes).

● Not available.

□ Additional adapter not necessary, the gas train may be connected directly to the burner.

Two Stage Progressive Gas Burners

RS SERIES

Available models

Gas Trains

CODE	GAS TRAIN			VPS CODE	ADAPTER CODE								
	MODEL	Ø	C.T.		RS 34	RS 44-50	RS 64	RS 70	RS 100	RS 130	RS 150	RS 190	
3970223*	MBC 3100/1 - FSM 40	DN 80	-	3010123	●	●							
3970227**	MBC 3100/1 CT FSM 40	DN 80	◆	-	●	●							3000826
3970145*	CB 512/1 - RSM 30	Rp 1" 1/2	-	3010123	□	□							
20045589**	CB 512/1 CT RSM 30	Rp 1" 1/2	◆	-	□	□							3000843
3970146*	CB 520/1 - RSM 30	Rp 2"	-	3010123			□	□	□	□	□	□	
3970160**	CB 520/1 CT RSM 30	Rp 2"	◆	-			□	□	□	□	□	□	
20044659*	CB 525/1 - RSM 30	Rp 2"	-	3010123			□	□	□	□	□	□	
20044660**	CB 525/1 CT RSM 30	Rp 2"	◆	-			□	□	□	□	□	□	
3970147*	CB 5065/1 - FSM 30	DN 65	-	3010123	●								
3970161**	CB 5065/1 CT FSM 30	DN 65	◆	-	●								3000825
3970148*	CB 5080/1 - FSM 30	DN 80	-	3010123	●	●							
3970162**	CB 5080/1 CT FSM 30	DN 80	◆	-	●	●							3000826
3970149*	CB 50100/1 - FSM 30	DN 100	-	3010123	●	●							
3970163**	CB 50100/1 CT FSM 30	DN 100	◆	-	●	●							3010370 + 3000826
20015871*	CB 50125/1 - FSM 30	DN 125	-	3010123	●	●	●	●	●				
3970196**	CB 50125/1 CT FSM 30	DN 125	◆	-	●	●	●	●	●				3010224 + 3000826

Please see designation of Gas Train Series in the page before the Catalogue index.

* 230V/50Hz -220V/60Hz electrical supply.

** 230V/50Hz electrical supply.

The valve seal control device is compulsory (conforming to EN 676) on gas trains to burners with a maximum output over 1200 kW.

To select the gas train please refer to the technical data leaflet and/or instruction manual.

C.T. Gas valve leak detection control device:

- gas train not equipped with leak detection control device; this device can be ordered separately - see VPS column - and installed later.

◆ gas train equipped with leak detection control device.

VPS Valve leak detection control device. Supplied separately from the gas train (please see Gas train accessories paragraph for both 50 Hz and 60 Hz codes).

● Not available.

□ Additional adapter not necessary, the gas train may be connected directly to the burner.

Burner accessories

Extended head kit

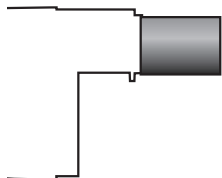

“Standard head” burners can be transformed into “extended head” versions, by using the special kit. The KITS available for the various burners, giving the original and the extended lengths, are listed below.

BURNER	'STANDARD HEAD' LENGTH (mm)	'EXTENDED HEAD' LENGTH (mm)	KIT CODE
▶ RS 34 MZ	216	351	3010428
▶ RS 44 MZ	216	351	3010429
▶ RS 50	216	351	3010078
▶ RS 64 MZ	250	385	3010427
▶ RS 70	250	385	3010117
▶ RS 100	250	385	3010118
▶ RS 130	280	415	3010119
▶ RS 150	280	415	20052186
▶ RS 190	370	520	3010443 *

* Kit to be used on burners recognizable by a serial number that is over or equal to 02426XXXXXX, for burners with a serial number that is under or equal to 02416XXXXX please use the Kit coded 3010196

Spacer kit

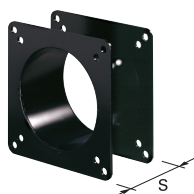

If burner head penetration into the combustion chamber needs reducing, varying thickness spacers are available, as given in the following table:

BURNER	SPACER THICKNESS S (mm)	KIT CODE
▶ RS 34 MZ - 44 MZ - 50	110	3010095
▶ RS 64 MZ - 70 - 100 - 130 - 150	135	3010129
▶ RS 190	102	3000722

Continuous ventilation kit



If the burner requires continuous ventilation in the stages without flame, a special kit is available as given in the following table:

BURNER	KIT CODE
▶ RS 34 MZ - 44 MZ	3010449
▶ RS 50 - 64 - 70 - 100 - 130 - 150 - 190	3010094

Post-ventilation kit



To prolong ventilation after opening of thermostats chain, a special kit is available.

BURNER	POST-VENTILATION TIME (s)	KIT CODE
▶ All models	5	3010004
	20	3010452

Two Stage Progressive Gas Burners

RS SERIES

Burner accessories

Connection flange kit

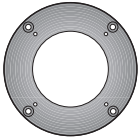

A kit is available for use where the burner opening on the boiler is of excessive diameter.

BURNER	KIT CODE
► RS 34 MZ - 44 MZ - 50	3010138

Sound proofing box

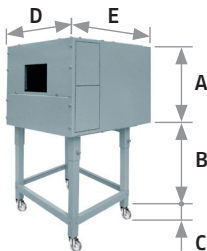

If noise emission needs reducing even further, sound-proofing boxes are available. When a lower "B" dimension is required, it is available the Box Support Kit code 20065135 which allows to reduce it at the fixed dimension of 55 mm. The sound-proofing boxes are not suitable for outdoor use.

BURNER	BOX TYPE	A (mm)	B (mm) min-max	C (mm)	D (mm)	E (mm)	[dB(A)] (*)	BOX CODE
► RS 34 MZ - 44 MZ RS 50 - RS 64 MZ	C1/3	650	372 - 980	110	690	770	10	3010403
► RS 70 - 100 - 130 - 150 - 190	C4/5	850	160 - 980	110	980	930	10	3010404

(*) Average noise reduction according to EN 15036-1 standard

LPG kit

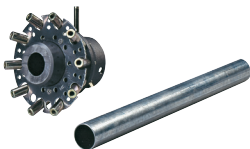

For burning LPG gas, a special kit is available to be fitted to the combustion head on the burner, as given in the following table:

BURNER	KIT CODE FOR 'STANDARD HEAD'	KIT CODE FOR 'EXTENDED HEAD'
► RS 34 MZ	3010423	3010423
► RS 44 MZ	3010424	3010424
► RS 50	20008173	20008173
► RS 64 MZ	3010434	3010435
► RS 70	20008175	20008176
► RS 100	20008177	20008178
► RS 130	20008179	20008180
► RS 150	20050064	20050065
► RS 190	3010166	3010166

Clean contacts kit

BURNER	KIT CODE
► RS 70-100-130	20123294

Burner accessories

Town gas kit



For burning Town gas, a special kit is available:

BURNER	KIT CODE FOR 'STANDARD HEAD' (*)	KIT CODE FOR 'EXTENDED HEAD' (*)
▶ RS 34 MZ	3010502	3010502
▶ RS 44 MZ	3010503	3010503
▶ RS 50	3010285	3010285
▶ RS 70	3010286	3010286
▶ RS 100	3010287	3010287
▶ RS 130	3010288	3010288
▶ RS 190	3010297	3010297

(*) Without CE certification

Vibration reduction kit



The kit allow you to improve flame stability in some applications, where the boiler/flue assembly is liable to resonate.

BURNER	KIT CODE	NOTE
▶ RS 34 MZ (Natural Gas)	20098750	(1)
▶ RS 34 MZ (LPG)	20098753	(2)
▶ RS 44 MZ (Natural Gas)	20098746	(1)
▶ RS 50 TC - RS 50 TL	3010200	(1)
▶ RS 70 TC - RS 70 TL	3010201	(1)
▶ RS 100 TC - RS 100 TL	3010202	(1)
▶ RS 130 TC	3010373	(1)
▶ RS 130 TL	3010374	(1)
▶ RS 190 TC	3010375	(1)

(1) CE approved

(2) CE approval on field is required

Ground fault interrupter kit



A "Ground fault interrupter kit" is available as a safety device for electrical system fault.

BURNER	KIT CODE
▶ RS 34 MZ - 44 MZ	3010448
▶ RS 50 - RS 64 MZ	3010321
▶ RS 70 - 100 - 130 - 150 - 190	3010329

Gas max pressure switch kit

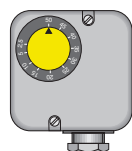

If necessary a Gas max pressure Switch kit is available.

BURNER	KIT CODE
▶ RS 34 MZ - 44 MZ*	3010418
▶ RS 50 - 64 MZ - 70 - 100 - 130 - 150 - 190	3010493

* Connectable to the burner electrical wiring through Plugs & Sockets system

Two Stage Progressive Gas Burners

RS SERIES

Burner accessories

Volt free contact kit

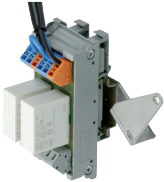

A volt free contact kit is available for installation onto the burner. It can be used for a remote interface between burner operating signals. Every burner can be equipped with a single kit for a remote check of the flame presence signal and the burner lockout indication.

BURNER	KIT CODE
► RS 34 MZ - 44 MZ - 64 MZ	3010419

PC interface kit



To connect the RMG control box to a personal computer for the transmission of operation, fault signals and detailed service information, an interface adapter with PC software are available.

BURNER	KIT CODE
► RS 34 MZ - 44 MZ - 50 - 64 MZ - 70 - 100 - 130 - 150 - 190	3002719

Hours counter kit

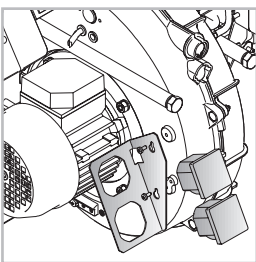

To measure the burner working time a hours counter kit is available.

BURNER	KIT CODE
► RS 34 MZ - 44 MZ	3010450

DN80 gas flange kit

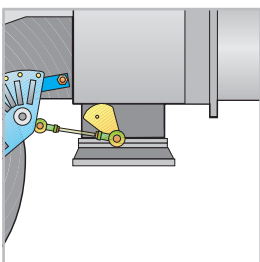

To modify the standard 2" burner gas input connection in to DN80 connection, a specific gas flange is available.

BURNER	KIT CODE
► RS 64 MZ - 70 - 100 - 130 - 150 - 190	3010439

Burner accessories

Protection kit (electromagnetic interferences)

When the burner is installed in a room particularly subject to electromagnetic interference (signals emitted over 10 V/m) due for example to INVERTER presence or in systems where the lengths of the thermostat connections is over 20 meters, this specific protection kit is available as an interface between the thermostatic controls and the burner.

BURNER	KIT CODE
► All models	3010386

Head kit for “reverse flame chamber”



In certain cases, the use of the burner on reverse flame boilers can be improved by using an additional cylinder.

BURNER	STANDARD HEAD LENGTH WITH CYLINDER (mm)	EXTENDED HEAD LENGTH WITH CYLINDER (mm)	KIT CODE (*)
► RS 190	493	-	3010241

(*) CE approval on field is required

Gas train accessories

Adapters

In certain cases, an adapter must be fitted between the gas train and the burner, when the diameter of the gas train is different from the set diameter of the burner. Below are given the available adapters; please see on the Gas Train list the correct adapter codes to select.

ADAPTER	LENGTH mm	ADAPTER CODE
2" 1" 1/2	70	3000822
3/4" 1" 1/2	31	3000824
DN 65 2" 1/2 1" 1/2	300	3000825
DN 80 2" 1/2 2"	300	3000826
1" 1/2 2"	35	3000843
1" 1/4 1" 1/2	35	3010124
1" 1/4 2"	35	3010126

Two Stage Progressive Gas Burners

RS SERIES

Gas train accessories

Stabiliser spring



Accessory springs are available to vary the pressure range of the gas train stabilisers. The following table shows these accessories with their application range. Please refer to the technical manual for the correct choice of spring.

GAS TRAIN	SPRING COLOUR	SPRING PRESSURE RANGE mbar	SPRING CODE
▶ MBC 1900/1 – 3100/1 MBC 5000/1	White	4 – 20	3010381
	Red	20 – 40	3010382
	Black	40 – 80	3010383
	Green	80 – 150	3010384
▶ CB 512/1	Red	25 – 55	3010131
	Black	60 – 110	3010157
	Pink	90 – 150	3090486
▶ CB 520/1 – 525/1	Red	25 – 55	3010132
	Black	60 – 110	3010158
	Pink	100 – 150	3090487
▶ CB 5065/1 – 5080/1	Red	25 – 55	3010133
	Black	60 – 110	3010135
	Pink	100 – 150	3090456
	Grey	140 – 200	3090992

Seal control kit



To test the valve seals on the gas train, a special “seal control kit” is available. The valve seal control device is compulsory (EN 676) on gas trains to burners with a maximum output over 1200 kW. The seal control is type VPS 504.

GAS TRAIN	KIT CODE for 50 Hz operation	KIT CODE for 60 Hz operation
▶ MB/1 type	3010123	20168805
▶ MBC/1 type	3010123	20168805
▶ CB/1 type	3010123	20168805

RS/M SERIES

The RS/M burners series covers a firing range from 45 to 2650 kW, and it has been designed for use in low or medium temperature hot water boilers, hot air or steam boilers, diathermic oil boilers.

Operation can be "two stage progressive" or, alternatively, "modulating" with the installation of a PID logic regulator and respective probes.

RS/M burners series guarantees high efficiency levels in all the various applications, thus reducing fuel consumption and running costs.

The exclusive design ensures reduced dimensions, simple use and maintenance. Optimisation of sound emissions is guaranteed by the special design of the air suction circuit and by incorporated sound proofing material.

A wide range of accessories guarantees elevated working flexibility.

Guidelines for installation of burners in conformity to EU Regulation:

A RIELLO burner (Heat Generator), where it is matched with a water-based boiler (Heater Housing) with a nominal output ≤ 400 kW, providing heat for heating purposes and heat to deliver sanitary hot water, can be installed:

- With boilers (heater housings) already in service in the field, for replacement of identical products, in conformity to Article 1, paragraph 2, point (G) of the EU Regulation No. 813/2013;
- With boilers (heater housings) on a new installation.



RS 34/M MZ	45/125 ÷	390 kW
RS 44/M MZ	80/203 ÷	550 kW
RS 50/M MZ	80/285 ÷	630 kW
RS 64/M MZ	150/400 ÷	850 kW
RS 70/M	150/470 ÷	930 kW
RS 100/M	150/700 ÷	1340 kW
RS 130/M	254/920 ÷	1600 kW
RS 150/M	300/900 ÷	1850 kW
RS 190/M	470/1279 ÷	2290 kW
RS 250/M MZ	600/1250 ÷	2650 kW

FIRING RATES

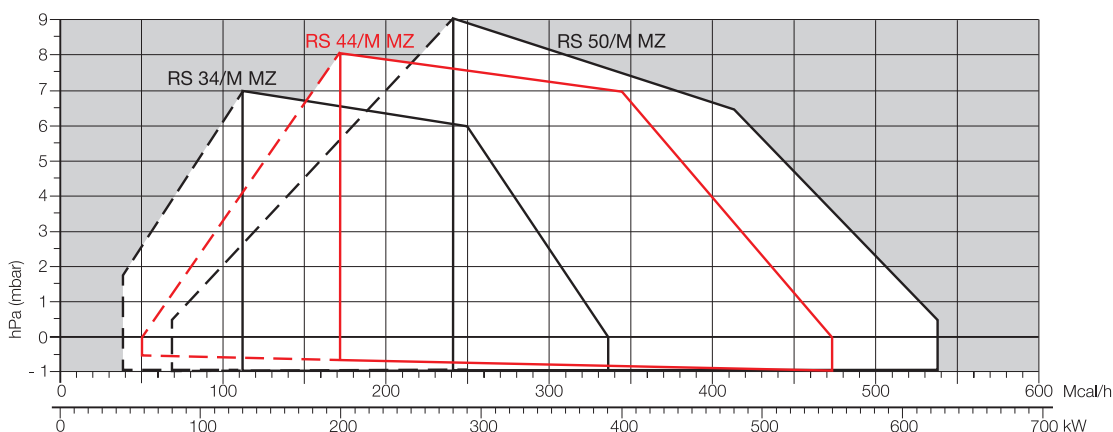

Useful working field for choosing the burner

Modulation range

Test conditions conforming to EN676
 Temperature: 20°C
 Pressure: 1013,5 mbar
 Altitude: 0 m a.s.l.

Modulating Gas Burners

RS/M SERIES

FIRING RATES

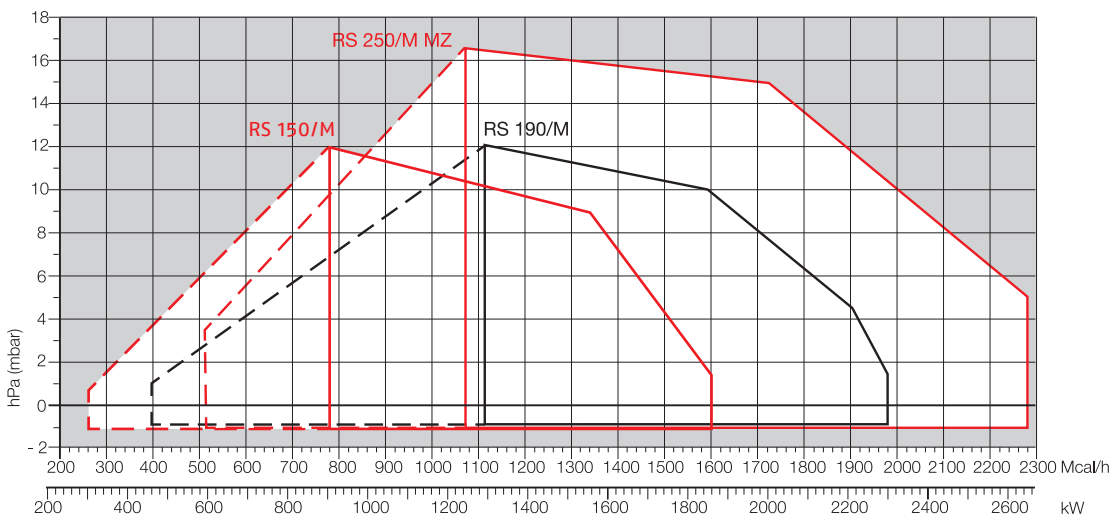
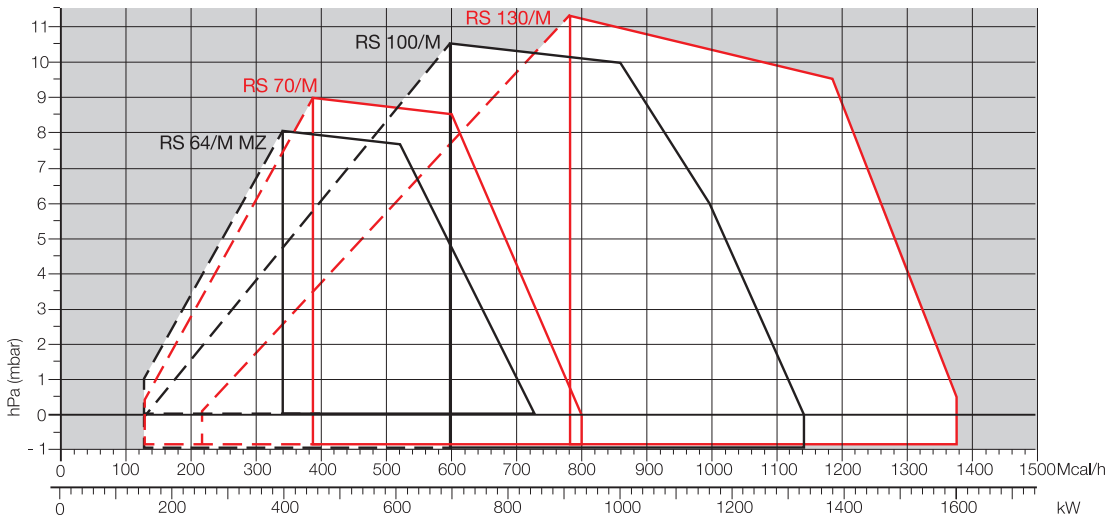

Overall dimensions (mm)

BURNER

RS 34/M MZ - 44/M MZ

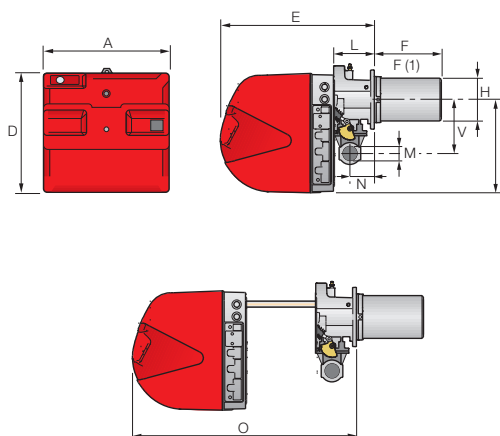

RS 50/M MZ

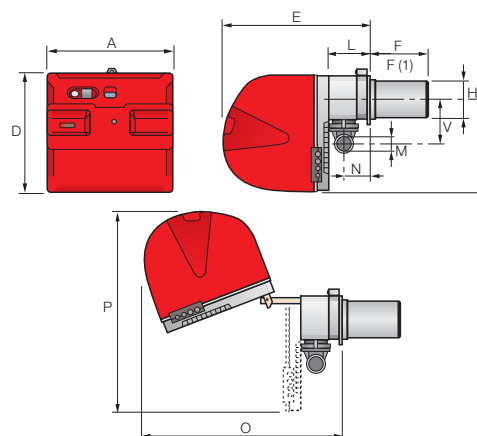

MODEL	A	D	E	F - F(1)	H	I	L	M	N	O	P	V
▶ RS 34/M MZ	442	422	508	216 - 351	140	305	138	1"1/2	84	780	-	177
▶ RS 44/M MZ	442	422	508	216 - 351	152	305	138	1"1/2	84	780	-	177
▶ RS 50/M MZ	476	474	580	216 - 351	152	352	164	1"1/2	108	810	719	168

(1) dimension with extended head

RS 64/M MZ

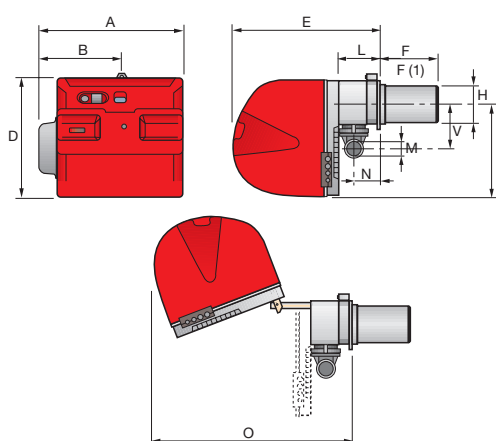

RS 70/M - 100/M - 130/M - 150/M - 190/M - 250/M MZ

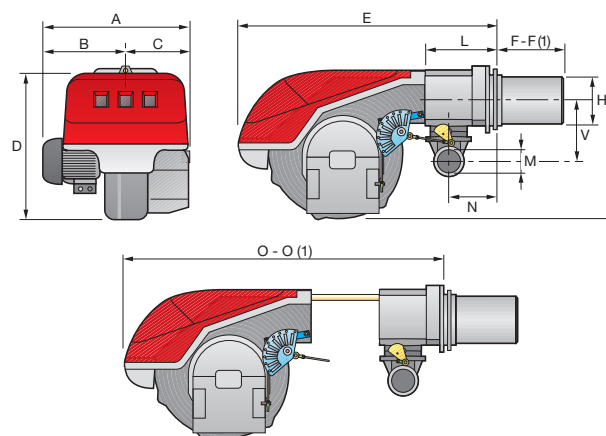

MODEL	A	B	C	D	E	F - F(1)	H	I	L	M	N	O - O(1)	V
▶ RS 64/M MZ	533	300	-	490	640	250 - 385	179	352	222	2"	134	870 - -	221
▶ RS 70/M	511	296	215	555	840	250 - 385	179	430	214	2"	134	1161 - 1296	221
▶ RS 100/M	527	312	215	555	840	250 - 385	179	430	214	2"	134	1161 - 1296	221
▶ RS 130/M	553	338	215	555	840	280 - 415	189	430	214	2"	134	1161 - 1296	221
▶ RS 150/M	675	370	305	590	840	280 - 415	189	435	214	2"	134	1180 - 1315	221
▶ RS 190/M	681	366	315	555	872	370 - 520	222	430	230	2"	150	1328 - -	221
▶ RS 250/M MZ	732	427	305	555	872	370 - 520	222	430	230	2"	150	1328 - -	262

(1) dimension with extended head

Modulating Gas Burners

RS/M SERIES

Overall dimensions (mm)

BURNER - BOILER MOUNTING FLANGE

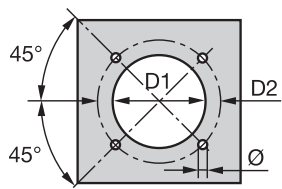

MODEL	D1	D2	Ø
▶ RS 34/M MZ	160	224	M8
▶ RS 44/M MZ	160	224	M8
▶ RS 50/M MZ	160	224	M8
▶ RS 64/M MZ	185	275-325	M12
▶ RS 70/M	185	275-325	M12
▶ RS 100/M	185	275-325	M12
▶ RS 130/M	195	275-325	M12
▶ RS 150/M	195	275-325	M12
▶ RS 190/M	230	325-368	M16
▶ RS 250/M MZ	230	325-368	M16

PACKAGING

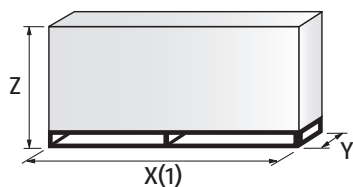

MODEL	X (1)	Y	Z	kg
▶ RS 34/M MZ	1000	485	500	32
▶ RS 44/M MZ	1000	485	500	33
▶ RS 50/M MZ	1200	502	520	41
▶ RS 64/M MZ	1200	580	520	42
▶ RS 70/M	1405	700	660	70
▶ RS 100/M	1405	700	660	73
▶ RS 130/M	1405	700	660	76
▶ RS 150/M	1400-1420	1000	660	110
▶ RS 190/M	1400-1420	1000	660	115
▶ RS 250/M MZ	1400-1420	1040	725	117

(1) dimension with standard and extended head

Specification

DESIGNATION OF SERIES

Series:	R
Fuel:	S Natural Gas L Light oil LS Light oil/Natural Gas N Heavy oil
Size:	
Setting:	/1 Single stage /B Two stage /M Modulating-Mechanical cam /E Electronic cam /P Proportioning air/gas valve /EV Electronic cam predisposed for variable speed (with inverter) /EVi Electronic cam with integrated inverter
Emission:	... or C01 Class 1 EN676 MZ Class 2 EN676 BLU Class 3 EN676 MX Class 3 EN676
Head length:	TC standard head TL extended head
Flame control system:	FS1 Standard/Intermittent (at least 1 stop every 24 h) FS2 Continuous (1 stop every 72 h)
Electrical supply to the system:	1/230/50 1/230V/50Hz 3/230/50 3/230V/50Hz 3/400/50 3N/400V/50Hz 3/230-400/50 3/230V/50Hz - 3N/400V/50Hz 3/220/60 3/220V/60Hz 3/380/60 3N/380V/60Hz 3/220-380/60 3/220/60Hz - 3N/380V/60Hz
Auxiliary voltage:	230/50-60 230V/50-60H 110/50-60 110V/50-60Hz

R S 50 /M MZ TC FS1 3/230-400/50 230/50-60

BASIC DESIGNATION

EXTENDED DESIGNATION

Specification

STATE OF SUPPLY

RS 34/M MZ – 44/M MZ models

Monoblock forced draught gas burner with two stage progressive or modulating operation, with a specific kit, fully automatic, made up of:

- Air suction circuit **with sound proofing material**
- High performance fan with straight blades
- Air damper for air flow setting and butterfly valve for regulating fuel output controlled by a servomotor with variable cam
- Starting motor at 2800 rpm, single-phase / 230V / 50-60Hz or three-phase / 230-400V / 50-60Hz
- Combustion head, that can be set on the basis of required output, fitted with:
 - stainless steel end cone, resistant to corrosion and high temperatures
 - ignition electrodes
 - ionisation probe
 - gas distributor
 - flame stability disk
- Exclusive patented HCS (Housing Cooling System) with high thermal insulation and air circulation with continuous air volume refresh for an active cooling system and avoid heat transfer to the electrical component housing
- Minimum air pressure switch stops the burner in case of insufficient air quantity at the combustion head
- Microprocessor-based burner safety control box, with diagnostic functions
- Plugs and Sockets for electrical connection, accessible from the external of the cover
- Burner on/off selection switch
- Manual or automatic output increase/decrease selection switch
- Flame inspection window
- Slide bars for easier installation and maintenance
- Protection filter against radio interference
- IP 40 electric protection level.

Standard equipment:

- 1 gas train flange
- 1 flange gasket
- 4 screws for fixing the flange
- 1 thermal screen
- 4 screws for fixing the burner flange to the boiler
- 3 plugs for electrical connection (RS 34-44/M MZ single-phase)
- 4 plugs for electrical connection (RS 44/M MZ three-phase)
- Instruction handbook for installation, use and maintenance
- Spare parts catalogue.

RS/M SERIES

Specification

STATE OF SUPPLY

RS 50/M MZ – 64/M MZ – 70/M – 100/M – 130/M – 150/M – 190/M – 250/M MZ models

Monoblock forced draught gas burner with two stage progressive or modulating operation, with a specific kit, fully automatic, made up of:

- Air suction circuit lined with sound-proofing material
- Fan with reverse curve blades (RS 50 – 70 – 100 – 130/M models) or straight blades (RS 64/M MZ – 150/M – 190/M – 250/M MZ models)
- Air damper for air flow setting and butterfly valve for regulating fuel output controlled by a servomotor with variable cam
- Starting motor at 2800 rpm, three-phase 400V with neutral, 50Hz
- Combustion head, that can be set on the basis of required output, fitted with:
 - stainless steel end cone, resistant to corrosion and high temperatures
 - ignition electrodes
 - ionisation probe
 - gas distributor
 - flame stability disk
- Maximum gas pressure switch to stop the burner in the case of excess pressure on the fuel supply line
- Minimum air pressure switch stops the burner in case of insufficient air quantity at the combustion head
- Microprocessor-based burner safety control box, with diagnostic functions
- Burner on/off selection switch
- Manual or automatic output increase/decrease selection switch
- Flame inspection window
- Slide bars for easier installation and maintenance
- Protection filter against radio interference
- IP 44 electric protection level.

Standard equipment:

- 1 gas train flange
- 1 flange gasket
- 4 screws for fixing the flange
- 1 thermal screen
- 4 screws for fixing the burner flange to the boiler
- Wiring loom fittings for the electrical connection (RS 64-50/M MZ)
- 2 slide bar extensions (for extended head models and RS 150-190/M models)
- Instruction handbook for installation, use and maintenance
- Spare parts catalogue.

Modulating Gas Burners

RS/M SERIES

Available models

Burners

CODE	MODEL				HEAT OUTPUT		TOTAL ELECTRICAL POWER (kW)	CERTIFICATION	NOTE
					NATURAL GAS				
					(kW)	(Nm ³ /h)			
3788710	RS 34/M MZ	TC	FS1 1/230/50-60	230/50-60	45/125÷390	4,5/12,5÷39	0,6	CE 0085BR0378	(1)(5)
3788711	RS 34/M MZ	TL	FS1 1/230/50-60	230/50-60	45/125÷390	4,5/12,5÷39	0,6	CE 0085BR0378	(1)(5)
3788810	RS 44/M MZ	TC	FS1 1/230/50-60	230/50-60	80/203÷550	8/20,3÷55	0,7	CE 0085BR0378	(1)(5)
3788811	RS 44/M MZ	TL	FS1 1/230/50-60	230/50-60	80/203÷550	8/20,3÷55	0,7	CE 0085BR0378	(1)(5)
3788840	RS 44/M MZ	TC	FS1 3/230-400/50-60	230/50-60	80/203÷550	8/20,3÷55	0,75	CE 0085BR0378	(1)(5)
3788841	RS 44/M MZ	TL	FS1 3/230-400/50-60	230/50-60	80/203÷550	8/20,3÷55	0,75	CE 0085BR0378	(1)(5)
3781622	RS 50/M MZ	TC	FS1 3/230-400/50	230/50-60	80/285÷630	8/29÷63	0,75	CE 0085AQ0709	(1)(5)
3781623	RS 50/M MZ	TL	FS1 3/230-400/50	230/50-60	80/285÷630	8/29÷63	0,75	CE 0085AQ0709	(1)(5)
3781682	RS 50/M MZ	TC	FS1 3/220-380/60	230/50-60	80/285÷630	8/29÷63	0,66	-	(1)(5)
3781683	RS 50/M MZ	TL	FS1 3/220-380/60	230/50-60	80/285÷630	8/29÷63	0,66	-	(1)(5)
3788910	RS 64/M MZ	TC	FS1 3/230-400/50	230/50-60	150/400÷850	15/40÷85	1,5	CE 0085BR0558	(1)(5)
3788911	RS 64/M MZ	TL	FS1 3/230-400/50	230/50-60	150/400÷850	15/40÷85	1,5	CE 0085BR0558	(1)(5)
3788980	RS 64/M MZ	TC	FS1 3/220-380/60	230/50-60	150/400÷850	15/40÷85	1,5	-	(1)(5)
3789610	RS 70/M	TC	FS1 3/230-400/50	230/50-60	150/470÷930	15/47÷93	1,4	CE 0085AQ0708	(2)(5)
3789611	RS 70/M	TL	FS1 3/230-400/50	230/50-60	150/470÷930	15/47÷93	1,4	CE 0085AQ0708	(2)(5)
20147189	RS 70/M	TC	FS1/FS2 3/230-400/50	230/50-60	150/470÷930	15/47÷93	1,4	CE 0085AQ0708	(2)(3)(6)
3787082	RS 70/M	TC	FS1 3/220-380/60	230/50-60	150/470÷930	15/47÷93	1,4	-	(2)(5)
3787083	RS 70/M	TL	FS1 3/220-380/60	230/50-60	150/470÷930	15/47÷93	1,4	-	(2)(5)
3789710	RS 100/M	TC	FS1 3/230-400/50	230/50-60	150/700÷1340	15/70÷134	1,8	CE 0085AQ0708	(2)(5)
3789711	RS 100/M	TL	FS1 3/230-400/50	230/50-60	150/700÷1340	15/70÷134	1,8	CE 0085AQ0708	(2)(5)
20147191	RS 100/M	TC	FS1/FS2 3/230-400/50	230/50-60	150/700÷1340	15/70÷134	1,8	CE 0085AQ0708	(1)(3)(6)
3787282	RS 100/M	TC	FS1 3/220/380-460/60	230/50-60	150/700÷1340	15/70÷134	2,1	-	(2)(5)
3787283	RS 100/M	TL	FS1 3/220/380-460/60	230/50-60	150/700÷1340	15/70÷134	2,1	-	(2)(5)
3789810	RS 130/M	TC	FS1 3/230-400/50	230/50-60	254/920÷1600	24/92÷160	2,6	CE 0085AQ0708	(2)(5)
3789811	RS 130/M	TL	FS1 3/230-400/50	230/50-60	254/920÷1600	24/92÷160	2,6	CE 0085AQ0708	(2)(5)
20147219	RS 130/M	TC	FS1/FS2 3/230-400/50	230/50-60	254/920÷1600	24/92÷160	2,6	CE 0085AQ0708	(1)(3)(6)
3787482	RS 130/M	TC	FS1 3/220/380-460/60	230/50-60	254/920÷1600	24/92÷160	2,6	-	(2)(5)
3787483	RS 130/M	TL	FS1 3/220/380-460/60	230/50-60	254/920÷1600	24/92÷160	2,6	-	(2)(5)
20044638	RS 150/M	TC	FS1 3/400/50	230/50-60	300/900÷1850	30/90÷185	3,5	CE 0085CS0427	(2)(5)
20044639	RS 150/M	TL	FS1 3/400/50	230/50-60	300/900÷1850	30/90÷185	3,5	CE 0085CS0427	(2)(5)

RS/M SERIES

Available models

Burners

CODE	MODEL				HEAT OUTPUT		TOTAL ELECTRICAL POWER (kW)	CERTIFICATION	NOTE
					NATURAL GAS				
					(kW)	(Nm ³ /h)			
3787623	RS 190/M	TC	FS1 3/400/50	230/50-60	470/1279-2290	47/128-229	5,5	CE 0085AT0042	(2)(5)
3787622	RS 190/M	TC	FS1 3/230/50	230/50-60	470/1279-2290	47/128-229	5,5	CE 0085AT0042	(2)(5)
20147220	RS 190/M	TC	FS1/FS2 3/400/50	230/50-60	470/1279-2290	47/128-229	5,5	CE 0085AT0042	(1)(3)(6)
20052616	RS 190/M	TL	FS1 3/400/50	230/50-60	470/1279-2290	47/128-229	5,5	CE 0085AT0042	(1)(5)
20147222	RS 190/M	TC	FS1/FS2 3/230/50	230/50-60	470/1279-2290	47/128-229	5,5	CE 0085AT0042	(1)(3)(6)
3787682	RS 190/M	TC	FS1 3/380/60	220/60	470/1279-2290	47/128-229	5,5	-	(2)(5)
3787681	RS 190/M	TC	FS1 3/220/60	220/60	470/1279-2290	47/128-229	5,5	-	(2)(5)
3788410	RS 250/M MZ	TC	FS1 3/400/50	230/50-60	600/1250÷2650	60/125÷265	6,5	CE 0085BS0114	(2)(5)
3788411	RS 250/M MZ	TL	FS1 3/400/50	230/50-60	600/1250÷2650	60/125÷265	6,5	CE 0085BS0114	(2)(5)
3788440	RS 250/M MZ	TC	FS1 3/230/50	230/50-60	600/1250÷2650	60/125÷265	6,5	CE 0085BS0114	(2)(5)
20145630	RS 250/M MZ	TC	FS1/FS2 3/230-380/60	220/60	600/1250÷2650	60/125÷265	6,5	-	(2)(3)(6)

Due to the improvement applied on the technical specification of some products, some burner codes will change during year 2019. The table below summarizes the correspondence between the previous and the new code.

MODEL				NEW CODE	OLD CODE
RS 70/M	TC	FS1/FS2 3/230-400/50	230/50-60	20147189 (3)(6)	3866203 (4)
RS 100/M	TC	FS1/FS2 3/230-400/50	230/50-60	20147191 (3)(6)	3866204 (4)
RS 130/M	TC	FS1/FS2 3/230-400/50	230/50-60	20147219 (3)(6)	3866205 (4)
RS 190/M	TC	FS1/FS2 3/230/50	230/50-60	20147222 (3)(6)	20011708 (4)
RS 250/M MZ	TC	FS1/FS2 3/230-380/60	220/60	20145630 (3)(6)	20008162 (4)

Natural Gas, net calorific value: 10 kWh/Nm³ - Density at 20°C: 0,71 kg/Nm³

The burners of RS/M series are in according to 2016/426/EU - 2014/30/EU - 2014/35/EU - 2006/42 CE Directive and EN 676 Norm.

(1) With plug and socket.

(2) With terminal board.

(3) With RFGO control box.

(4) With LFL control box.

(5) With RMG/M control box.

(6) FS2 operation is allowed with ionization probe only, no other flame sensors can be used.

Please contact Riello Burners Commercial and Technical Department, our Application Engineers will be pleased to help you.

Modulating Gas Burners

RS/M SERIES

Available models

Gas Trains

CODE	GAS TRAIN			VPS CODE	ADAPTER CODE								
	MODEL	Ø	C.T.		RS 34	RS 44-50	RS 64	RS 70	RS 100	RS 130	RS 150	RS 190	RS 250
3970500*	MB 405/1 - RT 20	Rp 3/4"	-	3010123	3000824	●	●	●	●	●	●	●	
3970553*	MB 407/1 - RT 20	Rp 3/4"	-	3010123		●	●	●	●	●	●	●	
3970599*	MB 407/1 - RT 52	Rp 3/4"	-	3010123		●	●	●	●	●	●	●	
3970229*	MB 407/1 - RSM 20	Rp 3/4"	-	3010123		●	●	●	●	●	●	●	
3970258*	MB 410/1 - RT 52	Rp 1" 1/4	-	3010123	3010124	3000843		●	●	●	●	●	
3970554*	MB 410/1 - RT 20	Rp 3/4"	-	3010123	3000824	3000824 + 3000843	●	●	●	●	●	●	
3970600*	MB 410/1 - RT 52	Rp 3/4"	-	3010123			●	●	●	●	●	●	●
3970230*	MB 410/1 - RSM 20	Rp 3/4"	-	3010123			●	●	●	●	●	●	●
3970256*	MB 412/1 - RT 52	Rp 1" 1/2	-	3010123	□	□	3000843						
3970144*	MB 412/1 - RT 20	Rp 1" 1/2	-	3010123	□	□							
3970197**	MB 412/1 CT RT 20	Rp 1" 1/2	◆	-	□	□							
3970231*	MB 412/1 - RSM 20	Rp 1" 1/2	-	3010123	□	□							
3970180*	MB 415/1 - RT 30	Rp 1" 1/2	-	3010123	□	□							
3970198**	MB 415/1 CT RT 30	Rp 1" 1/2	◆	-	□	□							
3970250*	MB 415/1 - RT 52	Rp 1" 1/2	-	3010123	□	□							
3970253**	MB 415/1 CT RT 52	Rp 1" 1/2	◆	-	□	□							
3970232*	MB 415/1 - RSM 30	Rp 1" 1/2	-	3010123	□	□							
3970181*	MB 420/1 - RT 30	Rp 2"	-	3010123	□	□							□
3970182**	MB 420/1 CT RT 30	Rp 2"	◆	-	□	□	□	□	□	□	□		
3970257*	MB 420/1 - RT 52	Rp 2"	-	3010123	3000822	□	□	□	□	□	□	□	
3970252**	MB 420/1 CT RT 52	Rp 2"	◆	-		□	□	□	□	□	□	□	
3970233*	MB 420/1 - RSM 30	Rp 2"	-	3010123		□	□	□	□	□	□	□	
3970234**	MB 420/1 CT RSM 30	Rp 2"	◆	-		□	□	□	□	□	□	□	
3970221*	MBC 1200/1 - RSM 60	Rp 2"	-	3010123		□	□	□	□	□	□	□	
3970225**	MBC 1200/1 CT RSM 60	Rp 2"	◆	-		□	□	□	□	□	□	□	
3970222*	MBC 1900/1 - FSM 40	DN 65	-	3010123	●	●	3000825						
3970226**	MBC 1900/1 CT FSM 40	DN 65	◆	-	●	●	3000826						
3970223*	MBC 3100/1 - FSM 40	DN 80	-	3010123	●	●	3000826						
3970227**	MBC 3100/1 CT FSM 40	DN 80	◆	-	●	●	3000826						
3970224	MBC 5000/1 - FSM 80	DN 100	-	3010123	●	●	●	●	●	●	●	3010370 + 3000826	
3970228	MBC 5000/1 CT FSM 80	DN 100	◆	-	●	●	●	●	●	●	●	3000826	
3970145*	CB 512/1 - RSM 30	Rp 1" 1/2	-	3010123	□	□	3000843						
20045589**	CB 512/1 CT RSM 30	Rp 1" 1/2	◆	-	□	□	3000843						
3970146*	CB 520/1 - RSM 30	Rp 2"	-	3010123	3000822	□	□	□	□	□	□	□	
3970160**	CB 520/1 CT RSM 30	Rp 2"	◆	-		□	□	□	□	□	□	□	
20044659*	CB 525/1 - RSM 30	Rp 2"	-	3010123		□	□	□	□	□	□	□	
20044660**	CB 525/1 CT RSM 30	Rp 2"	◆	-		□	□	□	□	□	□	□	
3970147*	CB 5065/1 - FSM 30	DN 65	-	3010123	●	3000825							
3970161**	CB 5065/1 CT FSM 30	DN 65	◆	-	●	3000825							
3970148*	CB 5080/1 - FSM 30	DN 80	-	3010123	●	●	3000826						
3970162**	CB 5080/1 CT FSM 30	DN 80	◆	-	●	●	3000826						
3970149*	CB 50100/1 - FSM 30	DN 100	-	3010123	●	●	3010370 + 3000826						
3970163**	CB 50100/1 CT FSM 30	DN 100	◆	-	●	●	3010370 + 3000826						
20015871*	CB 50125/1 - FSM 30	DN 125	-	3010123	●	●	●	●	3010224 + 3000826				
3970196**	CB 50125/1 CT FSM 30	DN 125	◆	-	●	●	●	●	3010224 + 3000826				

Please see designation of Gas Train Series in the page before the Catalogue index.

* 230V/50Hz - 220V/60Hz electrical supply.

** 230V/50Hz electrical supply.

The valve seal control device is compulsory (conforming to EN 676) on gas trains to burners with a maximum output over 1200 kW.

To select the gas train please refer to the technical data leaflet and/or instruction manual.

C.T. Gas valve leak detection control device:

- gas train not equipped with leak detection control device; this device can be ordered separately - see VPS column - and installed later.

◆ gas train equipped with leak detection control device.

VPS Valve leak detection control device. Supplied separately from the gas train (please see Gas train accessories paragraph for both 50 Hz and 60 Hz codes).

● Not available.

□ Additional adapter not necessary, the gas train may be connected directly to the burner.

Burner accessories

Extended heads

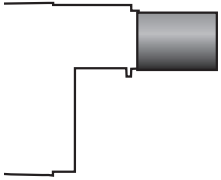

“Standard head” burners can be transformed into “extended head” versions, by using the special kit. The KITS available for the various burners, giving the original and the extended lengths, are listed below.

BURNER	'STANDARD HEAD' LENGTH (mm)	'EXTENDED HEAD' LENGTH (mm)	KIT CODE
▶ RS 34/M MZ	216	351	3010428
▶ RS 44/M MZ	216	351	3010429
▶ RS 50/M MZ	216	351	3010078
▶ RS 64/M MZ	250	385	3010427
▶ RS 70/M	250	385	3010117
▶ RS 100/M	250	385	3010118
▶ RS 130/M	280	415	3010119
▶ RS 150/M	280	415	20052186
▶ RS 190/M	370	520	3010443 *
▶ RS 250/M MZ	370	520	3010412

* Kit to be used on burners recognizable by a serial number that is over or equal to 02426XXXXXX, for burners with a serial number that is under or equal to 02416XXXXXX please use the Kit coded 3010196

Spacer kit

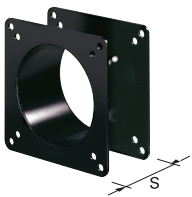

If burner head penetration into the combustion chamber needs reducing, varying thickness spacers are available, as given in the following table:

BURNER	SPACER THICKNESS S (mm)	KIT CODE
▶ RS 34/M MZ - 44/M MZ - RS 50/M MZ	110	3010095
▶ RS 64/M MZ - RS 70/M - 100/M - 130/M - 150/M	135	3010129
▶ RS 190/M - 250/M MZ	102	3000722

Continuous ventilation kit



If the burner requires continuous ventilation in the stages without flame, a special kit is available as given in the following table:

BURNER	KIT CODE
▶ RS 34/M MZ - 44/M MZ	3010449
▶ RS 50/M MZ - 64/M MZ - 70/M - 100/M - 130/M - 150/M - 190/M - 250/M	3010094

Modulating Gas Burners

RS/M SERIES

Burner accessories

Accessories for modulating operation



To obtain modulating operation, the RS/M series of burners requires a regulator with three point outlet controls. The relative temperature or pressure probes fitted to the regulator must be chosen on the basis of the application.

The following table lists the accessories for modulating operation with their application range.

For remote setpoint use RWF 55.

BURNER	TYPE	KIT CODE
▶ RS 34/M MZ - 44/M MZ	RWF 50.2	20083339
	RWF 55.5	20098541
▶ RS 50/M MZ - RS 64/M MZ	RWF 50.2	20082208
	RWF 55.5	20099657
▶ RS 70/M - 100/M - 130/M - 150/M - 190/M - 250/M MZ	RWF 50.2	20099869
	RWF 55.5	20099905

PROBE



BURNER	PROBE TYPE	RANGE (°C) (bar)	KIT CODE
▶ All models	Temperature PT 100	-100 ÷ 500°C	3010110
	Pressure 4 ÷ 20 mA	0 ÷ 2,5 bar	3010213
	Pressure 4 ÷ 20 mA	0 ÷ 16 bar	3010214
	Pressure 4 ÷ 20 mA	0 ÷ 25 bar	3090873

ANALOG CONTROL SIGNAL CONVERTER



Modulating operation can also be obtained with an analog control signal converter and a feedback three-pole potentiometer.

Alternatively, the potentiometer can be used to check the servomotor position.

BURNER	TYPE (INPUT SIGNAL)	KIT CODE
▶ RS 34/M MZ - 44/M MZ	0/2 - 10 V (impedance 200 KΩ)	3010410
	0/4 - 20 mA (impedance 250 Ω)	
▶ RS 50/M MZ - RS 64/M MZ	0/2 - 10 V (impedance 200 KΩ)	-
	0/4 - 20 mA (impedance 250 Ω)	
▶ RS 70/M - 100/M - 130/M 150/M - RS 190/M - 250/M MZ	0/2 - 10 V (impedance 200 KΩ)	3010415
	0/4 - 20 mA (impedance 250 Ω)	

Burner accessories

Potentiometer kit

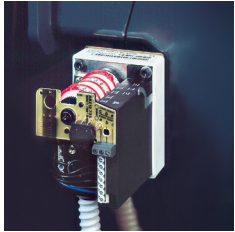

BURNER	KIT CODE
▶ RS 34/M MZ - 44/M MZ	3010420
▶ RS 50/M MZ - RS 64/M MZ	3010109
▶ RS 70/M - 100/M - 130/M - 150/M - 190/M - 250/M MZ	3010416

Connection flange kit

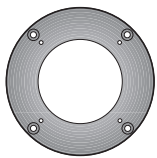

A kit is available for use where the burner opening on the boiler is of excessive diameter.

BURNER	KIT CODE
▶ RS 34/M MZ - 44/M MZ - RS 50/M MZ	3010138

LPG kit

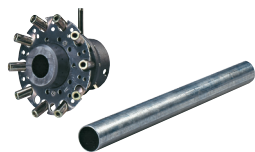

For burning LPG gas, a special kit is available to be fitted to the combustion head on the burner, as given in the following table:

BURNER	KIT CODE FOR 'STANDARD HEAD'	KIT CODE FOR 'EXTENDED HEAD'
▶ RS 34/M MZ	3010423	3010423
▶ RS 44/M MZ	3010424	3010424
▶ RS 50/M MZ	20008173	20008173
▶ RS 64/M MZ	3010434	3010435
▶ RS 70/M	20008175	20008176
▶ RS 100/M	20008177	20008178
▶ RS 130/M	20008179	20008180
▶ RS 150/M	20050064	20050065
▶ RS 190/M	3010166	3010166
▶ RS 250/M MZ	3010411	3010411

Town gas kit



For burning Town gas, a special kit is available:

BURNER	KIT CODE FOR 'STANDARD HEAD' (*)	KIT CODE FOR 'EXTENDED HEAD' (*)
▶ RS 34/M MZ	3010502	3010502
▶ RS 44/M MZ	3010503	3010503
▶ RS 50/M MZ	3010285	3010285
▶ RS 70/M	3010286	3010286
▶ RS 100/M	3010287	3010287
▶ RS 130/M	3010288	3010288
▶ RS 190/M	3010297	3010297
▶ RS 250/M MZ	3010472	3010472

(*) Without CE certification

Modulating Gas Burners

RS/M SERIES

Burner accessories

Vibration reduction kit



The kit allow you to improve flame stability in some applications, where the boiler/flue assembly is liable to resonate.

BURNER	KIT CODE	NOTE
▶ RS 34/M MZ (Natural Gas)	20098750	(1)
▶ RS 34/M MZ (LPG)	20098753	(2)
▶ RS 44/M MZ (Natural Gas)	20098746	(1)
▶ RS 50/M MZ TC – RS 50/M MZ TL	3010200	(1)
▶ RS 70/M TC – RS 70/M TL	3010201	(1)
▶ RS 100/M TC – RS 100/M TL	3010202	(1)
▶ RS 130/M TC	3010373	(1)
▶ RS 130/M TL	3010374	(1)
▶ RS 190/M TC	3010375	(1)

(1) CE approved
 (2) CE approval on field is required

Ground fault interrupter kit



A "Ground fault interrupter kit" is available as a safety device for electrical system fault.

BURNER	KIT CODE
▶ RS 34/M MZ – 44/M MZ	3010448
▶ RS 50/M MZ – RS 64/M MZ	3010321
▶ RS 70/M – 100/M – 130/M – 150/M – 190/M – RS 250/M MZ	3010329

Gas max pressure switch kit

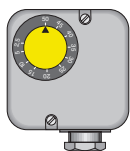

If necessary a Gas max pressure Switch kit is available and connectable to the burner electrical wiring through Plugs & Sockets system.

BURNER (*)	KIT CODE
▶ RS 34/M MZ – 44/M MZ	3010418

(*) Gas max pressure switch is installed as a standard on RS 50/M MZ – 64/M MZ – 70/M – 100/M – 130/M – 190/M – 250/M MZ

Volt free contact kit



A volt free contact kit is available for installation onto the burner. It can be used for a remote interface between burner operating signals. Every burner can be equipped with a single kit for a remote check of the flame presence signal or the burner lockout indication.

BURNER	KIT CODE
▶ RS 34/M MZ – 44/M MZ – 50/M MZ – 64/M MZ	3010419

Burner accessories

PC interface kit



To connect the RMG control box to a personal computer for the transmission of operation, fault signals and detailed service information, an interface adapter with PC software are available.

BURNER	KIT CODE
► All models	3002719

DN80 gas flange kit

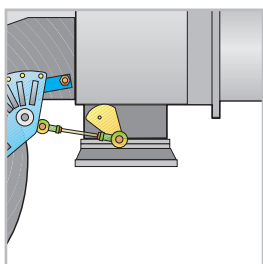

To modify the standard 2" burner gas input connection in to DN80 connection, a specific gas flange is available.

BURNER	KIT CODE
► All models	3010439

Post-ventilation kit

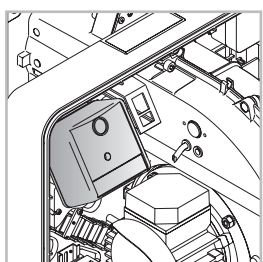

To have 20 s ventilation after opening of thermostats chain, a special kit is available.

BURNER	KIT CODE
► RS 34/M MZ - 44/M MZ	3010451

Hours counter kit

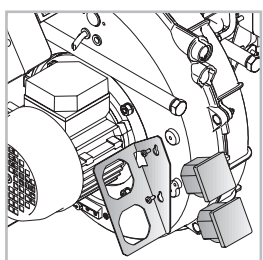

To measure the burner working time a hours counter kit is available.

BURNER	KIT CODE
► RS 34/M MZ - 44/M MZ	3010450

Modulating Gas Burners

RS/M SERIES

Burner accessories

Protection kit (electromagnetic interferences)

When the burner is installed in a room particularly subject to electromagnetic interference (signals emitted over 10 V/m) due for example to INVERTER presence or in systems where the lengths of the thermostat connections is over 20 meters, this specific protection kit is available as an interface between the thermostatic controls and the burner.

BURNER	KIT CODE
► All models	3010386

Head kit for “reverse flame chamber”



In certain cases, the use of the burner on reverse flame boilers can be improved by using an additional cylinder.

BURNER	STANDARD HEAD LENGTH WITH CYLINDER (mm)	EXTENDED HEAD LENGTH WITH CYLINDER (mm)	KIT CODE (*)
► RS 190/M	493	-	3010241

(*) CE approval on field is required

Sound proofing box

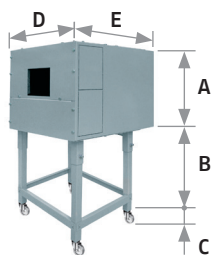

If noise emission needs reducing even further, sound-proofing boxes are available. When a lower “B” dimension is required, it is available the Box Support Kit code 20065135 which allows to reduce it at the fixed dimension of 55 mm. The sound-proofing boxes are not suitable for outdoor use.

BURNER	BOX TYPE	A (mm)	B (mm) min-max	C (mm)	D (mm)	E (mm)	[dB(A)] (*)	BOX CODE
► RS 34/M MZ – 44/M MZ – RS 50/M MZ – RS 64/M MZ	C1/3	650	372 – 980	110	690	770	10	3010403
► RS 70/M – 100/M – 130/M								
► RS 150/M – 190/M	C4/5	850	160 – 980	110	980	930	10	3010404
RS 250/M MZ								

(*) Average noise reduction according to EN 15036-1 standard

Uv Flame sensor



UV90L flame sensor can be used only with the RFG0 control box and when the LFL control box with UV flame sensor type QRA2 must be replaced.







BURNER	KIT CODE
► All RS/M models (*)	On demand

(*) Only with RFG0 control box.

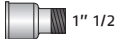
Gas train accessories

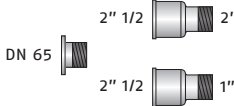
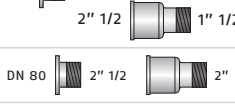
Adapters

In certain cases, an adapter must be fitted between the gas train and the burner, when the diameter of the gas train is different from the set diameter of the burner. Below are given the available adapters; please see on the Gas Train list the correct adapter codes to select.

ADAPTER	LENGTH mm	ADAPTER CODE
 2" 1" 1/2	70	3000822
 3/4" 1" 1/2	31	3000824
 DN 65 2" 1/2 2"	300	3000825
 DN 80 2" 1/2 2"	300	3000826
 1" 1/2 2"	35	3000843
 1" 1/4 1" 1/2	35	3010124
 1" 1/4 2"	35	3010126

Stabiliser spring



Accessory springs are available to vary the pressure range of the gas train stabilisers. The following table shows these accessories with their application range. Please refer to the technical manual for the correct choice of spring.

GAS TRAIN	SPRING COLOUR	SPRING PRESSURE RANGE mbar	SPRING CODE
▶ MBC 1900/1 - 3100/1 MBC 5000/1	White	4 - 20	3010381
	Red	20 - 40	3010382
	Black	40 - 80	3010383
	Green	80 - 150	3010384
▶ CB 512/1	Red	25 - 55	3010131
	Black	60 - 110	3010157
	Pink	90 - 150	3090486
▶ CB 520/1 - 525/1	Red	25 - 55	3010132
	Black	60 - 110	3010158
	Pink	100 - 150	3090487
▶ CB 5065/1 - 5080/1	Red	25 - 55	3010133
	Black	60 - 110	3010135
	Pink	100 - 150	3090456
	Grey	140 - 200	3090992

Modulating Gas Burners

RS/M SERIES

Gas train accessories

Seal control kit



To test the valve seals on the gas train, a special "seal control kit" is available. The valve seal control device is compulsory (EN 676) on gas trains to burners with a maximum output over 1200 kW. The seal control is type VPS 504.

GAS TRAIN	KIT CODE for 50 Hz operation	KIT CODE for 60 Hz operation
▶ MB/1 type	3010123	20168805
▶ MBC/1 type	3010123	20168805
▶ CB/1 type	3010123	20168805

RS/E-EV MZ SERIES

The RS/E-EV MZ burners series covers a firing range from 44 to 2650 kW, and it is based on a new Digital Burner Management System, Riello REC27, which is able to manage the air-fuel ratio by independent servomotors in order to obtain a perfect output control and to assure a correct combustion and safe operation on all modulation range. Operation can be "two stage progressive" or, alternatively, "modulating" with the installation of a PID logic regulator and respective probes. RS/E MZ burners series guarantees high efficiency levels in all the various applications, thus reducing fuel consumption and running costs.

The RS 250/EV MZ model, equipped with REC37, is available to operate with **Variable Speed Drive technology** base on the control of a Frequency Inverter that modifies the air flow through the motor speed variation.

Optimisation of sound emissions is guaranteed by the special design of the air suction circuit and by incorporated sound proofing material.

Guidelines for installation of burners in conformity to EU Regulation:

A RIELLO burner (Heat Generator), where it is matched with a water-based boiler (Heater Housing) with a nominal output ≤ 400 kW, providing heat for heating purposes and heat to deliver sanitary hot water, can be installed:

- With boilers (heater housings) already in service in the field, for replacement of identical products, in conformity to Article 1, paragraph 2, point (G) of the EU Regulation No. 813/2013;
- With boilers (heater housings) on a new installation.

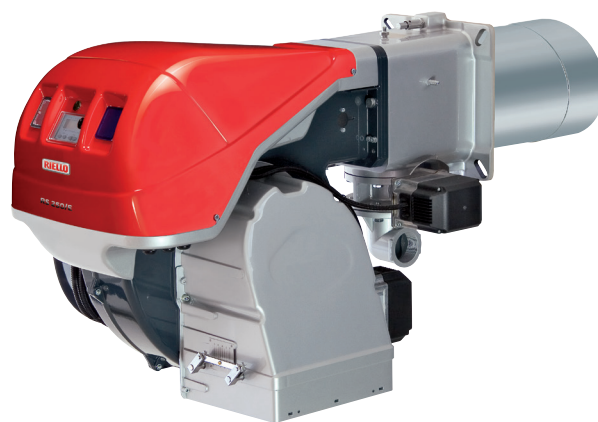

RS 34/E MZ	44/130 ÷	390 kW
RS 44/E MZ	80/200 ÷	550 kW
RS 50/E MZ	85/290 ÷	580 kW
RS 64/E MZ	150/400 ÷	850 kW
RS 70/E	135/465 ÷	814 kW
RS 100/E	150/698 ÷	1163 kW
RS 130/E	254/920 ÷	1600 kW
RS 190/E-EV	470/1279 ÷	2290 kW
RS 250/E-EV MZ	600/1250 ÷	2650 kW

FIRING RATES

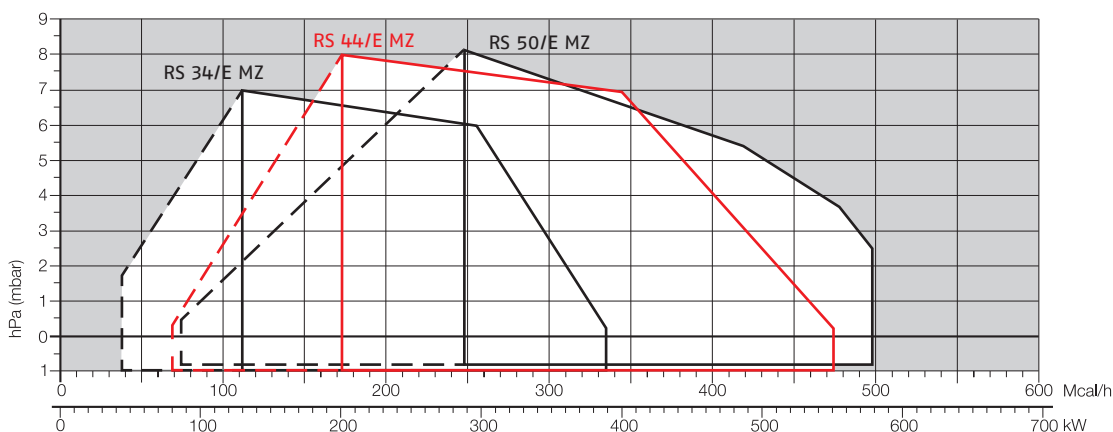

 Useful working field for choosing the burner

 Modulation range

Test conditions conforming to EN676
 Temperature: 20°C
 Pressure: 1013,5 mbar
 Altitude: 0 m a.s.l.

Modulating Gas Burners

RS/E-EV MZ SERIES

FIRING RATES

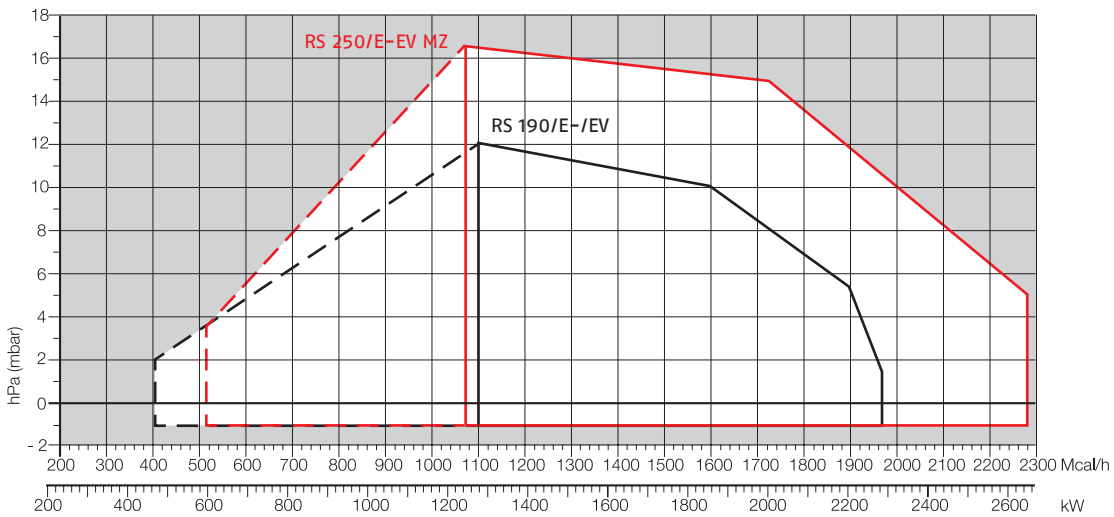
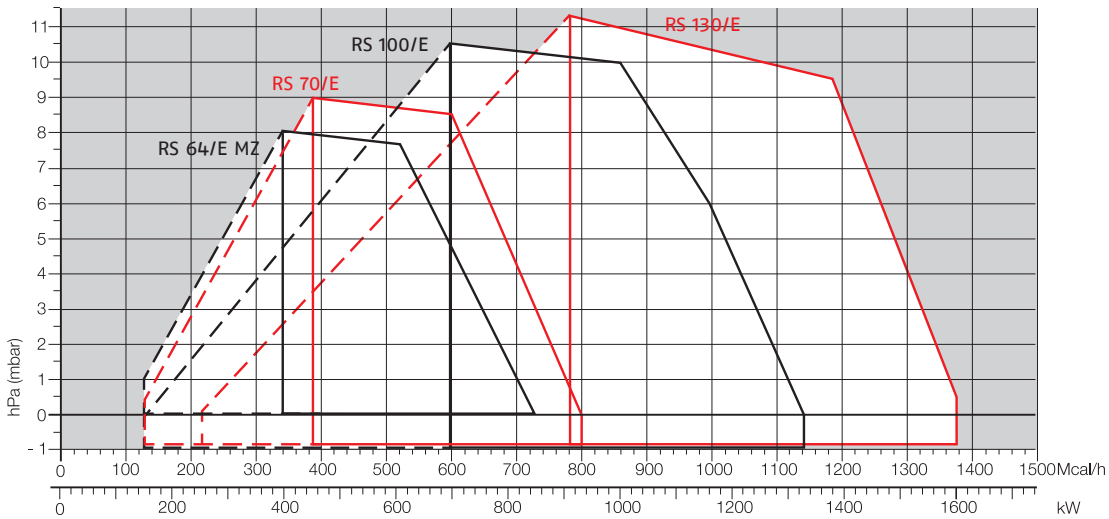

Overall dimensions (mm)

BURNER

RS 34-44/E MZ

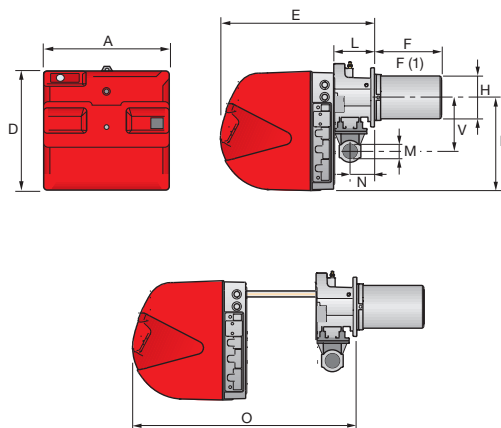

RS 50/E MZ

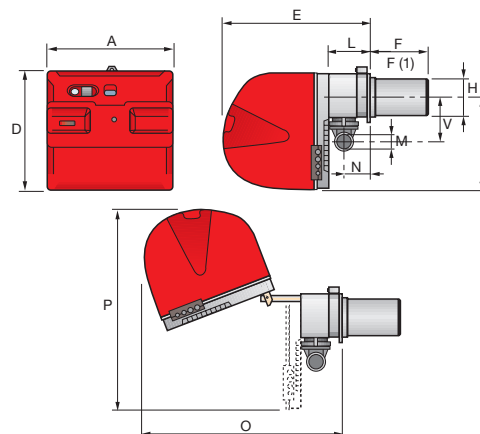

MODEL	A	D	E	F - F(1)	H	I	L	M	N	O	P	V
▶ RS 34/E MZ	442	422	508	216 - 351	140	305	138	1 1/2	84	780	-	177
▶ RS 44/E MZ	442	422	508	216 - 351	152	305	138	1 1/2	84	780	-	177
▶ RS 50/E MZ	476	474	580	216 - 351	152	352	164	1 1/2	108	810	719	168

(1) dimension with extended head

RS 64/E MZ

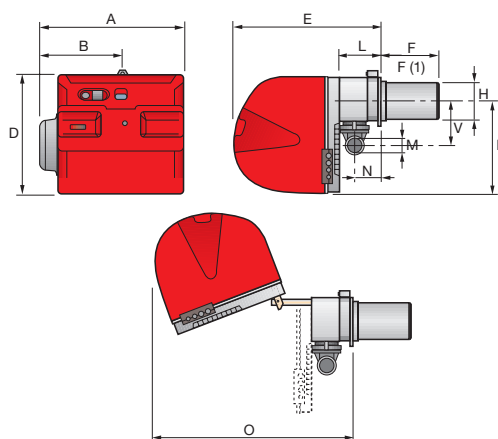

RS 70-100-130-190/E - RS 250/E-EV MZ

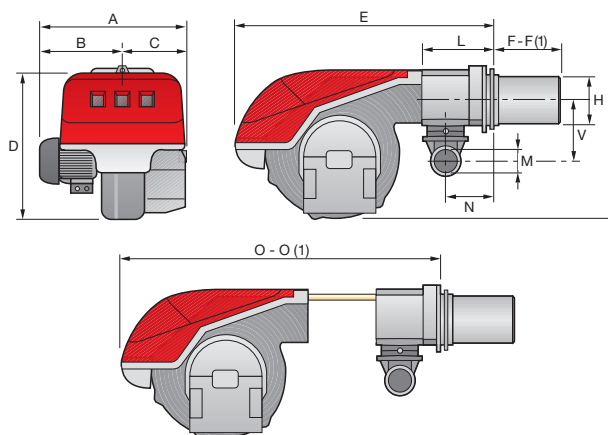

MODEL	A	B	C	D	E	F - F(1)	H	I	L	M	N	O - O(1)	V
▶ RS 64/E MZ	533	300	-	490	640	250 - 385	179	352	222	2"	134	810 - -	221
▶ RS 70/E	527	312	215	555	840	250 - 385	179	430	214	2"	134	1161 - 1296	221
▶ RS 100/E	527	312	215	555	840	250 - 385	179	430	214	2"	134	1161 - 1296	221
▶ RS 130/E	553	338	215	555	840	280 - 415	189	430	214	2"	134	1161 - 1296	221
▶ RS 190/E	675	370	305	555	856	372 - 530	222	436	230	2"	150	1328 - -	264
▶ RS 250/E-EV MZ	732	427	305	555	872	370 - 520	222	436	230	2"	150	1322 - 1467	264

(1) dimension with extended head

Modulating Gas Burners

RS/E-EV MZ SERIES

Overall dimensions (mm)

BURNER - BOILER MOUNTING FLANGE

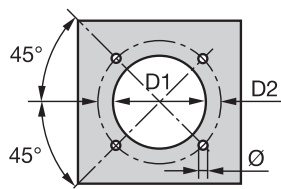

MODEL	D1	D2	Ø
▶ RS 34/E MZ	160	224	M8
▶ RS 44/E MZ	160	224	M8
▶ RS 50/E MZ	160	224	M8
▶ RS 64/E MZ	185	275-325	M12
▶ RS 70/E	185	275-325	M12
▶ RS 100/E	185	275-325	M12
▶ RS 130/E	195	275-325	M12
▶ RS 190/E	230	325-368	M16
▶ RS 250/E-EV MZ	230	325-368	M16

PACKAGING

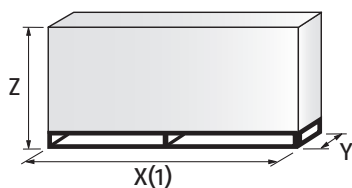

MODEL	X (1)	Y	Z	kg
▶ RS 34/E MZ	1000	485	500	39
▶ RS 44/E MZ	1000	485	500	40
▶ RS 50/E MZ	1200	502	630	48
▶ RS 64/E MZ	1200	580	630	50
▶ RS 70/E	1405	700	660	78
▶ RS 100/E	1405	700	660	81
▶ RS 130/E	1405	700	660	84
▶ RS 190/E	1405	1000	660	89
▶ RS 250/E-EV MZ	1405-1420	1000	660	125

(1) dimension with standard and extended head

RS/E-EV MZ SERIES

Specification

DESIGNATION OF SERIES

Series: R

Fuel: S Natural Gas
 L Light oil
 LS Light oil/Natural Gas
 N Heavy oil

Size:

Setting: /1 Single stage
 /B Two stage
 /M Modulating-Mechanical cam
 /E Electronic cam
 /P Proportioning air/gas valve
 /EV Electronic cam predisposed for variable speed (with inverter)
 /EVi Electronic cam with integrated inverter

Emission: ... or C01 Class 1 EN676
 MZ Class 2 EN676
 BLU Class 3 EN676
 MX Class 3 EN676

Head length: TC standard head
 TL extended head

Flame control system: FS1 Standard/Intermittent (at least 1 stop every 24 h)
 FS2 Continuous (1 stop every 72 h)

Electrical supply to the system:

1/230/50	1/230V/50Hz
3/230/50	3/230V/50Hz
3/400/50	3N/400V/50Hz
3/230-400/50	3/230V/50Hz - 3N/400V/50Hz
3/220/60	3/220V/60Hz
3/380/60	3N/380V/60Hz
3/220-380/60	3/220/60Hz - 3N/380V/60Hz

Auxiliary voltage: 230/50-60	230V/50-60H
110/50-60	110V/50-60Hz

R S 50 /E MZ TC FS1 3/230-400/50 230/50-60

BASIC DESIGNATION

EXTENDED DESIGNATION

Specification

STATE OF SUPPLY

RS 34/E MZ – 44/E MZ models

Monoblock forced draught Low NOx gas burner with two stage progressive or modulating operation, with a specific kit, fully automatic, made up of:

- Microprocessor-based Digital Burner Management System (Electronic Cam)
- Display Interface operating unit to adjust the system
- Air suction circuit **with sound proofing material**
- High performance fan with straight blades
- Air damper for air flow setting and butterfly valve for regulating fuel output controlled by independent stepper motor actuators
- Starting motor at 2800 rpm, single-phase/220-230V/50-60Hz or three-phase/380-400V/50-60Hz
- Low emission combustion head, that can be set on the basis of required output, fitted with:
 - stainless steel end cone, resistant to corrosion and high temperatures
 - ignition electrodes
 - ionisation probe
 - gas distributor
 - flame stability disk
- Exclusive patented HCS (Housing Cooling System) with high thermal insulation and air circulation with continuous air volume refresh for an active cooling system and avoid heat transfer to the electrical component housing
- Minimum air pressure switch stops the burner in case of insufficient air quantity at the combustion head
- Plugs and sockets for electrical connection, accessible from the external of the cover
- Burner on/off selection switch
- Flame inspection window
- Slide bars for easier installation and maintenance
- Protection filter against radio interference
- IP X0D (IP 40) electric protection level.

Standard equipment:

- 1 gas train flange
- 1 flange gasket
- 4 screws for fixing the flange
- 1 thermal screen
- 4 screws for fixing the burner flange to the boiler
- 3 plugs for electrical connection (RS 34-44/E MZ single-phase)
- 4 plugs for electrical connection (RS 44/E MZ three-phase)
- Instruction handbook for installation, use and maintenance
- Spare parts catalogue.

RS/E-EV MZ SERIES

Specification

STATE OF SUPPLY

RS 50/E MZ – 64/E MZ – 70/E – 100/E – 130/E – 190/E – 250/E-EV MZ models

Monoblock forced draught Low NO_x gas burner with two stage progressive or modulating operation, with a specific kit, fully automatic, made up of:

- Microprocessor-based Digital Burner Management System (Electronic Cam)
- Display Interface operating unit to adjust the system
- Air suction circuit lined with sound-proofing material
- Fan with reverse curve blades (straight blades on the RS 64/E MZ – 190/E – 250/E-EV MZ models) high performance with low sound emissions
- Air damper for air flow setting and butterfly valve for regulating fuel output controlled by independent stepper motor actuators
- Starting motor at 2800 rpm, three-phase 400V with neutral, 50Hz
- Low emission combustion head, that can be set on the basis of required output, fitted with:
 - stainless steel end cone, resistant to corrosion and high temperatures
 - ignition electrodes
 - ionisation probe
 - gas distributor
 - flame stability disk
- Maximum gas pressure switch to stop the burner in the case of excess pressure on the fuel supply line
- Minimum air pressure switch stops the burner in case of insufficient air quantity at the combustion head
- Burner on/off selection switch
- Flame inspection window
- Slide bars for easier installation and maintenance
- Protection filter against radio interference
- IP 44 electric protection level.

Standard equipment:

- 1 gas train flange
- 1 flange gasket
- 4 screws for fixing the flange
- 1 thermal screen
- 4 screws for fixing the burner flange to the boiler
- Wiring loom fittings for the electrical connection
- 2 slide bar extensions (for extended head models and RS 190/E – 250/E-EV MZ models)
- Pressure switch for valve proofing system (RS 130/E – 190/E – 250/E-EV MZ models)
- Instruction handbook for installation, use and maintenance
- Spare parts catalogue.

Modulating Gas Burners

RS/E-EV MZ SERIES

Available models

Burners

CODE	MODEL					HEAT OUTPUT NATURAL GAS		TOTAL ELECTRICAL POWER (kW)	CERTIFICATION	NOTE
						(kW)	(Nm ³ /h)			
3789410	RS 34/E MZ	TC	FS1	1/220-230/50-60	220-230/50-60	44/130÷390	4,5/13÷39	0,6	CE 0085BS0378	(1)(3)
3789411	RS 34/E MZ	TL	FS1	1/220-230/50-60	220-230/50-60	44/130÷390	4,5/13÷39	0,6	CE 0085BS0378	(1)(3)
3789510	RS 44/E MZ	TC	FS1	1/220-230/50-60	220-230/50-60	80/200÷550	8/20÷55	0,7	CE 0085BS0378	(1)(3)
3789511	RS 44/E MZ	TL	FS1	1/220-230/50-60	220-230/50-60	80/200÷550	8/20÷55	0,7	CE 0085BS0378	(1)(3)
3789540	RS 44/E MZ	TC	FS1	3/220-400/50-60	220-230/50-60	80/200÷550	8/20÷55	0,75	CE 0085BS0378	(1)(3)
3789541	RS 44/E MZ	TL	FS1	3/220-400/50-60	220-230/50-60	80/200÷550	8/20÷55	0,75	CE 0085BS0378	(1)(3)
3781632	RS 50/E MZ	TC	FS1	3/230-400/50	230/50-60	85/290-580	8,5/29-58	0,75	CE 0085AQ0709	(1)(3)
3781633	RS 50/E MZ	TL	FS1	3/230-400/50	230/50-60	85/290-580	8,5/29-58	0,75	CE 0085AQ0709	(1)(3)
3789910	RS 64/E MZ	TC	FS1	3/230-400/50	230/50-60	150/400÷850	15/40÷85	1,2	-	(1)(3)
3789911	RS 64/E MZ	TL	FS1	3/230-400/50	230/50-60	150/400÷850	15/40÷85	1,2	-	(1)(3)
3787032	RS 70/E	TC	FS1	3/230-400/50	230/50-60	135/465-814	13,5/46,5-81	1,6	CE 0085AQ0708	(2)(3)
3787033	RS 70/E	TL	FS1	3/230-400/50	230/50-60	135/465-814	13,5/46,5-81	1,6	CE 0085AQ0708	(2)(3)
3787232	RS 100/E	TC	FS1	3/230-400/50	230/50-60	150/698-1163	15/70-116	2,0	CE 0085AQ0708	(2)(3)
3787233	RS 100/E	TL	FS1	3/230-400/50	230/50-60	150/698-1163	15/70-116	2,0	CE 0085AQ0708	(2)(3)
3787432	RS 130/E	TC	FS1	3/230-400/50	230/50-60	160/930-1512	16/93-151	2,8	CE 0085AQ0708	(2)(4)
3787433	RS 130/E	TL	FS1	3/230-400/50	230/50-60	160/930-1512	16/93-151	2,8	CE 0085AQ0708	(2)(4)
3787632	RS 190/E	TC	FS1	3/400/50	230/50-60	470/1279-2290	47/128-229	5,3	-	(2)(4)
20052617	RS 190/E	TL	FS1	3/400/50	230/50-60	470/1279-2290	47/128-229	5,3	-	(2)(4)
20142732	RS 190/EV	TC	FS1	3/230-400/50	230/50-60	470/1279-2290	47/128-229	5,3	-	(2)(4)
3789210	RS 250/E MZ	TC	FS1	3/400/50	230/50-60	600/1250÷2650	60/125÷265	6,5	CE 0085BT0061	(2)(4)
3789211	RS 250/E MZ	TL	FS1	3/400/50	230/50-60	600/1250÷2650	60/125÷265	6,5	CE 0085BT0061	(2)(4)
20010541	RS 250/E MZ	TC	FS1	3/380/60	220/60	600/1250÷2650	60/125÷265	6,5	-	(2)(4)
20014098	RS 250/EV MZ	TC	FS1	3/400/50	230/50-60	600/1250÷2650	60/125÷265	6,5	CE 0085BT0061	(2)(4)

Natural Gas, net calorific value: 10 kWh/Nm³ - Density at 20°C: 0,71 kg/Nm³

The burners of RS/E MZ series are in according to 2016/426/EU - 2014/30/EU - 2014/35/EU - 2006/42 CE Directive and EN 676 Norm.

(1) With plug and socket.

(2) With terminal board.

(3) Seal control function is included on Burner Digital Management System; it is necessary to add the PVP kit on the gas train as Accessory (see Gas Train Accessories paragraph).

(4) Seal control function is included on Burner Digital Management System; it is necessary to add the PVP kit (included as burner standard equipment) on the gas train.

Available models

Gas Trains

CODE	GAS TRAIN		ADAPTER CODE								
	MODEL	Ø	RS 34	RS 44-50	RS 64	RS 70	RS 100	RS 130	RS 150	RS 190	RS 250
3970599*	MB 407/1 - RT 52	Rp 3/4"	3000824		●	●	●	●	●	●	●
3970258*	MB 410/1 - RT 52	Rp 1" 1/4	3010124		3000843		●	●	●	●	●
3970600*	MB 410/1 - RT 52	Rp 3/4"	3000824		3000824 + 3000843		●	●	●	●	●
3970256*	MB 412/1 - RT 52	Rp 1" 1/2	□	□	3000843						
3970250*	MB 415/1 - RT 52	Rp 1" 1/2	□	□	3000843						
3970257*	MB 420/1 - RT 52	Rp 2"	3000822		□	□	□	□	□	□	□
3970221*	MBC 1200/1 - RSM 60	Rp 2"	3000822		□	□	□	□	□	□	□
3970222*	MBC 1900/1 - FSM 40	DN 65	●	●	3000825						
3970223*	MBC 3100/1 - FSM 40	DN 80	●	●	3000826						
3970224	MBC 5000/1 - FSM 80	DN 100	●	●	●	●	●	●	●	●	3010370 + 3000826
3970145*	CB 512/1 - RSM 30	Rp 1" 1/2	-	-	3000843						
3970146*	CB 520/1 - RSM 30	Rp 2"	3000822		□	□	□	□	□	□	□
20044659*	CB 525/1 - RSM 30	Rp 2"	3000822		□	□	□	□	□	□	□
3970147*	CB 5065/1 - FSM 30	DN 65	●		3000825						
3970148*	CB 5080/1 - FSM 30	DN 80	●	●	3000826						
3970149*	CB 50100/1 - FSM 30	DN 100	●	●	3010370 + 3000826						
20015871*	CB 50125/1 - FSM 30	DN 125	●	●	●	●	●	3010224 + 3000826			

Please see designation of Gas Train Series in the page before the Catalogue index.

* gas train are 230V/50Hz - 220V/60Hz electrical supply.

The valve seal control device is compulsory (conforming to EN 676) on gas trains to burners with a maximum output over 1200 kW.

The seal control function is managed by REC control box, by installation on gas train of a pressure switch (please see Gas train accessories paragraph); it is included as standard equipment on RS 130/E-190/E-250/E-EV MZ models.

The seal control function is managed by LMV control box, by installation on gas train of pressure switch supplied, as standard equipment, with the burner.

To select the gas train please refer to the technical data leaflet and/or instruction manual.

● Not available.

□ Additional adapter not necessary, the gas train may be connected directly to the burner.

Modulating Gas Burners

RS/E-EV MZ SERIES

Burner accessories

Extended heads

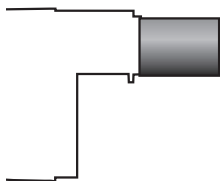

“Standard head” burners can be transformed into “extended head” versions, by using the special kit. The KITS available for the various burners, giving the original and the extended lengths, are listed below.

BURNER	'STANDARD HEAD' LENGTH (mm)	'EXTENDED HEAD' LENGTH (mm)	KIT CODE
▶ RS 34/E MZ	216	351	3010428
▶ RS 44/E MZ	216	351	3010429
▶ RS 50/E MZ	216	351	20008182
▶ RS 64/E MZ	250	385	3010427
▶ RS 70/E	250	385	3010117
▶ RS 100/E	250	385	3010118
▶ RS 130/E	280	415	3010119
▶ RS 190/E	372	530	3010443
▶ RS 250/E-EV MZ	370	520	3010412

Spacer kit

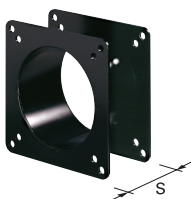

If burner head penetration into the combustion chamber needs reducing, varying thickness spacers are available, as given in the following table:

BURNER	SPACER THICKNESS S (mm)	KIT CODE
▶ RS 34-44-50/E MZ	110	3010095
▶ RS 64/E MZ - RS 70-100-130/E	135	3010129
▶ RS 190/E - RS 250/E-EV MZ	102	3000722

Continuous ventilation kit



If the burner requires continuous ventilation in the stages without flame, a special kit is available as given in the following table:

BURNER	KIT CODE
▶ RS 34-44/E MZ	3010449
▶ RS 50-64/E MZ - RS 70-100-130-190/E - RS 250/E-EV MZ	3010094

Sound proofing box

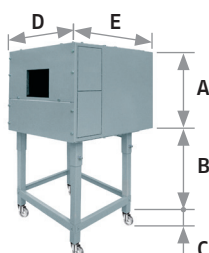

If noise emission needs reducing even further, sound-proofing boxes are available. When a lower “B” dimension is required, it is available the Box Support Kit code 20065135 which allows to reduce it at the fixed dimension of 55 mm. The sound-proofing boxes are not suitable for outdoor use.

BURNER	BOX TYPE	A (mm)	B (mm) min-max	C (mm)	D (mm)	E (mm)	[dB(A)] (*)	BOX CODE
▶ RS 34-44-50-64/E MZ	C1/3	650	372 - 980	110	690	770	10	3010403
▶ RS 70-100-130-190/E ▶ RS 250/E-EV MZ	C4/5	850	160 - 980	110	980	930	10	3010404

(*) Average noise reduction according to EN 15036-1 standard

Burner accessories

Accessories for modulating operation



To obtain modulating operation, the RS/E series of burners requires a regulator with three point outlet controls. On RS 34/E MZ - 44/E MZ - 250/E MZ the regulator is connected to the burner electrical wiring by plug-in system in order to make the connection easier and faster.

The relative temperature or pressure probes fitted to the regulator must be chosen on the basis of the application.

The following table lists the accessories for modulating operation with their application range.

For remote setpoint use RWF 55.

BURNER	REGULATOR TYPE	KIT CODE
▶ RS 34-44-64/E MZ	RWF 50.2	20083339
	RWF 55.5	20098541
▶ RS 50/E MZ - RS 70-100-130-190/E RS 250/E-EV MZ	RWF 50.2	20099869
	RWF 55.5	20099905



BURNER	PROBE TYPE	RANGE (°C) (bar)	KIT CODE
▶ All models	Temperature PT 100	-100 ÷ 500°C	3010110
	Pressure 4 ÷ 20 mA	0 ÷ 2,5 bar	3010213
	Pressure 4 ÷ 20 mA	0 ÷ 16 bar	3010214
	Pressure 4 ÷ 20 mA	0 ÷ 25 bar	3090873

Connection flange kit

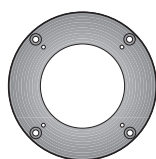

A kit is available for use where the burner opening on the boiler is of excessive diameter.

BURNER	KIT CODE
▶ RS 34-44-50/E MZ	3010138

LPG kit



For burning LPG gas, a special kit is available to be fitted to the combustion head on the burner, as given in the following table:

BURNER	KIT CODE FOR 'STANDARD HEAD' (*)	KIT CODE FOR 'EXTENDED HEAD' (*)
▶ RS 34/E MZ	3010423	3010423
▶ RS 44/E MZ	3010424	3010424
▶ RS 50/E MZ	20008173	20008173
▶ RS 64/E MZ	3010434	3010435
▶ RS 70/E	20008175	20008176
▶ RS 100/E	20008177	20008178
▶ RS 130/E	20008179	20008180
▶ RS 190/E	3010166	3010166
▶ RS 250/E-EV MZ	3010411	3010411

(*) CE approval on field is required

Modulating Gas Burners

RS/E-EV MZ SERIES

Burner accessories

Town gas kit

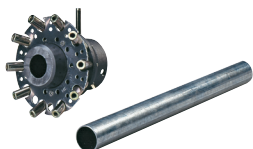

For burning Town gas, a special kit is available:

BURNER	KIT CODE FOR 'STANDARD HEAD' (*)	KIT CODE FOR 'EXTENDED HEAD' (*)
▶ RS 34/E MZ	3010502	3010502
▶ RS 44/E MZ	3010503	3010503
▶ RS 50/E MZ	3010285	3010285
▶ RS 70/E	3010286	3010286
▶ RS 100/E	3010287	3010287
▶ RS 130/E	3010288	3010288
▶ RS 190/E	3010297	3010297

(*) Without CE certification

Ground fault interrupter kit



A "Ground fault interrupter kit" is available as a safety device for electrical system fault.

BURNER	KIT CODE
▶ RS 34-44/E MZ	3010448
▶ RS 50-64/E MZ	20098335
▶ RS 70-100-130-190/E - RS 250/E-EV MZ	20098337

Gas max pressure switch

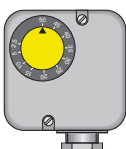

If necessary a Gas max pressure Switch kit is available and connectable to the burner electrical wiring through Plugs & Sockets system.

BURNER	KIT CODE
▶ RS 34-44/E MZ	3010418

Volt free contact kit



A volt free contact kit is available for installation onto the burner. It can be used for a remote interface between burner operating signals. Every burner can be equipped with a single kit for a remote check of the flame presence signal and the burner lock-out indication.

BURNER	KIT CODE
▶ RS 34-44/E MZ	3010419

DN80 gas flange kit

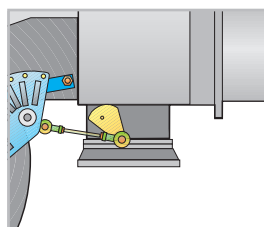

To modify the standard 2" burner gas input connection in to DN80 connection, a specific gas flange is available.

BURNER	KIT CODE
▶ RS 64/E MZ - RS 70-100-130-190/E - RS 250/E EV MZ	3010439

Burner accessories

Variable Speed Drive (VSD) for RS/EV series only



The motor speed variation for the RS/EV MZ burners series is obtained thanks to a frequency converter: variable speed drive (VSD), provided with a programming panel with start-up assistant. It always must be ordered with RS/EV series.

BURNER	MAX POWER (kW)	KIT CODE
▶ RS 250/EV MZ	5,5	20163071

PC Interface kit



To connect the control box to a personal computer for the transmission of operation, fault signals and detailed service information, an interface adapter with PC software are available.

BURNER	KIT CODE
▶ RS 34-44-50-64/E MZ - RS 70-100-130-190/E - RS 250/E-EV MZ	3010436

OCI412 interface kit



Interface kit between the REC27.100A2 and a Modbus system, such as a building automation and control system (BACS). The Modbus interface is based on the RS-485 standard.

BURNER	KIT CODE
▶ RS 34-44-50-64/E MZ - RS 70-100-130-190/E - RS 250/E-EV MZ	3010437

Head kit for “reverse flame chamber”



In certain cases, the use of the burner on reverse flame boilers can be improved by using an additional cylinder.

BURNER	STANDARD HEAD LENGTH WITH CYLINDER (mm)	EXTENDED HEAD LENGTH WITH CYLINDER (mm)	KIT CODE (*)
▶ RS 190/E	493	-	3010241

(*) CE approval on field is required

Vibration reduction kit



The kit allow you to improve flame stability in some applications, where the boiler/flue assembly is liable to resonate.

BURNER	KIT CODE
▶ RS 34/E MZ (Natural Gas)	20098750
▶ RS 34/E MZ (LPG)	20098753
▶ RS 44/E MZ (Natural Gas)	20098746







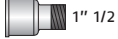

Modulating Gas Burners

RS/E-EV MZ SERIES

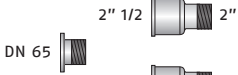
Gas train accessories

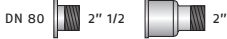
Adapters

In certain cases, an adapter must be fitted between the gas train and the burner, when the diameter of the gas train is different from the set diameter of the burner. Below are given the available adapters; please see on the Gas Train list the correct adapter codes to select.

ADAPTER	LENGTH mm	ADAPTER CODE
 2" 1" 1/2	70	3000822
 3/4" 1" 1/2	31	3000824
 DN 65 2" 1/2 2"	300	3000825
 DN 65 2" 1/2 1" 1/2		
 DN 80 2" 1/2 2"	300	3000826
 1" 1/2 2"	35	3000843
 1" 1/4 1" 1/2	35	3010124
 1" 1/4 2"	35	3010126

Stabiliser spring



Accessory springs are available to vary the pressure range of the gas train stabilisers. The following table shows these accessories with their application range. Please refer to the technical manual for the correct choice of spring.

GAS TRAIN	SPRING COLOUR	SPRING PRESSURE RANGE mbar	SPRING CODE
▶ MBC 1900/1 - 3100/1 MBC 5000/1	White	4 - 20	3010381
	Red	20 - 40	3010382
	Black	40 - 80	3010383
	Green	80 - 150	3010384
▶ CB 512/1	Red	25 - 55	3010131
	Black	60 - 110	3010157
▶ CB 520/1 - 525/1	Pink	90 - 150	3090486
	Red	25 - 55	3010132
	Black	60 - 110	3010158
▶ CB 5065/1 - 5080/1	Pink	100 - 150	3090487
	Red	25 - 55	3010133
	Black	60 - 110	3010135
	Pink	100 - 150	3090456
	Grey	140 - 200	3090992

PVP (Pressure Valve Proving) kit *

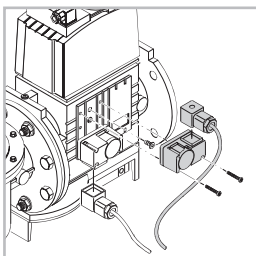

The seal control function is included on Burner Digital Management System, it is only necessary to add the PVP kit on the gas train. The PVP is included as standard equipment on RS 130/E-250/E-EV MZ and RS 190/E models.

BURNER	KIT CODE
▶ MB - MBC - CB type	3010344

* not necessary for the RS 130/E-250/E MZ and RS 190/E models where is included as a standard.

RS 310-410-510-610/M MZ SERIES

The RS 310-410-510-610/M MZ burners series covers a firing range from 1300 to 6300 kW, and it has been designed for use in low or medium temperature hot water boilers, hot air or steam boilers, diathermic oil boilers.

Operation can be "two stage progressive" or, alternatively, "modulating" with the installation of a PID logic regulator or by external 4-20 mA/0-10 V signal.

The mechanical cam device of regulation allows to catch up a high modulation ratio on all firing rates range. The burners can, therefore, supply with precision the demanded power, guaranteeing a high efficiency system level and the stability setting, obtaining fuel consumption and operating costs reduction.

FS1 and FS2 versions are available for intermittent and continuous operation applications.

The exclusive design ensures reduced dimensions, simple use and maintenance.

A wide range of accessories guarantees elevated working flexibility.



RS 310/M MZ	600/1300 ÷ 3900	kW
RS 410/M MZ	800/2000 ÷ 4900	kW
RS 510/M MZ	800/2200 ÷ 5520	kW
RS 610/M MZ	820/2400 ÷ 6300	kW

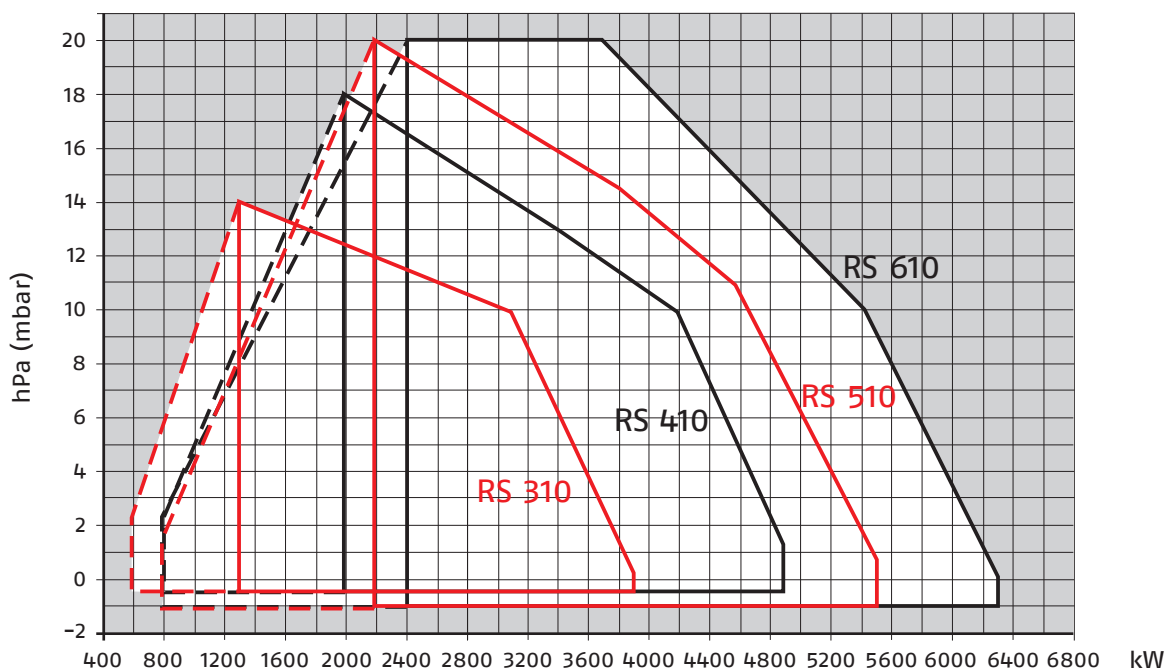

Modulating Gas Burners

RS 310-410-510-610/M MZ SERIES

Overall dimensions (mm)

BURNERS

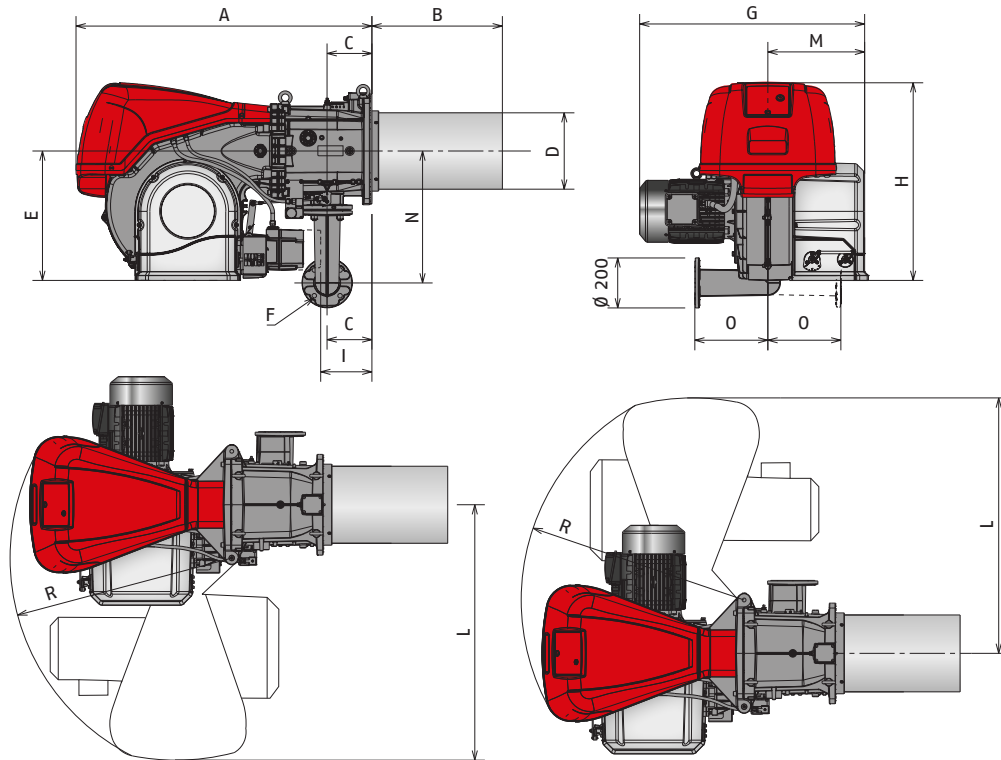

Model	A	B	C	D	E	F	G	H	I*	L	M	N	O	P	R
▶ RS 310/M MZ	1178	519	178	306	520	DN65	890	790	177	1015	400	528	290	177	890
▶ RS 410/M MZ	1178	519	178	306	520	DN65	908	790	177	1015	400	528	290	177	890
▶ RS 510/M MZ	1178	519	178	306	520	DN65	908	790	177	1015	400	528	290	177	890
▶ RS 610/M MZ	1178	519	178	330	520	DN65	980	790	177	1015	400	528	290	177	890

* Maximum position for the extraction of the servomotor cover in mechanical cam models.

BURNER - BOILER MOUNTING FLANGE

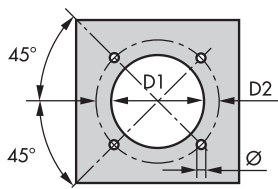

Model	D1	D2	Ø
▶ RS 310/M MZ	335	452	M18
▶ RS 410/M MZ	335	452	M18
▶ RS 510/M MZ	335	452	M18
▶ RS 610/M MZ	350	452	M18

PACKAGING

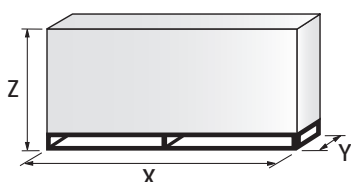

Model	X	Y	Z	kg
▶ RS 310/M MZ	2040	1180	1125	250
▶ RS 410/M MZ	2040	1180	1125	250
▶ RS 510/M MZ	2040	1180	1125	250
▶ RS 610/M MZ	2040	1180	1125	280

RS 310-410-510-610/M MZ SERIES

Specification

DESIGNATION OF SERIES

A specific index guides your choice of burner from the various models available in the RS/M MZ series. Below is a clear and detailed specification description of the product.

Series: R									
Fuel: S Natural Gas									
L Light oil									
LS Light oil/Natural Gas									
N Heavy oil									
Size:									
Setting: /1 Single stage									
/B Two stage									
/M Modulating-Mechanical cam									
/E Electronic cam									
/P Proportioning air/gas valve									
/EV Electronic cam predisposed for variable speed (with inverter)									
/EVi Electronic cam with integrated inverter									
Emission: ... or C01					Class 1 EN676				
MZ					Class 2 EN676				
BLU					Class 3 EN676				
MX					Class 3 EN676				
Head length: TC standard head									
TL extended head									
Flame control system: FS1 Standard/Intermittent (at least 1 stop every 24 h)									
FS2 Continuous (1 stop every 72 h)									
Electrical supply to the system:									
1/230/50					1/230V/50Hz				
3/230/50					3/230V/50Hz				
3/400/50					3N/400V/50Hz				
3/230-400/50					3/230V/50Hz - 3N/400V/50Hz				
3/220/60					3/220V/60Hz				
3/380/60					3N/380V/60Hz				
3/220-380/60					3/220/60Hz - 3N/380V/60Hz				
Auxiliary voltage: 230/50-60 230V/50-60H									
110/50-60 110V/50-60Hz									
R	S	510	/M	MZ	TC	FS1	3/230-400/50	230/50-60	
BASIC DESIGNATION									
EXTENDED DESIGNATION									

Specification

STATE OF SUPPLY

Monoblock forced draught gas burners with modulating operation, fully automatic, made up of:

- High performance fan with low sound emissions, forward curve blades.
- Air suction circuit lined with sound-proofing material
- Air damper for air setting controlled by a high precision servomotor
- Air pressure switch
- Fan starting motor at 2900 rpm, three-phase 230/400 - 400/690 V with neutral, 50 Hz
- Combustion head, that can be set on the basis of required output, fitted with:
 - stainless steel end cone, resistant to corrosion and high temperatures
 - ignition electrodes; ionisation sensor for flame detection
 - flame stability disk
- Maximum gas pressure switch, with pressure test point, for halting the burner in the case of over pressure on the fuel supply line
- Burner safety control box for controlling the system safety: RMG/M and RFG0 for FS1 intermittent operation and LGK for FS2 continuous operation for RS 310-410-510-610/M models;
- Star/delta starter for the fan motor (Direct starter fan motor for RS 310-410 models)
- Main electrical supply terminal board
- Burner on/off switch
- Manual or automatic output increase/decrease switch
- Contacts motor and thermal relay with release button
- Burner failure led signal and lighted release button
- Burner opening hinge
- Lifting rings
- IP 54 electric protection level

Standard equipment:

Gasket for gas train adaptor

Adaptor for gas train

Screws for fixing the gas train adaptor: M 16 x 70

Thermal insulation screen

M 18 x 60 screws to secure the burner flange to the boiler

Cable grommets kit for optional electrical wiring input

M16 x 6 studs for fixing the gas elbow to the pipe coupling

M16 nuts to fix the gas elbow to the pipe coupling

Instruction handbook for installation, use and maintenance

Spare parts catalogue

Gas train

Fuel supply line, in the MULTIBLOC configuration (for a diameter of 1-1/2" and 2") or COMPOSED configuration (from a diameter of DN 65 until a diameter of DN 125), fitted with:

- Filter
- Stabiliser
- Minimum gas pressure switch
- Safety valve
- One stage working valve with ignition gas output regulator.

RS 310-410-510-610/M MZ SERIES

Specification

Conforming to:

- 2014/30/EU directive (electromagnetic compatibility)
- 2014/35/EU directive (low voltage)
- 2016/426/EU gas regulation (GAR)
- 2006/42 CE directive (machine)
- EN 676 (gas burners).

Available accessories to be ordered separately:

- Power controller
- Probe
- Analog control signal converter
- Potentiometer
- Continuous ventilation kit
- PC interface kit
- Sound proofing box
- Spacer kit
- Adapters
- Seal Control kit
- Stabiliser spring.

Modulating Gas Burners

RS 310-410-510-610/M MZ SERIES

Available models

Burners

CODE	MODEL				HEAT OUTPUT NATURAL GAS		TOTAL ELECTRICAL POWER (kW)	CERTIFICATION	NOTE
					(kW)	(Nm ³ /h)			
20061373	RS 310/M MZ	TC	FS1	3/400/50	600/1300-3900	60/130-390	8,8	CE-0085CP0166	(1) (4)
20068343	RS 310/M MZ	TC	FS1	3/230/50	600/1300-3900	60/130-390	9,1	CE-0085CP0166	(1)
20068351	RS 310/M MZ	TC	FS1	3/400/50	600/1300-3900	60/130-390	9,1	CE-0085CP0166	(1)
20152665	RS 310/M MZ	TC	FS1/FS2	3/400/50	600/1300-3900	60/130-390	9,1	CE-0085CP0166	(2)(4)(3)
20152658	RS 310/M MZ	TC	FS1/FS2	3/230/50	600/1300-3900	60/130-390	9,1	CE-0085CP0166	(2)(3)
20152661	RS 310/M MZ	TC	FS1/FS2	3/400/50	600/1300-3900	60/130-390	9,1	CE-0085CP0166	(2)(3)
20067141	RS 410/M MZ	TC	FS1	3/400/50	800/2000-4900	80/200-490	10,6	CE-0085CP0166	(1)(4)
20068356	RS 410/M MZ	TC	FS1	3/230/50	800/2000-4900	80/200-490	10,8	CE-0085CP0166	(1)
20068361	RS 410/M MZ	TC	FS1	3/400/50	800/2000-4900	80/200-490	10,8	CE-0085CP0166	(1)
20152669	RS 410/M MZ	TC	FS1/FS2	3/400/50	800/2000-4900	80/200-490	10,8	CE-0085CP0166	(2)(4)(3)
20152662	RS 410/M MZ	TC	FS1/FS2	3/230/50	800/2000-4900	80/200-490	10,8	CE-0085CP0166	(2)(3)
20152664	RS 410/M MZ	TC	FS1/FS2	3/400/50	800/2000-4900	80/200-490	10,8	CE-0085CP0166	(2)(3)
20068027	RS 510/M MZ	TC	FS1	3/400/50	800/2200-5520	80.2/220-552	14	CE-0085CP0166	(1)(4)
20152671	RS 510/M MZ	TC	FS1/FS2	3/400/50	800/2200-5520	80.2/220-552	14	CE-0085CP0166	(2)(4)
20066706	RS 610/M MZ	TC	FS1	3/400/50	820/2400-6300	82/240-630	16,9	CE-0085CP0166	(1)(4)
20152672	RS 610/M MZ	TC	FS1/FS2	3/400/50	820/2400-6300	82/240-630	16,9	CE-0085CP0166	(2)(4)(3)

Natural gas, net calorific value: 10 kWh/Nm³ - Density: 0,71 kg/Nm³

The burners of RS/M MZ series are in according to 2016/426/EU - 2014/30/EU - 2014/35/EU - 2006/42 CE Directives.

(1) with RMG control box

(2) with RFGO control box

(3) FS2 operation is allowed with ionization probe only, no other flame sensors can be used

(4) Star delta starter

(5) LFL control box

Due to the improvement applied on the technical specification of some products, some burner codes will change during year 2019. The table below summarizes the correspondence between the previous and the new code.

MODEL				NEW CODE		OLD CODE	
RS 310/M MZ	TC	FS1/FS2	3/230/50	20152658	(2)(3)	20074137	(5)
RS 310/M MZ	TC	FS1/FS2	3/400/50	20152661	(2)(3)	20074138	(5)
RS 310/M MZ	TC	FS1/FS2	3/400/50	20152665	(2)(3)	20074141	(5)
RS 410/M MZ	TC	FS1/FS2	3/230/50	20152662	(2)(3)	20074139	(5)
RS 410/M MZ	TC	FS1/FS2	3/400/50	20152664	(2)(3)	20074140	(5)
RS 410/M MZ	TC	FS1/FS2	3/400/50	20152669	(2)(3)	20074142	(5)
RS 510/M MZ	TC	FS1/FS2	3/400/50	20152671	(2)(3)	20074143	(5)
RS 610/M MZ	TC	FS1/FS2	3/400/50	20152672	(2)(3)	20074144	(5)

RS 310-410-510-610/M MZ SERIES

Available models

Gas Trains

CODE	GAS TRAIN			VPS Code	ADAPTER CODE			
	MODEL	∅	C.T.		RS 310	RS 410	RS 510	RS 610
3970180*	MB 415/1 - RT 30	Rp 1" 1/2	-	3010123	3000826 + 20064220	●	●	●
3970198**	MB 415/1 CT RT 30	Rp 1" 1/2	◆	-		●	●	●
3970250*	MB 415/1 - RT 52	Rp 1" 1/2	-	3010123		●	●	●
3970253**	MB 415/1 CT RT 52	Rp 1" 1/2	◆	-		●	●	●
3970232*	MB 415/1 - RSM 30	Rp 1" 1/2	-	3010123	3000826 + 20042324	●	●	●
3970181*	MB 420/1 - RT 30	Rp 2"	-	3010123		●	●	●
3970182**	MB 420/1 CT RT 30	Rp 2"	◆	-		●	●	●
3970257*	MB 420/1 - RT 52	Rp 2"	-	3010123		●	●	●
3970252**	MB 420/1 CT RT 52	Rp 2"	◆	-		●	●	●
3970233*	MB 420/1 - RSM 30	Rp 2"	-	3010123		●	●	●
3970234**	MB 420/1 CT RSM 30	Rp 2"	◆	-		●	●	●
3970221*	MBC 1200/1 - RSM 60	Rp 2"	-	3010123		3000826 + 20042324		
3970225**	MBC 1200/1 CT RSM 60	Rp 2"	◆	-	3010221			
3970222*	MBC 1900/1 - FSM 40	DN 65	-	3010123	3010222			
3970226**	MBC 1900/1 CT FSM 40	DN 65	◆	-	3010222			
3970223*	MBC 3100/1 - FSM 40	DN 80	-	3010123	3010222 - 3010370			
3970227**	MBC 3100/1 CT FSM 40	DN 80	◆	-	3010222 - 3010370			
3970224*	MBC 5000/1 - FSM 80	DN 100	-	3010123	3010222 - 3010370			
3970228**	MBC 5000/1 CT FSM 80	DN 100	◆	-	3010222 - 3010370			
3970145*	CB 512/1 - RSM 30	Rp 1" 1/2	-	3010123	3000826 + 20064220	●	●	
20045589**	CB 512/1 CT RSM 30	Rp 1" 1/2	◆	-		●	●	
3970146*	CB 520/1 - RSM 30	Rp 2"	-	3010123	3000826 + 20042324	●	●	
3970160**	CB 520/1 CT RSM 30	Rp 2"	◆	-		●	●	
20044659*	CB 525/1 - RSM 30	Rp 2"	-	3010123	3000826 + 20042324			
20044660**	CB 525/1 CT RSM 30	Rp 2"	◆	-	3000826 + 20042324			
3970147*	CB 5065/1 - FSM 30	DN 65	-	3010123	3010221			
3970161**	CB 5065/1 CT FSM 30	DN 65	◆	-	3010221			
3970148*	CB 5080/1 - FSM 30	DN 80	-	3010123	3010222			
3970162**	CB 5080/1 CT FSM 30	DN 80	◆	-	3010222			
3970149*	CB 50100/1 - FSM 30	DN 100	-	3010123	3010223 - 3010370			
3970163**	CB 50100/1 CT FSM 30	DN 100	◆	-	3010223 - 3010370			
20015871*	CB 50125/1 - FSM 30	DN 125	-	3010123	3010224			
3970196**	CB 50125/1 CT FSM 30	DN 125	◆	-	3010224			

Please see designation of Gas Train Series in the page before the Catalogue index.

* 230V/50Hz - 220V/60Hz electrical supply.

** 230V/50Hz electrical supply.

The valve seal control device is compulsory (conforming to EN 676) on gas trains to burners with a maximum output over 1200 kW.

To select the gas train please refer to the technical data leaflet and/or instruction manual.

C.T. Gas valve leak detection control device:

- gas train not equipped with leak detection control device; this device can be ordered separately - see VPS column - and installed later.

◆ gas train equipped with leak detection control device.

VPS Valve leak detection control device. Supplied separately from the gas train (please see Gas train accessories paragraph for both 50 Hz and 60 Hz codes).

● Not available.

□ Additional adapter not necessary, the gas train may be connected directly to the burner.

Modulating Gas Burners

RS 310-410-510-610/M MZ SERIES

Burner accessories

Accessories for modulating operation

POWER CONTROLLER



To obtain modulating operation, the RS/M BLU series of burners requires a regulator with three point outlet controls. The following table lists the accessories for modulating operation with their application range. For remote setpoint use RWF 55.

BURNER	TYPE	KIT CODE
► All models	RWF 50.2 - Basic version with 3 position output	20073595
	RWF 55.5 - Complete with RS-485 interface	20074441
	RWF 55.6 - Complete with RS-485/ PROFIBUS interface	20074442

PROBE



The relative temperature or pressure probes fitted to the power controller must be chosen on the basis of the application.

BURNER	TYPE	RANGE (°C) (BAR)	KIT CODE
► All models	Temperature PT 100	-100 ÷ 500°C	3010110
	Pressure 4 ÷ 20 mA	0 ÷ 2,5 bar	3010213
	Pressure 4 ÷ 20 mA	0 ÷ 16 bar	3010214
	Pressure 4 ÷ 20 mA	0 ÷ 25 bar	3090873

ANALOG CONTROL SIGNAL CONVERTER



BURNER	TYPE (INPUT SIGNAL)	KIT CODE
► RS 310-410-510-610/M	0/2 - 10 V (impedance 200 KΩ)	20074479
	0/4 - 20 mA (impedance 250 Ω)	

POTENTIOMETER

BURNER	KIT CODE
► RS 310-410-510-610/M	20074487

Continuous ventilation kit



If the burner requires continuous ventilation in the stages without flame, a special kit is available as given in the following table:

BURNER	KIT CODE
► RS 310-410-510-610/M	20074542

RS 310-410-510-610/M MZ SERIES

Burner accessories

PC interface kit



To connect the RMG control panel to a personal computer for the transmission of operation, fault signals and detailed service information, an interface adapter with PC software are available.

BURNER	KIT CODE
▶ RS 310-410-510-610/M	3002719

Sound proofing box

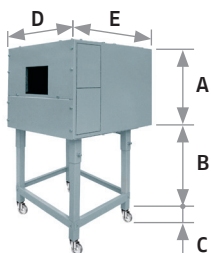

If noise emission needs reducing even further, sound-proofing boxes are available.

When a lower "B" dimension is required, it is available the Box Support Kit code 20065135 which allows to reduce it at the fixed dimension of 55 mm. The sound-proofing boxes are not suitable for outdoor use.

BURNER	BOX TYPE	A (mm)	B (mm) min. - max	C (mm)	D (mm)	E (mm)	[dB(A)] (*)	KIT CODE
▶ RS 310-410/M	C7	1255	160 - 980	110	1140	1345	10	3010376
▶ RS 610/M	C7 PLUS	1255	270 - 1090	110	1240	1345	10	20085111
▶ RS 310-410/M RS510/M	C7	1255	165	110	1140	1345	10	20027778

(*) Average noise reduction according to EN 15036-1 standard

Spacer kit

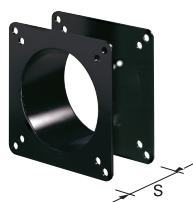

If burner head penetration into the combustion chamber needs reducing, varying thickness spacers are available, as given in the following table:

BURNER	Spacer thickness S (mm)	KIT CODE
▶ All models	180	20008903



Modulating Gas Burners

RS 310-410-510-610/M MZ SERIES

Gas train accessories

Adapters

In certain cases, an adapter must be fitted between the gas train and the burner, when the diameter of the gas train is different from the set diameter of the burner. Below are given the available adapters; please see on the Gas Train list the correct adapter codes to select.

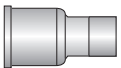
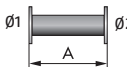
ADAPTER	DIMENSIONS				ADAPTER CODE
	ø1 DN	ø2 DN	A mm	B mm	
1" 1/2  2"	-	-	65	-	20064220
2"  2"	-	-	65	-	20042324
DN 80  2" 1/2  2"	-	-	300	-	3000826
	65	80	400	-	3010221
	80	80	400	-	3010222
	100	80	400	-	3010223
	125	80	320	-	3010224

Seal control kit



To test the valve seals on the gas train, a special "seal control kit" is available. The valve seal control device is compulsory (EN 676) on gas trains to burners with a maximum output over 1200 kW.

The seal control is type VPS 504.

GAS TRAIN	Kit code for 50 Hz operation
▶ MB type	3010123
▶ MCB - CB - DMV type	3010123

RS 310-410-510-610/M MZ SERIES

Stabiliser spring



To vary the pressure range of the gas train stabilisers, accessory springs are available. The following table shows these accessories with their application range. Please refer to the technical manual for the correct choice of spring.

GAS TRAIN	SPRING COLOUR	SPRING Pressure range mbar	SPRING CODE
MBC 1900/1 - 3100/1 MBC 5000/1	White	4 - 20	3010381
	Red	20 - 40	3010382
	Black	40 - 80	3010383
CB 512/1	Green	80 - 150	3010384
	Red	25 - 55	3010131
	Black	60 - 110	3010157
	Pink	90 - 150	3090486
CB 520/1 - 525/1	Red	25 - 55	3010132
	Black	60 - 110	3010158
	Pink	100 - 150	3090487
CB 5065/1 - 5080/1	Red	25 - 55	3010133
	Black	60 - 110	3010135
	Pink	100 - 150	3090456
	Grey	140 - 200	3090992
CB 50100/1	Red	25 - 55	3010134
	Black	60 - 110	3010136
	Pink	100 - 150	3090489
	Grey	140 - 200	3092174
CB 50125/1	Red	25 - 55	3010315
	Yellow	30 - 70	3010316
	Black	60 - 110	3010317
	Pink	100 - 150	3010318

RS 310-410-510-610/E-/EV MZ SERIES

The RS 310-410-510-610/E-/EV MZ burners series covers a firing range from 1300 to 6300 kW, and it has been designed for use in low or medium temperature hot water boilers, hot air or steam boilers, diathermic oil boilers.

It is based on the Digital Burner Management System, Riello REC27-37, which is able to manage the air-fuel ratio by independent servomotors in order to obtain a perfect output control and to assure a correct combustion and safe operation on all modulation range. Operation can be "two stage progressive" or, alternatively, "modulating" with the installation of a PID logic regulator and respective probes. RS/E-/EV MZ burners series guarantees high efficiency levels in all the various applications, thus reducing fuel consumption and running costs; specific versions are available to operate with Variable Speed Drive technology base on the control of a Frequency Inverter that modifies the air flow through the motor speed variation.

The exclusive design ensures reduced dimensions, simple use and maintenance.

A wide range of accessories guarantees elevated working flexibility.



RS 310/E-/EV MZ	600/1300 ÷ 3900 kW
RS 410/E-/EV MZ	800/2000 ÷ 4900 kW
RS 510/E-/EV MZ	800/2200 ÷ 5520 kW
RS 610/E-/EV MZ	820/2400 ÷ 6300 kW

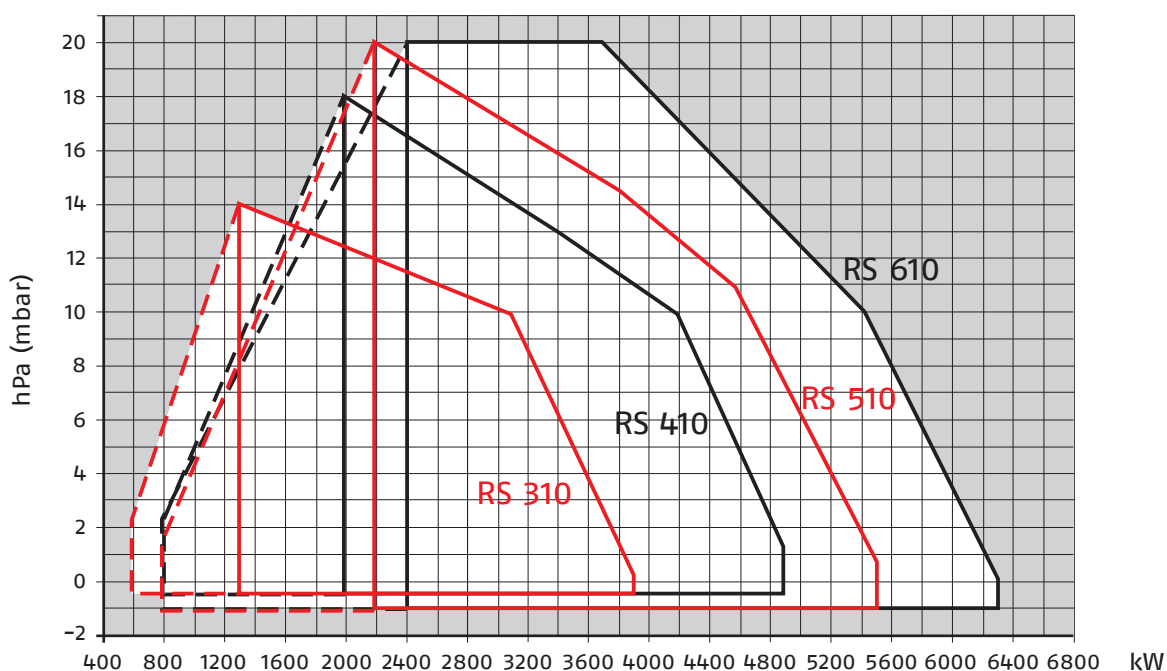

□ Useful working field for choosing the burner

--- Modulation range

Test conditions conforming to EN676
 Temperature: 20°C
 Pressure: 1013,5 mbar
 Altitude: 0 m a.s.l.

Modulating Gas Burners

RS 310-410-510-610/E-/EV MZ SERIES

Overall dimensions (mm)

BURNERS

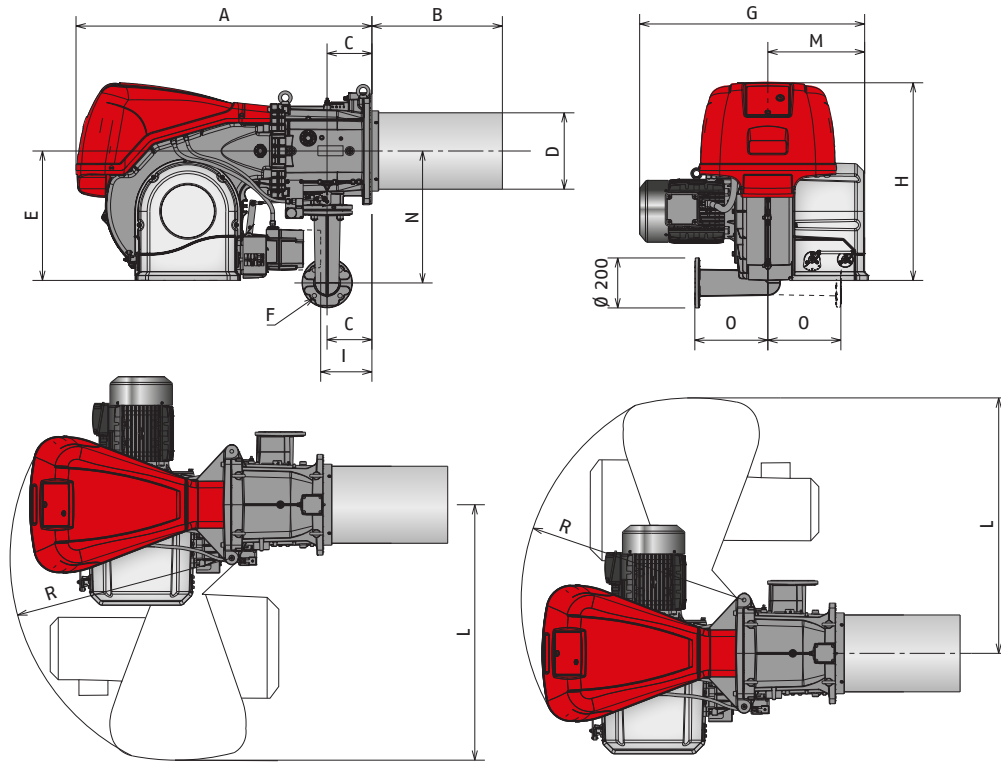

Model	A	B	C	D	E	F	G	H	I*	L	M	N	O	P	R
▶ RS 310/E-/EV MZ	1178	519	178	306	520	DN65	890	790	177	1015	400	528	290	177	890
▶ RS 410/E-/EV MZ	1178	519	178	306	520	DN65	908	790	177	1015	400	528	290	177	890
▶ RS 510/E-/EV MZ	1178	519	178	306	520	DN65	908	790	177	1015	400	528	290	177	890
▶ RS 610/E-/EV MZ	1178	519	178	330	520	DN65	980	790	177	1015	400	528	290	177	890

* Maximum position for the extraction of the servomotor cover in mechanical cam models.

BURNER - BOILER MOUNTING FLANGE

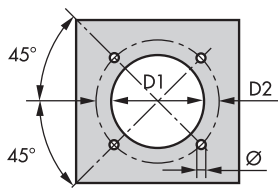

Model	D1	D2	Ø
▶ RS 310/E-/EV	335	452	M18
▶ RS 410/E-/EV	335	452	M18
▶ RS 510/E-/EV	335	452	M18
▶ RS 610/E-/EV	350	452	M18

PACKAGING

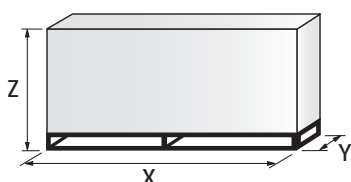

Model	X	Y	Z	kg
▶ RS 310/E-/EV	2040	1180	1125	250
▶ RS 410/E-/EV	2040	1180	1125	250
▶ RS 510/E-/EV	2040	1180	1125	250
▶ RS 610/E-/EV	2040	1180	1125	250

RS 310-410-510-610/E-/EV MZ SERIES

Specification

DESIGNATION OF SERIES

A specific index guides your choice of burner from the various models available in the RS/M MZ series. Below is a clear and detailed specification description of the product.

Series: R									
Fuel: S Natural Gas									
L Light oil									
LS Light oil/Natural Gas									
N Heavy oil									
Size:									
Setting: /1 Single stage									
/B Two stage									
/M Modulating-Mechanical cam									
/E Electronic cam									
/P Proportioning air/gas valve									
/EV Electronic cam predisposed for variable speed (with inverter)									
/EVi Electronic cam with integrated inverter									
Emission: ... or C01 Class 1 EN676									
MZ Class 2 EN676									
BLU Class 3 EN676									
MX Class 3 EN676									
Head length: TC standard head									
TL extended head									
Flame control system: FS1 Standard/Intermittent (at least 1 stop every 24 h)									
FS2 Continuous (1 stop every 72 h)									
Electrical supply to the system:									
1/230/50					1/230V/50Hz				
3/230/50					3/230V/50Hz				
3/400/50					3N/400V/50Hz				
3/230-400/50					3/230V/50Hz - 3N/400V/50Hz				
3/220/60					3/220V/60Hz				
3/380/60					3N/380V/60Hz				
3/220-380/60					3/220/60Hz - 3N/380V/60Hz				
Auxiliary voltage: 230/50-60 230V/50-60H									
110/50-60 110V/50-60Hz									
R	S	510	/E	MZ	TC	FS1	3/230-400/50	230/50-60	
BASIC DESIGNATION					EXTENDED DESIGNATION				

Specification

STATE OF SUPPLY

Monoblock forced draught burners with two stage progressive or modulating operation, with a specific kit, fully automatic, made up of:

- Microprocessor-based Digital Burner Management System (RS/E MZ models)
- Microprocessor-based Digital Burner Management System with Variable Speed Drive technology for the control of a Frequency Inverter (RS/EV MZ models)
- Display Interface operating unit to adjust the system
- Air suction circuit lined with sound-proofing material
- High performance fan with low sound emissions, forward curve blades
- Air damper for air flow setting and butterfly valve for regulating fuel output controlled by independent stepper motor actuators
- Air pressure switch
- Fan starting motor at 2900 rpm, three-phase 230/400 - 400/690 V with neutral, 50 Hz
- Combustion head, that can be set on the basis of required output, fitted with:
 - stainless steel end cone, resistant to corrosion and high temperatures
 - ignition electrodes; ionisation sensor for flame detection (or UV sensor on demand)
 - flame stability disk
- Maximum gas pressure switch, with pressure test point, for halting the burner in the case of over pressure on the fuel supply line
- Star/delta starter for the fan motor (Direct starter fan motor for RS 310-410 models)
- Main electrical supply terminal board
- Burner on/off switch
- Manual or automatic output increase/decrease switch
- Contacts motor and thermal relay with release button
- Burner failure led signal and lighted release button
- Burner opening hinge
- Lifting rings
- IP 54 electric protection level

Standard equipment:

Gasket for gas train adaptor

Adaptor for gas train

Screws for fixing the gas train adaptor: M 16 x 70

Thermal insulation screen

M 18 x 60 screws to secure the burner flange to the boiler

Cable grommets kit for optional electrical wiring input

M16 x 6 studs for fixing the gas elbow to the pipe coupling

M16 nuts to fix the gas elbow to the pipe coupling

Instruction handbook for installation, use and maintenance

Spare parts catalogue

Gas train

Fuel supply line, in the MULTIBLOC configuration (for a diameter of 1-1/2" and 2") or COMPOSED configuration (from a diameter of DN 65 until a diameter of DN 125), fitted with:

- Filter
- Stabiliser
- Minimum gas pressure switch
- Safety valve
- One stage working valve with ignition gas output regulator.

RS 310-410-510-610/E-/EV MZ SERIES

Specification

Conforming to:

- 2014/30/EU directive (electromagnetic compatibility)
- 2014/35/EU directive (low voltage)
- 2016/426/EU gas regulation (GAR)
- 2006/42 CE directive (machine)
- EN 676 (gas burners).

Available accessories to be ordered separately:

- Power controller
- Probe
- Continuous ventilation kit
- UV cell kit
- Variable speed drive (VSD) kit (for RS/EV series only)
- PC interface kit
- OCI412 Interface kit
- Sound proofing box
- Spacer kit
- Adapters
- PVP (Pressure Proving System)
- Stabiliser spring.

Modulating Gas Burners

RS 310-410-510-610/E-/EV MZ SERIES

Available models

Burners

CODE	MODEL				HEAT OUTPUT NATURAL GAS		TOTAL ELECTRICAL POWER (KW)	CERTIFICATION	NOTE
					(KW)	(Nm ³ /h)			
20068349	RS 310/E MZ	TC	FS1	3/230/50	600/1300-3900	40/120-363	9,1	CE-0085CP0166	
20068353	RS 310/E MZ	TC	FS1	3/400/50	600/1300-3900	40/120-363	9,1	CE-0085CP0166	
20068026	RS 310/E MZ	TC	FS1	3/400/50	600/1300-3900	40/120-363	8,8	CE-0085CP0166	(1)
20074260	RS 310/E MZ	TC	FS2	3/230/50	600/1300-3900	40/120-363	8,8	CE-0085CP0166	
20074261	RS 310/E MZ	TC	FS2	3/400/50	600/1300-3900	40/120-363	9,1	CE-0085CP0166	
20074264	RS 310/E MZ	TC	FS2	3/400/50	600/1300-3900	40/120-363	9,1	CE-0085CP0166	(1)
20068358	RS 410/E MZ	TC	FS1	3/230/50	800/2000-4900	50/150-445	10,6	CE-0085CP0166	
20068363	RS 410/E MZ	TC	FS1	3/400/50	800/2000-4900	50/150-445	10,6	CE-0085CP0166	
20067961	RS 410/E MZ	TC	FS1	3/400/50	800/2000-4900	50/150-445	10,6	CE-0085CP0166	(1)
20074262	RS 410/E MZ	TC	FS2	3/230/50	800/2000-4900	50/150-445	10,6	CE-0085CP0166	
20074263	RS 410/E MZ	TC	FS2	3/400/50	800/2000-4900	50/150-445	10,6	CE-0085CP0166	
20074265	RS 410/E MZ	TC	FS2	3/400/50	800/2000-4900	50/150-445	10,6	CE-0085CP0166	(1)
20068028	RS 510/E MZ	TC	FS1	3/400/50	800/2200-5520	68/180-525	13,9	CE-0085CP0166	(1)
20074266	RS 510/E MZ	TC	FS2	3/400/50	800/2200-5520	68/180-525	13,9	CE-0085CP0166	(1)
20067963	RS 610/E MZ	TC	FS1	3/400/50	820/2400-6300	100/220-625	16,9	CE-0085CP0166	(1)
20074267	RS 610/E MZ	TC	FS2	3/400/50	820/2400-6300	100/220-625	16,9	CE-0085CP0166	(1)
20074274	RS 310/EV MZ	TC	FS1/FS2	3/230/50	600/1300-3900	40/120-363	9,1	CE-0085CP0166	
20074275	RS 310/EV MZ	TC	FS1/FS2	3/400/50	600/1300-3900	40/120-363	9,1	CE-0085CP0166	
20074276	RS 410/EV MZ	TC	FS1/FS2	3/230/50	800/2000-4900	50/150-445	10,8	CE-0085CP0166	
20074277	RS 410/EV MZ	TC	FS1/FS2	3/400/50	800/2000-4900	50/150-445	10,8	CE-0085CP0166	
20074278	RS 510/EV MZ	TC	FS1/FS2	3/400/50	800/2200-5520	68/180-525	14	CE-0085CP0166	
20074279	RS 610/EV MZ	TC	FS1/FS2	3/400/50	820/2400-6300	100/220-625	17	CE-0085CP0166	

Natural gas, net calorific value: 10 kWh/Nm³ - Density: 0,71 kg/Nm³

The burners of RS/E-/EV MZ series are in according to 2016/426/EU - 2014/30/EU - 2014/35/EU - 2014/68/EU - 2006/42 CE Directives.

(1) Star delta starter

RS 310-410-510-610/E-/EV MZ SERIES

Available models

Gas Trains

CODE	GAS TRAIN MODEL	Ø	ADAPTER CODE			
			RS 310	RS 410	RS 510	RS 610
3970250*	MB 415/1 - RT 52	Rp 1" 1/2	3000826 + 20064220	●	●	●
3970257*	MB 420/1 - RT 52	Rp 2"	3000826 + 20042324	●	●	●
3970221*	MBC 1200/1 - RSM 60	Rp 2"	3000826 + 20042324			
3970222*	MBC 1900/1 - FSM 40	DN 65	3010221			
3970223*	MBC 3100/1 - FSM 40	DN 80	3010222			
3970224*	MBC 5000/1 - FSM 80	DN 100	3010222 - 3010370			
3970145*	CB 512/1 - RSM 30	Rp 1" 1/2	3000826 + 20064220		●	●
3970146*	CB 520/1 - RSM 30	Rp 2"	3000826 + 20042324			●
20044659*	CB 525/1 - RSM 30	Rp 2"	3000826 + 20042324			
3970147*	CB 5065/1 - FSM 30	DN 65	3010221			
3970148*	CB 5080/1 - FSM 30	DN 80	3010222			
3970149*	CB 50100/1 - FSM 30	DN 100	3010223 - 3010370			
20015871*	CB 50125/1 - FSM 30	DN 125	3010224			

Please see designation of Gas Train Series in the page before the Catalogue index.

* 230V/50Hz -220V/60Hz electrical supply.

** 230V/50Hz electrical supply.

The valves seal control device is compulsory (conforming to EN 676) on gas trains to burners with a maximum output over 1200 kW.

The seal control function is managed by REC control box, by installation on gas train of a pressure switch (please see Gas train accessories paragraph).

To select the gas train please refer to the technical data leaflet and/or instruction manual.

● Not available.

□ Additional adapter not necessary, the gas train may be connected directly to the burner.

Modulating Gas Burners

RS 310-410-510-610/E-/EV MZ SERIES

Burner accessories

Accessories for modulating operation

POWER CONTROLLER



To obtain modulating operation, the RS/E/EV MZ series of burners requires a regulator with three point outlet controls. The following table lists the accessories for modulating operation with their application range.

For remote setpoint use RWF 55.

BURNER	TYPE	KIT CODE
▶ All models	RWF 50.2 - Basic version with 3 position output	20073595
	RWF 55.5 - Complete with RS-485 interface	20074441
	RWF 55.6 - Complete with RS-485/ PROFIBUS interface	20074442

PROBE



The relative temperature or pressure probes fitted to the power controller must be chosen on the basis of the application.

BURNER	TYPE	RANGE (°C) (BAR)	KIT CODE
▶ All models	Temperature PT 100	-100 ÷ 500°C	3010110
	Pressure 4 ÷ 20 mA	0 ÷ 2,5 bar	3010213
	Pressure 4 ÷ 20 mA	0 ÷ 16 bar	3010214
	Pressure 4 ÷ 20 mA	0 ÷ 25 bar	3090873

Continuous ventilation kit



If the burner requires continuous ventilation in the stages without flame, a special kit is available as given in the following table:

BURNER	KIT CODE
▶ RS 310-410-510-610/E	20074542

Uv cell kit



A UV cell is available for the supervision of the flame alternatively to ionisation probe for special applications.

BURNER	KIT CODE
▶ RS 310-410-510-610/E-/EV	20077814

Pc interface kit



To connect the control panel to a personal computer for the transmission of operation, fault signals and detailed service information, an interface adapter with PC software are available.

BURNER	KIT CODE
▶ RS 310-410-510-610/E-/EV (ACS410 + OCI410.30) - Service level	3010436

RS 310-410-510-610/E-/EV MZ SERIES

Burner accessories

Variable Speed Drive (VSD) for RS/EV series only



The motor speed variation for the RS/EV BLU burners series is obtained thanks to a frequency converter: variable speed drive (VSD), provided with a programming panel with start-up assistant. It always must be ordered with RS/EV series.

BURNER	ELECTRICAL SUPPLY	MOTOR POWER (kW)	INVERTER POWER (kW)	KIT CODE
▶ RS 310/EV	230	7,5	7,5	On demand
▶ RS 310/EV	400	7,5	7,5	20163074
▶ RS 410/EV	230	9,2	11	On demand
▶ RS 410/EV	400	9,2	11	20163093
▶ RS 510/EV	400	12	15	20163096
▶ RS 610/EV	400	15	15	20163096

The use of inverters other than those indicated by the manufacturer may lead to burner failure and, in extreme cases, a potential risk of harm to people and damage to property. The manufacturing company shall not be liable for any such damage arising from non-observance of the requirements contained in the burner manual.

OCI412 interface kit



Interface kit between the REC 27.1 and a Modbus system, such as a building automation and control system (BACS). The Modbus interface is based on the RS-485 standard.

BURNER	KIT CODE
▶ RS 310-410-510-610/E-/EV	3010437

Sound proofing box

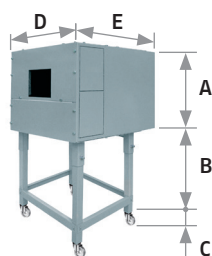

If noise emission needs reducing even further, sound-proofing boxes are available.

When a lower "B" dimension is required, it is available the Box Support Kit code 20065135 which allows to reduce it at the fixed dimension of 55 mm.

The sound-proofing boxes are not suitable for outdoor use.

BURNER	BOX TYPE	A (mm)	B (mm) min. - max	C (mm)	D (mm)	E (mm)	[dB(A)] (*)	KIT CODE
▶ RS 310-410/E-/EV	C7	1255	160 - 980	110	1140	1345	10	3010376
▶ RS 610/E-/EV	C7 PLUS	1255	270 - 1090	110	1240	1345	10	20085111
▶ RS 310-410/E-/EV RS510/E-/EV	C7	1255	165	110	1140	1345	10	20027778

(*) Average noise reduction according to EN 15036-1 standard

Spacer kit

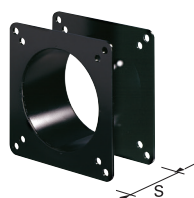





If burner head penetration into the combustion chamber needs reducing, varying thickness spacers are available, as given in the following table:

BURNER	Spacer thickness S (mm)	KIT CODE
▶ All models	180	20008903

Gas train accessories

Adapters

In certain cases, an adapter must be fitted between the gas train and the burner, when the diameter of the gas train is different from the set diameter of the burner. Below are given the available adapters; please see on the Gas Train list the correct adapter codes to select.

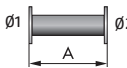
ADAPTER	DIMENSIONS				ADAPTER CODE
	ø1 DN	ø2 DN	A mm	B mm	
1" 1/2  2"	-	-	65	-	20064220
2"  2"	-	-	65	-	20042324
DN 80  2" 1/2  2"	-	-	300	-	3000826
	65	80	400	-	3010221
	80	80	400	-	3010222
	100	80	400	-	3010223
	125	80	320	-	3010224

PVP (pressure valve proving kit)*

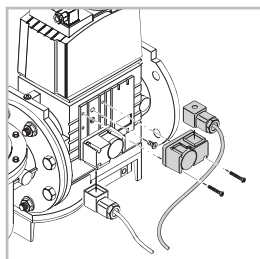

The seal control function is included on Burner Digital Management System, it is only necessary to add the PVP kit on the gas train.

GAS TRAIN	CODE
► MB - CB - MBC type	3010344

RS 310-410-510-610/E-/EV MZ SERIES

Stabiliser spring



To vary the pressure range of the gas train stabilisers, accessory springs are available. The following table shows these accessories with their application range. Please refer to the technical manual for the correct choice of spring.

GAS TRAIN	SPRING COLOUR	SPRING Pressure range mbar	SPRING CODE
MBC 1900/1 - 3100/1 MBC 5000/1	White	4 - 20	3010381
	Red	20 - 40	3010382
	Black	40 - 80	3010383
CB 512/1	Green	80 - 150	3010384
	Red	25 - 55	3010131
	Black	60 - 110	3010157
CB 520/1 - 525/1	Pink	90 - 150	3090486
	Red	25 - 55	3010132
	Black	60 - 110	3010158
CB 5065/1 - 5080/1	Pink	100 - 150	3090487
	Red	25 - 55	3010133
	Black	60 - 110	3010135
CB 50100/1	Pink	100 - 150	3090456
	Grey	140 - 200	3090992
	Red	25 - 55	3010134
CB 50125/1	Black	60 - 110	3010136
	Pink	100 - 150	3090489
	Grey	140 - 200	3092174
CB 50125/1	Red	25 - 55	3010315
	Yellow	30 - 70	3010316
	Black	60 - 110	3010317
	Pink	100 - 150	3010318

RS 1000÷1200/M C01 SERIES

The well-known RS 300-800/M Burner Series, till now available up to 8 MW, has been upgraded with two new powerful burner models, the RS 1000-1200/M models that extend his max output up to 12 MW and make the Burner Series even more complete and suitable for matching with the various Heat and Steam Generators in today's market. The New Burner Models take the reliability of combustion and the solidity typical of Riello's Burners and match them with the most advanced solutions on Power Output Control and Ventilation Technology; as result a 12 MW output is supplied with a User Friendly monoblock machine assuring easiness of installation and servicing, and safe operation. An easy access to internal components is ensured by the burner opening hinge.



The New Gas Models are available with Modulating operation managed through Mechanical Cam, for a simple commissioning and to supply with precision the demanded power, guaranteeing high efficiency and setting stability, obtaining fuel consumption and operating costs reduction.

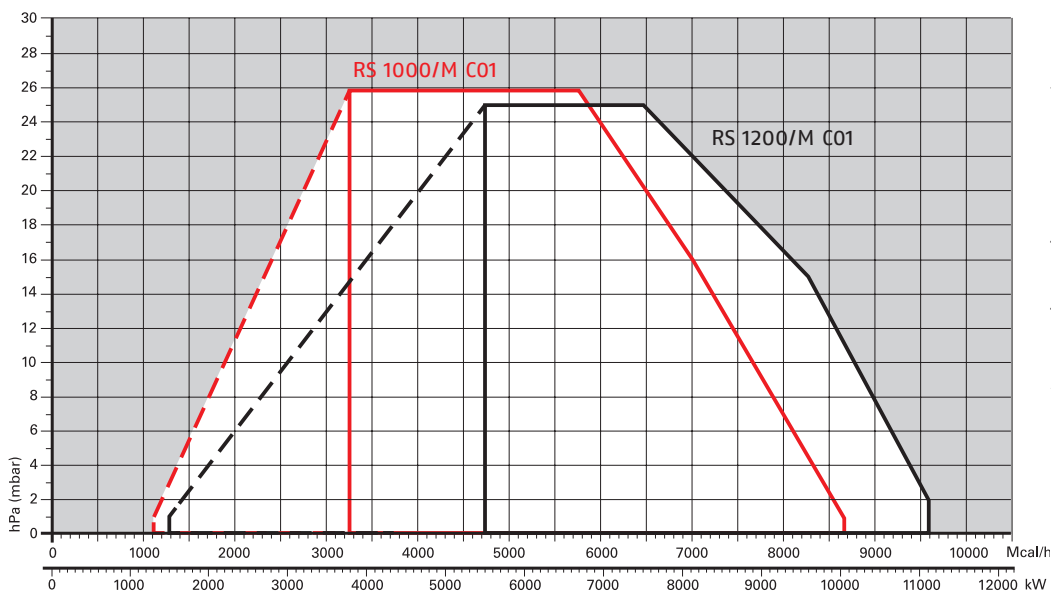

RS 1000/M C01	1100/4000 ÷ 10100 kW
RS 1200/M C01	1500/5500 ÷ 11100 kW

FIRING RATES



-  Useful working field for choosing the burner
-  Modulation range
- Test conditions conforming to EN676
- Temperature: 20°C
- Pressure: 1013,5 mbar
- Altitude: 0 m a.s.l.

Modulating Gas Burners

RS 1000-1200/M C01 SERIES

Overall dimensions (mm)

BURNER

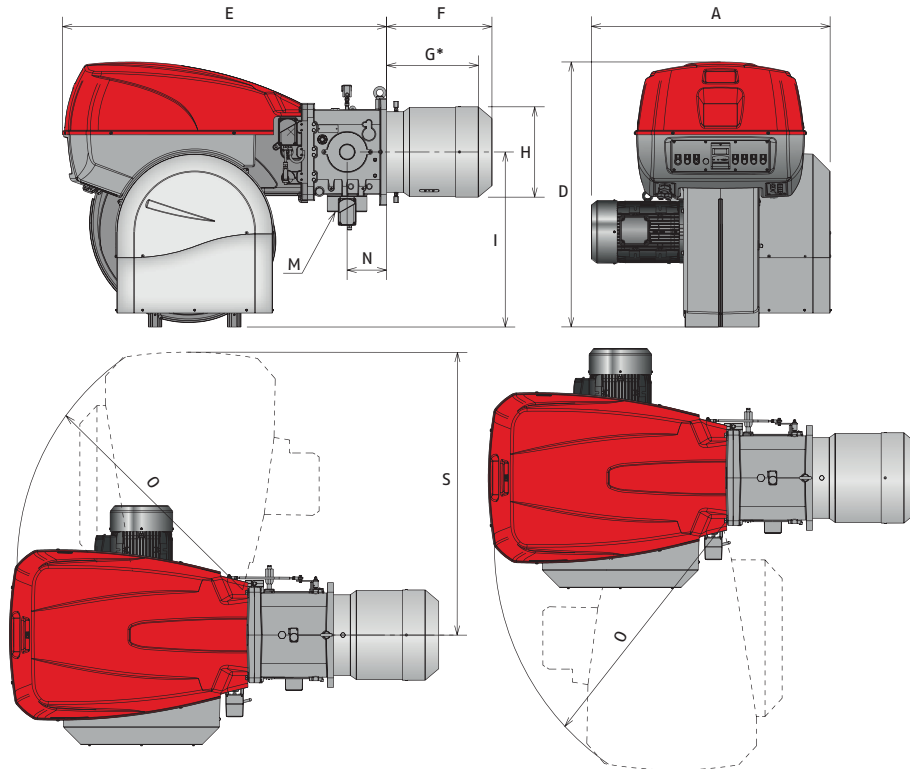

MODEL	A	D	E	F	G*	H	I	M	N	O	S
▶ RS 1000/M C01	1206	1338	1637	538	485	413	885	DN80	200	1350	1493
▶ RS 1200/M C01	1250	1338	1637	539	485	456	885	DN80	200	1350	1493

* Maximum depth of the boiler door including the depth of the burner flange insulating gasket.

BURNER - BOILER MOUNTING FLANGE

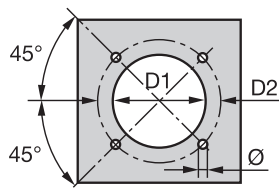

MODEL	D1	D2	Ø
▶ RS 1000/M C01	460	608	M20
▶ RS 1200/M C01	500	608	M20

PACKAGING

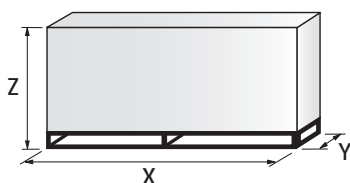

MODEL	X	Y	Z	kg
▶ RS 1000/M C01	2400	1400	1595	500
▶ RS 1200/M C01	2400	1400	1595	550

Specification

DESIGNATION OF SERIES

Series: R									
Fuel: S Natural Gas									
L Light oil									
LS Light oil/Natural Gas									
N Heavy oil									
Size:									
Setting: /1 Single stage									
/B Two stage									
/M Modulating-Mechanical cam									
/E Electronic cam									
/P Proportioning air/gas valve									
/EV Electronic cam predisposed for variable speed (with inverter)									
/EVi Electronic cam with integrated inverter									
Emission: ... or C01									
					Class 1 EN676				
MZ					Class 2 EN676				
BLU					Class 3 EN676				
MX					Class 3 EN676				
Head length: TC standard head									
TL extended head									
Flame control system: FS1 Standard/Intermittent (at least 1 stop every 24 h)									
FS2 Continuous (1 stop every 72 h)									
Electrical supply to the system:									
1/230/50					1/230V/50Hz				
3/230/50					3/230V/50Hz				
3/400/50					3N/400V/50Hz				
3/230-400/50					3/230V/50Hz - 3N/400V/50Hz				
3/220/60					3/220V/60Hz				
3/380/60					3N/380V/60Hz				
3/220-380/60					3/220/60Hz - 3N/380V/60Hz				
Auxiliary voltage: 230/50-60									
					230V/50-60H				
					110V/50-60Hz				
R	S	1000	/M	C01	TC	FS1	3/230-400/50	230/50-60	
BASIC DESIGNATION									
EXTENDED DESIGNATION									

Specification

STATE OF SUPPLY

Monoblock forced draught gas burner with modulating operation, fully automatic, made up of:

- Fan with reverse curve blades high performance
- Air suction circuit lined with sound-proofing material
- Air damper for air setting controlled by a high precision servomotor
- Air pressure switch
- Fan starting motor at 2900 rpm, three-phase 230/400 - 400/690 V with neutral, 50 Hz
- Low emission combustion head, that can be set on the basis of required output, fitted with:
 - stainless steel end cone, resistant to corrosion and high temperatures
 - ignition by gas pilot with gas train
 - flame stability disk
- Maximum gas pressure switch, with pressure test point, for halting the burner in the case of over pressure on the fuel supply line
- Burner safety control box for controlling the system safety (RFG0 for FS1 intermittent operation - LGK16 for FS2 continuous operation)
- UV photocell for flame detection
- Star/delta starter for the fan motor
- Main electrical supply terminal board
- Burner on/off switch
- Auxiliary voltage led signal
- Manual or automatic output increase/decrease switch
- Burner working led signal
- Contacts motor and thermal relay with release button
- Motor internal thermal protection
- Motor failure led signal
- Burner failure led signal and lighted release button
- Led signal for correct rotation direction of fan motor
- Emergency button
- Coded connection plugs-sockets
- Burner opening hinge
- Lifting rings
- IP 54 electric protection level

Standard equipment:

- 1 flange gasket
- 8 screws for fixing the flange
- 1 thermal screen
- 4 screws for fixing the burner flange to the boiler
- DN 80 gas supply connector for gas train connection
- Instruction handbook for installation, use and maintenance
- Spare parts catalogue.

Modulating Gas Burners

RS 1000÷1200/M C01 SERIES

RIELLO

Available models

Burners

CODE	MODEL					HEAT OUTPUT		TOTAL ELECTRICAL POWER (kW)	NOTE
						NATURAL GAS			
						(kW)	(Nm ³ /h)		
20145938	RS 1000/M C01	TC	FS1/FS2	3/400/50	230/50-60	1100/4000-10100	130/380-940	24	(1)(2)(4)
20145936	RS 1200/M C01	TC	FS1/FS2	3/400/50	230/50-60	1500/5500-11100	150/550-1150	27.2	(1)(2)(4)

Natural gas, net calorific value: 10 kWh/Nm³ - Density: 0,71 kg/Nm³

(1) according to 2014/30/EU - 2014/35/EU - 2006/42/EU - 2014/68/EU Directives

(2) with RFG0 control box

(3) with LFL control box

(4) FS2 operation is allowed with ionization probe only, no other flame sensors can be used

Due to the improvement applied on the technical specification of some products, some burner codes will change during year 2019. The table below summarizes the correspondence between the previous and the new code.

MODEL				NEW CODE		OLD CODE	
RS 1000/M C01	TC	FS1/FS2	3/400/50	20145938	(2)(4)	20061873	(3)
RS 1200/M C01	TC	FS1/FS2	3/400/50	20145936	(2)(4)	20061850	(3)

Gas Trains

CODE	GAS TRAIN				VPS CODE	ADAPTER CODE	
	MODEL	∅	C.T.			RS 1000	RS 1200
3970221*	MBC 1200/1 - RSM 60	Rp 2"	-	3010123			
3970225**	MBC 1200/1 CT RSM 60	Rp 2"	◆	-	20066263 / (20065924 + 20066263) ¹		
3970222*	MBC 1900/1 - FSM 40	DN 65	-	3010123			
3970226**	MBC 1900/1 CT FSM 40	DN 65	◆	-	20066263 / (20065924 + 20066263) ¹		
3970223*	MBC 3100/1 - FSM 40	DN 80	-	3010123			
3970227**	MBC 3100/1 CT FSM 40	DN 80	◆	-	20066268 / (20065937 + 20066268) ¹		
3970224*	MBC 5000/1 - FSM 80	DN 100	-	3010123			
3970228**	MBC 5000/1 CT FSM 80	DN 100	◆	-	20066278 / (20065960 + 20066278) ¹		
20044659*	CB 525/1 - RSM 30	Rp 2"	-	3010123	20066263 / (20065924 +	●	
20044660**	CB 525/1 CT RSM 30	Rp 2"	◆	-	20066263) ¹	●	
3970147*	CB 5065/1 - FSM 30	DN 65	-	3010123			
3970161**	CB 5065/1 CT FSM 30	DN 65	◆	-	20066263 / (20065924 + 20066263) ¹		
3970148*	CB 5080/1 - FSM 30	DN 80	-	3010123			
3970162**	CB 5080/1 CT FSM 30	DN 80	◆	-	20066268 / (20065937 + 20066268) ¹		
3970149*	CB 50100/1 - FSM 30	DN 100	-	3010123			
3970163**	CB 50100/1 CT FSM 30	DN 100	◆	-	20066278 / (20065960 + 20066278) ¹		
20015871*	CB 50125/1 - FSM 30	DN 125	-	3010123			
3970196**	CB 50125/1 CT FSM 30	DN 125	◆	-	20066284 / (20065968 + 20066284) ¹		

Please see designation of Gas Train Series in the page before the Catalogue index.

* 230V/50Hz - 220V/60Hz electrical supply.

** 230V/50Hz electrical supply.

The valve seal control device is compulsory (conforming to EN 676) on gas trains to burners with a maximum output over 1200 kW.

To select the gas train please refer to the technical data leaflet and/or instruction manual.

C.T. Gas valve leak detection control device:

- gas train not equipped with leak detection control device; this device can be ordered separately - see VPS column - and installed later.

◆ gas train equipped with leak detection control device.

VPS Valve leak detection control device. Supplied separately from the gas train (please see Gas train accessories paragraph for both 50 Hz and 60 Hz codes).

● Not available.

□ Additional adapter not necessary, the gas train may be connected directly to the burner.

1) To be used with gas train and burner opening on the left (fan motor side).

2) To be used with /M (mechanical cam) burners, gas train on the left (fan motor side) and burner opening on the right.

Modulating Gas Burners

RS 1000÷1200/M C01 SERIES

Burner accessories

Accessories for modulating operation

POWER CONTROLLER



To obtain modulating operation, the RS/M C01 series of burners requires a regulator with three point outlet controls. The following table lists the accessories for modulating operation with their application range. For remote setpoint use RWF 55.

BURNER	TYPE	KIT CODE
► All models	RWF 50.2	20101190
	RWF 55.5	20101191

PROBE



The relative temperature or pressure probes fitted to the power controller must be chosen on the basis of the application.

BURNER	TYPE	RANGE (°C) (bar)	KIT CODE
► All models	Temperature PT 100	-100 ÷ 500°C	3010110
	Pressure 4 ÷ 20 mA	0 ÷ 2,5 bar	3010213
	Pressure 4 ÷ 20 mA	0 ÷ 16 bar	3010214
	Pressure 4 ÷ 20 mA	0 ÷ 25 bar	3090873

ANALOG CONTROL SIGNAL CONVERTER



BURNER	TYPE (INPUT SIGNAL)	KIT CODE
► All models	0/2 - 10 V (impedance 200 K Ω) 0/4 - 20 mA (impedance 250 Ω)	3010390

POTENTIOMETER



BURNER	KIT CODE
► RS 1000-1200/M C01	-

Continuous ventilation kit



If the burner requires continuous ventilation in the stages without flame, a special kit is available as given in the following table:

BURNER	KIT CODE
► All models	20086519

Burner accessories

Sound proofing box

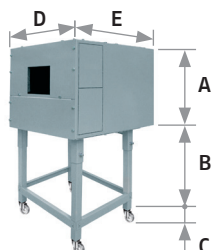

If noise emission needs reducing even further, sound-proofing boxes are available. When a lower "B" dimension is required, it is available the Box Support Kit code 20065135 which allows to reduce it at the fixed dimension of 55 mm. The sound-proofing boxes are not suitable for outdoor use.

BURNER	BOX TYPE	A (mm)	B (mm) min-max	C (mm)	D (mm)	E (mm)	[dB(A)] (*)	BOX CODE
► RS 1000-1200/M C01	C8	1425	285 - 1000	110	1500	1800	10	3010401

(*) Average noise reduction according to EN 15036-1 standard

Gas train accessories

Adapters

In certain cases, an adapter must be fitted between the gas train and the burner, when the diameter of the gas train is different from the set diameter of the burner. Below are given the available adapters; please see on the Gas Train list the correct adapter codes to select.

ADAPTER	DIMENSIONS				ADAPTER CODE
	Ø1 DN	Ø2 DN	A mm	B mm	
	2"	65 / 80	780	230	20068058
	2"	65 / 80	230	375	20066253
	65	65 / 80	230	375	20066263
	80	65 / 80	230	375	20066268
	100	65 / 80	230	375	20066278
	125	65 / 80	245	375	20066284
	65	65	800	-	20065924
	80	80	800	-	20065937
	100	100	800	-	20065960
	125	125	800	-	20065968
	125	125	800	-	20065968

Modulating Gas Burners

RS 1000÷1200/M C01 SERIES

Gas train accessories

Stabiliser spring



To vary the pressure range of the gas train stabilisers, accessory springs are available. The following table shows these accessories with their application range. Please refer to the technical manual for the correct choice of spring.

GAS TRAIN	SPRING COLOUR	SPRING PRESSURE RANGE mbar	SPRING CODE
▶ MBC 1900/1 – 3100/1 MBC 5000/1	White	4 – 20	3010381
	Red	20 – 40	3010382
	Black	40 – 80	3010383
	Green	80 – 150	3010384
▶ CB 5065/1 – 5080/1	Red	25 – 55	3010133
	Black	60 – 110	3010135
	Pink	100 – 150	3090456
	Grey	140 – 200	3090992
▶ CB 50100/1	Red	25 – 55	3010134
	Black	60 – 110	3010136
	Pink	100 – 150	3090489
▶ CB 50125/1	Grey	140 – 200	3092174
	Red	25 – 55	3010315
	Yellow	30 – 70	3010316
	Black	60 – 110	3010317
	Pink	100 – 150	3010318

Seal control kit



To test the valve seals on the gas train, a special “seal control kit” is available. The valve seal control device is compulsory (EN 676) on gas trains to burners with a maximum output over 1200 kW. The seal control is type VPS 504.

GAS TRAIN	KIT CODE for 50 Hz operation	KIT CODE for 60 Hz operation
▶ MBC/1 type	3010123	20168805
▶ CB/1 type	3010123	20168805

RS 1000÷2000/E-/EV C01 SERIES

The well-known RS 1000-1200/E-EV Burner Series, till now The RS/E and RS/EV C01 burners series are characterised by a modular monoblock structure that means all necessary components can be combined in a single unit thus making installation easier, faster and, above all, more flexible.

The burners cover a firing range from 4000 to 19500 kW, and they have been designed for use in hot water boilers or industrial steam generators.

Operation can be modulating on the RS/E series and modulating with variable speed drive operation on RS/EV series.

The mechanisms of regulation allow to catch up a high modulation ratio on all firing rates range.

The burner can, therefore, supply with precision the demanded power, guaranteeing an high efficiency system level and the stability setting, obtaining fuel consumption and operating costs reduction.

The burner operation can be intermittent or continuous by menu setting.

The innovative combustion head, adjustment system ensures perfect movement during modulation.



RS 1000/E-/EV C01	1100/4000 ÷ 10100 kW
RS 1200/E-/EV C01	1500/5500 ÷ 11100 kW
RS 1300/E-/EV C01	2500/7500 ÷ 13000 kW
RS 1600/E-/EV C01	3065/9503 ÷ 15560 kW
RS 2000/E-/EV C01	4000/12000 ÷ 19500 kW

Modulating Gas Burners

RS 1000-2000/E-/EV C01 SERIES

FIRING RATES

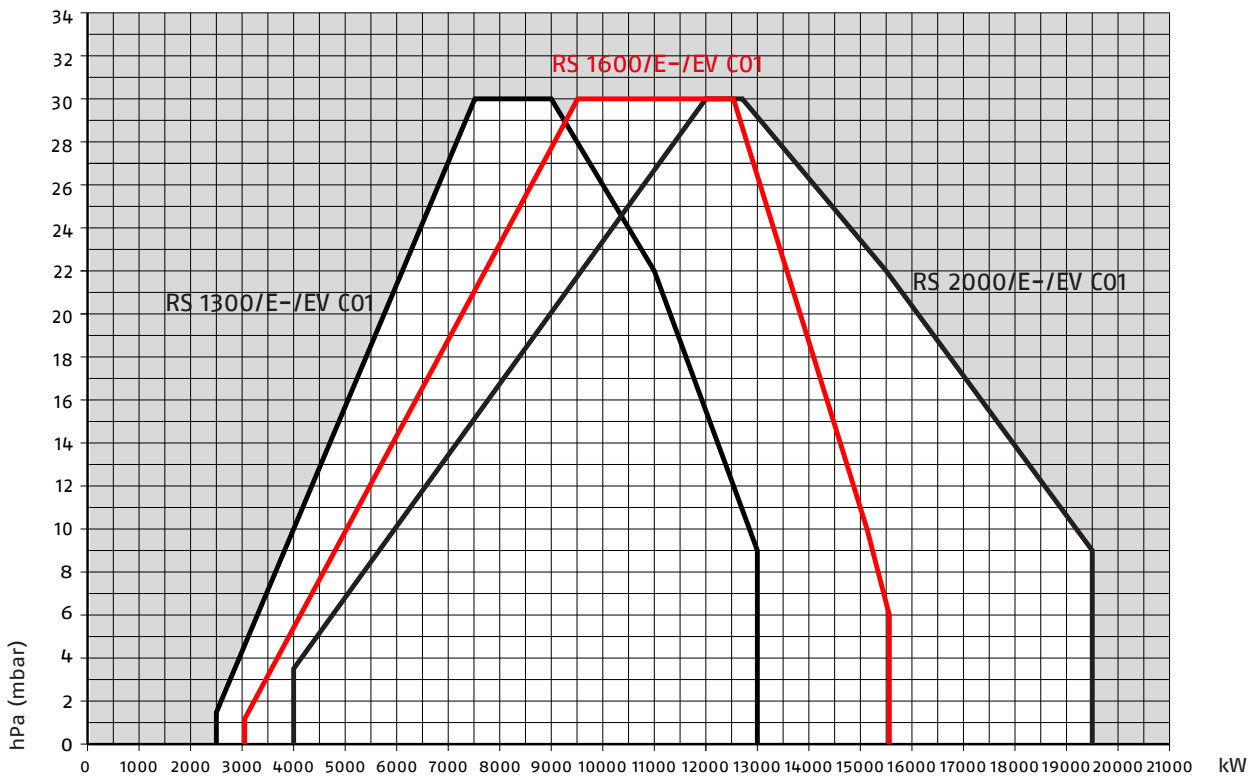
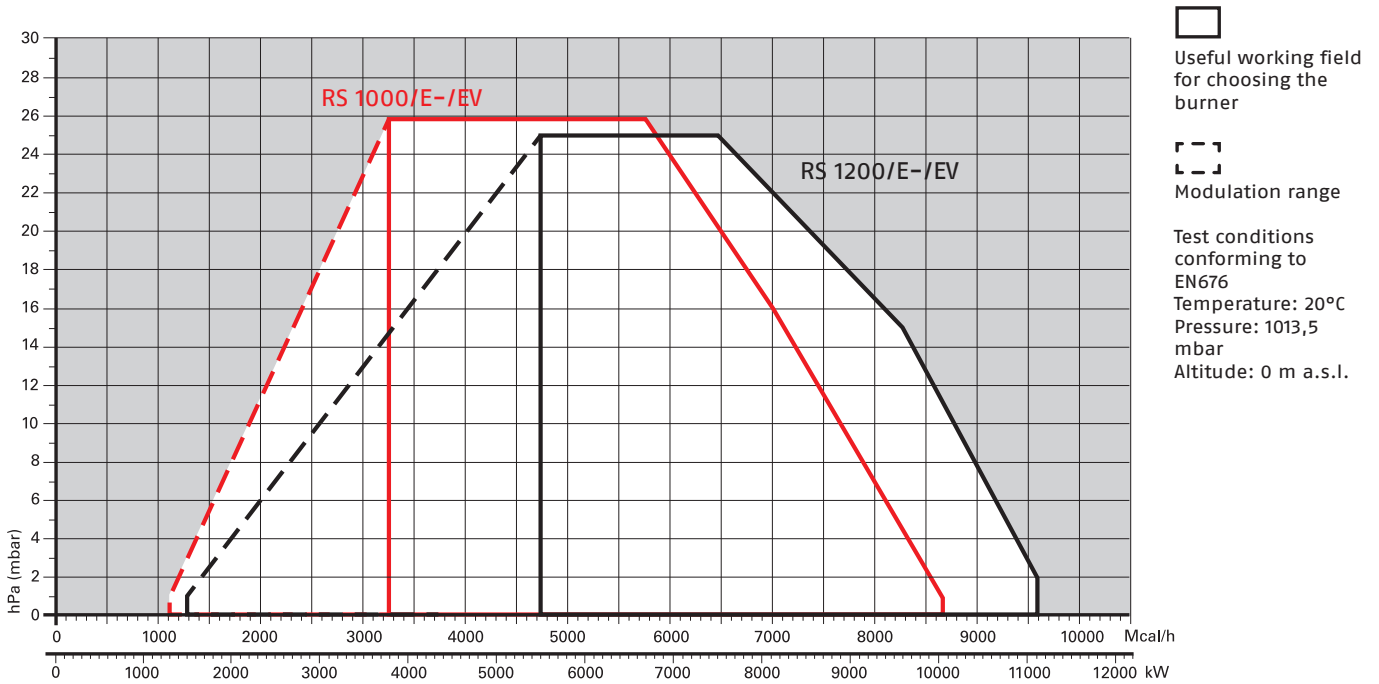

Modulating Gas Burners

RS 1000-2000/E-/EV C01 SERIES

RIELLO

Overall dimensions (mm)

BURNER

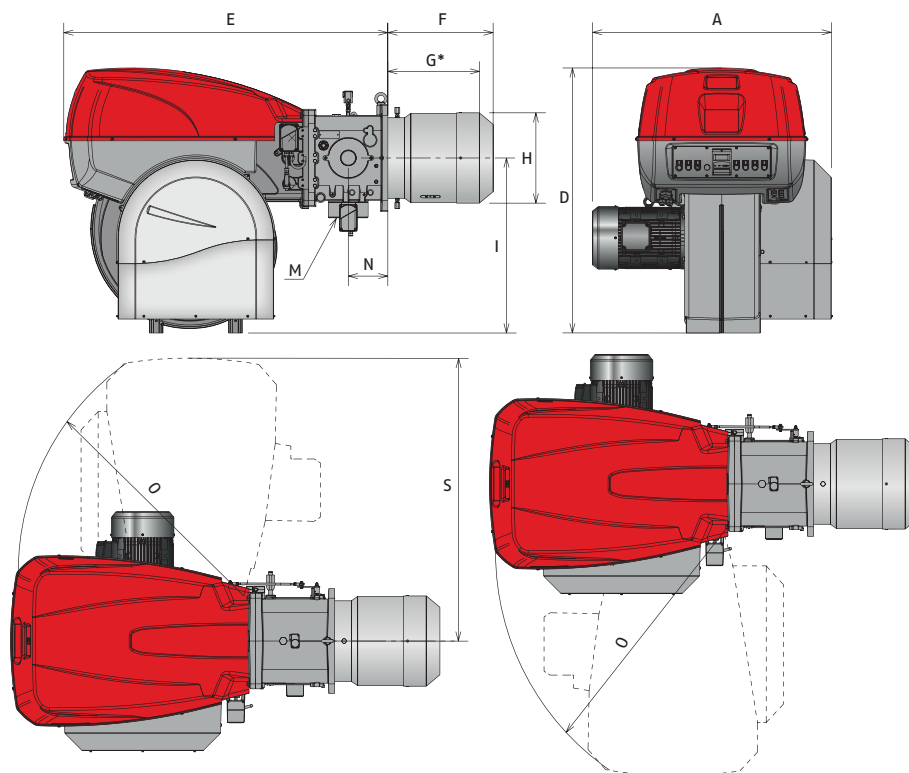

MODEL	A	D	E	F	G*	H	I	M	N	O	S
▶ RS 1000/E-EV C01	1206	1338	1637	538	485	413	885	DN80	200	1350	1493
▶ RS 1200/E-EV C01	1250	1338	1637	539	485	456	885	DN80	200	1350	1493

* Maximum depth of the boiler door including the depth of the burner flange insulating gasket.

BURNER - BOILER MOUNTING FLANGE

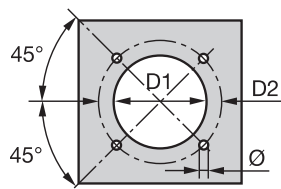

MODEL	D1	D2	Ø
▶ RS 1000/E-EV C01	460	608	M20
▶ RS 1200/E-EV C01	500	608	M20

PACKAGING

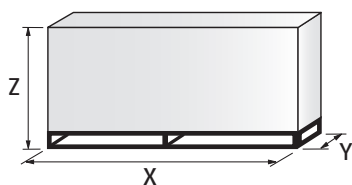

MODEL	X	Y	Z	kg
▶ RS 1000/E-EV C01	2400	1400	1595	500
▶ RS 1200/E-EV C01	2400	1400	1595	550

GAS

Modulating Gas Burners

RS 1000÷2000/E-/EV C01 SERIES

Overall dimensions (mm)

BURNER

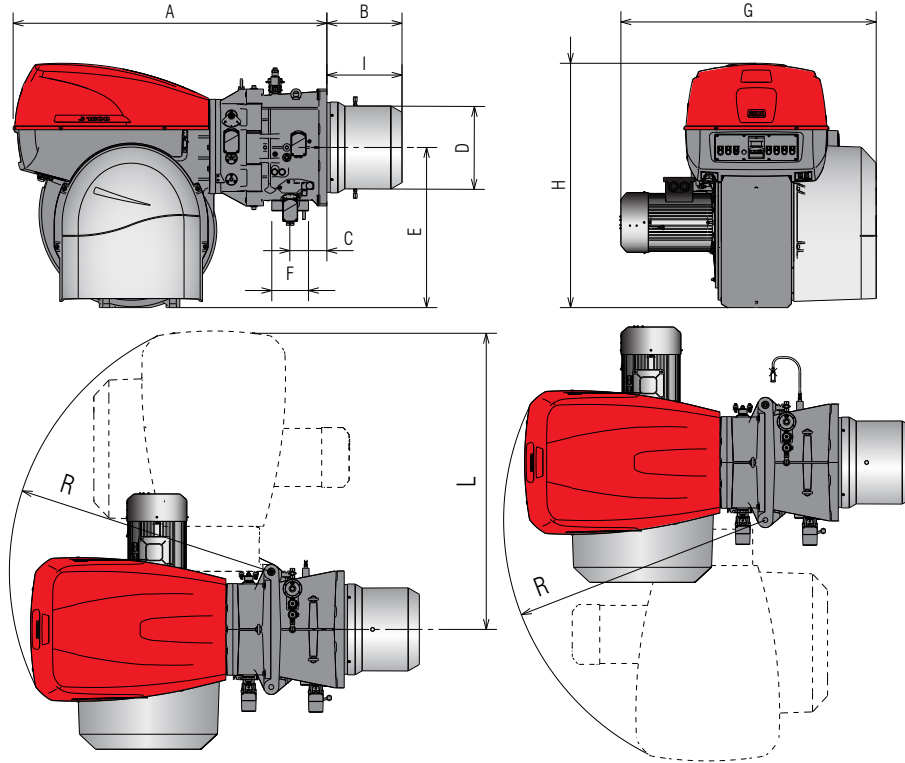

MODEL	A	B	C	D	E	F	G	H	I	L	R
▶ RS 1300/E-EV C01	1880	450	220	544	960	DN 80	1585	1463	383	1782	1565
▶ RS 1600/E-EV C01	1880	450	220	544	960	DN 80	1530	1463	383	1785	1565
▶ RS 2000/E-EV C01	1880	450-610	220	544	960	DN 80	1560	1463	383-543	1782	1565

BURNER - BOILER MOUNTING FLANGE

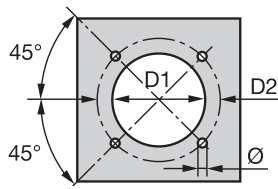

MODEL	D1	D2	Ø
▶ RS 1300/E-EV C01	580	645	M20
▶ RS 1600/E-EV C01	580	645	M20
▶ RS 2000/E-EV C01	580	645	M20

PACKAGING

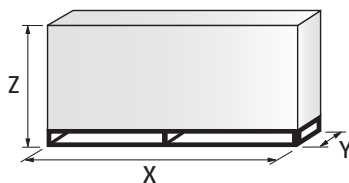

MODEL	X	Y	Z	kg
▶ RS 1300/E-EV C01	3000	1800	1750	1180
▶ RS 1600/E-EV C01	3000	1800	1750	1180
▶ RS 2000/E-EV C01	3000	1800	1750	1180

Modulating Gas Burners

RS 1000÷2000/E-/EV C01 SERIES

RIELLO

Specification

DESIGNATION OF SERIES

Series: R									
Fuel: S Natural Gas									
L Light oil									
LS Light oil/Natural Gas									
N Heavy oil									
Size:									
Setting: /1 Single stage									
/B Two stage									
/M Modulating-Mechanical cam									
/E Electronic cam									
/P Proportioning air/gas valve									
/EV Electronic cam predisposed for variable speed (with inverter)									
/EVi Electronic cam with integrated inverter									
Emission: ... or C01					Class 1 EN676				
MZ					Class 2 EN676				
BLU					Class 3 EN676				
MX					Class 3 EN676				
Head length: TC standard head									
TL extended head									
Flame control system: FS1 Standard/Intermittent (at least 1 stop every 24 h)									
FS2 Continuous (1 stop every 72 h)									
Electrical supply to the system:									
1/230/50		1/230V/50Hz							
3/230/50		3/230V/50Hz							
3/400/50		3N/400V/50Hz							
3/230-400/50		3/230V/50Hz - 3N/400V/50Hz							
3/220/60		3/220V/60Hz							
3/380/60		3N/380V/60Hz							
3/220-380/60		3/220/60Hz - 3N/380V/60Hz							
Auxiliary voltage: 230/50-60 230V/50-60H									
110/50-60 110V/50-60Hz									
R	S	1000	/E	C01	TC	FS2	3/230-400/50	230/50-60	
BASIC DESIGNATION									
EXTENDED DESIGNATION									

GAS

Specification

STATE OF SUPPLY

Monoblock forced draught gas burner with modulating operation, fully automatic, made up of:

- High performance fan with reverse curve blades for RS 1000-1200 and forward curve blades for RS 1300-1600-2000
- Air suction circuit lined with sound-proofing material
- Air damper for air setting controlled by a high precision servomotor
- Air pressure switch
- Fan starting motor at 2900 rpm, three-phase 400/690 V with neutral, 50Hz
- Mobile combustion head, that can be set on the basis of required output, fitted with:
 - stainless steel end cone, resistant to corrosion and high temperatures
 - ignition by gas pilot with gas train
 - flame stability disk
- Automatic regulator for gas delivery, controlled by a high precision servomotor
- Maximum gas pressure switch, with pressure test point, for halting the burner in the case of over pressure on the fuel supply line
- Module for air/fuel setting and output modulation with incorporated PID control of temperature or pressure of the heat generator (LMV 51.100 on RS/E C01, LMV 52 on RS/EV C01)
- AZL Display Interface, for combustion system commissioning and monitoring, included in both RS/E and /EV models
- Burner safety control included on Electronic Cam device
- IRD sensor for flame detector
- Star/delta starter for the fan motor
- Main electrical supply terminal board
- Burner on/off switch
- Auxiliary voltage led signal
- Burner working led signal
- Contacts motor and thermal relay with release button
- Motor internal thermal protection
- Motor failure led signal
- Burner failure led signal and lighted release button
- Emergency button
- Coded connection plugs-sockets
- Burner opening hinge
- Lifting rings
- IP 54 electric protection level

Standard equipment:

- 1 flange gasket
- 1 thermal screen
- screws for fixing the flange
- screws for fixing the burner flange to the boiler
- Seal control pressure switch (for installation on gas train)
- DN 80 gas supply connector for gas train connection (for RS 1000-1200)
- Instruction handbook for installation, use and maintenance
- Spare parts catalogue.

Modulating Gas Burners

RS 1000÷2000/E-/EV C01 SERIES

RIELLO

Available models

Burners

CODE	MODEL					HEAT OUTPUT		TOTAL ELECTRICAL POWER (kW)	CERTIFICATION	NOTE
						NATURAL GAS				
						(kW)	(Nm ³ /h)			
20062014	RS 1000/E C01	TC	FS1-FS2	3/400/50	230/50-60	1300/3800-10100	130/380-940	24	-	(1)
20061950	RS 1200/E C01	TC	FS1-FS2	3/400/50	230/50-60	1500/5500-11100	150/550-1150	27,2	-	(1)
20081191	RS 1300/E C01	TC	FS1/FS2	3/400/50	230/50-60	2500/7500÷13000	250/750÷1300	34,5	-	(1)
20080872	RS 1600/E C01	TC	FS1/FS2	3/400/50	230/50-60	3065/9503÷15560	307/951÷1556	41,5	-	(1)
20080867	RS 2000/E C01	TC	FS1/FS2	3/400/50	230/50-60	4000/12000÷19500	400/135÷1950	49,3	-	(1)
20110674	RS 2000/E C01	TL	FS1/FS2	3/400/50	230/50-60	4000/12000÷19500	400/135÷1950	49,3	-	(1)
20062128	RS 1000/EV C01	TC	FS1-FS2	3/400/50	230/50-60	1300/3800-10100	130/380-940	24	-	(1)
20062129	RS 1200/EV C01	TC	FS1-FS2	3/400/50	230/50-60	1500/5500-11100	150/550-1150	27	-	(1)
20081190	RS 1300/EV C01	TC	FS1/FS2	3/400/50	230/50-60	2500/7500÷13000	250/750÷1300	34,5	-	(1)
20080871	RS 1600/EV C01	TC	FS1/FS2	3/400/50	230/50-60	3065/9503÷15560	307/951÷1556	41,5	-	(1)
20070919	RS 2000/EV C01	TC	FS1/FS2	3/400/50	230/50-60	4000/12000÷19500	400/135÷1950	49,3	-	(1)

Natural gas, net calorific value: 10 kWh/Nm³ - Density: 0,71 kg/Nm³

(1) according to 2016/426/EU - 2014/35/EU - 2014/30/EU - 2006/42/EU - 2014/68/EU Directives

Gas Trains

Code	Gas train		Adapter Code
	Model	∅	
3970221*	MBC 1200/1 - RSM 60	Rp 2"	RS 1000 20066263 / (20065924 + 20066263) ¹
3970222*	MBC 1900/1 - FSM 40	DN 65	RS 1000 20066263 / (20065924 + 20066263) ¹
3970223*	MBC 3100/1 - FSM 40	DN 80	RS 1000 20066268 / (20065937 + 20066268) ¹
3970224*	MBC 5000/1 - FSM 80	DN 100	RS 1000 20066278 / (20065960 + 20066278) ¹
20044659*	CB 525/1 - RSM 30	Rp 2"	RS 1000 20066263 / (20065924 + 20066263) ¹ RS 1200 ●
3970147*	CB 5065/1 - FSM 30	DN 65	RS 1000 20066263 / (20065924 + 20066263) ¹
3970148*	CB 5080/1 - FSM 30	DN 80	RS 1000 20066268 / (20065937 + 20066268) ¹
3970149*	CB 50100/1 - FSM 30	DN 100	RS 1000 20066278 / (20065960 + 20066278) ¹
20015871*	CB 50125/1 - FSM 30	DN 125	RS 1000 20066284 / (20065968 + 20066284) ¹

Please see designation of Gas Train Series in the page before the Catalogue index.

* 230V/50Hz - 220V/60Hz electrical supply.

The valve seal control device is compulsory (conforming to EN 676) on gas trains to burners with a maximum output over 1200 kW.

The seal control function is managed by LMV control box, by installation on gas train of a pressure switch supplied, as standard equipment with the burner.

To select the gas train please refer to the technical data leaflet and/or instruction manual.

● Not available.

□ Additional adapter not necessary, the gas train may be connected directly to the burner.

1) To be used with gas train and burner opening on the left (fan motor side).

Modulating Gas Burners

RS 1000÷2000/E-/EV C01 SERIES

Available models

Gas Trains

Code	Gas train			CQ KIT Code	Adapter Code	
	Model	∅	◆		RS 1300	RS 1600 - 2000
3970223	MBC 3100/1 - FSM 40	DN 80	-	3010344	20130713	20130602
20093449	MBC 3100/1 CQ FSM 40	DN 80	CQ	-	20130713	20130602
3970224	MBC 5000/1 - FSM 80	DN 100	-	3010344	20130602	20130616
20093452	MBC 5000/1 CQ FSM 80	DN 100	CQ	-	20130602	20130616
3970149	CB 50100/1 - FSM 30	DN 100	-	3010344	20130602	20130616
20015871	CB 50125/1 - FSM 30	DN 125	-	3010344	20130606	20130617
20043047	DMV 50100/1 - FSM -0	DN 100	-	3010344	20130602	20130616
20043049	DMV 50100/1 CQ FSM -2	DN 100	CQ	-	20130602	20130616
20043050	DMV 50125/1 - FSM -0	DN 125	-	3010344	20130606	20130617
20043052	DMV 50125/1 CQ FSM -2	DN 125	CQ	-	20130606	20130617

Please see designation of Gas Train Series in the page before the Catalogue index.

- ◆ Gas valve leak detection control device:
- gas train not equipped with leak detection control device; this device can be ordered separately - see VPS column - and installed later.
CQ gas train with pressure switch for leak detection control of burners /E and /EV.
- CQ KIT Additional pressure switch for leak detection control in combination with burners /E and /EV.
- Gas train not available or not suitable for the matching to the burner.
- Additional adapter not necessary, the gas train may be connected directly to the burner.

Modulating Gas Burners

RS 1000÷2000/E-/EV C01 SERIES

RIELLO

Burner accessories

Variable Speed Drive (VSD) for RS/EV series only



The motor speed variation for the RS/EV C01 burners series is obtained thanks to a frequency converter: variable speed drive (VSD), provided with a programming panel with start-up assistant. It always must be ordered with RS/EV series.

BURNER	MAX POWER (kW)	KIT CODE
▶ RS 1000/EV C01	22	20163099
▶ RS 1200-1300/EV C01	30	20163100
▶ RS 1600/EV C01	37	20163105
▶ RS 2000/EV C01	45	On demand

Accessories for checking temperature and pressure



In RS 1000÷2000/E-/EV C01 models the PID regulator is integrated inside the LMV control box. The relative temperature or pressure probes fitted to the regulator must be chosen on the basis of the application.

BURNER	PROBE TYPE	RANGE (°C) (bar)	KIT CODE
▶ All models	Temperature PT 100	-100 ÷ 500°C	3010110
	Pressure 4 ÷ 20 mA	0 ÷ 2,5 bar	3010213
	Pressure 4 ÷ 20 mA	0 ÷ 16 bar	3010214

Display and Operating Unit (AZL) for RS/E models



This tool is needed for combustion system commissioning and monitoring. The AZL, Display and Operating Unit, is included in RS/EV and RS1000-1200/E-EV models.

BURNER	KIT CODE
▶ All models *	3010469

* for Russian language only

GAS

Modulating Gas Burners

RS 1000÷2000/E-/EV C01 SERIES

Burner accessories

Oxygen Control kit (QGO₂) for RS/EV series only



The QGO₂ is an oxygen analyzer with relevant probe which controls and supervises the residual oxygen content in exhaust gases.

BURNER	KIT CODE
► All models	3010378
	20045187*

* Installation outside the burner cover

Kit efficiency with oxygen control kit (for RS/EV only)



The kit includes two temperature sensors: one for air and one for exhaust gas detection. They must be wired to oxygen control kit interface to allow the LMV 52 efficiency calculation. The value is showed on AZL display.

BURNER	KIT CODE
► All models	3010377

PC Interface Software (ACS 450)



PC tool for convenient programming and burner settings, process visualization, data recording, selection of AZL language, software update AZL.

BURNER	KIT CODE
► All models	3010388

Sound proofing box

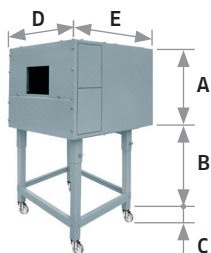

If noise emission needs reducing even further, sound-proofing boxes are available. When a lower "B" dimension is required, it is available the Box Support Kit code 20065135 which allows to reduce it at the fixed dimension of 55 mm. The sound-proofing boxes are not suitable for outdoor use.

BURNER	BOX TYPE	A (mm)	B (mm) min-max	C (mm)	D (mm)	E (mm)	[dB(A)] (*)	BOX CODE
► RS 1000-1200/E-EV C01	C8	1425	285 - 1000	110	1500	1800	10	3010401
► RS 1300-1600-2000/E-EV C01	C9							20108736

(*) Average noise reduction according to EN 15036-1 standard

Gas train accessories

Adapters

In certain cases, an adapter must be fitted between the gas train and the burner, when the diameter of the gas train is different from the set diameter of the burner. Below are given the available adapters; please see on the Gas Train list the correct adapter codes to select.

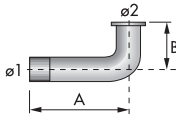
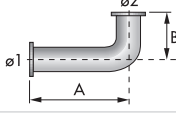
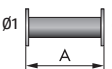
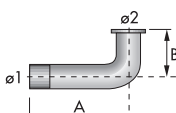
ADAPTER	DIMENSIONS				ADAPTER CODE
	Ø1 DN	Ø2 DN	A mm	B mm	
	2"	65 / 80	780	230	20068058
	2"	65 / 80	230	375	20066253
	65	65 / 80	230	375	20066263
	80	65 / 80	230	375	20066268
	100	65 / 80	230	375	20066278
	125	65 / 80	245	375	20066284
	65	65	800	-	20065924
	80	80	800	-	20065937
	100	100	800	-	20065960
	125	125	800	-	20065968
	100	100	320	174	3090680
	100	100	350	350	20130616
	125	100	350	350	20130617
	150	100	320	320	20130039
	100	80	350	350	20130602
	125	80	350	350	20130606
	80	80	350	350	20130713

Gas train accessories

Stabiliser spring



To vary the pressure range of the gas train stabilisers, accessory springs are available. The following table shows these accessories with their application range. Please refer to the technical manual for the correct choice of spring.

GAS TRAIN	SPRING COLOUR	SPRING PRESSURE RANGE mbar	SPRING CODE
▶ MBC 1900/1 - 3100/1 MBC 5000/1	White	4 - 20	3010381
	Red	20 - 40	3010382
	Black	40 - 80	3010383
	Green	80 - 150	3010384
▶ CB 5065/1 - 5080/1	Red	25 - 55	3010133
	Black	60 - 110	3010135
	Pink	100 - 150	3090456
	Grey	140 - 200	3090992
▶ CB 50100/1	Red	25 - 55	3010134
	Black	60 - 110	3010136
	Pink	100 - 150	3090489
▶ CB 50125/1	Grey	140 - 200	3092174
	Red	25 - 55	3010315
	Yellow	30 - 70	3010316
	Black	60 - 110	3010317
	Pink	100 - 150	3010318

PVP (Pressure Valve Proving) kit

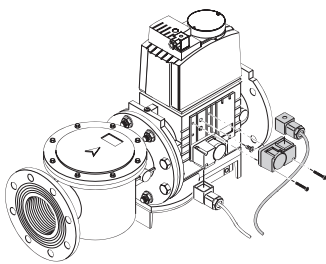

The seal control function is included on Burner Digital Management System, it is only necessary to add the PVP kit on the gas train.

The PVP is included as standard equipment on RS RS1300-1600-2000 models.

BURNER	KIT CODE
▶ MB - CB - MBC type	3010344

GAS SERIES

The GAS series of burners cover a firing range from 130 to 1050 kW.

Operation is "one stage"; the combustion head, that can be set on the basis of required output, allows optimal performance ensuring good combustion and reducing fuel consumption.

The GAS series are extremely reliable burners, featured by a simple use and an operation without particular maintenance intervention.

Simplified maintenance is achieved by the slide bar system, which allows easy access to all of the essential components of the combustion head. All electrical components are easily accessible only by dismounting a protection panel, thus guaranteeing a quick and simple intervention on components.

Guidelines for installation of burners in conformity to EU Regulation:

A RIELLO burner (Heat Generator), where it is matched with a water-based boiler (Heater Housing) with a nominal output ≤ 400 kW, providing heat for heating purposes and heat to deliver sanitary hot water, can be installed:

- With boilers (heater housings) already in service in the field, for replacement of identical products, in conformity to Article 1, paragraph 2, point (G) of the EU Regulation No. 813/2013;
- With boilers (heater housings) on a new installation.

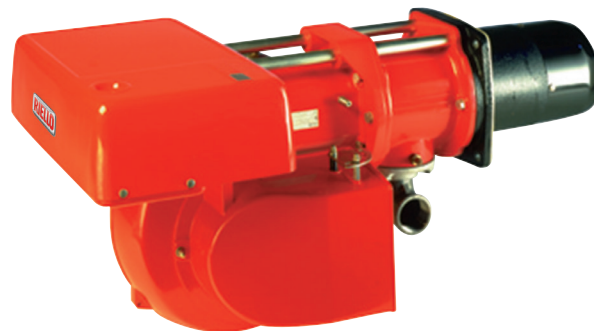

GAS 3	130 ÷ 350 kW
GAS 4	185 ÷ 465 kW
GAS 5	325 ÷ 660 kW
GAS 6	525 ÷ 1050 kW

FIRING RATES

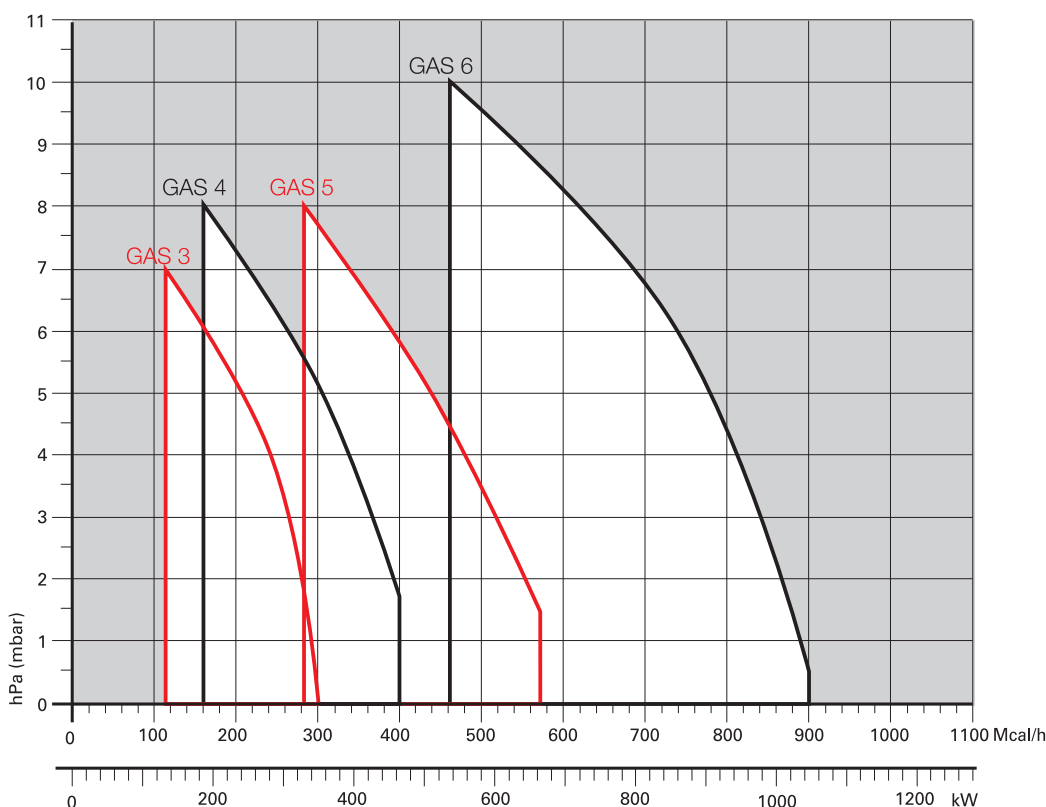

Useful working field for choosing the burner

Test conditions conforming to EN676
 Temperature: 20°C
 Pressure: 1013,5 mbar
 Altitude: 0 m a.s.l.

One Stage Gas Burners

GAS SERIES

Overall dimensions (mm)

BURNER

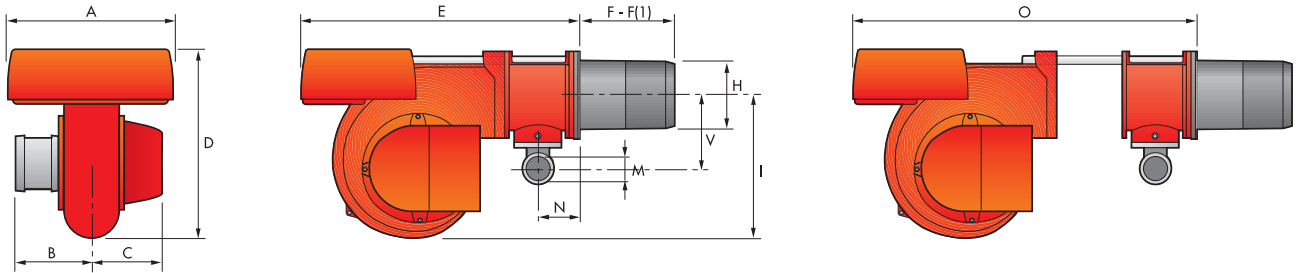

MODEL	A	B	C	D	E	F - F (1)	H	I	M	N	O	V
▶ GAS 3	410	205	205	397	610	185 - 320	140	292	1"1/2	97	775	165
▶ GAS 4	410	205	205	397	610	187 - 320	150	292	1"1/2	97	775	165
▶ GAS 5	431	226	205	437	645	207 - 365	155	332	1"1/2	97	810	165
▶ GAS 6	463	258	205	485	770	227 - 360	175	370	2"	131	966	195

(1) Length with extended combustion head

BURNER - BOILER MOUNTING FLANGE

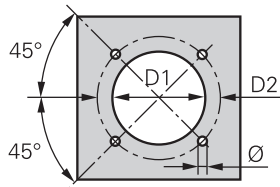

MODEL	D1	D2	Ø
▶ GAS 3	155	226	M10
▶ GAS 4	165	226	M10
▶ GAS 5	165	226	M10
▶ GAS 6	185	276	M12

PACKAGING

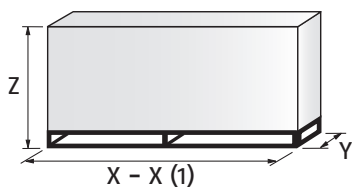

MODEL	X - X (1)	Y	Z	kg
▶ GAS 3	850	545	473	32
▶ GAS 4	850	545	473	38
▶ GAS 5	895	543	520	41
▶ GAS 6	1045	543	555	58

(1) Length with extended combustion head

Specification

DESIGNATION OF SERIES

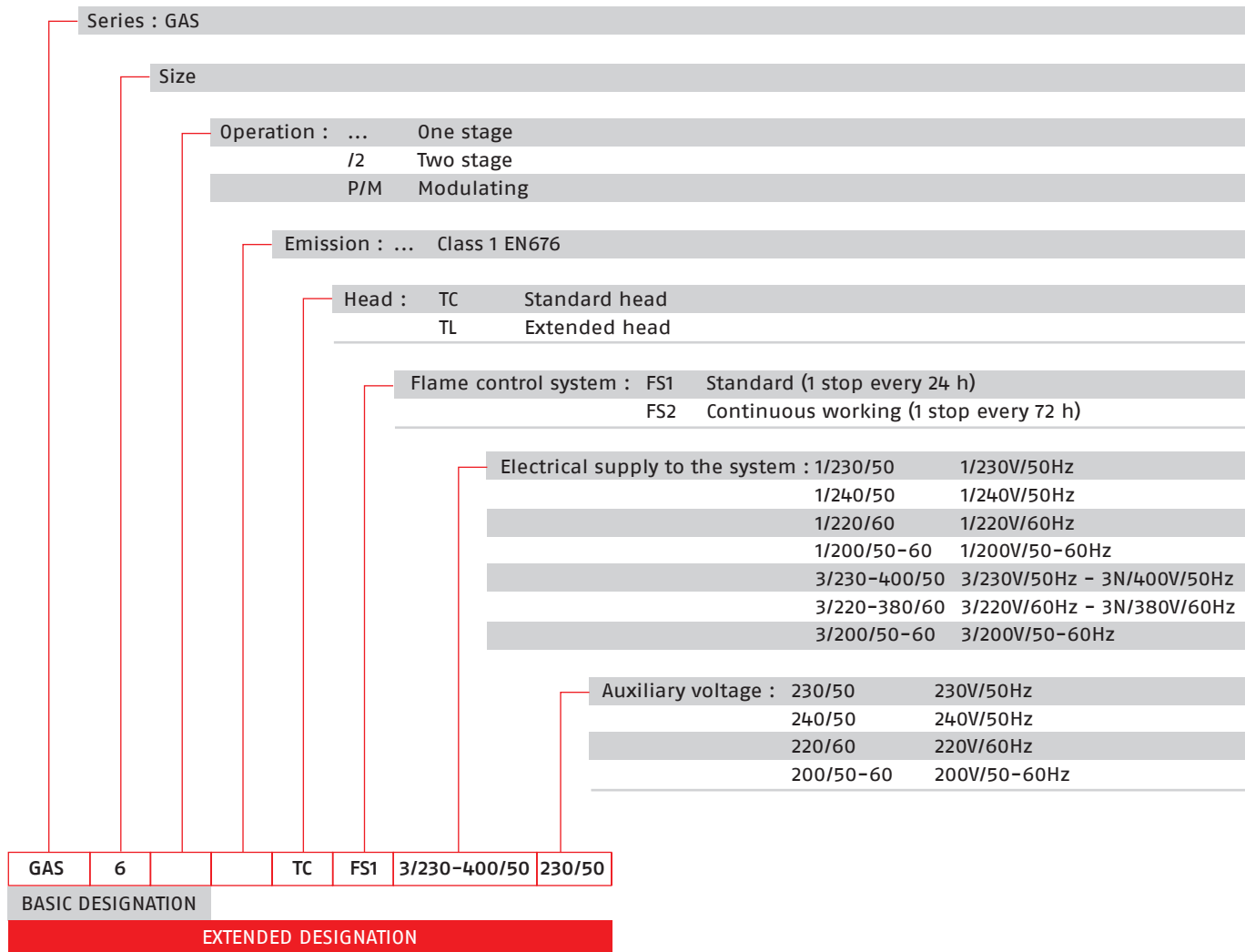

One Stage Gas Burners

GAS SERIES

Specification

STATE OF SUPPLY

Monoblock forced draught gas burner, one stage operation, made up of:

- Air suction circuit
- Fan with forward curved blades
- Air damper for air setting
- Combustion head, that can be set on the basis of required output, fitted with:
 - stainless steel end cone, resistant to corrosion and high temperatures
 - ignition electrodes
 - flame stability disk
- Minimum air pressure switch
- Single phase or three phases electrical motor
- Microprocessor-based burner safety control box, with diagnostic function
- Flame inspection window
- Slide bars for easier installation and maintenance
- Protection filter against radio interference
- IP X0D (IP 40) protection level.

Standard equipment:

- 1 gas train gasket
- 1 flange gasket
- 4 screws for fixing the flange
- 1 thermal screen
- 4 screws for fixing the burner flange to the boiler
- Instruction handbook for installation, use and maintenance
- Spare parts catalogue

Available models

Burners

CODE	MODEL					HEAT OUTPUT		TOTAL ELECTRICAL POWER (kW)	CERTIFICATION	NOTE
						NATURAL GAS (kW)	(Nm ³ /h)			
3751987	GAS 3	TC	FS1	1/200/50-60	200/50-60	130-350	13-35	0,48-0,6	-	
3751982	GAS 3	TC	FS1	1/220/60	220/60	130-350	13-34	0,4	-	
3751918	GAS 3	TC	FS1	1/230/50	230/50	130-350	13-35	0,4	CE 0085AQ0707	
3751960	GAS 3	TC	FS1	1/240/50	240/50	130-350	13-35	0,4	-	
3751961	GAS 3	TL	FS1	1/240/50	240/50	130-350	13-36	0,4	-	
3751617	GAS 4	TC	FS1	1/230/50	230/50	185-465	18,5-46,5	0,54	-	
3751687	GAS 4	TC	FS1	3/200/50-60	200/50-60	180-470	18-47	0,6	-	
3751682	GAS 4	TC	FS1	3/220-380/60	220/60	180-470	18-47	0,6	-	
3751787	GAS 5	TC	FS1	3/200/50-60	200/50-60	320-660	32-66	0,85	-	
3751782	GAS 5	TC	FS1	3/220-380/60	220/60	320-660	32-66	1,1	-	
3751717	GAS 5	TC	FS1	3/230-400/50	230/50	325-660	32,5-66	0,85	-	
3751882	GAS 6	TC	FS1	3/220-380/60	220/60	525-1050	52-105	1,7	-	
3751817	GAS 6	TC	FS1	3/230-400/50	230/50	525-1050	52,5-105	1,7	-	

Natural gas G20 net calorific value: 10 kWh/Nm³ - Density gas G20: 0,71 kg/Nm³

The burners of GAS series are in according to 2016/426/EU - 2014/30/EU - 2014/35/EU - 2006/42 CE Directive and EN 676 Norm.

Available models

Gas Trains

CODE	GAS TRAIN			VPS CODE	ADAPTER CODE			
	MODEL	Ø	C.T.		GAS 3	GAS 4	GAS 5	GAS 6
3970500*	MB 405/1 - RT 20	Rp 3/4"	-	3010123	3000824		●	●
3970084*	MB 405/2 - RSD 20	Rp 1/2"	-	3010123	20044756		●	●
3970553*	MB 407/1 - RT 20	Rp 3/4"	-	3010123	3000824		●	●
3970599*	MB 407/1 - RT 52	Rp 3/4"	-	3010123			●	●
3970229*	MB 407/1 - RSM 20	Rp 3/4"	-	3010123			●	●
3970537*	MB 407/2 - RSD 20	Rp 3/4"	-	3010123			●	●
3970556*	MB 407/2 - RT 20	Rp 3/4"	-	3010123			●	●
3970258*	MB 410/1 - RT 52	Rp 1" 1/2	-	3010123			□	□
3970554*	MB 410/1 - RT 20	Rp 3/4"	-	3010123	3000824		3000824+	3000843
3970600*	MB 410/1 - RT 52	Rp 3/4"	-	3010123				
3970230*	MB 410/1 - RSM 20	Rp 3/4"	-	3010123				
3970534*	MB 410/2 - RSD 20	Rp 3/4"	-	3010123				
3970557*	MB 410/2 - RT 20	Rp 3/4"	-	3010123				
3970256*	MB 412/1 - RT 52	Rp 1" 1/2	-	3010123				
3970144*	MB 412/1 - RT 20	Rp 1" 1/2	-	3010123	□	□	□	
3970197**	MB 412/1 CT RT 20	Rp 1" 1/2	◆	-	□	□	□	
3970231*	MB 412/1 - RSM 20	Rp 1" 1/2	-	3010123	□	□	□	
3970152*	MB 412/2 - RT 20	Rp 1" 1/2	-	3010123	□	□	□	
3970180*	MB 415/1 - RT 30	Rp 1" 1/2	-	3010123	□	□	□	
3970198**	MB 415/1 CT RT 30	Rp 1" 1/2	◆	-	□	□	□	
3970250*	MB 415/1 - RT 52	Rp 1" 1/2	-	3010123	□	□	□	
3970253**	MB 415/1 CT RT 52	Rp 1" 1/2	◆	-	□	□	□	
3970232*	MB 415/1 - RSM 30	Rp 1" 1/2	-	3010123	□	□	□	
3970183*	MB 415/2 - RT 20	Rp 1" 1/2	-	3010123	□	□	□	3000822
3970181*	MB 420/1 - RT 30	Rp 2"	-	3010123	□	□	□	
3970182**	MB 420/1 CT RT 30	Rp 2"	◆	-	□	□	□	
3970257*	MB 420/1 - RT 52	Rp 2"	-	3010123	□	□	□	
3970252**	MB 420/1 CT RT 52	Rp 2"	◆	-	□	□	□	
3970233*	MB 420/1 - RSM 30	Rp 2"	-	3010123	□	□	□	
3970234**	MB 420/1 CT RSM 30	Rp 2"	◆	-	□	□	□	
3970184*	MB 420/2 - RT 20	Rp 2"	-	3010123	□	□	□	
3970185**	MB 420/2 CT RT 20	Rp 2"	◆	-	□	□	□	
3970221*	MBC 1200/1 - RSM 60	Rp 2"	-	3010123	□	□	□	
3970225**	MBC 1200/1 CT RSM 60	Rp 2"	◆	-	□	□	□	
3970222*	MBC 1900/1 - FSM 40	DN 65	-	3010123	●	●	3000825	
3970226**	MBC 1900/1 CT FSM 40	DN 65	◆	-	●	●	3000826	
3970223*	MBC 3100/1 - FSM 40	DN 80	-	3010123	●	●	●	3000826
3970227**	MBC 3100/1 CT FSM 40	DN 80	◆	-	●	●	●	
3970224*	MBC 5000/1 - FSM 80	DN 100	-	3010123	●	●	●	●
3970228**	MBC 5000/1 CT FSM 80	DN 100	◆	-	●	●	●	●

Please see designation of Gas Train Series in the page before the Catalogue index.

* 230V/50Hz - 220V/60Hz electrical supply.

** 230V/50Hz electrical supply.

The valve seal control device is compulsory (conforming to EN 676) on gas trains to burners with a maximum output over 1200 kW.

To select the gas train please refer to the technical data leaflet and/or instruction manual.

C.T. Gas valve leak detection control device:

- gas train not equipped with leak detection control device; this device can be ordered separately - see VPS column - and installed later.

◆ gas train equipped with leak detection control device.

VPS Valve leak detection control device. Supplied separately from the gas train (please see Gas train accessories paragraph for both 50 Hz and 60 Hz codes).

● Not available.

□ Additional adapter not necessary, the gas train may be connected directly to the burner.

One Stage Gas Burners

GAS SERIES

Available models

Gas Trains

CODE	GAS TRAIN			VPS CODE	ADAPTER CODE			
	MODEL	Ø	C.T.		GAS 3	GAS 4	GAS 5	GAS 6
3970145*	CB 512/1 - RSM 30	Rp 1" 1/2	-	3010123	□	□	□	3000843
20045589**	CB 512/1 CT RSM 30	Rp 1" 1/2	◆	-	□	□	□	
3970153*	CB 512/2 - RT 32	Rp 1" 1/2	-	3010123	□	□	□	
3970146*	CB 520/1 - RSM 30	Rp 2"	-	3010123	3000822			□
3970160**	CB 520/1 CT RSM 30	Rp 2"	◆	-				□
3970154*	CB 520/2 - RT 32	Rp 2"	-	3010123				□
20044659*	CB 525/1 - RSM 30	Rp 2"	-	3010123				□
20044660**	CB 525/1 CT RSM 30	Rp 2"	◆	-				□
3970147*	CB 5065/1 - FSM 30	DN 65	-	3010123				●
3970161**	CB 5065/1 CT FSM 30	DN 65	◆	-	●			
3970155*	CB 5065/2 - FT 32	DN 65	-	3010123	●			
3970167**	CB 5065/2 CT FT 32	DN 65	◆	-	●			
3970148*	CB 5080/1 - FSM 30	DN 80	-	3010123	●	●	3000826+ 3000822	3000826
3970162**	CB 5080/1 CT FSM 30	DN 80	◆	-	●	●		
3970156*	CB 5080/2 - FT 32	DN 80	-	3010123	●	●		
3970168*	CB 5080/2 CT FT 32	DN 80	◆	-	●	●	3010370+ 3000826	
3970149*	CB 50100/1 - FSM 30	DN 100	-	3010123	●	●		●
3970163**	CB 50100/1 CT FSM 30	DN 100	◆	-	●	●		●
20015871*	CB 50125/1 - FSM 30	DN 125	-	3010123	●	●	●	●
3970196**	CB 50125/1 CT FSM 30	DN 125	◆	-	●	●	●	●

Please see designation of Gas Train Series in the page before the Catalogue index.

* 230V/50Hz -220V/60Hz electrical supply.

** 230V/50Hz electrical supply.

The valve seal control device is compulsory (conforming to EN 676) on gas trains to burners with a maximum output over 1200 kW.

To select the gas train please refer to the technical data leaflet and/or instruction manual.

C.T. Gas valve leak detection control device:

- gas train not equipped with leak detection control device; this device can be ordered separately - see VPS column - and installed later.

◆ gas train equipped with leak detection control device.

VPS Valve leak detection control device. Supplied separately from the gas train (please see Gas train accessories paragraph for both 50 Hz and 60 Hz codes).

● Not available.

□ Additional adapter not necessary, the gas train may be connected directly to the burner.

Burner accessories

Extended head kit

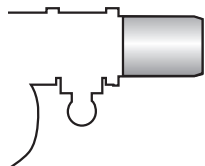

"Standard head" burners can be transformed into "extended head" versions, by using the special kit.

BURNER	STANDARD HEAD LENGTH (mm)	EXTENDED HEAD LENGTH (mm)	KIT CODE
▶ GAS 3	185	320	3000605
▶ GAS 4	187	320	3000606
▶ GAS 5	207	365	3000607
▶ GAS 6	227	360	3000608

Spacer kit

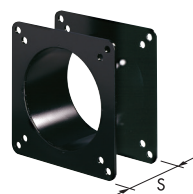

If burner head penetration into the combustion chamber needs reducing, varying thickness spacers are available, as given in the following list.

BURNER	SPACER THICKNESS S (mm)	KIT CODE
▶ GAS 3 - 4 - 5 - 6	142	3000755

Continuous ventilation kit



If the burner requires continuous ventilation in the stages without flame, a special kit is available as given in the following table.

BURNER	KIT CODE
▶ GAS 3 - 4 - 5 - 6	3010030

Post-ventilation kit

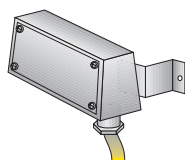

To prolong ventilation for approximately 5 seconds after opening of thermostats chain, a special kit is available.

BURNER	KIT CODE
▶ GAS 3 - 4 - 5 - 6	3010004

Sound proofing box

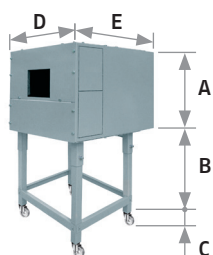

If noise emission needs reducing even further, sound-proofing boxes are available. When a lower "B" dimension is required, it is available the Box Support Kit code 20065135 which allows to reduce it at the fixed dimension of 55 mm. The sound-proofing boxes are not suitable for outdoor use.

BURNER	BOX TYPE	A (mm)	B (mm) min-max	C (mm)	D (mm)	E (mm)	[dB(A)] (*)	BOX CODE
▶ GAS 3 - 4 - 5 - 6	C1/3	650	372 - 980	110	690	770	10	3010403

(*) Average noise reduction according to EN 15036-1 standard

One Stage Gas Burners

GAS SERIES

Burner accessories

LPG kit

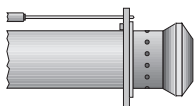

For burning LPG gas, a special kit is available.

BURNER	KIT CODE FOR STANDARD HEAD (*)	KIT CODE FOR EXTENDED HEAD (*)
▶ GAS 3	3000657	3000807
▶ GAS 4	3000658	3000808
▶ GAS 5	3000659	3000809
▶ GAS 6	3000753	3000810

(*) without CE certification

Town Gas kit

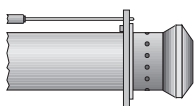

For burning Town Gas, a special kit is available.

BURNER	KIT CODE FOR STANDARD HEAD (*)	KIT CODE FOR EXTENDED HEAD(*)
▶ GAS 3	3000742	-
▶ GAS 4	3000754	-
▶ GAS 5	3000759	-
▶ GAS 6	3000768	-

(*) Without CE certification

PC Interface kit



To connect the RMG control box to a personal computer for the transmission of operation, fault signals and detailed service information, an interface adapter with PC software are available.

BURNER	KIT CODE
▶ GAS 3 - 4 - 5 - 6	3002719

Protection kit (electromagnetic interferences)









When the burner is installed in a room particularly subject to electromagnetic interference (signals emitted over 10 V/m) due for example to INVERTER presence or in systems where the lengths of the thermostat connections is over 20 meters, this specific protection kit is available as an interface between the thermostatic controls and the burner.

BURNER	KIT CODE
▶ All models	3010386

Gas train accessories

Adapters

In certain cases, an adapter must be fitted between the gas train and the burner, when the diameter of the gas train is different from the set diameter of the burner. Below are given the available adapters; please see on the Gas Train list the correct adapter codes to select.

ADAPTER	LENGTH mm	ADAPTER CODE
2"  1" 1/2	70	3000822
3/4"  1" 1/2	31	3000824
DN 65  2" 1/2 	300	3000825
DN 80  2" 1/2 	300	3000826
1" 1/2  2"	35	3000843
1/2"  1" 1/2	31	20044756

Seal control kit



To test the valve seals on the gas train, a special "seal control kit" is available.

BURNER	GAS TRAIN	KIT CODE for 50 Hz operation	KIT CODE for 60 Hz operation
▶ GAS 3	MB 407/2 - 410/2 - 412/2 - 415/2	3010123	20168805
	CB 512/2	3010125	20169320
▶ GAS 4	MB 410/2 - 412/2 - 415/2 - 420/2	3010123	20168805
	CB 512/2 - 520/2	3010125	20169320
▶ GAS 5	MB 410/2 - 412/2 - 415/2 - 420/2	3010123	20168805
	CB 512/2 - 520/2	3010125	20169320
▶ GAS 6	MB 410/2 - 412/2 - 415/2 - 420/2	3010123	20168805
	CB 512/2 - 520/2 - 5065/2	3010125	20169320

Stabiliser spring



Accessory springs are available to vary the pressure range of the gas train stabilisers.

GAS TRAIN	SPRING COLOUR	SPRING PRESSURE RANGE mbar	SPRING CODE
▶ CB 512/2	Red	25 - 55	3010131
	Black	60 - 110	3010157
	Pink	90 - 150	3090486
▶ CB 520/2	Red	25 - 55	3010132
	Black	60 - 110	3010158
	Pink	100 - 150	3090487
▶ CB 5065/2 - 5080/2	Red	25 - 55	3010133
	Black	60 - 110	3010135
	Pink	100 - 150	3090456
	Grey	140 - 200	3090992



We are here

setting the standard as your
specialist energy-partner



GAS/2 SERIES

The GAS/2 series of burners covers a firing range from 130 to 3200 kW and they have been designed for use in civil installations of average dimensions, like building areas and large apartment groups or for use in industrial applications, like small or medium plants.

Operation is two stage; the combustion head, that can be set on the basis of required output, allows optimal performance ensuring good combustion and reducing fuel consumption.

The main feature of these burners is their reliability due to a simple and strong construction, which permits operation without particular maintenance intervention.

Simplified maintenance is achieved by the slide bar system, which allows easy access to all of the essential components of the combustion head. All electrical components are easily accessible only by dismounting a protection panel, thus guaranteeing a quick and simple intervention on components.

Guidelines for installation of burners in conformity to EU Regulation:

A RIELLO burner (Heat Generator), where it is matched with a water-based boiler (Heater Housing) with a nominal output ≤ 400 kW, providing heat for heating purposes and heat to deliver sanitary hot water, can be installed:

- With boilers (heater housings) already in service in the field, for replacement of identical products, in conformity to Article 1, paragraph 2, point (G) of the EU Regulation No. 813/2013;
- With boilers (heater housings) on a new installation.

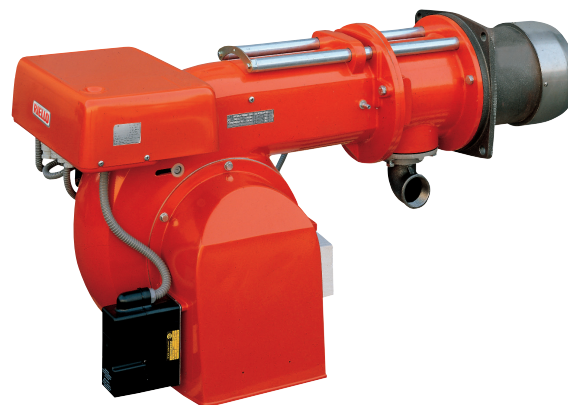

GAS 3/2	80/130 ÷	350 kW
GAS 4/2	120/180 ÷	470 kW
GAS 5/2	155/320 ÷	660 kW
GAS 6/2	300/520 ÷	1050 kW
GAS 7/2	400/800 ÷	1760 kW
GAS 9/2	1000/1750 ÷	3200 kW

FIRING RATES

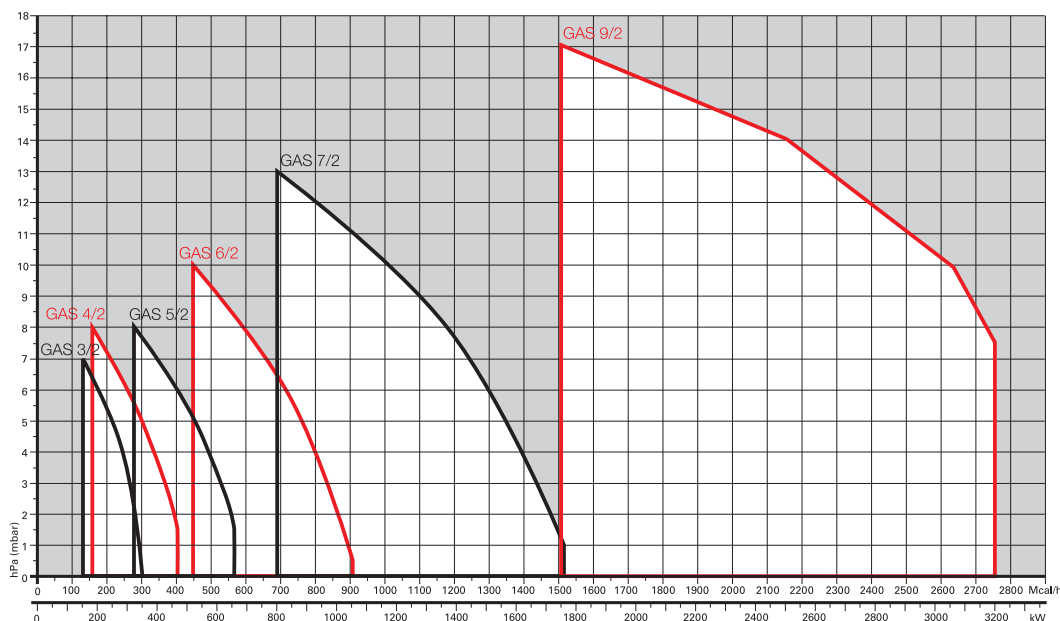

Useful working field for choosing the burner

Test conditions conforming to EN676
 Temperature: 20°C
 Pressure: 1013,5 mbar
 Altitude: 0 m a.s.l.

Two Stage Gas Burners

GAS/2 SERIES

Overall dimensions (mm)

BURNER

GAS 3/2 - 4/2 - 5/2 - 6/2 - 7/2

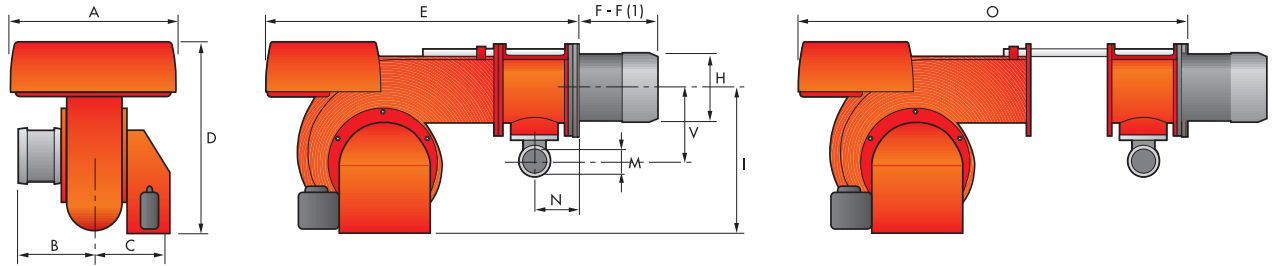

GAS 9/2

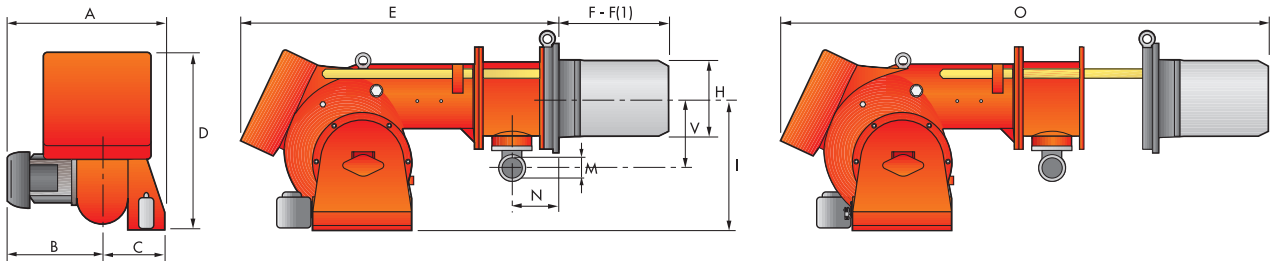

MODEL	A	B	C	D	E	F - F (1)	H	I	M	N	O	V
▶ GAS 3/2	410	205	205	397	610	185 - 320	140	292	1 1/2"	97	775	165
▶ GAS 4/2	410	205	205	397	610	187 - 320	150	292	1 1/2"	97	775	165
▶ GAS 5/2	431	226	205	437	645	207 - 365	155	332	1 1/2"	97	810	165
▶ GAS 6/2	463	258	205	485	770	227 - 360	175	370	2"	131	966	195
▶ GAS 7/2	606	358	248	590	920	240 - 400	220	445	2"	140	1142	245
▶ GAS 9/2	780	445	335	680	1200	444 - 574	295	495	2"	168	1627	210

(1) Length with extended combustion head

BURNER - BOILER MOUNTING FLANGE

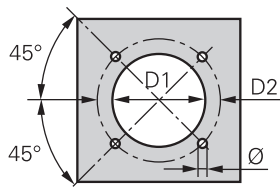

MODEL	D1	D2	Ø
▶ GAS 3/2	155	226	M10
▶ GAS 4/2	165	226	M10
▶ GAS 5/2	165	226	M10
▶ GAS 6/2	185	276	M12
▶ GAS 7/2	230	325	M12
▶ GAS 9/2	300	368	M18

PACKAGING

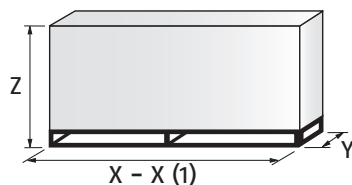

MODEL	X - X (1)	Y	Z	kg
▶ GAS 3/2	850	545	473	34
▶ GAS 4/2	850	545	473	40
▶ GAS 5/2	895	543	520	43
▶ GAS 6/2	1045	543	555	60
▶ GAS 7/2	1400	850	650	98
▶ GAS 9/2	1870	920	910	240

(1) Length with extended combustion head

Specification

DESIGNATION OF SERIES

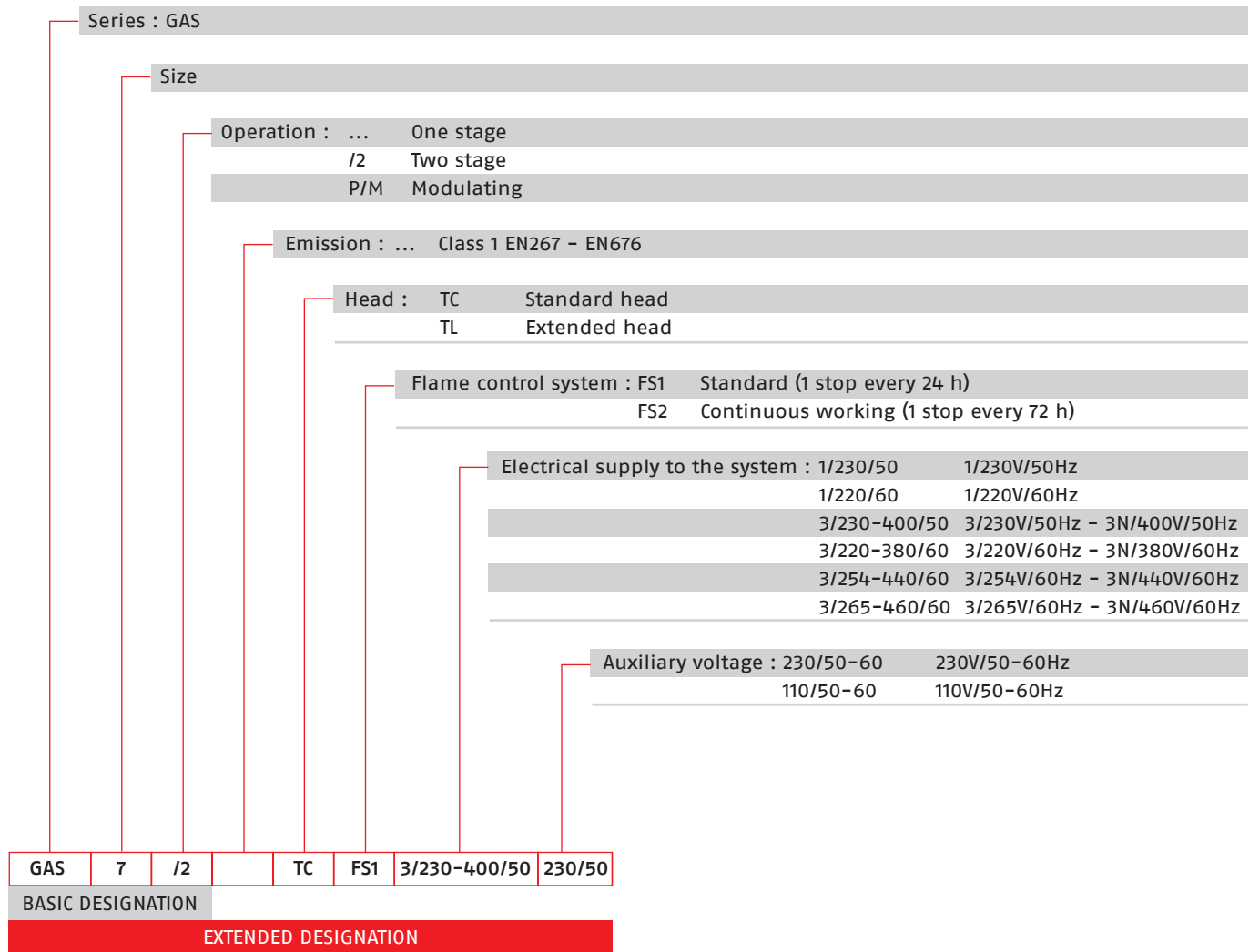

Two Stage Gas Burners

GAS/2 SERIES

Specification

STATE OF SUPPLY

Monoblock forced draught gas burner, two stage operation, made up of:

- Air suction circuit
- Fan with forward curved blades
- Air damper for air setting
- Combustion head, that can be set on the basis of required output, fitted with:
 - stainless steel end cone, resistant to corrosion and high temperatures
 - ignition electrodes
 - flame stability disk
- Minimum air pressure switch
- Single phase or three phases electrical motor
- Microprocessor-based burner safety control box, with diagnostic function
- Flame inspection window
- Slide bars for easier installation and maintenance
- Protection filter against radio interference
- IP X0D (IP 40) protection level.

Standard equipment:

- 1 gas train flange
- 1 flange gasket
- 1 insulating screen
- 8 screws for fixing the burner flange to the boiler
- Instruction handbook for installation, use and maintenance
- Spare parts catalogue.

Available models

Burners

CODE	MODEL	HEAT OUTPUT		TOTAL ELECTRICAL POWER (kW)	CERTIFICATION	NOTE
		NATURAL GAS (kW)	(Nm ³ /h)			
3752182	GAS 3/2 TC FS1 1/220/60 220/60	80/130-340	8/13-34	0,4	-	
3752118	GAS 3/2 TC FS1 1/230/50 230/50	80/130-350	8/13-35	0,4	CE 0085AQ0707	
3752218	GAS 4/2 TC FS1 1/230/50 230/50	120/180-470	12/18-47	0,54	CE 0085AQ0707	
3752282	GAS 4/2 TC FS1 3/220-380/60 220/60	115/180-470	11,5/18-47	0,6	-	
3752382	GAS 5/2 TC FS1 3/220-380/60 220/60	155/320-660	15,5/32-66	1,1	-	
3752318	GAS 5/2 TC FS1 3/230-400/50 230/50	155/320-660	15,5/32-66	0,85	CE 0085AQ0707	
3752482	GAS 6/2 TC FS1 3/220-380/60 220/60	300/520-1050	30/52-105	1,9	-	
3752418	GAS 6/2 TC FS1 3/230-400/50 230/50	300/520-1050	30/52-105	1,7	CE 0085AQ0707	
3752582	GAS 7/2 TC FS1 3/220-380/60 220/60	400/800-1760	40/80-176	3,8	-	
3752518	GAS 7/2 TC FS1 3/230-400/50 230/50	400/800-1760	40/80-176	3,4	CE 0085AQ0707	
20014057	GAS 9/2 TC FS1 3/400/50	1000/1750-3200	100/175-320	9	-	(1)

(1) For the 3/230/50 version use the 220 - 230 V conversion kit (see the burner accessories paragraph)

Natural gas G20 net calorific value: 10 kWh/Nm³ - Density gas G20: 0,71 kg/Nm³

The burners of GAS/2 series are in according to 2016/426/EU - 2014/30/EU - 2014/35/EU - 2006/42 CE Directive and EN 676 Norm.

Available models

Gas Trains

CODE	GAS TRAIN			VPS CODE	ADAPTER CODE					
	MODEL	∅	C.T.		GAS 3/2	GAS 4/2	GAS 5/2	GAS 6/2	GAS 7/2	GAS 9/2
3970084*	MB 405/2 - RSD 20	Rp 1/2"	-	3010123	20044756		●	●	●	●
3970537*	MB 407/2 - RSD 20	Rp 3/4"	-	3010123	3000824					
3970556*	MB 407/2 - RT 20	Rp 3/4"	-	3010123						
3970534*	MB 410/2 - RSD 20	Rp 3/4"	-	3010123						
3970557*	MB 410/2 - RT 20	Rp 3/4"	-	3010123						
3970152*	MB 412/2 - RT 20	Rp 1" 1/2	-	3010123	□	□	□	3000843		●
3970183*	MB 415/2 - RT 20	Rp 1" 1/2	-	3010123	□	□	□	3000843		●
3970184*	MB 420/2 - RT 20	Rp 2"	-	3010123	3000822					
3970185**	MB 420/2 CT RT 20	Rp 2"	◆	-						
3970153*	CB 512/2 - RT 32	Rp 1" 1/2	-	3010125	□	□	□	3000843		
3970154*	CB 520/2 - RT 32	Rp 2"	-	3010125	3000822					
3970155*	CB 5065/2 - FT 32	DN 65	-	3010123	●	3000825				
3970167**	CB 5065/2 CT FT 32	DN 65	◆	-	●	3000825				
3970156*	CB 5080/2 - FT 32	DN 80	-	3010123	●	●	3000826+	3000826		
3970168*	CB 5080/2 CT FT 32	DN 80	◆	-	●	●	3000822	3000826		
3809901	CBF 65/2	DN 65	-	-	●	●	●	●	●	●
3809902	CBF 80/2	DN 80	-	-	●	●	●	●	●	●

Please see designation of Gas Train Series in the page before the Catalogue index.

* 230V/50Hz -220V/60Hz electrical supply.

** 230V/50Hz electrical supply.

The valve seal control device is compulsory (conforming to EN 676) on gas trains to burners with a maximum output over 1200 kW.

To select the gas train please refer to the technical data leaflet and/or instruction manual.

C.T. Gas valve leak detection control device:

- gas train not equipped with leak detection control device; this device can be ordered separately - see VPS column - and installed later.

◆ gas train equipped with leak detection control device.

VPS Valve leak detection control device. Supplied separately from the gas train (please see Gas train accessories paragraph for both 50 Hz and 60 Hz codes).

● Not available.

□ Additional adapter not necessary, the gas train may be connected directly to the burner.

Two Stage Gas Burners

GAS/2 SERIES

Burner accessories

Extended head kit

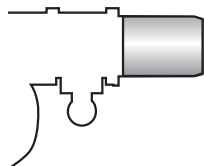

"Standard head" burners can be transformed into "extended head" versions, by using the special kit.

BURNER	STANDARD HEAD LENGTH (mm)	EXTENDED HEAD LENGTH (mm)	KIT CODE
▶ GAS 3/2	185	320	3000605
▶ GAS 4/2	187	320	3000606
▶ GAS 5/2	207	365	3000607
▶ GAS 6/2	227	360	3000608
▶ GAS 7/2	240	400	3000678

Spacer kit

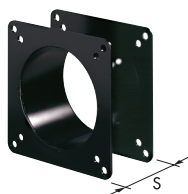

If burner head penetration into the combustion chamber needs reducing, varying thickness spacers are available, as given in the following list.

BURNER	SPACER THICKNESS S (mm)	KIT CODE
▶ GAS 3/2 - 4/2 - 5/2 - 6/2	142	3000755
▶ GAS 7/2	102	3000722
▶ GAS 9/2	122	3000723

Continuous ventilation kit



If the burner requires continuous ventilation in the stages without flame, a special kit is available as given in the following table.

BURNER	KIT CODE
▶ GAS 3/2 - 4/2 - 5/2 - 6/2 - 7/2 - 9/2	3010030

Post-ventilation kit

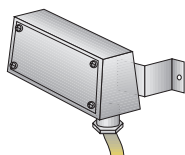

To prolong ventilation for approximately 5 seconds after opening of thermostats chain, a special kit is available.

BURNER	KIT CODE
▶ GAS 3/2 - 4/2 - 5/2 - 6/2 - 7/2 - 9/2	3010004

Burner accessories

Sound proofing box

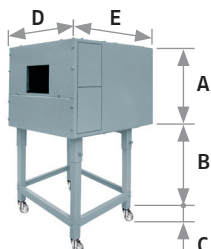

If noise emission needs reducing even further, sound-proofing boxes are available. When a lower "B" dimension is required, it is available the Box Support Kit code 20065135 which allows to reduce it at the fixed dimension of 55 mm. The sound-proofing boxes are not suitable for outdoor use.

BURNER	BOX TYPE	A (mm)	B (mm) min-max	C (mm)	D (mm)	E (mm)	[dB(A)] (*)	BOX CODE
▶ GAS 3/2 - 4/2 ▶ GAS 5/2 - 6/2	C1/3	650	372 - 980	110	690	770	10	3010403
▶ GAS 7/2	C4/5	850	160 - 980	110	980	930	10	3010404
▶ GAS 9/2	C7	1255	160 - 980	110	1140	1345	10	3010376

(*) Average noise reduction according to EN 15036-1 standard

LPG kit

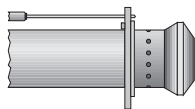

For burning LPG gas, a special kit is available.

BURNER	KIT CODE FOR STANDARD HEAD (*)	KIT CODE FOR EXTENDED HEAD (*)
▶ GAS 3/2	3000657	3000807
▶ GAS 4/2	3000658	3000808
▶ GAS 5/2	3000659	3000809
▶ GAS 6/2	3000753	3000810
▶ GAS 7/2	3000806	3000811
▶ GAS 9/2	3000876	3010028

(*) without CE certification

Town Gas kit

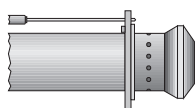

For burning Town Gas, a special kit is available.

BURNER	KIT CODE FOR STANDARD HEAD (*)	KIT CODE FOR EXTENDED HEAD (*)
▶ GAS 3/2	3000742	-
▶ GAS 4/2	3000754	-
▶ GAS 5/2	3000759	-
▶ GAS 6/2	3000768	-
▶ GAS 7/2	3000769	-
▶ GAS 9/2	3010298	-

(*) Without CE certification

Two Stage Gas Burners

GAS/2 SERIES

Burner accessories

PC Interface kit



To connect the RMG control box to a personal computer for the transmission of operation, fault signals and detailed service information, an interface adapter with PC software are available.

BURNER	KIT CODE
► GAS 3/2 - 4/2 - 5/2 - 6/2 - 7/2 - 9/2	3002719

Protection kit (electromagnetic interferences)

When the burner is installed in a room particularly subject to electromagnetic interference (signals emitted over 10 V/m) due for example to INVERTER presence or in systems where the lengths of the thermostat connections is over 20 meters, this specific protection kit is available as an interface between the thermostatic controls and the burner.

BURNER	KIT CODE
► All models	3010386

220-230 V conversion kit









This kit is required to convert the 380-400 V models into the 220 or 230 V version.

BURNER	SUPPORT CODE
► GAS 9/2	20163347

Gas train accessories

Adapters

In certain cases, an adapter must be fitted between the gas train and the burner, when the diameter of the gas train is different from the set diameter of the burner. Below are given the available adapters; please see on the Gas Train list the correct adapter codes to select.

ADAPTER	LENGTH mm	ADAPTER CODE
2"  1" 1/2	70	3000822
3/4"  1" 1/2	31	3000824
DN 65  2" 1/2  2"	300	3000825
DN 80  2" 1/2  2"	300	3000826
1" 1/2  2"	35	3000843
1/2"  1" 1/2	31	20044756

Gas train accessories

Seal control kit



To test the valve seals on the gas train, a special "seal control kit" is available.

BURNER	GAS TRAIN	KIT CODE for 50 Hz operation	KIT CODE for 60 Hz operation
▶ GAS 3/2	MB 405/2 - 407/2 - 410/2 - 412/2 - 415/2 - 420/2	3010123	20168805
	CB 512 - 520/2	3010125	20169320
▶ GAS 4/2	MB 405/2 - 407/2 - 410/2 - 412/2 - 415/2 - 420/2	3010123	20168805
	CB 512/2 - 520/2 - 5065/2	3010125	20169320
▶ GAS 5/2	MB 407/2 - 410/2 - 412/2 - 415/2 - 420/2	3010123	20168805
	CB 512/2 - 520/2 - 5065/2 - 5080/2	3010125	20169320
▶ GAS 6/2	MB 410/2 - 412/2 - 415/2 - 420/2	3010123	20168805
	CB 512/2 - 520/2 - 5065/2 - 5080/2	3010125	20169320
▶ GAS 7/2	MB 412/2 - 415/2 - 420/2	3010123	20168805
	CB 512/2 - 520/2 - 5065/2 - 5080/2	3010125	20169320
▶ GAS 9/2	CB 512/2 - 520/2 - 5065/2 - 5080/2	3809900	20169321

Stabiliser spring



Accessory springs are available to vary the pressure range of the gas train stabilisers.

GAS TRAIN	SPRING COLOUR	SPRING PRESSURE RANGE mbar	SPRING CODE
▶ CB 512/2	Red	25 - 55	3010131
	Black	60 - 110	3010157
	Pink	90 - 150	3090486
▶ CB 520/2	Red	25 - 55	3010132
	Black	60 - 110	3010158
	Pink	100 - 150	3090487
▶ CB 5065/2 - 5080/2	Red	25 - 55	3010133
	Black	60 - 110	3010135
	Pink	100 - 150	3090456
	Grey	140 - 200	3090992

GAS P/M SERIES

The GAS P/M series covers a firing range from 130 to 4885 kW. Operation is featured by progressive two stage operation or full modulation, with an advanced modulating control system and probes. The burners of GAS P/M series are well suited for applications requiring versatility of control (process, steam, refrigerating absorption) where a variable output is needed.

Due to their metal sheet structures, they are specifically suitable for process applications where plastic materials could be easily damaged or deformed. Simplified maintenance is achieved by sliding bars which permit the access to the combustion head without need of removing the burner from the boiler.

A RIELLO burner (Heat Generator), where it is matched with a water-based boiler (Heater Housing) with a nominal output ≤ 400 kW, providing heat for heating purposes and heat to deliver sanitary hot water, can be installed:

- With boilers (heater housings) already in service in the field, for replacement, in conformity to Article 1, paragraph 2, point (G) of the EU Regulation No. 813/2013;
- With boilers (heater housings) on a new installation, put on the market after 26th of September 2015;
- With all new boilers (heater housings), where placed on the market before 26th of September 2015.

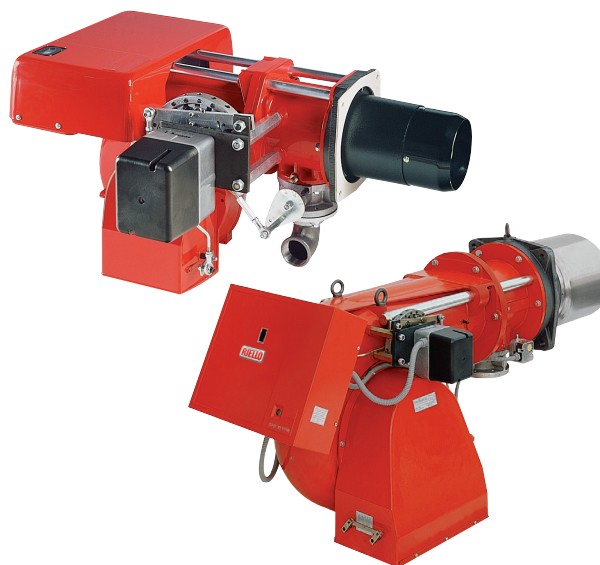

GAS 3 P/M	80/130 ÷	350 kW
GAS 4 P/M	120/180 ÷	470 kW
GAS 5 P/M	155/320 ÷	660 kW
GAS 6 P/M	300/520 ÷	1050 kW
GAS 7 P/M	400/800 ÷	1760 kW
GAS 8 P/M	640/1163 ÷	2210 kW
GAS 9 P/M	870/1744 ÷	3488 kW
GAS 10 P/M	1140/2441 ÷	4885 kW

FIRING RATES

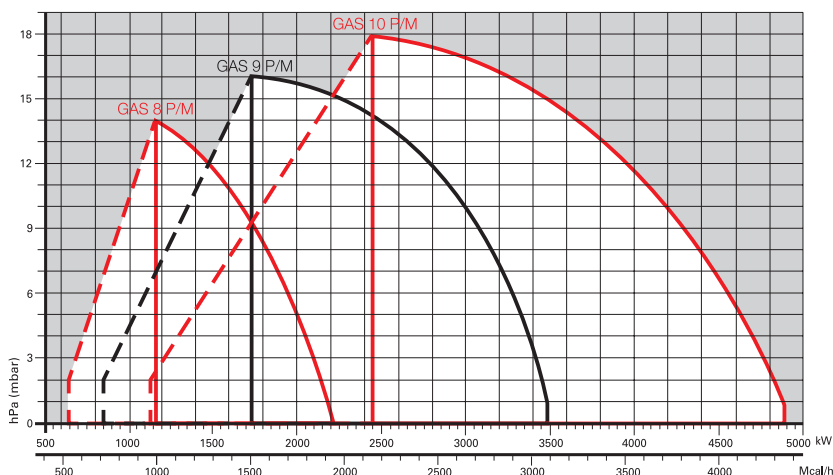
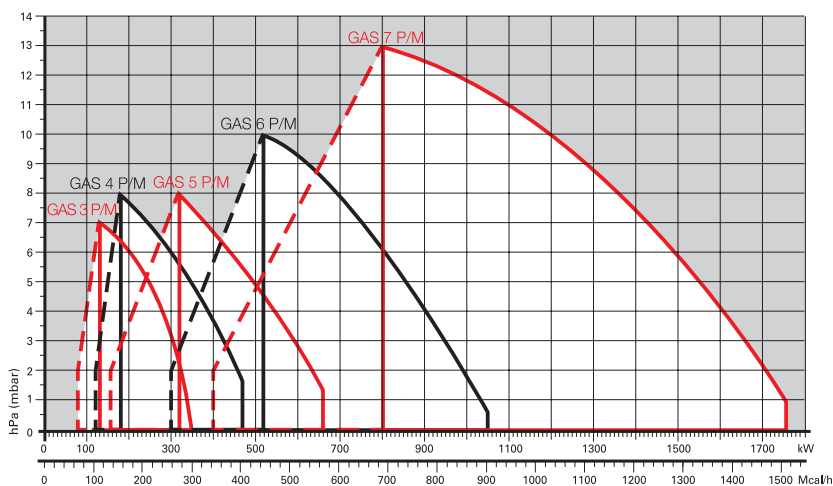

 Useful working field for choosing the burner

 Modulation range

Test conditions conforming to EN676
 Temperature: 20°C
 Pressure: 1013,5 mbar
 Altitude: 0 m a.s.l.

Modulating Gas Burners

GAS P/M SERIES

Overall dimensions (mm)

BURNER

GAS 3 - 4 - 5 - 6 - 7 P/M

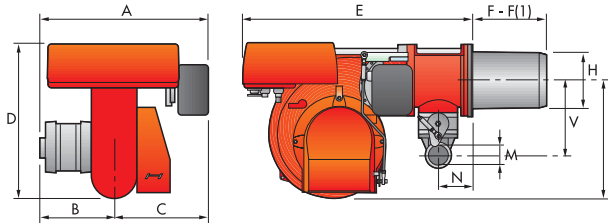

GAS 8 - 9 - 10 P/M

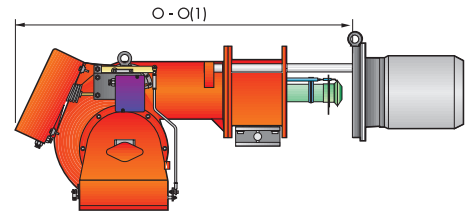
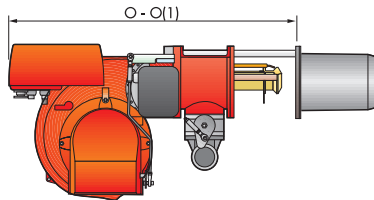
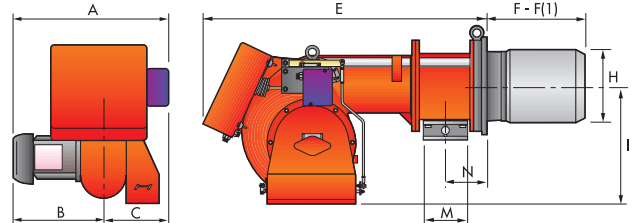

MODEL	A	B	C	D	E	F - F(1)	H	I	M	N	O - O(1)	V
▶ GAS 3 P/M	585	205	380	397	610	185 - 320	140	292	1 1/2"	97	775	225
▶ GAS 4 P/M	585	205	380	397	610	187 - 320	150	292	1 1/2"	97	775	225
▶ GAS 5 P/M	581	226	355	437	645	207 - 365	155	332	1 1/2"	97	810	225
▶ GAS 6 P/M	628	258	370	485	770	227 - 360	175	370	2"	131	966	250
▶ GAS 7 P/M	758	358	400	590	920	240 - 400	220	445	2"	140	1142	305
▶ GAS 8 P/M	755	396	359	-	1090	391 - 501	260	467	DN 80	158	1541 - 1644	-
▶ GAS 9 P/M	817	447	370	-	1200	444 - 574	295	496	DN 80	168	1627 - 1757	-
▶ GAS 10 P/M	917	508	409	-	1320	476 - 606	336	525	DN 80	203	1730 - 1860	-

(1) Length with extended combustion head

BURNER - BOILER MOUNTING FLANGE

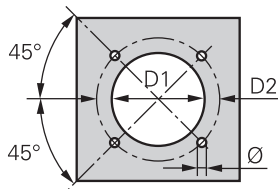

MODEL	D1	D2	Ø
▶ GAS 3 P/M	155	226	M10
▶ GAS 4 P/M	165	226	M10
▶ GAS 5 P/M	165	226	M10
▶ GAS 6 P/M	185	276	M12
▶ GAS 7 P/M	230	325	M12
▶ GAS 8 P/M	265	368	M16
▶ GAS 9 P/M	300	368	M18
▶ GAS 10 P/M	350	438	M20

PACKAGING

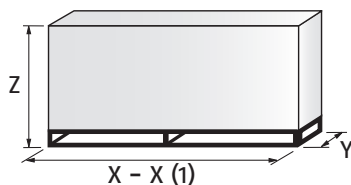

MODEL	X (1)	Y	Z	kg
▶ GAS 3 P/M	930	705	555	37
▶ GAS 4 P/M	930	705	555	43
▶ GAS 5 P/M	930	705	555	46
▶ GAS 6 P/M	1045	705	555	63
▶ GAS 7 P/M	1400	850	650	101
▶ GAS 8 P/M	1740	990	950	195
▶ GAS 9 P/M	2040	1180	1125	240
▶ GAS 10 P/M	2040	1180	1125	310

(1) Length with extended combustion head

GAS P/M SERIES

Specification

DESIGNATION OF SERIES

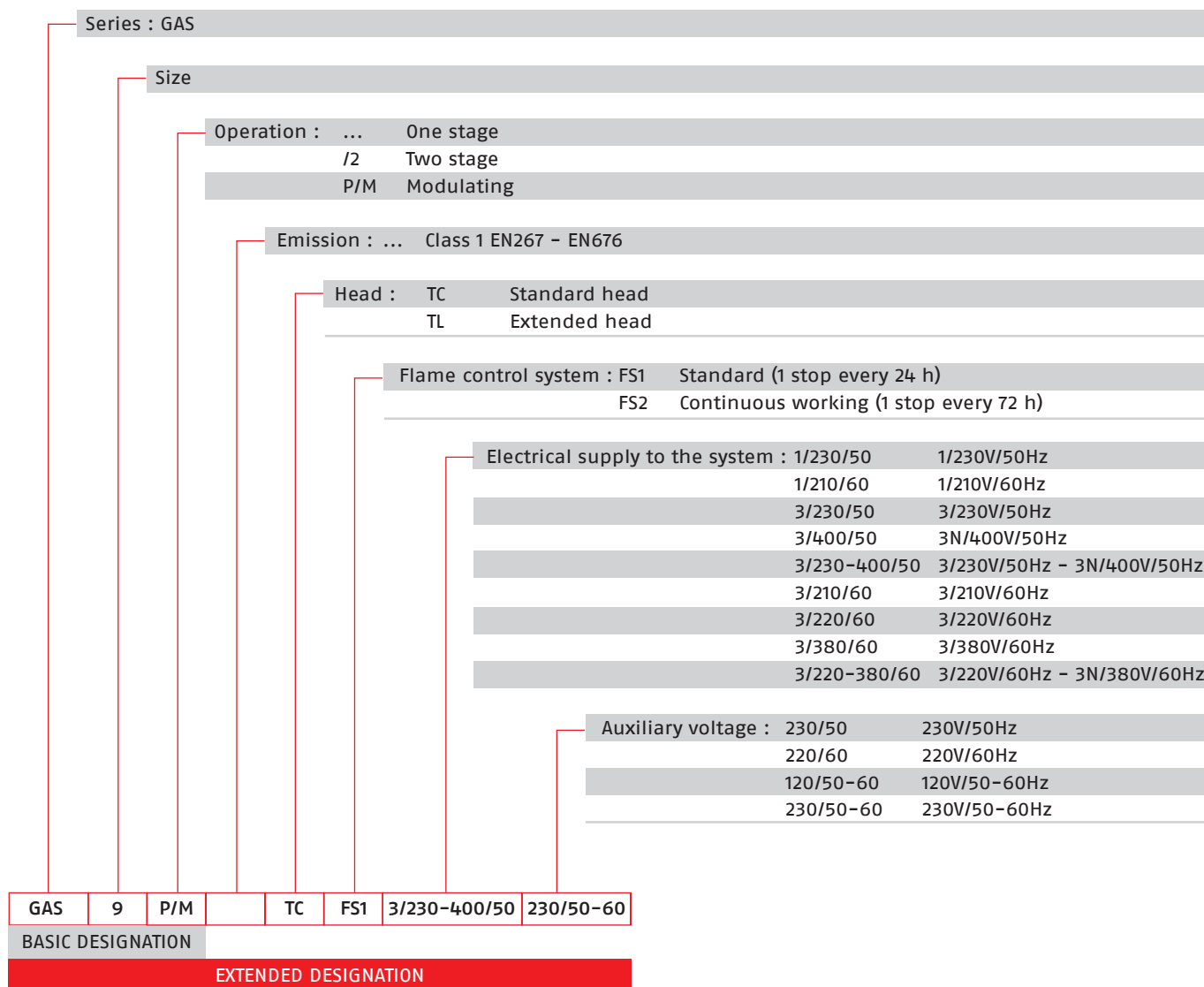

Specification

STATE OF SUPPLY

Monoblock forced draught gas burner, two stage progressive operation or modulating with a kit, made up of:

- Air suction circuit
- Fan with forward curved blades
- Air damper for air setting controlled by a servomotor;
- Combustion head, that can be set on the basis of required output, fitted with:
 - stainless steel end cone, resistant to corrosion and high temperatures
 - ignition electrodes
 - flame stability disk
- Servomotor for air and gas delivery regulation
- Maximum gas pressure switch (except for GAS 3 P/M model and GAS 6 P/M code 3753681)
- Minimum air pressure switch
- Single phase or three phases electrical motor
- Ionisation probe
- Flame inspection window
- Slide bars for easier installation and maintenance
- Protection filter against radio interference
- IP X0D (IP 40) protection level.

Standard equipment:

- 1 gas train flange
- 1 flange gasket
- 1 insulating screen
- 8 screws for fixing the burner flange to the boiler (12 for GAS 8 P/M - GAS 9 P/M and GAS 10 P/M)
- 4 wiring looms for electrical connections
- 1 star delta starter (for GAS 8 P/M - GAS 9 P/M and GAS 10 P/M)
- 2 wiring looms for electrical connections to the star delta starter (for GAS 8 P/M - GAS 9 P/M and GAS 10 P/M)
- 8 washers (for GAS 8 P/M - GAS 9 P/M and GAS 10 P/M)
- 2 bar extensions (only for extended head versions of GAS 8 P/M - GAS 9 P/M and GAS 10 P/M)
- Instruction handbook for installation, use and maintenance
- Spare parts catalogue.

GAS P/M SERIES

Available models

Burners

CODE	MODEL				HEAT OUTPUT		TOTAL ELECTRICAL POWER (kW)	CERTIFICATION	NOTE
					NATURAL GAS (kW)	(Nm ³ /h)			
20159096	GAS 3 P/M	TC	FS1/FS2 1/230/50	230/50-60	80/130-350	8/13-35	0,4	CE 0085AQ0710	(2)(4)
20159118	GAS 4 P/M	TC	FS1/FS2 1/230/50	230/50-60	120/180-470	12/18-47	0,54	CE 0085AQ0710	(2)(4)
20159126	GAS 5 P/M	TC	FS1/FS2 3/230-400/50	230/50-60	155/320-660	15,5/32-66	0,85	CE 0085AQ0710	(2)(4)
20159129	GAS 6 P/M	TC	FS1/FS2 3/230-400/50	230/50-60	300/520-1050	30/52-105	1,9	CE 0085AQ0710	(2)(4)
20159368	GAS 7 P/M	TC	FS1/FS2 3/220-380/60	220/60	400/800-1760	40/80-176	4,5	-	(2)(4)
20159133	GAS 7 P/M	TC	FS1/FS2 3/230-400/50	230/50-60	400/800-1760	40/80-176	4,5	CE 0085AQ0710	(2)(4)
20147902	GAS 8 P/M	TC	FS1/FS2 3/230-400/50	230/50-60	640/1163-2210	64/116-221	5	CE 0085AP0941	(2)(4)
20147903	GAS 8 P/M	TL	FS1/FS2 3/230-400/50	230/50-60	640/1163-2210	64/116-221	5	CE 0085AP0941	(2)(4)
20159370	GAS 9 P/M	TC	FS1/FS2 3/220-380/60	220/60	870/1744-3488	87/174-349	16,9	-	(2)(4)
20147906	GAS 9 P/M	TC	FS1/FS2 3/230/50	230/50-60	870/1744-3488	87/174-349	16,9	CE 0085AP0942	(1)(2)(4)
20147794	GAS 9 P/M	TC	FS1/FS2 3/400/50	230/50-60	870/1744-3488	87/174-349	16,9	CE 0085AP0942	(2)(4)(5)
20147907	GAS 9 P/M	TC	FS1/FS2 3/400/50	230/50-60	870/1744-3488	87/174-349	16,9	CE 0085AP0942	(1)(2)(4)
20147795	GAS 9 P/M	TL	FS1/FS2 3/400/50	230/50-60	870/1744-3488	87/174-349	16,9	CE 0085AP0942	(2)(4)(5)
20147908	GAS 9 P/M	TL	FS1/FS2 3/400/50	230/50-60	870/1744-3488	87/174-349	16,9	CE 0085AP0942	(1)(2)(4)
20148024	GAS 10 P/M	TC	FS1/FS2 3/230/50	230/50-60	1140/2441-4885	114/244-489	16,9	CE 0085AP0943	(1)(2)(4)
20159371	GAS 10 P/M	TC	FS1/FS2 3/380/60	220/60	1140/2441-5000	114/244-500	16,9	-	(1)(2)(4)
20147796	GAS 10 P/M	TC	FS1/FS2 3/400/50	230/50-60	1140/2441-4885	114/244-489	16,9	CE 0085AP0943	(1)(2)(4)
20148960	GAS 10 P/M	TL	FS1/FS2 3/230/50	230/50-60	1140/2441-4885	114/244-489	16,9	CE 0085AP0943	(1)(2)(4)
20147797	GAS 10 P/M	TL	FS1/FS2 3/400/50	230/50-60	1140/2441-4885	114/244-489	16,9	CE 0085AP0943	(1)(2)(4)

(1) Star delta starter (2) with RFG0 control box (3) with LFL control box (4) FS2 operation is allowed with ionization probe only, no other flame sensors can be used.

(5) For the 3/230/50 version use the 220 - 230 V conversion kit (see the burner accessories paragraph)

Natural gas G20 net calorific value: 10 kWh/Nm³ - Density gas G20: 0,71 kg/Nm³

The burners of GAS P/M series are in according to 2016/426/EU - 2014/30/EU - 2014/35/EU - 2006/42 CE Directive and EN 676 Norm.

Due to the improvement applied on the technical specification of some products, some burner codes will change during year 2019. The table below summarizes the correspondence between the previous and the new code.

MODEL				NEW CODE			OLD CODE		
GAS 3 P/M	TC	1/230/50	230/50-60	20159096	FS1/FS2	(2)(4)	3753321	FS1	(3)
GAS 4 P/M	TC	1/230/50	230/50-60	20159118	FS1/FS2	(2)(4)	3753421	FS1	(3)
GAS 5 P/M	TC	3/230-400/50	230/50-60	20159126	FS1/FS2	(2)(4)	3753521	FS1	(3)
GAS 6 P/M	TC	3/230-400/50	230/50-60	20159129	FS1/FS2	(2)(4)	3753621	FS1	(3)
GAS 7 P/M	TC	3/220-380/60	220/60	20159368	FS1/FS2	(2)(4)	3753781	FS1	(3)
GAS 7 P/M	TC	3/230-400/50	230/50-60	20159133	FS1/FS2	(2)(4)	3753721	FS1	(3)
GAS 8 P/M	TC	3/230-400/50	230/50-60	20147902	FS1/FS2	(2)(4)	3753833	FS1	(3)
GAS 8 P/M	TL	3/230-400/50	230/50-60	20147903	FS1/FS2	(2)(4)	3753834	FS1	(3)
GAS 9 P/M	TC	3/230/50	230/50-60	20147906	FS1/FS2	(2)(4)	3754039	FS1	(1)(3)
GAS 9 P/M	TC	3/230-400/50	230/50-60	20147794	FS1/FS2	(2)(4)	3754037	FS1	(3)
GAS 9 P/M	TC	3/400/50	230/50-60	20147907	FS1/FS2	(2)(4)	3754041	FS1	(1)(3)
GAS 9 P/M	TL	3/230-400/50	230/50-60	20147795	FS1/FS2	(2)(4)	3754038	FS1	(3)
GAS 9 P/M	TL	3/400/50	230/50-60	20147908	FS1/FS2	(2)(4)	3754042	FS1	(1)(3)
GAS 10 P/M	TC	3/230/50	230/50-60	20148024	FS1/FS2	(2)(4)	3754135	FS1	(1)(3)
GAS 10 P/M	TC	3/380/60	220/60	20159371	FS1/FS2	(2)(4)	3754187	FS1	(1)(3)
GAS 10 P/M	TC	3/400/50	230/50-60	20147796	FS1/FS2	(2)(4)	3754137	FS1	(1)(3)
GAS 10 P/M	TL	3/230/50	230/50-60	20148960	FS1/FS2	(2)(4)	3754136	FS1	(1)(3)
GAS 10 P/M	TL	3/400/50	230/50-60	20147797	FS1/FS2	(2)(4)	3754138	FS1	(1)(3)

(1) Star delta starter (2) with RFG0 control box (3) with LFL control box (4) FS2 operation is allowed with ionization probe only, no other flame sensors can be used.

Natural gas G20 net calorific value: 10 kWh/Nm³ - Density gas G20: 0,71 kg/Nm³

The burners of GAS P/M series are in according to 2016/426/EU - 2014/30/EU - 2014/35/EU - 2006/42 CE Directive and EN 676 Norm.

Modulating Gas Burners

GAS P/M SERIES

Available models

Gas Trains

CODE	GAS TRAIN			VPS CODE	ADAPTER CODE				
	MODEL	Ø	C.T.		GAS 3 P/M	GAS 4 P/M	GAS 5 P/M	GAS 6 P/M	GAS 7 P/M
3970500*	MB 405/1 - RT 20	Rp 3/4"	-	3010123	3000824		●	●	●
3970553*	MB 407/1 - RT 20	Rp 3/4"	-	3010123	3000824		●	●	●
3970599*	MB 407/1 - RT 52	Rp 3/4"	-	3010123	3000824		●	●	●
3970229*	MB 407/1 - RSM 20	Rp 3/4"	-	3010123	3000824		●	●	●
3970258*	MB 410/1 - RT 52	Rp 1" 1/4	-	3010123	3010124	3010124	3010124	3010126	●
3970554*	MB 410/1 - RT 20	Rp 3/4"	-	3010123	3000824		3000824+		●
3970600*	MB 410/1 - RT 52	Rp 3/4"	-	3010123	3000824		3000843		●
3970230*	MB 410/1 - RSM 20	Rp 3/4"	-	3010123	3000824		3000843		●
3970256*	MB 412/1 - RT 52	Rp 1" 1/2	-	3010123	□	□	□	3000843	
3970144*	MB 412/1 - RT 20	Rp 1" 1/2	-	3010123	□	□	□		
3970197**	MB 412/1 CT RT 20	Rp 1" 1/2	◆	-	□	□	□		
3970231*	MB 412/1 - RSM 20	Rp 1" 1/2	-	3010123	□	□	□		
3970180*	MB 415/1 - RT 30	Rp 1" 1/2	-	3010123	□	□	□		
3970198**	MB 415/1 CT RT 30	Rp 1" 1/2	◆	-	□	□	□		
3970250*	MB 415/1 - RT 52	Rp 1" 1/2	-	3010123	□	□	□		
3970253**	MB 415/1 CT RT 52	Rp 1" 1/2	◆	-	□	□	□		
3970232*	MB 415/1 - RSM 30	Rp 1" 1/2	-	3010123	□	□	□		
3970181*	MB 420/1 - RT 30	Rp 2"	-	3010123	3000822		□		
3970182**	MB 420/1 CT RT 30	Rp 2"	◆	-	3000822		□	□	
3970257*	MB 420/1 - RT 52	Rp 2"	-	3010123	3000822		□	□	
3970252**	MB 420/1 CT RT 52	Rp 2"	◆	-	3000822		□	□	
3970233*	MB 420/1 - RSM 30	Rp 2"	-	3010123	3000822		□	□	
3970234**	MB 420/1 CT RSM 30	Rp 2"	◆	-	3000822		□	□	
3970221*	MBC 1200/1 - RSM 60	Rp 2"	-	3010123	3000822		□	□	
3970225**	MBC 1200/1 CT RSM 60	Rp 2"	◆	-	3000822		□	□	
3970222*	MBC 1900/1 - FSM 40	DN 65	-	3010123	●	●	3000825		
3970226*	MBC 1900/1 CT FSM 40	DN 65	◆	-	●	●	3000825		
3970223*	MBC 3100/1 - FSM 40	DN 80	-	3010123	●	●	●	3000826	
3970227**	MBC 3100/1 CT FSM 40	DN 80	◆	-	●	●	●	3000826	
3970224*	MBC 5000/1 - FSM 80	DN 100	-	3010123	●	●	●	●	●
3970228**	MBC 5000/1 CT FSM 80	DN 100	◆	-	●	●	●	●	●
3970145*	CB 512/1 - RSM 30	Rp 1" 1/2	-	3010123	□	□	□	3000843	
20045589**	CB 512/1 CT RSM 30	Rp 1" 1/2	◆	-	□	□	□	3000843	
3970146*	CB 520/1 - RSM 30	Rp 2"	-	3010123	3000822		□	□	
3970160**	CB 520/1 CT RSM 30	Rp 2"	◆	-	3000822		□	□	
20044659*	CB 525/1 - RSM 30	Rp 2"	-	3010123	3000822		□	□	
20044660**	CB 525/1 CT RSM 30	Rp 2"	◆	-	3000822		□	□	
3970147*	CB 5065/1 - FSM 30	DN 65	-	3010123	●	3000825			
3970161**	CB 5065/1 CT FSM 30	DN 65	◆	-	●	3000825			
3970148*	CB 5080/1 - FSM 30	DN 80	-	3010123	●	●	3000826+	3000826	
3970162**	CB 5080/1 CT FSM 30	DN 80	◆	-	●	●	3000822	3000826	
3970149*	CB 50100/1 - FSM 30	DN 100	-	3010123	●	●	●	3010370+ 3000826	
3970163**	CB 50100/1 CT FSM 30	DN 100	◆	-	●	●	●	3010370+ 3000826	
20015871*	CB 50125/1 - FSM 30	DN 125	-	3010123	●	●	●	●	3010224+
3970196**	CB 50125/1 CT FSM 30	DN 125	◆	-	●	●	●	●	3000826

GAS P/M SERIES

Available models

Gas Trains

CODE	GAS TRAIN			VPS CODE	ADAPTER CODE		
	MODEL	Ø	C.T.		GAS 8 P/M	GAS 9 P/M	GAS 10 P/M
3970180*	MB 415/1 - RT 30	Rp 1" 1/2	-	3010123	3000843+ 3010495+ 3000826	●	●
3970198**	MB 415/1 CT RT 30	Rp 1" 1/2	◆	-		●	●
3970250*	MB 415/1 - RT 52	Rp 1" 1/2	-	3010123		●	●
3970253**	MB 415/1 CT RT 52	Rp 1" 1/2	◆	-		●	●
3970232*	MB 415/1 - RSM 30	Rp 1" 1/2	-	3010123	3010495+ 3000826	●	●
3970181*	MB 420/1 - RT 30	Rp 2"	-	3010123		●	●
3970182**	MB 420/1 CT RT 30	Rp 2"	◆	-		●	●
3970257*	MB 420/1 - RT 52	Rp 2"	-	3010123		●	●
3970252**	MB 420/1 CT RT 52	Rp 2"	◆	-		●	●
3970233*	MB 420/1 - RSM 30	Rp 2"	-	3010123		●	●
3970234**	MB 420/1 CT RSM 30	Rp 2"	◆	-		●	●
3970221*	MBC 1200/1 - RSM 60	Rp 2"	-	3010123		3010495+3000826	
3970225**	MBC 1200/1 CT RSM 60	Rp 2"	◆	-			
3970222*	MBC 1900/1 - FSM 40	DN 65	-	3010123	3000831		
3970226**	MBC 1900/1 CT FSM 40	DN 65	◆	-			
3970223*	MBC 3100/1 - FSM 40	DN 80	-	3010123	3000832		
3970227**	MBC 3100/1 CT FSM 40	DN 80	◆	-			
3970224*	MBC 5000/1 - FSM 80	DN 100	-	3010123	●	3010127	
3970228**	MBC 5000/1 CT FSM 80	DN 100	◆	-	●		
3970145*	CB 512/1 - RSM 30	Rp 1" 1/2	-	3010123	3000843+3010495+3000826		
20045589**	CB 512/1 CT RSM 30	Rp 1" 1/2	◆	-			
3970146*	CB 520/1 - RSM 30	Rp 2"	-	3010123	3010495+3000826		
3970160**	CB 520/1 CT RSM 30	Rp 2"	◆	-			
20044659*	CB 525/1 - RSM 30	Rp 2"	-	3010123			
20044660**	CB 525/1 CT RSM 30	Rp 2"	◆	-			
3970147*	CB 5065/1 - FSM 30	DN 65	-	3010123	3000831		
3970161**	CB 5065/1 CT FSM 30	DN 65	◆	-			
3970148*	CB 5080/1 - FSM 30	DN 80	-	3010123	3000832		
3970162**	CB 5080/1 CT FSM 30	DN 80	◆	-			
3970149*	CB 50100/1 - FSM 30	DN 100	-	3010123	3010127		
3970163**	CB 50100/1 CT FSM 30	DN 100	◆	-			
20015871*	CB 50125/1 - FSM 30	DN 125	-	3010123	3090940		
3970196**	CB 50125/1 CT FSM 30	DN 125	◆	-			

Please see designation of Gas Train Series in the page before the Catalogue index.

* 230V/50Hz -220V/60Hz electrical supply.

** 230V/50Hz electrical supply.

The valve seal control device is compulsory (conforming to EN 676) on gas trains to burners with a maximum output over 1200 kW.

To select the gas train please refer to the technical data leaflet and/or instruction manual.

C.T. Gas valve leak detection control device:

- gas train not equipped with leak detection control device; this device can be ordered separately - see VPS column - and installed later.

◆ gas train equipped with leak detection control device.

VPS Valve leak detection control device. Supplied separately from the gas train (please see Gas train accessories paragraph for both 50 Hz and 60 Hz codes).

● Not available.

□ Additional adapter not necessary, the gas train may be connected directly to the burner.

Modulating Gas Burners

GAS P/M SERIES

Burner accessories

Extended head kit

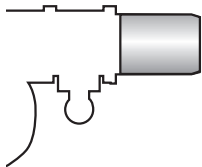

“Standard head” burners can be transformed into “extended head” versions, by using the special kit.

BURNER	STANDARD HEAD LENGTH (mm)	EXTENDED HEAD LENGTH (mm)	KIT CODE
▶ GAS 3 P/M	185	320	3000605
▶ GAS 4 P/M	187	320	3000606
▶ GAS 5 P/M	207	365	3000607
▶ GAS 6 P/M	227	360	3000608
▶ GAS 7 P/M	240	400	3000678

Spacer kit

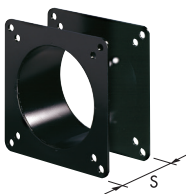

If burner head penetration into the combustion chamber needs reducing, varying thickness spacers are available, as given in the following list.

BURNER	SPACER THICKNESS S (mm)	KIT CODE
▶ GAS 3 - 4 - 5 - 6 P/M	142	3000755
▶ GAS 7 - 8 P/M	102	3000722
▶ GAS 9 P/M	122	3000723
▶ GAS 10 P/M	130	3000751

Continuous ventilation kit



If the burner requires continuous ventilation in the stages without flame, a special kit is available as given in the following table.

BURNER	KIT CODE
▶ GAS 3 - 4 - 5 - 6 - 7 P/M	3010030

Burner support

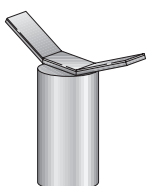

For easier maintenance, a mobile burner support has been designed, which means the burner can be dismantled without the need of forklift trucks.

BURNER	SUPPORT CODE
▶ GAS 8 P/M - GAS 10 P/M	3000731

Burner accessories

Sound proofing box

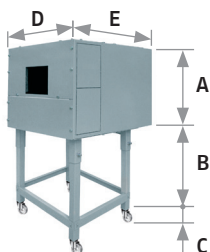

If noise emission needs reducing even further, sound-proofing boxes are available. When a lower "B" dimension is required, it is available the Box Support Kit code 20065135 which allows to reduce it at the fixed dimension of 55 mm. The sound-proofing boxes are not suitable for outdoor use.

BURNER	BOX TYPE	A (mm)	B (mm) min-max	C (mm)	D (mm)	E (mm)	[dB(A)] (*)	BOX CODE
▶ GAS 3 - 4 - 5 - 6 P/M	C1/3	650	372 - 980	110	690	770	10	3010403
▶ GAS 7 - 8 P/M	C4/5	850	160 - 980	110	980	930	10	3010404
▶ GAS 9 - 10 P/M	C7	1255	160 - 980	110	1140	1345	10	3010376

(*) Average noise reduction according to EN 15036-1 standard

LPG kit

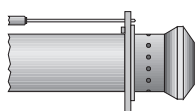

For burning LPG gas, a special kit is available.

BURNER	KIT CODE FOR STANDARD HEAD (*)	KIT CODE FOR EXTENDED HEAD (*)
▶ GAS 3 P/M	3000657	3000807
▶ GAS 4 P/M	3000658	3000808
▶ GAS 5 P/M	3000659	3000809
▶ GAS 6 P/M	3000753	3000810
▶ GAS 7 P/M	3000806	3000811
▶ GAS 8 P/M	3000875	3010029
▶ GAS 9 P/M	3000876	3010028
▶ GAS 10 P/M	3010152	3010153

(*) Without CE certification

Town Gas kit

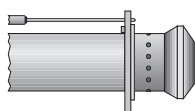

For burning Town Gas, a special kit is available.

BURNER	KIT CODE FOR STANDARD HEAD (*)	KIT CODE FOR EXTENDED HEAD (*)
▶ GAS 3 P/M	3000742	-
▶ GAS 4 P/M	3000754	-
▶ GAS 5 P/M	3000759	-
▶ GAS 6 P/M	3000768	-
▶ GAS 7 P/M	3000769	-
▶ GAS 8 P/M	-	-
▶ GAS 9 P/M	3010298	3010298
▶ GAS 10 P/M	3010300	3010300

(*) Without CE certification

Modulating Gas Burners

GAS P/M SERIES

Burner accessories

Accessories for modulating operation



To obtain modulating operation, the GAS P/M series of burners requires a regulator. For remote setpoint use RWF 55.

BURNER	REGULATOR TYPE	REGULATOR CODE
▶ GAS 3 - 4 - 5 - 6 - 7 P/M	RWF 50.2	20105445
	RWF 55.5	20105717
▶ GAS 8 - 9 - 10 P/M	RWF 50.2	20100018
	RWF 55.5	20101965



The relative temperature or pressure probes fitted to the regulator, must be chosen on the basis of the application.

BURNER	PROBE TYPE	RANGE (°C) (bar)	PROBE CODE
▶ GAS 3 - 4 - 5 - 6 - 7 P/M GAS 8 - 9 - 10 P/M	Temperature PT 100	-100 ÷ 500°C	3010110
	Pressure 4 ÷ 20 mA	0 ÷ 2,5 bar	3010213
	Pressure 4 ÷ 20 mA	0 ÷ 16 bar	3010214
	Pressure 4 ÷ 20 mA	0 ÷ 25 bar	3090873

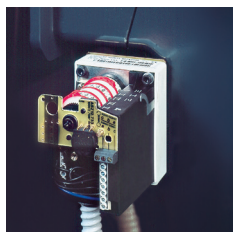

Depending on the servomotor fitted to the burner, a three-pole potentiometer (1000 Ω) can be installed to check the position of the servomotor.

BURNER	POTENTIOMETER KIT CODE
▶ GAS 3 - 4 - 5 - 6 - 7 P/M GAS 8 - 9 - 10 P/M	20096322
	3010021

220-230 V conversion kit











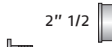

This kit is required to convert the 380-400 V models into the 220 or 230 V version.

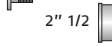
BURNER	SUPPORT CODE
▶ GAS 9 P/M	20163347

Gas train accessories

Adapters

In certain cases, an adapter must be fitted between the gas train and the burner, when the diameter of the gas train is different from the set diameter of the burner. Below are given the available adapters; please see on the Gas Train list the correct adapter codes to select.

ADAPTER	LENGTH mm	ADAPTER CODE
2"  1" 1/2	70	3000822
3/4"  1" 1/2	31	3000824
DN 65  2" 1/2 	300	3000825
DN 80  2" 1/2 	300	3000826
1" 1/2  2"	35	3000843
DN 65  DN 80	320	3000831
DN 80  DN 80	320	3000832
DN 100  DN 80	320	3010127
2"  2"	58	3010495
1" 1/4  1" 1/2	35	3010124
1" 1/4  2"	35	3010126

Seal control kit



To test the valve seals on the gas train, a special "seal control kit" is available. The valve seal control device is compulsory (EN 676) on gas trains to burners with a maximum output over 1200 kW. The seal control is type VPS 504.

GAS TRAIN	KIT CODE for 50 Hz operation	KIT CODE for 60 Hz operation
▶ MB/1 type	3010123	20168805
▶ MBC/1 type	3010123	20168805
▶ CB/1 type	3010123	20168805

Gas train accessories

Stabiliser spring



To vary the pressure range of the gas train stabilisers, accessory springs are available. The following table shows these accessories with their application range. Please refer to the technical manual for the correct choice of spring.

GAS TRAIN	SPRING COLOUR	SPRING PRESSURE RANGE mbar	SPRING CODE
▶ MBC 1900/1 – 3100/1 MBC 5000/1	White	4 – 20	3010381
	Red	20 – 40	3010382
	Black	40 – 80	3010383
	Green	80 – 150	3010384
▶ CB 512/1	Red	25 – 55	3010131
	Black	60 – 110	3010157
	Pink	90 – 150	3090486
▶ CB 520/1 – 525/1	Red	25 – 55	3010132
	Black	60 – 110	3010158
	Pink	100 – 150	3090487
▶ CB 5065/1 – 5080/1	Red	25 – 55	3010133
	Black	60 – 110	3010135
	Pink	100 – 150	3090456
	Grey	140 – 200	3090992
▶ CB 50100/1	Red	25 – 55	3010134
	Black	60 – 110	3010136
	Pink	100 – 150	3090489
	Grey	140 – 200	3092174

RLS 68÷160/M MX SERIES

The RLS/M MX series of burners covers a firing range from 350 to 1840 kW, and they have been designed for use in low or medium temperature hot water boilers, hot air or steam boilers, diathermic oil boilers.

Operation is "two stage" at the oil side and "modulating" at the gas side with the installation of a PID logic regulator and respective probes.

RLS/M MX series burners guarantees high efficiency levels in all the various applications, thus reducing fuel consumption and running costs.

Optimisation of sound emissions is guaranteed by the special design of air suction circuit and the use of sound proofing material.

The exclusive design ensures reduced dimensions, simple use and maintenance. A wide range of accessories guarantees elevated working flexibility.



RLS 68/M MX	200/350 ÷ 860	kW
RLS 120/M MX	300/600 ÷ 1200	kW
RLS 160/M MX	300/930 ÷ 1840	kW

FIRING RATES

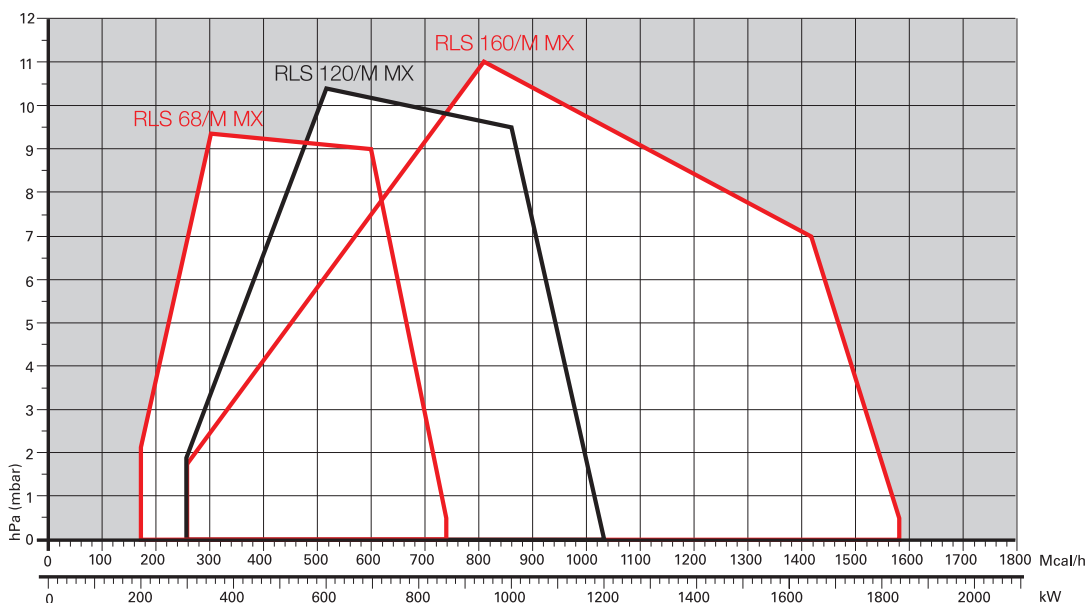

Low NOx Modulating Dual Fuel Burners

RLS 68÷160/M MX SERIES

Overall dimensions (mm)

BURNER

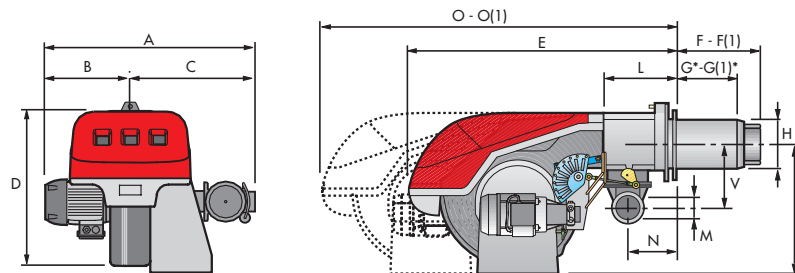

MODEL	A	B	C	D	E	F - F(1)	G* - G(1)*	H	I	L	M	N	O - O (1)	V
► RLS 68/M MX	691	296	395	555	840	260 - 395	200 - 335	189	430	214	2"	134	1161 - 1300	221
► RLS 120/M MX	733	338	395	555	840	260 - 395	200 - 335	189	430	214	2"	134	1161 - 1300	221
► RLS 160/M MX	843	366	477	555	863	373 - 503	272 - 402	221	430	237	2"	141	1442 - 1589	186

(1) Length with extended combustion head.

* Maximum depth of the boiler door including the depth of the burner flange insulating gasket.

BURNER - BOILER MOUNTING FLANGE

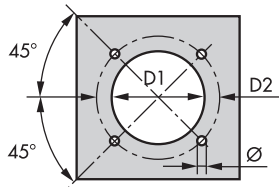

MODEL	D1	D2	Ø
► RLS 68-120/M MX	195	275 - 325	M12
► RLS 160/M MX	230	325 - 368	M16

PACKAGING

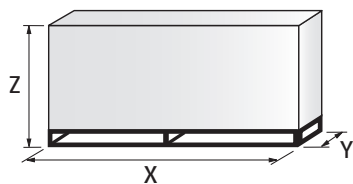

MODEL	X (1)	Y	Z	kg
► RLS 68/M MX	1400	975	645	115
► RLS 120/M MX	1400	975	645	120
► RLS 160/M MX	1400	975	645	135

(1) Length with standard and extended combustion head.

RLS 68÷160/M MX SERIES

Specification

DESIGNATION OF SERIES

Series: R	
Fuel: S Natural Gas	
L Light oil	
LS Light oil/Natural Gas	
N Heavy oil	
Size:	
Setting: /1 Single stage	
/B Two stage	
/M Modulating-Mechanical cam	
/E Electronic cam	
/P Proportioning air/gas valve	
/EV Electronic cam predisposed for variable speed (with inverter)	
/EVi Electronic cam with integrated inverter	
Emission: ... or C11	Class 1 EN267 - EN676
MZ or C22	Class 2 EN267 - EN676
BLU or C33	Class 3 EN267 - EN676
MX or C23	Class 2 EN267 - Class 3 EN676
C13	Class 1 EN267 - Class 3 EN676
Head length: TC	standard head
TL	extended head
Flame control system: FS1	Standard/Intermittent (at least 1 stop every 24 h)
FS2	Continuous (1 stop every 72 h)
Electrical supply to the system:	
1/230/50	1/230V/50Hz
3/230/50	3/230V/50Hz
3/400/50	3/400V/50Hz
3/230-400/50	3/230V/50Hz - 3N/400V/50Hz
3/220/60	3/220V/60Hz
3/380/60	3N/380V/60Hz
3/220-380/60	3/220/60Hz - 3N/380V/60Hz
Auxiliary voltage: 230/50	230V/50Hz
110/50-60	110V/50-60Hz

R	LS	160	/M	MX	TC	FS1	3/400/50	230/50
---	----	-----	----	----	----	-----	----------	--------

BASIC DESIGNATION

EXTENDED DESIGNATION



Low NOx Modulating Dual Fuel Burners

RLS 68÷160/M MX SERIES

Specification

STATE OF SUPPLY

Monoblock forced draught Low NOx dual fuel burner with two stage operation at the oil side and two stage progressive or modulating operation at the gas side, with a specific kit, fully automatic, made up of:

- air suction circuit lined with sound-proofing material
- centrifugal fan with high performance and low sound emissions
- air damper for air flow setting and butterfly valve for regulating gas output controlled by a servomotor with variable cam
- starting motor at 2800 rpm, three-phase 400V with neutral, 50Hz
- low emission combustion head, that can be set on the basis of required output, fitted with:
 - stainless steel end cone, resistant to corrosion and high temperatures
 - ignition electrodes
 - gas distributor
 - flame stability disk
- maximum gas pressure switch to stop the burner in the case of excess pressure on the fuel supply line
- minimum air pressure switch stops the burner in case of insufficient air quantity at the combustion head
- gears pump for high pressure fuel supply
- pump starting motor
- oil safety valves
- two oil valves (1st and 2nd stage)
- burner safety control box
- UV photocell for flame detection
- burner on/off selection switch
- manual or automatic output increase/decrease selection switch
- Oil/Gas selector
- flame inspection window
- slide bars for easier installation and maintenance
- protection filter against radio interference
- IP 44 electric protection level.

Standard equipment:

- 1 gas train flange
- 1 flange gasket
- 4 screws for fixing the flange
- 1 thermal screen
- 4 screws for fixing the burner flange to the boiler
- 2 flexible pipes for connection to the oil supply network
- 2 nipples for connection to the pump with gaskets
- Instruction handbook for installation, use and maintenance
- Spare parts catalogue.

RLS 68÷160/M MX SERIES

Available models

Burners

CODE	MODEL	HEAT OUTPUT			TOTAL ELECTRICAL POWER (kW)	CERTIFICATION	NOTE
		(kW)	LIGHT OIL (kg/h)	NATURAL GAS (Nm ³ /h)			
20147784	RLS 68/M MX TC FS1/FS2 3/230-400/50 230/50-60	200/350-860	17/30-73	27/40-100	2,2	CE 0085BP0175	(1)
20147785	RLS 68/M MX TL FS1/FS2 3/230-400/50 230/50-60	200/350-860	17/30-73	27/40-100	2,2	CE 0085BP0175	(1)
20147786	RLS 120/M MX TC FS1/FS2 3/230-400/50 230/50-60	300/600-1200	25/50-101	37/70-140	3,0	CE 0085BP0175	(1)
20147788	RLS 120/M MX TL FS1/FS2 3/230-400/50 230/50-60	300/600-1200	25/50-101	37/70-140	3,0	CE 0085BP0175	(1)
20147789	RLS 160/M MX TC FS1/FS2 3/400/50 230/50-60	300/930-1840	25/78-155	30/93-184	6,0	CE 0085BN0625	(1)
20147790	RLS 160/M MX TL FS1/FS2 3/400/50 230/50-60	300/930-1840	25/78-155	30/93-184	6,0	CE 0085BN0625	(1)

Net calorific value light oil: 11,8 kWh/kg; 10.200 kcal/kg - Viscosity at 20°C: 4-6 mm²/s (cSt).

Net calorific value G20 gas: 10 kWh/Nm³; 8.600 kcal/Nm³ - Density: 0,71 kg/Nm³.

The burners of RLS/M MX series are in according to 2016/426/EU - 2014/30/EU - 2014/35/EU - 2006/42 CE Directive and EN 267 - 676 Norm.

Due to the improvement applied on the technical specification of some products, some burner codes will change during year 2019. The table below summarizes the correspondence between the previous and the new code.

MODEL						NEW CODE		OLD CODE	
RLS 68/M MX	TC	FS1/FS2	3/230-400/50	230/50-60	20147784	(1)	3898010	(2)	
RLS 68/M MX	TL	FS1/FS2	3/230-400/50	230/50-60	20147785	(1)	3898011	(2)	
RLS 120/M MX	TC	FS1/FS2	3/230-400/50	230/50-60	20147786	(1)	3898110	(2)	
RLS 120/M MX	TL	FS1/FS2	3/230-400/50	230/50-60	20147788	(1)	3898111	(2)	
RLS 160/M MX	TC	FS1/FS2	3/400/50	230/50-60	20147789	(1)	3898210	(2)	
RLS 160/M MX	TC	FS1/FS2	3/400/50	230/50-60	20147790	(1)	3898211	(2)	

Net calorific value light oil: 11,8 kWh/kg; 10.200 kcal/kg - Viscosity at 20°C: 4-6 mm²/s (cSt).

Net calorific value G20 gas: 10 kWh/Nm³; 8.600 kcal/Nm³ - Density: 0,71 kg/Nm³.

The burners of RLS/M series are in according to 2016/426/EU - 2014/30/EU - 2014/35/EU - 2006/42 CE Directive and EN 676 Norm.

(1) With RFGO control box.

(2) With LFL control box.

Low NOx Modulating Dual Fuel Burners

RLS 68÷160/M MX SERIES

Available models

Gas Trains

CODE	GAS TRAIN			VPS CODE	ADAPTER CODE		
	MODEL	Ø	C.T.		RLS 68	RLS 120	RLS 160
3970599*	MB 407/1 - RT 52	Rp ¾"	-	3010123	3000824+ 3000843	●	●
3970553*	MB 407/1 - RT 20	Rp ¾"	-	3010123		●	●
3970229*	MB 407/1 - RSM 20	Rp ¾"	-	3010123		●	●
3970258*	MB 410/1 - RT 52	Rp 1" ¼"	-	3010123	3010126		●
3970554*	MB 410/1 - RT 20	Rp ¾"	-	3010123	3000824+ 3000843		●
3970600*	MB 410/1 - RT 52	Rp ¾"	-	3010123			●
3970230*	MB 410/1 - RSM 20	Rp ¾"	-	3010123			●
3970256*	MB 412/1 - RT 52	Rp 1" ½"	-	3010123	3000843		
3970144*	MB 412/1 - RT 20	Rp 1" ½"	-	3010123			
3970197**	MB 412/1 CT RT 20	Rp 1" ½"	◆	-			
3970231*	MB 412/1 - RSM 20	Rp 1" ½"	-	3010123			
3970180*	MB 415/1 - RT 30	Rp 1" ½"	-	3010123			
3970198**	MB 415/1 CT RT 30	Rp 1" ½"	◆	-			
3970250*	MB 415/1 - RT 52	Rp 1" ½"	-	3010123			
3970253**	MB 415/1 CT RT 52	Rp 1" ½"	◆	-			
3970232*	MB 415/1 - RSM 30	Rp 1" ½"	-	3010123			
3970181*	MB 420/1 - RT 30	Rp 2"	-	3010123			
3970182**	MB 420/1 CT RT 30	Rp 2"	◆	-	□	□	□
3970257*	MB 420/1 - RT 52	Rp 2"	-	3010123	□	□	□
3970252**	MB 420/1 CT RT 52	Rp 2"	◆	-	□	□	□
3970233*	MB 420/1 - RSM 30	Rp 2"	-	3010123	□	□	□
3970234**	MB 420/1 CT RSM 30	Rp 2"	◆	-	□	□	□
3970221*	MBC 1200/1 - RSM 60	Rp 2"	-	3010123	□	□	□
3970225**	MBC 1200/1 CT RSM 60	Rp 2"	◆	-	□	□	□
3970222*	MBC 1900/1 - FSM 40	DN 65	-	3010123	3000825		
3970226**	MBC 1900/1 CT FSM 40	DN 65	◆	-			
3970223*	MBC 3100/1 - FSM 40	DN 80	-	3010123	3000826		
3970227**	MBC 3100/1 CT FSM 40	DN 80	◆	-			
3970145*	CB 512/1 - RSM 30	Rp 1" ½"	-	3010123	3000843		
20045589**	CB 512/1 CT RSM 30	Rp 1" ½"	◆	-			
3970146*	CB 520/1 - RSM 30	Rp 2"	-	3010123	□	□	□
3970160**	CB 520/1 CT RSM 30	Rp 2"	◆	-	□	□	□
20044659*	CB 525/1 - RSM 30	Rp 2"	-	3010123	□	□	□
20044660**	CB 525/1 CT RSM 30	Rp 2"	◆	-	□	□	□
3970147*	CB 5065/1 - FSM 30	DN 65	-	3010123	3000825		
3970161**	CB 5065/1 CT FSM 30	DN 65	◆	-			
3970148*	CB 5080/1 - FSM 30	DN 80	-	3010123	3000826		
3970162**	CB 5080/1 CT FSM 30	DN 80	◆	-			
3970149*	CB 50100/1 - FSM 30	DN 100	-	3010123	3010370 + 3000826		
3970163**	CB 50100/1 CT FSM 30	DN 100	◆	-			
20015871*	CB 50125/1 - FSM 30	DN 125	-	3010123	●	3010224 + 3000826	
3970196**	CB 50125/1 CT FSM 30	DN 125	◆	-	●		

Please see designation of Gas Train Series in the page before the Catalogue index.

* 230V/50Hz -220V/60Hz electrical supply.

** 230V/50Hz electrical supply.

The valve seal control device is compulsory (conforming to EN 676) on gas trains to burners with a maximum output over 1200 kW.

To select the gas train please refer to the technical data leaflet and/or instruction manual.

C.T. Gas valve leak detection control device:

- gas train not equipped with leak detection control device; this device can be ordered separately - see VPS column - and installed later.

◆ gas train equipped with leak detection control device.

VPS Valve leak detection control device. Supplied separately from the gas train (please see Gas train accessories paragraph for both 50 Hz and 60 Hz codes).

● Not available.

□ Additional adapter not necessary, the gas train may be connected directly to the burner.

RLS68÷160/M MX SERIES

Burner accessories

Nozzles type 60° B



The nozzles must be ordered separately. The following table shows the features and codes on the basis of the maximum required fuel output.

NOTE: each burner needs N° 2 nozzles.

BURNER	RATED DELIVERY kg/h (*)	GPH	NOZZLE	
▶ RLS 68-120/M MX	21,2	5,00	3042192	
	23,3	5,50	3042202	
	25,5	6,00	3042212	
	27,6	6,50	3042222	
	29,7	7,00	3042232	
	31,8	7,50	3042242	
	33,9	8,00	3042252	
	36,1	8,50	3042262	
	38,2	9,00	3042586	
	40,3	9,50	3042282	
	▶ RLS/M MX	42,4	10,00	3042292
		46,7	11,00	3042312
50,9		12,00	3042322	
55,1		13,00	3042332	
59,4		14,00	3042352	
63,6		15,00	3042362	
67,9		16,00	3042382	
72,1		17,00	3042392	
76,4		18,00	3042412	
80,6		19,00	3042422	
▶ RLS 160/M MX	84,8	20,00	3042442	
	93,3	22,00	3042462	
	101,8	24,00	3042472	
	110,3	26,00	3042482	
	118,8	28,00	20018051	

(*) Nozzle rated delivery is referred to atomized pressure

Extended head kit

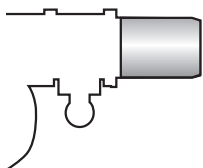

"Standard head" burners can be transformed into "extended head" versions, by using the special kit. The kits available for the various burners, giving the original and the extended lengths, are listed below.

BURNER	STANDARD HEAD LENGTH (mm)	EXTENDED HEAD LENGTH (mm)	KIT CODE
▶ RLS 68-120/M MX	260	395	3010360
▶ RLS 160/M MX	373	503	3010441 *

* Kit to be used on burners recognizable by a serial number that is over or equal to 02426XXXXX, for burners with a serial number that is under or equal to 02416XXXXX please use the Kit coded 3010340

Low NOx Modulating Dual Fuel Burners

RLS 68÷160/M MX SERIES

Burner accessories

Spacer kit

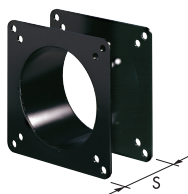

If burner head penetration into the combustion chamber needs reducing, varying thickness spacers are available, as given in the following table:

BURNER	SPACER THICKNESS S (mm)	KIT CODE
► RLS/M MX	102	3000722

Ground fault interrupter kit



A "Ground fault interrupter kit" is available as a safety device for electrical system fault.

BURNER	KIT CODE
► RLS/M MX	20098337

Continuous ventilation kit



If the burner requires continuous ventilation in the stages without flame, a special kit is available as given in the following table.

BURNER	KIT CODE
► RLS/M MX	3010094

Sound proofing box

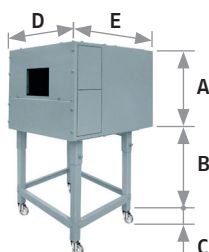

If noise emission needs reducing even further, sound-proofing boxes are available. When a lower "B" dimension is required, it is available the Box Support Kit code 20065135 which allows to reduce it at the fixed dimension of 55 mm. The sound-proofing boxes are not suitable for outdoor use.

BURNER	BOX TYPE	A (mm)	B (mm) min-max	C (mm)	D (mm)	E (mm)	[dB(A)] (*)	BOX CODE
► RLS 68-120-160/M MX	C4/5	850	160 - 980	110	980	930	10	3010404

(*) Average noise reduction according to EN 15036-1 standard

Clean contacts kit

BURNER	KIT CODE
► RLS 68-120/M MX	20123294

RLS 68÷160/M MX SERIES

Burner accessories

Accessories for modulating operation



To obtain modulating operation, the RLS/M MX series of burners requires a regulator with three point outlet controls. The following table lists the accessories for modulating operation with their application range. For remote setpoint use RWF 55.

BURNER	REGULATOR TYPE	REGULATOR CODE
▶ RLS 68/M - 120/M MX	RWF 50.2	20082208
	RWF 55.5	20099657
▶ RLS 160/M MX	RWF 50.2	20099869
	RWF 55.5	20099905

The relative temperature or pressure probes fitted to the regulator must be chosen on the basis of the application.



BURNER	PROBE TYPE	RANGE (°C) (bar)	PROBE CODE
▶ RLS/M MX	Temperature PT 100	-100 ÷ 500°C	3010110
▶ RLS/M MX	Pressure 4 ÷ 20 mA	0 ÷ 2,5 bar	3010213
▶ RLS/M MX	Pressure 4 ÷ 20 mA	0 ÷ 16 bar	3010214
▶ RLS/M MX	Pressure 4 ÷ 20 mA	0 ÷ 25 bar	3090873



Modulating operation can also be obtained with an analog control signal converter and a feedback three-pole potentiometer. Alternatively, the potentiometer can be used to check the servomotor position.

BURNER	TYPE (INPUT SIGNAL)	KIT CODE
▶ RLS 68/M - 120/M MX	0/2 - 10 V (impedance 200 KΩ)	-
	0/4 - 20 mA (impedance 250 Ω)	
▶ RS 160/M MX	0/2 - 10 V (impedance 200 KΩ)	3010415
	0/4 - 20 mA (impedance 250 Ω)	

Depending on the servomotor fitted to the burner, a three-pole potentiometer (1000 Ω) can be installed to check the position of the servomotor. The KITS available for the various burners are listed below.

BURNER	POTENTIOMETER KIT CODE
▶ RLS 68/M - 120/M - 160/M MX	3010416

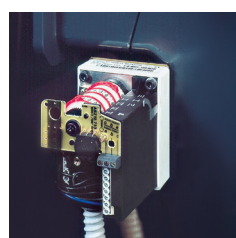

Head kit for "reverse flame chamber"



In certain cases, the use of the burner on reverse flame boilers can be improved by using an additional Pipes Kit.

BURNER	KIT CODE (*)
▶ RLS 68/M MX	20006401
▶ RLS 120/M MX	20006402
▶ RLS 160/M MX	3010249

(*) CE approval on field is required





Low NOx Modulating Dual Fuel Burners

RLS 68÷160/M MX SERIES

Gas train accessories

Adapters

When the diameter of the gas train is different from the set diameter of the burners, an adapter must be fitted between the gas train and the burner. Below are given the available adapters; please see on the Gas Train list the correct adapter codes to select.

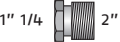
ADAPTER	LENGTH mm	ADAPTER CODE
 3/4" 1" 1/2	31	3000824
 DN 65 2" 1/2 2"	300	3000825
 2" 1/2 1" 1/2		
 DN 80 2" 1/2 2"	300	3000826
 1" 1/2 2"	35	3000843
 1" 1/4 2"	35	3010126

Stabiliser spring



Accessory springs are available to vary the pressure range of the gas train stabilisers. The following table shows these accessories with their application range. Please refer to the technical manual for the correct choice of spring.

GAS TRAIN	SPRING COLOUR	SPRING PRESSURE RANGE mbar	SPRING CODE
▶ MBC 1900/1 - 3100/1	White	4 - 20	3010381
	Red	20 - 40	3010382
	Black	40 - 80	3010383
	Green	80 - 150	3010384
▶ CB 512/1	Red	25 - 55	3010131
	Black	60 - 110	3010157
	Pink	90 - 150	3090486
▶ CB 520/1 - 525/1	Red	25 - 55	3010132
	Black	60 - 110	3010158
	Pink	100 - 150	3090487
▶ CB 5065/1 - 5080/1	Red	25 - 55	3010133
	Black	60 - 110	3010135
	Pink	100 - 150	3090456
	Grey	140 - 200	3090992

Seal control kit



To test the valve seals on the gas train, a special "seal control kit" is available. The valve seal control device is compulsory (EN 676) on gas trains to burners with a maximum output over 1200 kW. The seal control is type VPS 504.

GAS TRAIN	KIT CODE for 50 Hz operation	KIT CODE for 60 Hz operation
▶ MB/1 type	3010123	20168805
▶ MBC/1 type	3010123	20168805
▶ CB/1 type	3010123	20168805

RLS 310÷610/M MX SERIES

The RLS/M MX series of burners are characterised by a modular monoblock structure that means all necessary components can be combined in a single unit thus making installation easier, faster and, above all, more flexible.

The series covers a firing range from 1200 to 6155 kW, and it has been designed for use in hot water boilers, overheated water boilers as well as steam boilers.

Operation can be "two stage progressive" or alternatively "modulating", for both fuels, light oil and gas, with the installation of a PID logic regulator .

The mechanical cam device of regulation allows to catch up a high modulation ratio on all firing rates range. The burners can, therefore, supply with precision the demanded power, guaranteeing a high efficiency system level and the stability setting, obtaining fuel consumption and operating costs reduction.

The combustion head guarantees reduced polluting emissions. An exclusive design guarantees low sound emissions, low electrical consumption, easy use and maintenance.

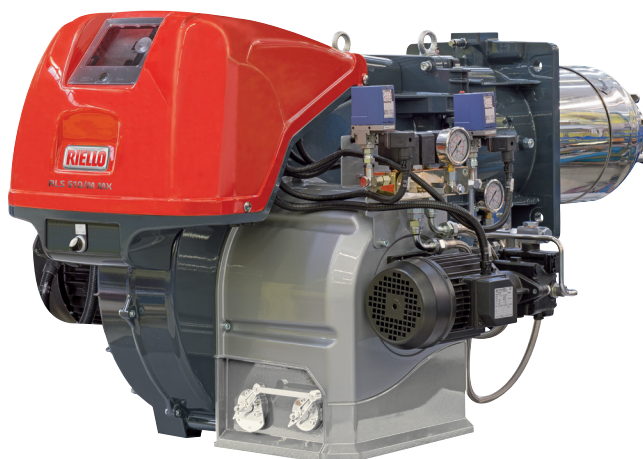

RLS 310/M MX	600/1200 ÷ 3600 kW
RLS 410/M MX	640/1500 ÷ 4200 kW
RLS 510/M MX	660/1800 ÷ 5170 kW
RLS 610/M MX	1000/2200 ÷ 6155 kW

Low NOx Modulating Dual Fuel Burners

RLS 310÷610/M MX SERIES

FIRING RATES

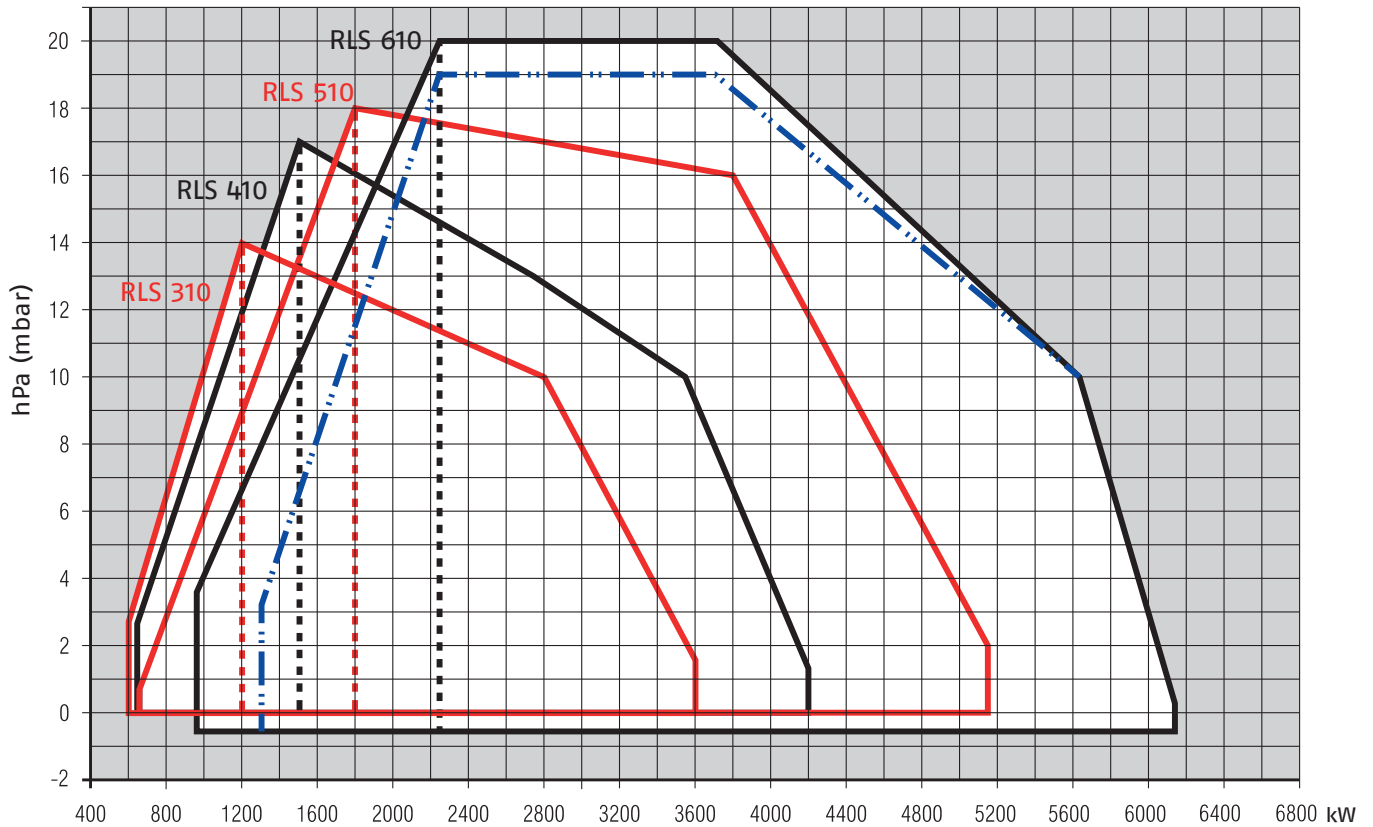

Useful working field
for choosing the
burner



Modulation range

Test conditions
conforming to EN267-
EN676

Temperature: 20°C
Pressure: 1013,5 mbar
Altitude: 0 m a.s.l.



Light-oil
firing rate
for RLS 610 model
(min. output 1.300 kW)

Overall dimensions (mm)

BURNER

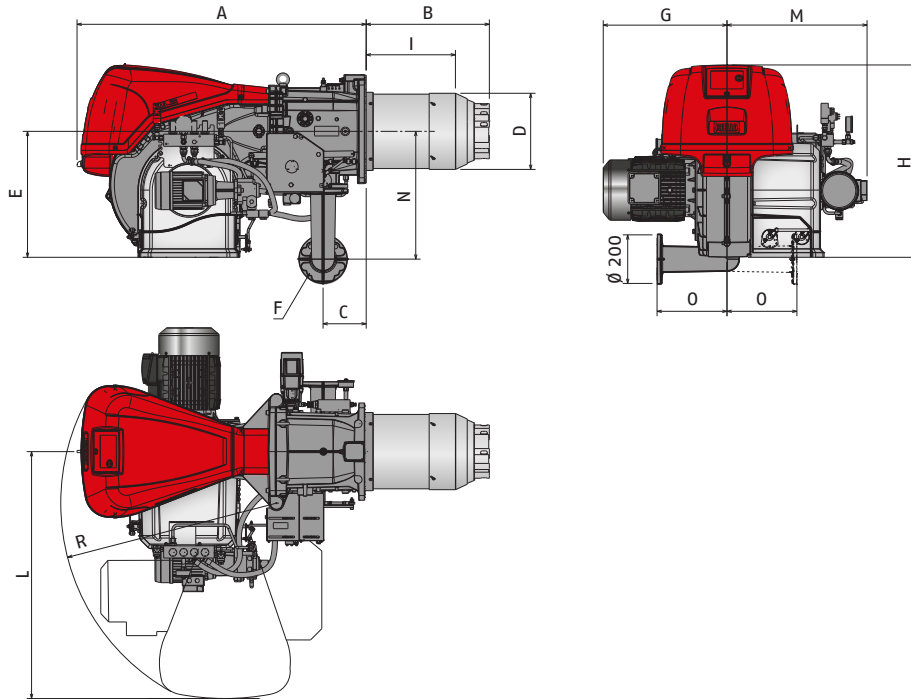

MODEL	A	B	C	D	E	F	G	H	I	L	M	N	O	R
► RLS 310/M MX	1190	507	178	313	520	DN65	571	790	365	1015	595	528	290	890
► RLS 410/M MX	1190	507	178	313	520	DN65	530	790	365	1015	595	528	290	890
► RLS 510/M MX	1190	507	178	313	520	DN65	530	790	365	1015	595	528	290	890
► RLS 610/M MX	1190	510	178	336	520	DN65	580	790	351	1015	595	528	290	890

BURNER - BOILER MOUNTING FLANGE

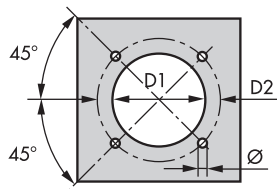

MODEL	D1	D2	Ø
► RLS 310/M MX	335	452	M18
► RLS 410/M MX	335	452	M18
► RLS 510/M MX	335	452	M18
► RLS 610/M MX	350	452	M18

PACKAGING

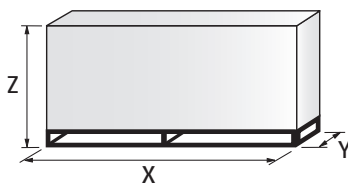

MODEL	X	Y	Z	kg
► RLS 310/M MX	2040	1180	1125	300
► RLS 410/M MX	2040	1180	1125	300
► RLS 510/M MX	2040	1180	1125	300
► RLS 610/M MX	2400	1400	1595	320

Low NOx Modulating Dual Fuel Burners

RLS 310÷610/M MX SERIES

Specification

DESIGNATION OF SERIES

Series: R

Fuel: S Natural Gas
 L Light oil
 LS Light oil/Natural Gas
 N Heavy oil

Size:

Setting: /1 Single stage
 /B Two stage
 /M Modulating-Mechanical cam
 /E Electronic cam
 /P Proportioning air/gas valve
 /EV Electronic cam predisposed for variable speed (with inverter)
 /EVi Electronic cam with integrated inverter

Emission: ... or C11 Class 1 EN267 - EN676
 MZ or C22 Class 2 EN267 - EN676
 BLU or C33 Class 3 EN267 - EN676
 MX or C23 Class 2 EN267 - Class 3 EN676
 C13 Class 1 EN267 - Class 3 EN676

Head length: TC standard head
 TL extended head

Flame control system: FS1 Standard/Intermittent (at least 1 stop every 24 h)
 FS2 Continuous (1 stop every 72 h)

Electrical supply to the system:

1/230/50	1/230V/50Hz
3/230/50	3/230V/50Hz
3/400/50	3/400V/50Hz
3/230-400/50	3/230V/50Hz - 3N/400V/50Hz
3/220/60	3/220V/60Hz
3/380/60	3N/380V/60Hz
3/220-380/60	3/220/60Hz - 3N/380V/60Hz

Auxiliary voltage: 230/50 230V/50Hz
 110/50-60 110V/50-60Hz

R	LS	310	/M	MX	TC	FS1	3/400/50	230/50
BASIC DESIGNATION					EXTENDED DESIGNATION			

RLS 310÷610/M MX SERIES

Specification

STATE OF SUPPLY

Monoblock forced draught dual fuel burners with modulating operation, fully automatic, made up of:

- High performance fan
- Air suction circuit lined with sound-proofing material
- Air damper for air setting controlled by a high precision servomotor
- Air pressure switch
- Fan starting motor at 2800 rpm, three-phase, 400V, 50Hz
- Low emission combustion head, that can be set on the basis of required output, fitted with:
 - stainless steel end cone, resistant to corrosion and high temperatures
 - ignition electrodes
 - flame stability disk
- Mechanical cam with gas and oil modulator
- Maximum gas pressure switch, with pressure test point, to stop the burner in the case of over pressure on the fuel supply line
- Flame control panel for controlling the system safety - UV flame sensor
- Star/delta starter or direct starter (RLS 310-410) for the fan motor - Main electrical supply terminal board
- Burner on/off switch
- Auxiliary voltage led signal
- Burner working led signal
- Contacts motor and thermal relay with release button
- Motor internal thermal protection
- Motor failure led signal
- Burner failure led signal and lighted release button
- Emergency button
- Coded connection plugs-sockets
- Burner opening hinge
- Lifting rings
- IP 54 electric protection level
- Light oil gears pump for high pressure fuel supply
- Dedicated pump starting motor
- Valve unit with double oil safety valve on the output circuit and double safety valve on the return circuit
- Maximum and minimum oil pressure switches
- Oil pressure gauges on supply and return oil lines
- Oil/Gas selector
- Flame inspection window.

Standard equipment:

- 1 flange gasket for gas train adaptor
- 1 adaptor for gas train
- 4 screws for fixing the flange
- 1 thermal screen
- 4 screws for fixing the burner flange to the boiler
- 2 flexible pipes for connection to the oil supply network
- 2 nipples for connection to the pump with gaskets
- 8 gas nozzles (only for RLS 310/M)
- Instruction handbook for installation, use and maintenance
- Spare parts catalogue.

Low NOx Modulating Dual Fuel Burners

RLS 310÷610/M MX SERIES

Available models

Burners

CODE	MODEL	HEAT OUTPUT			TOTAL ELECTRICAL POWER (kW)	CERTIFICATION	NOTE
		(kW)	LIGHT OIL (kg/h)	NATURAL GAS (Nm ³ /h)			
20147806	RLS 310/M MX TC FS1 3/230/50	600/1200-3600	50/100-305	60/120-360	10,9 (oil) 9,1 (gas)	CE 0085CQ0196	(1)
20147807	RLS 310/M MX TC FS1 3/400/50	600/1200-3600	50/100-305	60/120-360	10,9 (oil) 9,1 (gas)	CE 0085CQ0196	(1)
20147811	RLS 310/M MX TC FS1 3/400/50	600/1200-3600	50/100-305	60/120-360	10,9 (oil) 9,1 (gas)	CE 0085CQ0196	(1)
20147809	RLS 410/M MX TC FS1 3/230/50	640/1500-4200	55/126-352	64/150-420	12,6 (oil) 10,8 (gas)	CE 0085CQ0196	(1)
20147810	RLS 410/M MX TC FS1 3/400/50	640/1500-4200	55/126-352	64/150-420	12,6 (oil) 10,8 (gas)	CE 0085CQ0196	(1)
20147894	RLS 410/M MX TC FS1 3/400/50	640/1500-4200	55/126-352	64/150-420	12,6 (oil) 10,8 (gas)	CE 0085CQ0196	(1)
20147812	RLS 510/M MX TC FS1 3/400/50	660/1800-5170	55/195-435	66/180-517	15,8 (oil) 14 (gas)	CE 0085CQ0196	(1)
20147813	RLS 610/M MX TC FS1 3/400/50	1000/2200-6155	86/185-516	100/220-615,5	18,8 (oil) 17 (gas)	CE 0085CQ0196	(1)

Net calorific value light oil: 11,8 kWh/kg; 10.200 kcal/kg - Viscosity at 20°C: 4-6 mm²/s (cSt).

Net calorific value G20 gas: 10 kWh/Nm³; 8.600 kcal/Nm³ - Density: 0,71 kg/Nm³.

The burners of RLS/M MX series are in according to 2016/426/EU - 2014/30/EU - 2014/35/EU - 2014/68/EU - 2006/42 CE Directive and EN 267 - 676 Norm.

Due to the improvement applied on the technical specification of some products, some burner codes will change during year 2019. The table below summarizes the correspondence between the previous and the new code.

MODEL				NEW CODE	OLD CODE
RLS 310/M MX	TC	FS1	3/400/50 (delta - star)	20147811 (1)	20087651 (2)
RLS 310/M MX	TC	FS1	3/230/50 (230V direct)	20147806 (1)	20087647 (2)
RLS 310/M MX	TC	FS1	3/400/50 (400V direct)	20147807 (1)	20087648 (2)
RLS 410/M MX	TC	FS1	3/400/50 (delta - star)	20147894 (1)	20076483 (2)
RLS 410/M MX	TC	FS1	3/230/50 (230V direct)	20147809 (1)	20087649 (2)
RLS 410/M MX	TC	FS1	3/400/50 (400V direct)	20147810 (1)	20087650 (2)
RLS 510/M MX	TC	FS1	3/400/50 (delta - star)	20147812 (1)	20087652 (2)
RLS 610/M MX	TC	FS1	3/400/50 (delta - star)	20147813 (1)	20087653 (2)

Net calorific value light oil: 11,8 kWh/kg; 10.200 kcal/kg - Viscosity at 20°C: 4-6 mm²/s (cSt).

Net calorific value G20 gas: 10 kWh/Nm³; 8.600 kcal/Nm³ - Density: 0,71 kg/Nm³.

The burners of RLS/M series are in according to 2016/426/EU - 2014/30/EU - 2014/35/EU - 2006/42 CE Directive and EN 676 Norm.

(1) With RFGO control box.

(2) With LFL control box.

RLS 310÷610/M MX SERIES

Available models

Gas Trains

CODE	GAS TRAIN			VPS Code	ADAPTER CODE			
	MODEL	Ø	C.T.		RLS 310	RLS 410	RLS 510	RLS 610
3970180*	MB 415/1 - RT 30	Rp 1" 1/2	-	3010123	3000826 + 20064220	●	●	●
3970198**	MB 415/1 CT RT 30	Rp 1" 1/2	◆	-		●	●	●
3970250*	MB 415/1 - RT 52	Rp 1" 1/2	-	3010123		●	●	●
3970253**	MB 415/1 CT RT 52	Rp 1" 1/2	◆	-		●	●	●
3970232*	MB 415/1 - RSM 30	Rp 1" 1/2	-	3010123	3000826 + 20042324	●	●	●
3970181*	MB 420/1 - RT 30	Rp 2"	-	3010123		●	●	●
3970182**	MB 420/1 CT RT 30	Rp 2"	◆	-		●	●	●
3970257*	MB 420/1 - RT 52	Rp 2"	-	3010123		●	●	●
3970252**	MB 420/1 CT RT 52	Rp 2"	◆	-		●	●	●
3970233*	MB 420/1 - RSM 30	Rp 2"	-	3010123		●	●	●
3970234**	MB 420/1 CT RSM 30	Rp 2"	◆	-		●	●	●
3970221*	MBC 1200/1 - RSM 60	Rp 2"	-	3010123		3000826 + 20042324		
3970225**	MBC 1200/1 CT RSM 60	Rp 2"	◆	-	3010221			
3970222*	MBC 1900/1 - FSM 40	DN 65	-	3010123	3010222			
3970226**	MBC 1900/1 CT FSM 40	DN 65	◆	-	3010222 - 3010370			
3970223*	MBC 3100/1 - FSM 40	DN 80	-	3010123	3000826 + 20064220	●	●	
3970227**	MBC 3100/1 CT FSM 40	DN 80	◆	-		●	●	
3970224*	MBC 5000/1 - FSM 80	DN 100	-	3010123	3000826 + 20042324			
3970228**	MBC 5000/1 CT FSM 80	DN 100	◆	-	3000826 + 20042324			
3970145*	CB 512/1 - RSM 30	Rp 1" 1/2	-	3010123	3000826 + 20064220	●	●	
20045589**	CB 512/1 CT RSM 30	Rp 1" 1/2	◆	-		●	●	
3970146*	CB 520/1 - RSM 30	Rp 2"	-	3010123	3000826 + 20042324			
3970160**	CB 520/1 CT RSM 30	Rp 2"	◆	-	3000826 + 20042324			
20044659*	CB 525/1 - RSM 30	Rp 2"	-	3010123	3000826 + 20042324			
20044660**	CB 525/1 CT RSM 30	Rp 2"	◆	-	3000826 + 20042324			
3970147*	CB 5065/1 - FSM 30	DN 65	-	3010123	3010221			
3970161**	CB 5065/1 CT FSM 30	DN 65	◆	-	3010222			
3970148*	CB 5080/1 - FSM 30	DN 80	-	3010123	3010222			
3970162**	CB 5080/1 CT FSM 30	DN 80	◆	-	3010223 - 3010370			
3970149*	CB 50100/1 - FSM 30	DN 100	-	3010123	3010223 - 3010370			
3970163**	CB 50100/1 CT FSM 30	DN 100	◆	-	3010224			
20015871*	CB 50125/1 - FSM 30	DN 125	-	3010123	3010224			
3970196**	CB 50125/1 CT FSM 30	DN 125	◆	-	3010224			

Please see designation of Gas Train Series in the page before the Catalogue index.

* 230V/50Hz -220V/60Hz electrical supply.

** 230V/50Hz electrical supply.

The valve seal control device is compulsory (conforming to EN 676) on gas trains to burners with a maximum output over 1200 kW.

To select the gas train please refer to the technical data leaflet and/or instruction manual.

C.T. Gas valve leak detection control device:

- gas train not equipped with leak detection control device; this device can be ordered separately - see VPS column - and installed later.

◆ gas train equipped with leak detection control device.

VPS Valve leak detection control device. Supplied separately from the gas train (please see Gas train accessories paragraph for both 50 Hz and 60 Hz codes).

● Not available.

□ Additional adapter not necessary, the gas train may be connected directly to the burner.

Low NOx Modulating Dual Fuel Burners

RLS 310÷610/M MX SERIES

Burner accessories

Nozzles

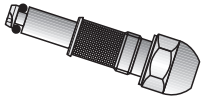

Return nozzles without needle are used on RLS/M MX burners. The nozzle must be ordered as accessory. The following table shows the features and codes on the basis of the maximum required fuel output.

BURNER	RATED DELIVERY (kg/h)	NOZZLE CODE ⁽¹⁾	NOZZLE CODE ⁽²⁾
▶ RLS 310-410/M MX	150	3009314	3045479
▶ RLS 310-410/M MX	175	3009316	3045481
▶ RLS 310-410/M MX	200	3009318	3045483
▶ RLS 310-410/M MX	225	3009320	3045485
▶ RLS 310-410-510/M MX	250	3009322	3045487
▶ RLS 310-410-510/M MX	275	3009324	3045489
▶ RLS 310-410-510-610/M MX	300	3009326	3045491
▶ RLS 310-410-510-610/M MX	325	3009328	3045493
▶ RLS 310-410-510-610/M MX	350	3009330	3045495
▶ RLS 310-410-510-610/M MX	375	3009332	3045497
▶ RLS 310-410-510-610/M MX	400	3009334	3045499
▶ RLS 310-410-510-610/M MX	425	3009336	3045500
▶ RLS 510-610/M MX	450	3009338	3045501
▶ RLS 610/M MX	475	3009340	-
▶ RLS 610/M MX	500	3009342	3045503
▶ RLS 610/M MX	525	3009344	-
▶ RLS 610/M MX	550	3009346	3045505
▶ RLS 610/M MX	575	3009348	-
▶ RLS 610/M MX	600	3009350	3045507

⁽¹⁾ Nozzle Bergonzo type B5 45° SA

⁽²⁾ Nozzle Fluidics type N2 45°

For more information please contact Riello Burners Commercial and Technical Department, our Application Engineers will be pleased to help you.

Burner accessories

Accessories for modulating operation

POWER CONTROLLER



To obtain modulating operation, the RLS/M MX series of burners requires a regulator.
For remote setpoint use RWF 55.

BURNER	REGULATOR TYPE	REGULATOR CODE
► All models	RWF 50.2 - Basic version with - 3 position output	20073595
► All models	RWF 55.5 - Complete with RS-485 interface	20074441
► All models	RWF 55.6 - Complete with RS-485/ PROFIBUS interface	20074442

PROBE



The relative temperature or pressure probes fitted to the regulator, must be chosen on the basis of the application.

BURNER	PROBE TYPE	RANGE (°C) (bar)	PROBE CODE
► All models	Temperature PT 100	-100 ÷ 500°C	3010110
► All models	Pressure 4 ÷ 20 mA	0 ÷ 2,5 bar	3010213
► All models	Pressure 4 ÷ 20 mA	0 ÷ 16 bar	3010214

ANALOG CONTROL SIGNAL CONVERTER



BURNER	TYPE (INPUT SIGNAL)	KIT CODE
► All models	0/2 - 10 V (impedance 200 KΩ) 0/4 - 20 mA (impedance 250 Ω)	20074479

POTENTIOMETER



BURNER	KIT CODE
► All models	20096322

It is necessary for analogic control signal converter operation.

Fuel remote selection kit



BURNER	KIT CODE
► All models	-

Low NOx Modulating Dual Fuel Burners

RLS 310÷610/M MX SERIES

Burner accessories

Continuous ventilation kit



If the burner requires continuous ventilation in the stages without flame, a special kit is available as given in the following table:

BURNER	KIT CODE
► All models	20074542

Sound proofing box

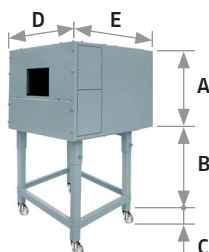

If noise emission needs reducing even further, sound-proofing boxes are available. When a lower "B" dimension is required, it is available the Box Support Kit code 20065135 which allows to reduce it at the fixed dimension of 55 mm. The sound-proofing boxes are not suitable for outdoor use.

BURNER	BOX TYPE	A (mm)	B (mm) min-max	C (mm)	D (mm)	E (mm)	[dB(A)] (*)	BOX CODE
► RLS 310-410/M	C7	1255	160 - 980	110	1140	1345	10	3010376
► RLS 510-610/M	C7 Plus	1255	160 - 980	110	1240	1345	10	20085111

(*) Average noise reduction according to EN 15036-1 standard

Spacer kit

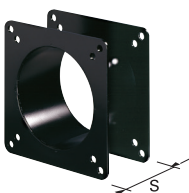



If burner head penetration into the combustion chamber needs reducing, varying thickness spacers are available, as given in the following table:

BURNER	SPACER THICKNESS S (mm)	KIT CODE
► All models	180	20008903

Gas train accessories

Adapters

In certain cases, an adapter must be fitted between the gas train and the burner, when the diameter of the gas train is different from the set diameter of the burner. Below are given the available adapters; please see on the Gas Train list the correct adapter codes to select.

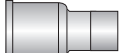
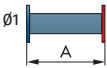
ADAPTER	DIMENSIONS				ADAPTER CODE
	Ø1 DN	Ø2 DN	A mm	B mm	
1" 1/2  2"	-	-	65	-	20064220
2"  2"	-	-	65	-	20042324
DN 80  2" 1/2  2"	-	-	300	-	3000826
	65	80	400	-	3010221
	80	80	400	-	3010222
	100	80	400	-	3010223
	125	80	320	-	3010224

Gas train accessories

Stabiliser spring



To vary the pressure range of the gas train stabilisers, accessory springs are available. The following table shows these accessories with their application range. Please refer to the technical manual for the correct choice of spring.

GAS TRAIN	SPRING COLOUR	SPRING Pressure range mbar	SPRING CODE
MBC 1900/1 - 3100/1 MBC 5000/1	White	4 - 20	3010381
	Red	20 - 40	3010382
	Black	40 - 80	3010383
CB 512/1	Green	80 - 150	3010384
	Red	25 - 55	3010131
	Black	60 - 110	3010157
CB 520/1 - 525/1	Pink	90 - 150	3090486
	Red	25 - 55	3010132
	Black	60 - 110	3010158
CB 520/1 - 525/1	Pink	100 - 150	3090487
	Red	25 - 55	3010133
	Black	60 - 110	3010135
CB 5065/1 - 5080/1	Pink	100 - 150	3090456
	Grey	140 - 200	3090992
	Red	25 - 55	3010134
CB 50100/1	Black	60 - 110	3010136
	Pink	100 - 150	3090489
	Grey	140 - 200	3092174
CB 50125/1	Red	25 - 55	3010315
	Yellow	30 - 70	3010316
	Black	60 - 110	3010317
	Pink	100 - 150	3010318

Seal control kit



To test the valve seals on the gas train, a special "seal control kit" is available. The valve seal control device is compulsory (EN 676) on gas trains to burners with a maximum output over 1200 kW.

The seal control is type VPS 504.

GAS TRAIN	Kit code for 50 Hz operation
▶ MB type	3010123
▶ MCB - CB - DMV type	3010123

RLS 800÷1200/M MX SERIES

RLS/M burners are characterised by a modular monoblock structure that means all necessary components can be combined in a single unit thus making installation easier, faster and, above all, more flexible.

The series covers a firing range from 1750 to 11500 kW, and it has been designed for use in hot water boilers, overheated water boilers as well as steam boilers.

Operation can be "two stage progressive" or alternatively "modulating", for both fuels, light oil and gas, with the installation of a PID logic regulator .

The mechanical cam device of regulation allows to catch up a high modulation ratio on all firing rates range. The burners can, therefore, supply with precision the demanded power, guaranteeing a high efficiency system level and the stability setting, obtaining fuel consumption and operating costs reduction.

The combustion head guarantees reduced polluting emissions (NOx < 80 mg/kWh on gas operation). An exclusive design guarantees low sound emissions, low electrical consumption, easy use and maintenance.



RLS 800/M MX	1750/3500 ÷ 8000 kW
RLS 1000/M MX	1200/3750 ÷ 10600 kW
RLS 1200/M MX	1500/5500 ÷ 11500 kW

Low NOx Modulating Dual Fuel Burners

RLS 800÷1200/M MX SERIES

FIRING RATES

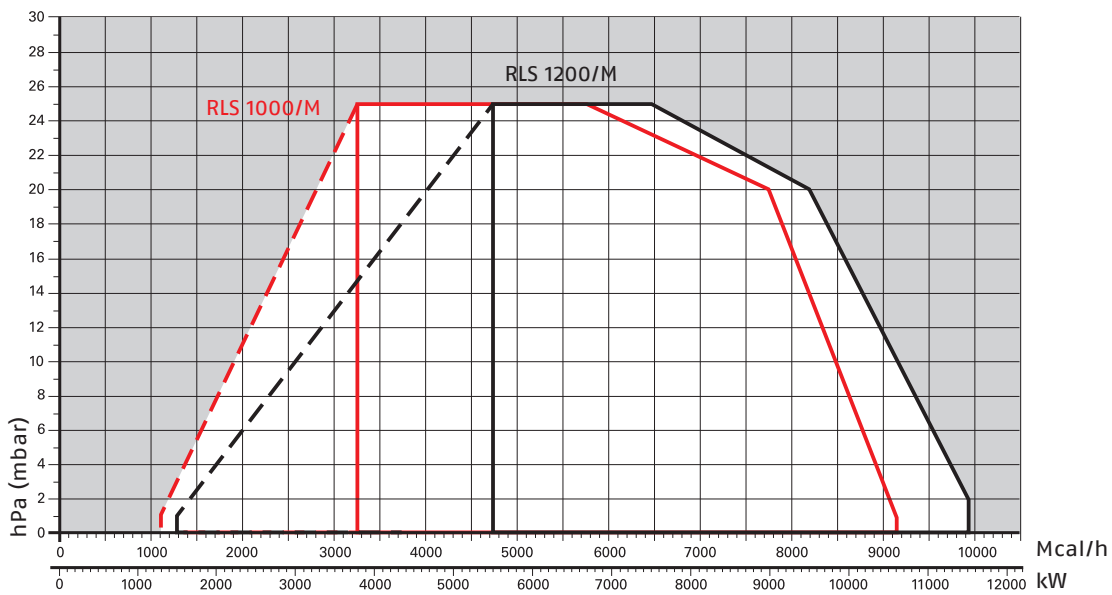
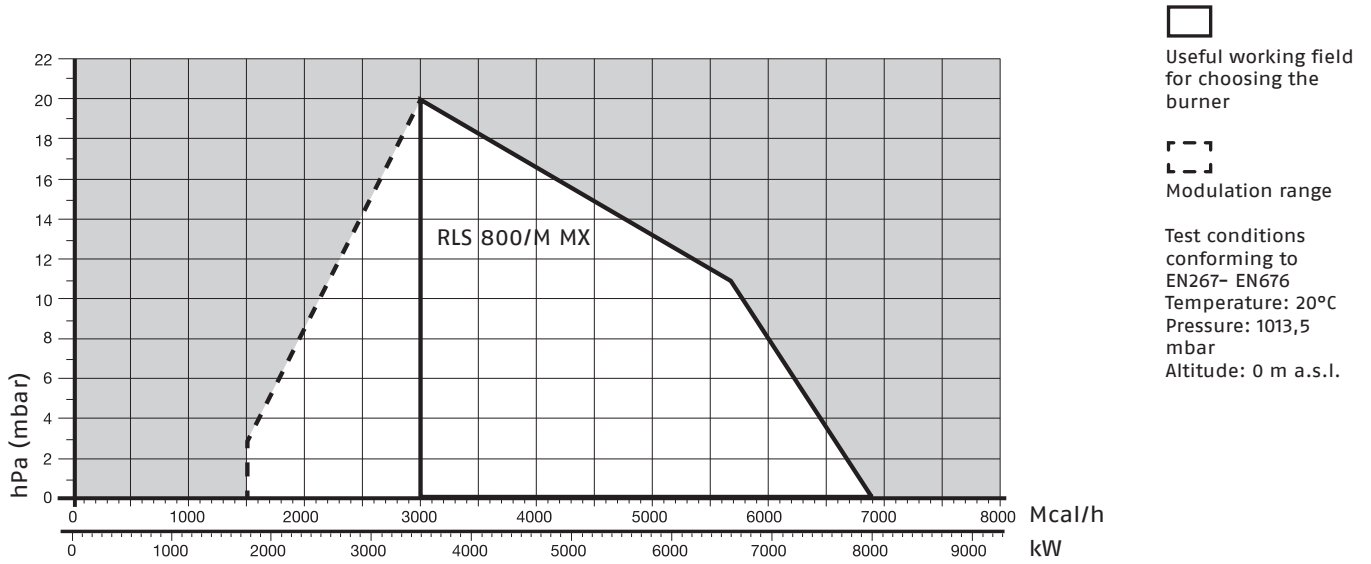

Overall dimensions (mm)

BURNER

RLS 800/M MX

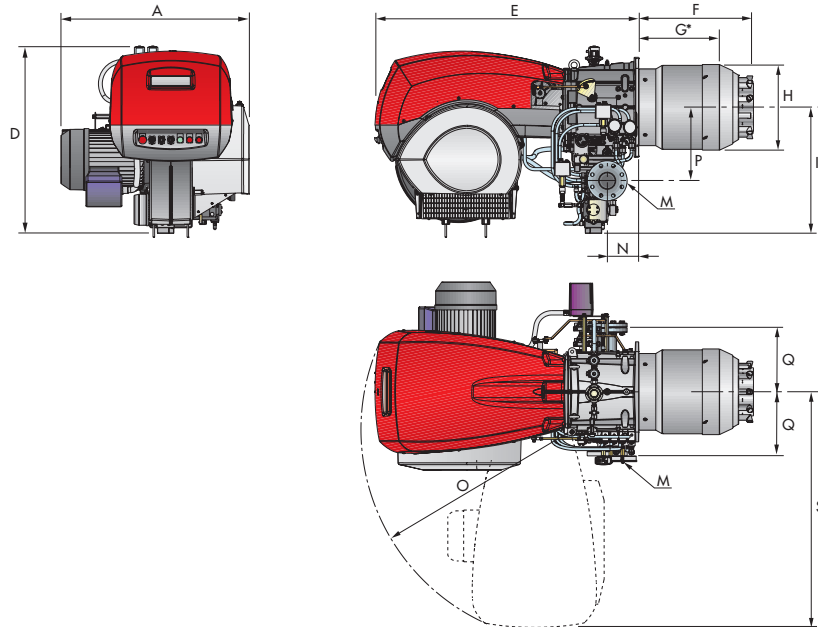

RLS 1000-1200/M MX

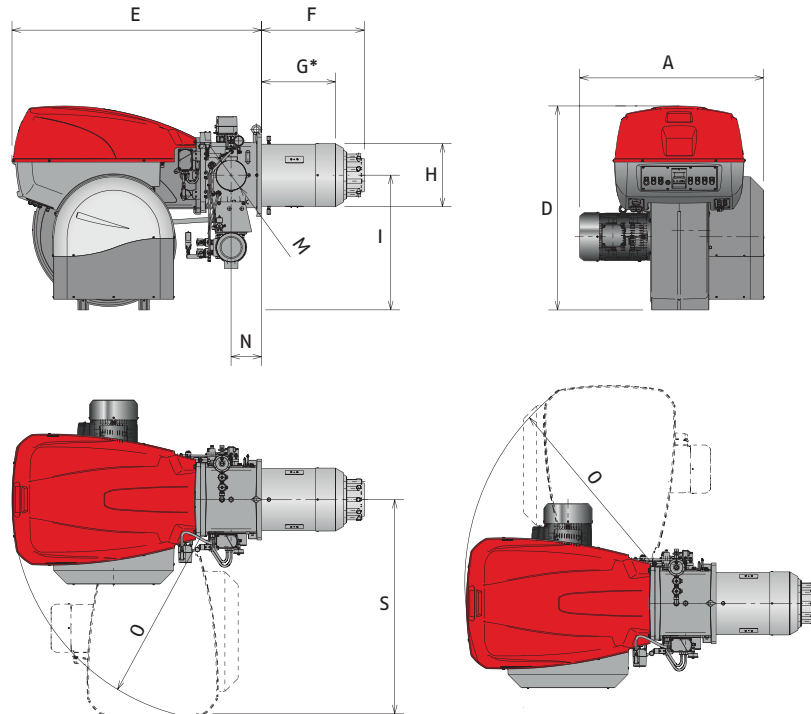

MODEL	A	D	E	F	G*	H	I	M	N	O	P	Q	S
▶ RLS 800/M MX	940	937	1325	558	382	428	630	DN80	164	1055	427	320	1190
▶ RLS 1000/M MX	1206	1338	1637	674	484	413	885	DN80	200	1350	-	-	1425
▶ RLS 1200/M MX	1250	1338	1637	658	465	456	885	DN80	200	1350	-	-	1425

* Maximum depth of the boiler door including the depth of the burner flange insulating gasket.

Low NOx Modulating Dual Fuel Burners

RLS 800÷1200/M MX SERIES

Overall dimensions (mm)

BURNER - BOILER MOUNTING FLANGE

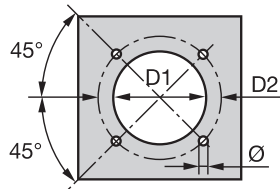

MODEL	D1	D2	Ø
▶ RLS 800/M MX	440	495	M18
▶ RLS 1000/M MX	460	608	M20
▶ RLS 1200/M MX	500	608	M20

PACKAGING

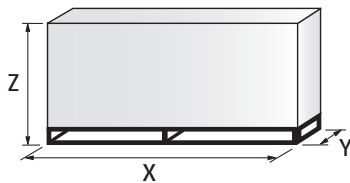

MODEL	X	Y	Z	kg
▶ RLS 800/M MX	2190	1110	1450	320
▶ RLS 1000/M MX	2400	1400	1595	550
▶ RLS 1200/M MX	2400	1400	1595	600

RLS 800÷1200/M MX SERIES

Specification

DESIGNATION OF SERIES

Series: R										
Fuel: S Natural Gas										
L Light oil										
LS Light oil/Natural Gas										
N Heavy oil										
Size:										
Setting: /1 Single stage										
/B Two stage										
/M Modulating-Mechanical cam										
/E Electronic cam										
/P Proportioning air/gas valve										
/EV Electronic cam predisposed for variable speed (with inverter)										
/EVi Electronic cam with integrated inverter										
Emission: ... or C11 Class 1 EN267 - EN676										
MZ or C22 Class 2 EN267 - EN676										
BLU or C33 Class 3 EN267 - EN676										
MX or C23 Class 2 EN267 - Class 3 EN676										
C13 Class 1 EN267 - Class 3 EN676										
Head length: TC standard head										
TL extended head										
Flame control system: FS1 Standard/Intermittent (at least 1 stop every 24 h)										
FS2 Continuous (1 stop every 72 h)										
Electrical supply to the system:										
1/230/50 1/230V/50Hz										
3/230/50 3/230V/50Hz										
3/400/50 3/400V/50Hz										
3/230-400/50 3/230V/50Hz - 3N/400V/50Hz										
3/220/60 3/220V/60Hz										
3/380/60 3N/380V/60Hz										
3/220-380/60 3/220/60Hz - 3N/380V/60Hz										
Auxiliary voltage: 230/50 230V/50Hz										
110/50-60 110V/50-60Hz										
R	LS	1200	/M	MX	TC	FS1	3/400/50	230/50		
BASIC DESIGNATION									EXTENDED DESIGNATION	

LOW NOx
DUAL FUEL

Low NOx Modulating Dual Fuel Burners

RLS 800÷1200/M MX SERIES

Specification

STATE OF SUPPLY

Monoblock forced draught dual fuel burner with modulating operation, fully automatic, made up of:

- High performance fan
- Air suction circuit lined with sound-proofing material
- Air damper for air setting controlled by a high precision servomotor
- Air pressure switch
- Fan starting motor at 2800 rpm, three-phase, 400V, 50Hz
- Low emission combustion head, that can be set on the basis of required output, fitted with:
 - stainless steel end cone, resistant to corrosion and high temperatures
 - ignition electrodes
 - ignition by gas pilot with gas train for RLS 800 - 1000 - 1200 models
 - flame stability disk
- Mechanical cam with gas and oil modulator
- Maximum gas pressure switch, with pressure test point, to stop the burner in the case of over pressure on the fuel supply line
- Flame control panel for controlling the system safety - Infrared flame detector
- Star/delta starter for the fan motor - Main electrical supply terminal board
- Burner on/off switch
- Auxiliary voltage led signal
- Burner working led signal
- Contacts motor and thermal relay with release button
- Motor internal thermal protection
- Motor failure led signal
- Burner failure led signal and lighted release button
- Emergency button
- Coded connection plugs-sockets
- Burner opening hinge
- Lifting rings
- IP 54 electric protection level
- Light oil gears pump for high pressure fuel supply
- Dedicated pump starting motor
- Valve unit with double oil safety valve on the output circuit and double safety valve on the return circuit
- Maximum an minimum oil pressure switches
- Oil pressure gauges on supply and return oil lines
- Oil/Gas selector
- Flame inspection window.
- The gas train can only enter from the left side of the burner (fan motor side)
- The RLS 1000-1200/M dual fuel burners are equipped with as spray lance for light oil, activated by compressed air.

Standard equipment:

- 1 flange gasket
- 4 screws for fixing the flange
- 1 thermal screen
- 4 screws for fixing the burner flange to the boiler
- 2 flexible pipes for connection to the oil supply network
- 2 nipples for connection to the pump with gaskets
- Seal control pressure switch (for installation on gas train)
- Instruction handbook for installation, use and maintenance
- Spare parts catalogue.

RLS 800÷1200/M MX SERIES

Available models

Burners

CODE	MODEL	HEAT OUTPUT			TOTAL ELECTRICAL POWER (kW)	CERTIFICATION
		(kW)	LIGHT OIL (kg/h)	NATURAL GAS (Nm ³ /h)		
20147802	RLS 800/M MX TC FS1 3/400/50 230/50-60	1750/3500-8000	148/295-675	175/350-800	25,8 (oil) 24 (gas)	CE-0085CLO422
20147815	RLS 1000/M MX TC FS1 3/400/50 230/50-60	1200/3750-10600	110/320-793	130/380-940	27 (oil) 24 (gas)	CE-0085CN0119
20147814	RLS 1200/M MX TC FS1 3/400/50 230/50-60	1500/5500-11500	126/464-970	150/550-1150	32 (oil) 27,2 (gas)	CE-0085CN0120

Net calorific value light oil: 11,8 kWh/kg; 10.200 kcal/kg - Viscosity at 20°C: 4-6 mm²/s (cSt).

Net calorific value G20 gas: 10 kWh/Nm³; 8.600 kcal/Nm³ - Density: 0,71 kg/Nm³.

The burners of RLS/M MX series are in according to 2016/426/EU - 2014/30/EU - 2014/35/EU - 2014/68/EU - 2006/42 CE Directive and EN 267 - 676 Norm.

Due to the improvement applied on the technical specification of some products, some burner codes will change during year 2019. The table below summarizes the correspondence between the previous and the new code.

MODEL	NEW CODE	OLD CODE
RLS 800/M MX TC FS1 3/400/50 230/50-60	20147802 (1)	3911112 (2)
RLS 1000/M MX TC FS1 3/400/50 230/50-60	20147815 (1)	20057525 (2)
RLS 1200/M MX TC FS1 3/400/50 230/50-60	20147814 (1)	20053012 (2)

Net calorific value light oil: 11,8 kWh/kg; 10.200 kcal/kg - Viscosity at 20°C: 4-6 mm²/s (cSt).

Net calorific value G20 gas: 10 kWh/Nm³; 8.600 kcal/Nm³ - Density: 0,71 kg/Nm³.

The burners of RLS/M series are in according to 2016/426/EU - 2014/30/EU - 2014/35/EU - 2006/42 CE Directive and EN 676 Norm.

(1) With RFGO control box.

(2) With LFL control box.

Gas Trains

CODE	GAS TRAIN			VPS CODE	RLS 800	RLS 1000	RLS 1200
	MODEL	Ø	C.T.				
3970221*	MBC 1200/1 - RSM 60	Rp 2"	-	3010123	3000826 + 20042324	●	●
3970225**	MBC 1200/1 CT RSM 60	Rp 2"	◆	-			
3970222*	MBC 1900/1 - FSM 40	DN 65	-	3010123	3010221 - 3010369	●	●
3970226**	MBC 1900/1 CT FSM 40	DN 65	◆	-			
3970223*	MBC 3100/1 - FSM 40	DN 80	-	3010123	3010222 (1)	●	●
3970227**	MBC 3100/1 CT FSM 40	DN 80	◆	-			
3970224*	MBC 5000/1 - FSM 80	DN 100	-	3010123	3010223 - 3010370	●	●
3970228**	MBC 5000/1 CT FSM 80	DN 100	◆	-			
20044659*	CB 525/1 - RSM 30	Rp 2"	-	3010123	3000826 + 20042324	●	●
20044660**	CB 525/1 CT RSM 30	Rp 2"	◆	-			
3970147*	CB 5065/1 - FSM 30	DN 65	-	3010123	3010221 - 3010369	●	●
3970161**	CB 5065/1 CT FSM 30	DN 65	◆	-			
3970148*	CB 5080/1 - FSM 30	DN 80	-	3010123	3010222 (1)	●	●
3970162**	CB 5080/1 CT FSM 30	DN 80	◆	-			
3970149*	CB 50100/1 - FSM 30	DN 100	-	3010123	3010223 - 3010370	●	●
3970163**	CB 50100/1 CT FSM 30	DN 100	◆	-			
20015871*	CB 50125/1 - FSM 30	DN 125	-	3010123	3010224	●	●
3970196**	CB 50125/1 CT FSM 30	DN 125	◆	-			

Please see designation of Gas Train Series in the page before the Catalogue index.

* 230V/50Hz -220V/60Hz electrical supply.

** 230V/50Hz electrical supply.

The valve seal control device is compulsory (conforming to EN 676) on gas trains to burners with a maximum output over 1200 kW.

To select the gas train please refer to the technical data leaflet and/or instruction manual.

C.T. Gas valve leak detection control device:

- gas train not equipped with leak detection control device; this device can be ordered separately - see VPS column - and installed later.

◆ gas train equipped with leak detection control device.

VPS Valve leak detection control device. Supplied separately from the gas train (please see Gas train accessories paragraph for both 50 Hz and 60 Hz codes).

(1) To use if it is necessary to space out the gas train from the burner.

● Not available.

□ Additional adapter not necessary, the gas train may be connected directly to the burner.

Low NOx Modulating Dual Fuel Burners

RLS 800÷1200/M MX SERIES

Burner accessories

Nozzles

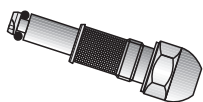

Return nozzles without needle are used on RLS/M MX burners. The nozzle must be ordered as accessory. The following table shows the features and codes on the basis of the maximum required fuel output.

BURNER	NOZZLE TYPE	RATED DELIVERY (kg/h)	NOZZLE CODE
▶ RLS 800/M MX	B5 SA 45°	375	3009332
▶ RLS 800/M MX	B5 SA 45°	550	3009346
▶ RLS 800/M MX	B5 SA 45°	650	3009352
▶ RLS 800/M MX	B5 SA 45°	750	3009356
▶ RLS 1000/M MX	B5 AA 60°	350	20047954
▶ RLS 1000/M MX	B5 AA 60°	600	20047978
▶ RLS 1000/M MX	B5 AA 60°	750	20047985
▶ RLS 1000/M MX	B5 AA 60°	900	20047994
▶ RLS 1200/M MX	CT5 60°	700	20006479
▶ RLS 1200/M MX	CT5 60°	700	20006479
▶ RLS 1200/M MX	CT5 60°	900	20006482
▶ RLS 1200/M MX	CT5 60°	1100	20006484

For more information please contact Riello Burners Commercial and Technical Department, our Application Engineers will be pleased to help you.

Accessories for modulating operation

POWER CONTROLLER



To obtain modulating operation, the RLS/M MX series of burners requires a regulator. For remote setpoint use RWF 55.

BURNER	TYPE	KIT CODE
▶ All models	RWF 50.2	20101190
▶ All models	RWF 55.5	20101191

PROBE



The relative temperature or pressure probes fitted to the regulator, must be chosen on the basis of the application.

BURNER	PROBE TYPE	RANGE (°C) (bar)	KIT CODE
▶ All models	Temperature PT 100	-100 ÷ 500°C	3010110
▶ All models	Pressure 4 ÷ 20 mA	0 ÷ 2,5 bar	3010213
▶ All models	Pressure 4 ÷ 20 mA	0 ÷ 16 bar	3010214
▶ All models	Pressure 4 ÷ 20 mA	0 ÷ 25 bar	3090873

Burner accessories

ANALOG CONTROL SIGNAL CONVERTER



BURNER	TYPE (INPUT SIGNAL)	KIT CODE
► All models	0/2 - 10 V (impedance 200 K Ω) 0/4 - 20 mA (impedance 250 Ω)	3010390

POTENTIOMETER



BURNER	KIT CODE
► RLS 800/M	3010402
► RLS 1000-1200/M	-

It is necessary for analogic control signal converter operation.

Fuel remote selection kit



BURNER	KIT CODE
► RLS 800/M	3010372

Sound proofing box

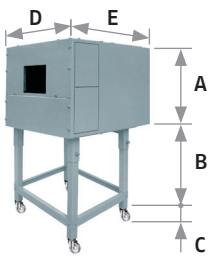

If noise emission needs reducing even further, sound-proofing boxes are available. When a lower "B" dimension is required, it is available the Box Support Kit code 20065135 which allows to reduce it at the fixed dimension of 55 mm. The sound-proofing boxes are not suitable for outdoor use.

BURNER	BOX TYPE	A (mm)	B (mm) min-max	C (mm)	D (mm)	E (mm)	[dB(A)] (*)	BOX CODE
► RLS 800/M	C7	1255	160 - 980	110	1140	1345	10	3010376
► RLS 1000-1200/M	C8	1425	285 - 1000	110	1500	1800	10	3010401

(*) Average noise reduction according to EN 15036-1 standard

Spacer kit

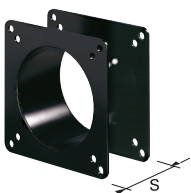

If burner head penetration into the combustion chamber needs reducing, varying thickness spacers are available, as given in the following table:

BURNER	SPACER THICKNESS S (mm)	KIT CODE
► RLS 800/M	180	20008903

Low NOx Modulating Dual Fuel Burners

RLS 800÷1200/M MX SERIES

Burner accessories

Continuous ventilation kit



If the burner requires continuous ventilation in the stages without flame, a special kit is available as given in the following table:

BURNER	KIT CODE
► RLS 1000-1200/M	20086519

Gas train accessories

Adapters

In certain cases, an adapter must be fitted between the gas train and the burner, when the diameter of the gas train is different from the set diameter of the burner. Below are given the available adapters; please see on the Gas Train list the correct adapter codes to select.

ADAPTER	DIMENSIONS					ADAPTER CODE
	Ø1 DN	Ø0 DN	A mm	B mm	C mm	
	65	80	400	-	-	3010221
	80	80	400	-	-	3010222
	100	80	400	-	-	3010223
	125	80	320	-	-	3010224
	65	80	10	-	-	3010369
	100	80	50	-	-	3010370
	-	-	35	-	-	3000843
	-	-	300	-	-	3000826
	-	-	65	-	-	20042324

RLS 800÷1200/M MX SERIES

Gas train accessories

Stabiliser spring



To vary the pressure range of the gas train stabilisers, accessory springs are available. The following table shows these accessories with their application range. Please refer to the technical manual for the correct choice of spring.

GAS TRAIN	SPRING COLOUR	SPRING PRESSURE RANGE mbar	SPRING CODE
▶ MBC 1900/1 - 3100/1 MBC 5000/1	White	4 - 20	3010381
	Red	20 - 40	3010382
	Black	40 - 80	3010383
	Green	80 - 150	3010384
▶ CB 5065/1-5080/1	Red	25 - 55	3010133
	Black	60 - 110	3010135
	Pink	100 - 150	3090456
	Grey	140 - 200	3090992
▶ CB 50100/1	Red	25 - 55	3010134
	Black	60 - 110	3010136
	Pink	100 - 150	3090489
	Grey	140 - 200	3092174
▶ CB 50125/1	Red	25 - 55	3010315
	Yellow	30 - 70	3010316
	Black	60 - 110	3010317
	Pink	100 - 150	3010318

Seal control kit



To test the valve seals on the gas train, a special "seal control kit" is available. The valve seal control device is compulsory (EN 676) on gas trains to burners with a maximum output over 1200 kW. The seal control is type VPS 504.

GAS TRAIN	KIT CODE for 50 Hz operation	KIT CODE for 60 Hz operation
▶ MBC/1 type	3010123	20168805
▶ CB/1 type	3010123	20168805

RLS 68÷200/E-/EVi MX SERIES

The RLS/E-/EVi MX series of burners covers a firing range from 350 to 2322 kW, and they have been designed for use in low or medium temperature hot water boilers, hot air or steam boilers, diathermic oil boilers.

They are equipped with Siemens LMV26, which is able to manage the air-fuel ratio by independent servomotors in order to obtain a perfect output control and to assure a correct combustion and safe operation on all modulation range. Operation can be "two stage progressive" or, alternatively, "modulating" with the installation of a PID logic regulator and respective probes.

RLS/E-/EVi MX burners series guarantees high efficiency levels in all the various applications, thus reducing fuel consumption and running costs.

The RLS/EVi MX models, are available to operate with Variable Speed Drive technology based on the control of a Frequency Inverter that modifies the air flow through the motor speed variation; they leave the factory with the inverter installed on the fan motor, already settled for the startup and ready to operate correctly without any need of additional adjustments.

Optimisation of sound emissions is guaranteed by the special design of the air suction circuit and by incorporated sound proofing material.

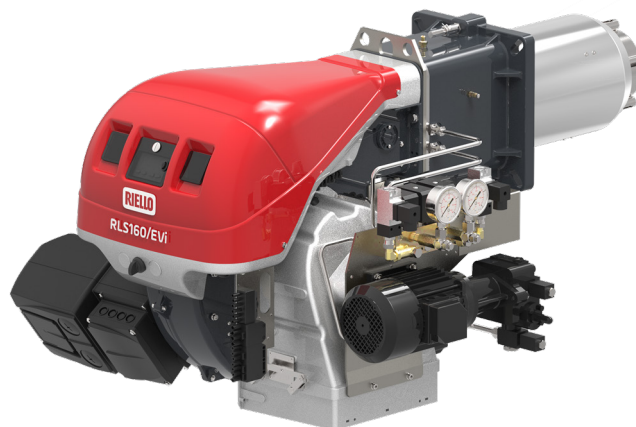

RLS 68/E-/EVi MX	195/350 ÷ 871	kW
RLS 120/E-/EVi MX	290/595 ÷ 1224	kW
RLS 160/E-/EVi MX	421/947 ÷ 1845	kW
RLS 200/E-/EVi MX	401/1400 ÷ 2322	kW

Low NOx Modulating Dual Fuel Burners

RLS 68÷200/E-/EVi MX SERIES

FIRING RATES

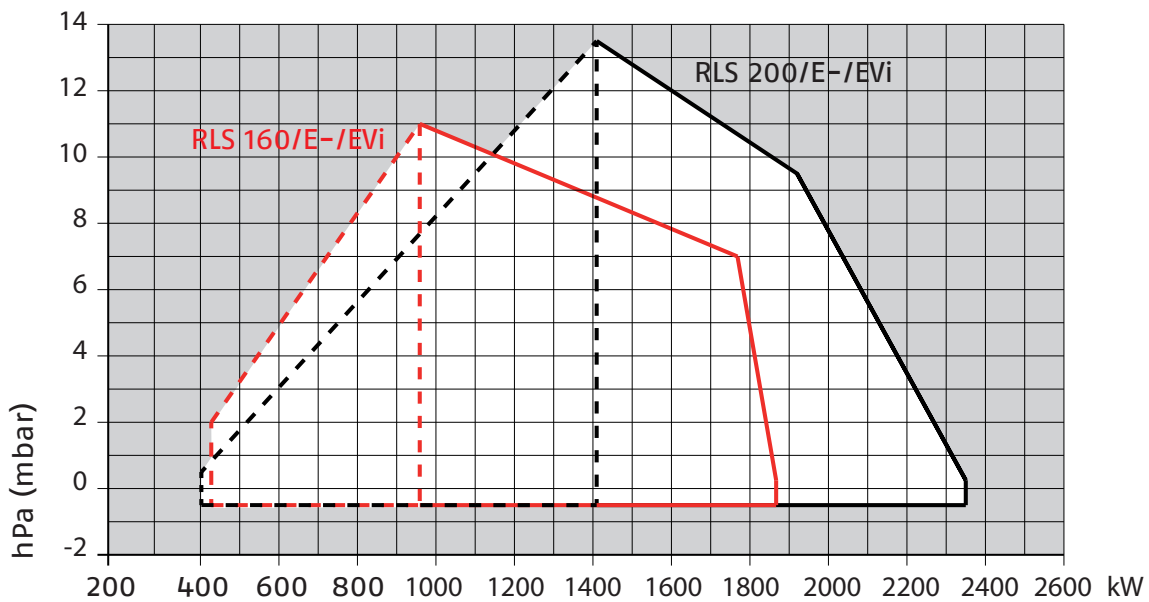
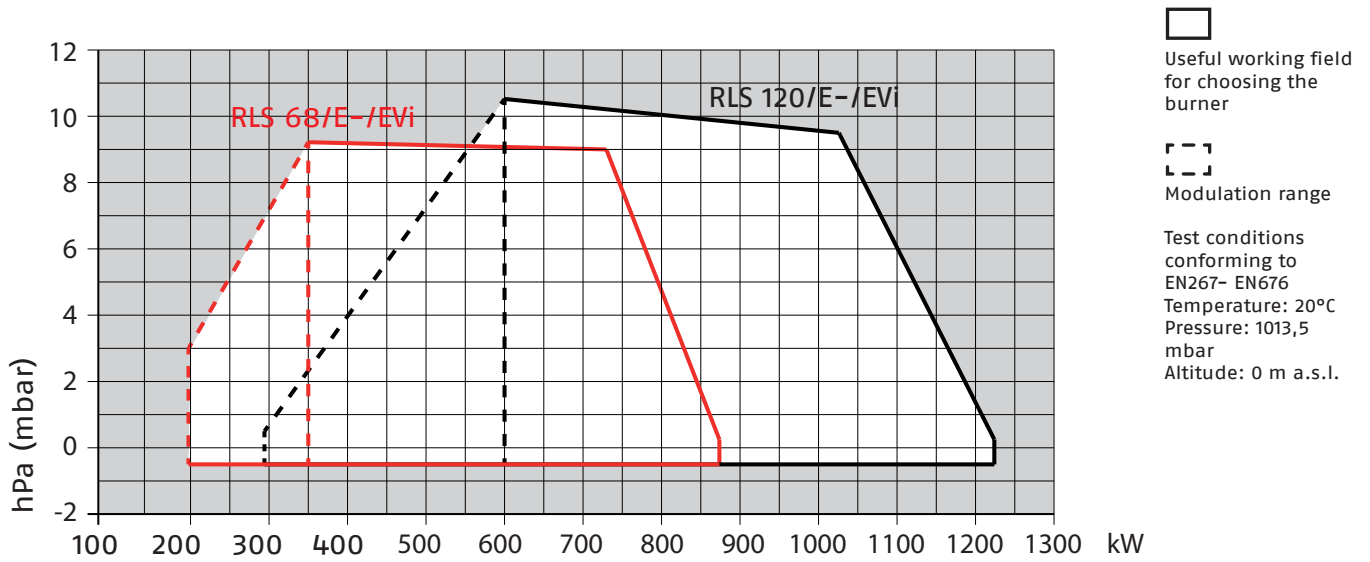

RLS 68÷200/E-/EVi MX SERIES

Overall dimensions (mm)

BURNER

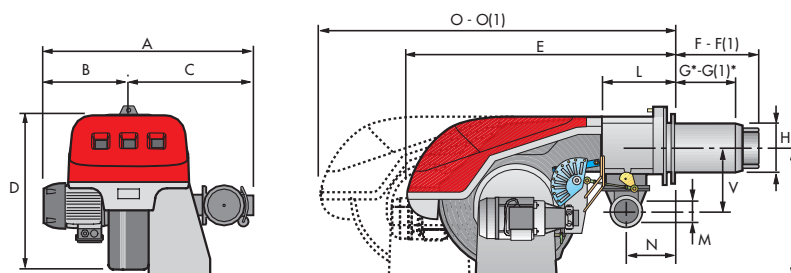

Model	A	B	C	D	E	F - F(1)	G* - G(1)*	H	I	L	M	N	O - O (1)	V
RLS 68/E-/EVi MX	745	350	395	585	860	260 - 395	200 - 335	189	430	214	2"	134	1161 - 1300	221
RLS 120/E-/EVi MX	765	370	395	585	860	260 - 395	200 - 335	189	430	214	2"	134	1161 - 1300	221
RLS 160/E-/EVi MX	895	415	480	615	880	373 - 503	272 - 402	221	445	221	2"	141	1440 - 1575	262
RLS 200/E-/EVi MX	935	455	480	615	880	373 - 503	272 - 402	221	445	221	2"	141	1440 - 1575	262

(1) Length with extended combustion head.

* Maximum depth of the boiler door including the depth of the burner flange insulating gasket.

BURNER - BOILER MOUNTING FLANGE

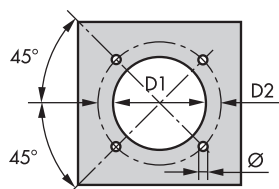

MODEL	D1	D2	Ø
▶ RLS 68-120/E-/EVi MX	195	275 - 325	M12
▶ RLS 160-200/E-/EVi MX	230	325 - 368	M16

PACKAGING

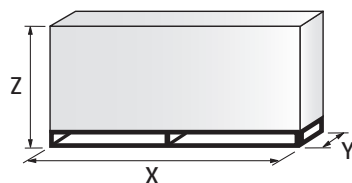

MODEL	X (1)	Y	Z	kg
▶ RLS 68/E-/EVi MX	1400	975	645	115
▶ RLS 120/E-/EVi MX	1400	975	645	120
▶ RLS 160/E-/EVi MX	1400 - 1500 (2)	975	645	135
▶ RLS 200/E-/EVi MX	1400 - 1500 (2)	975	645	135

(1) Length with standard and extended combustion head.

(2) Length with extended combustion head.

Low NOx Modulating Dual Fuel Burners

RLS 68÷200/E-/EVi MX SERIES

Specification

DESIGNATION OF SERIES

Series: R									
Fuel: S Natural Gas									
L Light oil									
LS Light oil/Natural Gas									
N Heavy oil									
Size:									
Setting: /1 Single stage									
/B Two stage									
/M Modulating-Mechanical cam									
/E Electronic cam									
/P Proportioning air/gas valve									
/EV Electronic cam predisposed for variable speed (with inverter)									
/EVi Electronic cam with integrated inverter									
Emission: ... or C11 Class 1 EN267 - EN676									
MZ or C22 Class 2 EN267 - EN676									
BLU or C33 Class 3 EN267 - EN676									
MX or C23 Class 2 EN267 - Class 3 EN676									
C13 Class 1 EN267 - Class 3 EN676									
Head length: TC standard head									
TL extended head									
Flame control system: FS1 Standard/Intermittent (at least 1 stop every 24 h)									
FS2 Continuous (1 stop every 72 h)									
Electrical supply to the system:									
1/230/50 1/230V/50Hz									
3/230/50 3/230V/50Hz									
3/400/50 3/400V/50Hz									
3/230-400/50 3/230V/50Hz - 3N/400V/50Hz									
3/220/60 3/220V/60Hz									
3/380/60 3N/380V/60Hz									
3/220-380/60 3/220/60Hz - 3N/380V/60Hz									
Auxiliary voltage: 230/50 230V/50Hz									
110/50-60 110V/50-60Hz									
R	LS	160	/EVi	MX	TC	FS1	3/400/50	230/50	
BASIC DESIGNATION				EXTENDED DESIGNATION					

RLS 68÷200/E-/EVi MX SERIES

Specification

STATE OF SUPPLY

Monoblock forced draught Low NOx dual fuel burner with two stage progressive or modulating operation at the gas and oil side, with a specific kit, fully automatic, made up of:

- air suction circuit lined with sound-proofing material
- centrifugal fan with high performance and low sound emissions
- air damper for air flow setting controlled by a high precision servomotor
- starting motor at 2800 rpm, three-phase 400V with neutral, 50Hz
- Fan motor with installed Frequency Inverter to modify the air flow, on the RLS/EVi MX models
- low emission combustion head, that can be set on the basis of required output, fitted with:
 - stainless steel end cone, resistant to corrosion and high temperatures
 - ignition electrodes
 - gas distributor
 - flame stability disk
- maximum gas pressure switch to stop the burner in the case of excess pressure on the fuel supply line
- minimum air pressure switch stops the burner in case of insufficient air quantity at the combustion head
- gears pump for high pressure fuel supply
- pump starting motor
- oil safety valves
- flame control panel
- UV photocell for flame detection
- burner on/off selection switch
- oil/gas selector
- flame inspection window
- slide bars for easier installation and maintenance
- protection filter against radio interference
- IP 44 electric protection level.
- digital Burner management system for air/fuel setting; with output PID modulation control as accessory
- AZL Display Interface, for combustion system commissioning and monitoring
- electronic cam for controlling the system safety
- valve unit with double oil safety valve on the output circuit and a safety valve on the return circuit (RLS 68/E-/EVi MX); double oil safety valve on the return circuit (RLS 120-160-200/E-/EVi MX)

Standard equipment:

- 1 gas train flange
- 1 flange gasket
- 4 screws for fixing the flange
- 1 thermal screen
- 4 screws for fixing the burner flange to the boiler
- 2 flexible pipes for connection to the oil supply network
- 2 nipples for connection to the pump with gaskets
- Instruction handbook for installation, use and maintenance
- Spare parts catalogue

Low NOx Modulating Dual Fuel Burners

RLS 68÷200/E-/EVi MX SERIES

Available models

Burners

CODE	MODELS					HEAT OUTPUT			TOTAL ELECTRICAL POWER (W)	NOTE
						(kW)	LIGHT OIL (kg/h)	NATURAL GAS (Nm ³ /h)		
20073915	RLS 68/E MX	TC	FS1	3/230-400/50	230/50-60	195/350-871	16/29-73	20/35-87	1880 (oil) 1800 (gas)	(1)
20073918	RLS 120/E MX	TC	FS1	3/230-400/50	230/50-60	290/595-1224	24/50-95	29/60-123	2588 (oil) 2588 (gas)	(1)
20073920	RLS 160/E MX	TC	FS1	3/400/50	230/50-60	421/947-1845	35/80-155	42/95-185	6646 (oil) 5249 (gas)	(1)
20081721	RLS 200/E MX	TC	FS1	3/400/50	230/50-60	401/1400-2322	34/118-96	40/140-232	7705 (oil) 6638 (gas)	(1)
20070471	RLS 68/EVi MX	TC	FS1	3/400/50	230/50-60	195/350-871	16/29-73	20/35-87	1880 (oil) 1800 (gas)	(1)
20070476	RLS 120/EVi MX	TC	FS1	3/400/50	230/50-60	290/595-1224	24/50-95	29/60-123	2588 (oil) 2588 (gas)	(1)
20070482	RLS 160/EVi MX	TC	FS1	3/400/50	230/50-60	421/947-1845	35/80-155	42/95-185	6646 (oil) 5249 (gas)	(1)
20081715	RLS 200/EVi MX	TC	FS1	3/400/50	230/50-60	401/1400-2322	34/118-96	40/140-232	7705 (oil) 6638 (gas)	(1)

Net calorific value light oil: 11,8 kWh/kg; 10.200 kcal/kg - Viscosity at 20°C: 4-6 mm²/s (cSt).

Net calorific value G20 gas: 10 kWh/Nm³; 8.600 kcal/Nm³ - Density: 0,71 kg/Nm³.

The burners of RLS/E-/EVi MX series are in according to 2014/30/EU - 2014/35/EU 2006/42/CE Directives.

Before using EMI filter and ferrite kit, verify the installation or contact Riello Burners Commercial and Technical Department.

(1) with plug & socket

RLS 68÷200/E-/EVi MX SERIES

Available models

Gas Trains

CODE	GAS TRAIN MODEL	ADAPTER CODE			
		RLS 68	RLS 120	RLS 160	RLS 200
3970599	MB 407/1 - RT 52	3000824 + 3000843	●	●	●
3970553	MB 407/1 - RT 20		●	●	●
3970229	MB 407/1 - RSM 20		●	●	●
3970258	MB 410/1 - RT 52	3010126		●	●
3970554	MB 410/1 - RT 20	3000824 + 3000843		●	●
3970600	MB 410/1 - RT 52			●	●
3970230	MB 410/1 - RSM 20			●	●
3970256	MB 412/1 - RT 52	3000843			●
3970144	MB 412/1 - RT 20				●
3970231	MB 412/1 - RSM 20				●
3970180	MB 415/1 - RT 30	3000843			
3970250	MB 415/1 - RT 52				
3970232	MB 415/1 - RSM 30				
3970181	MB 420/1 - RT 30	-	-	-	-
3970257	MB 420/1 - RT 52	-	-	-	-
3970233	MB 420/1 - RSM 30	-	-	-	-
3970221	MBC 1200/1 - RSM 60	-	-	-	-
3970222	MBC 1900/1 - FSM 40	3000825			
3970223	MBC 3100/1 - FSM 40	3000826			
3970145	CB 512/1 - RSM 30	3000843			
3970146	CB 520/1 - RSM 30	-	-	-	-
20044659	CB 525/1 - RSM 30	-	-	-	-
3970147	CB 5065/1 - FSM 30	3000825			
3970148	CB 5080/1 - FSM 30	3000826			
3970149	CB 50100/1 - FSM 30	3010370 + 3000826			
20015871	CB 50125/1 - FSM 30	●	3010224 + 3000826		
20043035	DMV 512/1 - RSM -0	3000843			
20043038	DMV 520/1 - RSM -0	-	-	-	-
20043053	DMV 525/1 - RSM -0	-	-	-	-
20043041	DMV 5065/1 - FSM -0	3000825			
20043044	DMV 5080/1 - FSM -0	3000826			
20043047	DMV 50100/1 - FSM -0	3010370 + 3000826			
20043050	DMV 50125/1 - FSM -0	●	●	3010224 + 3000826	

Please see designation of Gas Train Series in the page before the Catalogue index.

* 230V/50Hz -220V/60Hz electrical supply.

** 230V/50Hz electrical supply.

The valve seal control device is compulsory (conforming to EN 676) on gas trains to burners with a maximum output over 1200 kW.

To select the gas train please refer to the technical data leaflet and/or instruction manual.

C.T. Gas valve leak detection control device:

- gas train not equipped with leak detection control device; this device can be ordered separately - see VPS column - and installed later.

VPS Valve leak detection control device. Supplied separately from the gas train (please see Gas train accessories paragraph for both 50 Hz and 60 Hz codes).

● Not available.

□ Additional adapter not necessary, the gas train may be connected directly to the burner.

Low NOx Modulating Dual Fuel Burners

RLS 68÷200/E-/EVi MX SERIES

Burner accessories

Nozzles type 60° B



The nozzles must be ordered separately. The following table shows the features and codes on the basis of the maximum required fuel output.

NOTE: each burner needs N° 1 nozzle.

BURNER	RATED OUTPUT kg/h	A3 NOZZLE CODE	A4 NOZZLE CODE
▶ RLS/EVi MX	40	3009853	20067277
▶ RLS/EVi MX	50	3009854	20067279
▶ RLS/EVi MX	60	3009855	20067281
▶ RLS/EVi MX	70	3009856	20067283
▶ RLS/EVi MX	80	3009857	20067284
▶ RLS/EVi MX	90	3009858	20067285
▶ RLS/EVi MX	100	3009859	20067286
▶ RLS/EVi MX	110	3009860	20067287
▶ RLS/EVi MX	120	3009861	20067288
▶ RLS/EVi MX	130	3009862	20067289
▶ RLS/EVi MX	140	3009863	20067290
▶ RLS/EVi MX	150	20059496*	20067291
▶ RLS/EVi MX	160	3009864	20067293
▶ RLS/EVi MX	180	3009865	20067295
▶ RLS/EVi MX	200	3009866	20067297

* 60° Angle

Burner accessories

Extended head kit

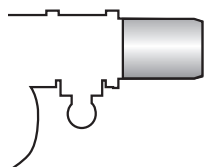

“Standard head” burners can be transformed into “extended head” versions, by using the special kit. The kits available for the various burners, giving the original and the extended lengths, are listed below.

BURNER	STANDARD HEAD LENGTH (mm)	EXTENDED HEAD LENGTH (mm)	KIT CODE
▶ RLS 68-120/E-/EVi MX	260	395	-
▶ RLS 160/E-/EVi MX	373	503	-
▶ RLS 200/E-/EVi MX	373	503	-

Burner accessories

Spacer kit



If burner head penetration into the combustion chamber needs reducing, varying thickness spacers are available, as given in the following table:

BURNER	SPACER THICKNESS S (mm)	KIT CODE
▶ RLS/E-/EVi MX	102	3000722

Continuous ventilation kit



If the burner requires continuous ventilation in the stages without flame, a special kit is available as given in the following table.

BURNER	KIT CODE
▶ RLS/E-/EVi MX	3010094

Ground fault interrupter kit



A "Ground fault interrupter kit" is available as a safety device for electrical system fault.

BURNER	KIT CODE
▶ RLS/EVi MX	20098337

Sound proofing box

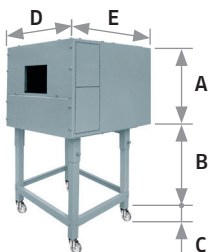

If noise emission needs reducing even further, sound-proofing boxes are available. When a lower "B" dimension is required, it is available the Box Support Kit code 20065135 which allows to reduce it at the fixed dimension of 55 mm. The sound-proofing boxes are not suitable for outdoor use.

BURNER	BOX TYPE	A (mm)	B (mm) min-max	C (mm)	D (mm)	E (mm)	[dB(A)] (*)	BOX CODE
▶ RLS 68-120/E-/EVi MX RLS 160-200/E-/EVi MX	C4/5	850	160 - 980	110	980	930	10	3010404

(*) Average noise reduction according to EN 15036-1 standard

OCI412 interface kit



Interface kit between the LMV 26 and a Modbus system, such as a building automation and control system (BACS). The Modbus interface is based on the RS-485 standard.

BURNER	KIT CODE
▶ RLS/E-/EVi MX	3010437

Low NOx Modulating Dual Fuel Burners

RLS 68÷200/E-/EVi MX SERIES

Burner accessories

Accessories for modulating operation



To obtain modulating operation, the RLS/E-EV MX series of burners requires a regulator with three point outlet controls. The following table lists the accessories for modulating operation with their application range. For remote setpoint use RWF 55.

BURNER	REGULATOR TYPE	REGULATOR CODE
▶ RLS/E-/EVi MX	RWF 50.2	20099869
	RWF 55.5	20099905

The relative temperature or pressure probes fitted to the regulator must be chosen on the basis of the application.

BURNER	PROBE TYPE	RANGE (°C) (bar)	PROBE CODE
▶ RLS/E-/EVi MX	Temperature PT 100	-100 ÷ 500°C	3010110
▶ RLS/E-/EVi MX	Pressure 4 ÷ 20 mA	0 ÷ 2,5 bar	3010213
▶ RLS/E-/EVi MX	Pressure 4 ÷ 20 mA	0 ÷ 16 bar	3010214
▶ RLS/E-/EVi MX	Pressure 4 ÷ 20 mA	0 ÷ 25 bar	3090873

Head kit for “reverse flame chamber”



In certain cases, the use of the burner on reverse flame boilers can be improved by using an additional Pipes Kit.

BURNER	KIT CODE (*)
▶ RLS 68/E-/EVi MX	20006401
▶ RLS 120/E-/EVi MX	20006402
▶ RLS 160/E-/EVi MX	3010249
▶ RLS 200/E-/EVi MX	20035848

(*) CE approval on field is required

PC Interface kit



To connect the control box to a personal computer for the transmission of operation, fault signals and detailed service information, an interface adapter with PC software are available.

BURNER	KIT CODE
▶ RLS/E-/EVi MX	3010436

EMI Filter and Ferrite

The KIT is required in case of Residential installations with direct connection in a public network (according to EN55014-1). NOT required in case of Industrial installations with connection in a dedicated network (according to EN61000-6-4).









BURNER	KIT CODE
▶ RLS 68-120/E-/EVi MX	20122917
▶ RLS 160-200/E-/EVi MX	20122922

RLS 68÷200/E-/EVi MX SERIES

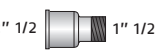
Gas train accessories

Adapters

When the diameter of the gas train is different from the set diameter of the burners, an adapter must be fitted between the gas train and the burner. Below are given the available adapters; please see on the Gas Train list the correct adapter codes to select.

ADAPTER	LENGTH mm	ADAPTER CODE
 3/4" 1" 1/2	31	3000824
 DN 65 2" 1/2	300	3000825
 2" 1/2 1" 1/2		
 DN 80 2" 1/2	300	3000826
 1" 1/2 2"	35	3000843
 1" 1/4 2"	35	3010126
 DN 100 DN 80	50	3010370
	320	3010224

Stabiliser spring



Accessory springs are available to vary the pressure range of the gas train stabilisers. The following table shows these accessories with their application range. Please refer to the technical manual for the correct choice of spring.

GAS TRAIN	SPRING COLOUR	SPRING PRESSURE RANGE mbar	SPRING CODE
▶ MBC 1900/1 – 3100/1 MBC 5000/1	White	4 – 20	3010381
	Red	20 – 40	3010382
	Black	40 – 80	3010383
	Green	80 – 150	3010384
▶ CB 512/1	Red	25 – 55	3010131
	Black	60 – 110	3010157
	Pink	90 – 150	3090486
▶ CB 520/1 – 525/1	Red	25 – 55	3010132
	Black	60 – 110	3010158
	Pink	100 – 150	3090487
▶ CB 5065/1 – 5080/1	Red	25 – 55	3010133
	Black	60 – 110	3010135
	Pink	100 – 150	3090456
	Grey	140 – 200	3090992
▶ CB 50100/1	Red	25 – 55	3010134
	Black	60 – 110	3010136
	Pink	100 – 150	3090489
	Grey	140 – 200	3092174
▶ CB 50125/1	Red	25 – 55	3010315
	Yellow	30 – 70	3010316
	Black	60 – 110	3010317
	Pink	100 – 150	3010318

Low NOx Modulating Dual Fuel Burners

RLS 68÷200/E-/EVi MX SERIES

Gas train accessories

PVP (Pressure Valve Proving) kit *

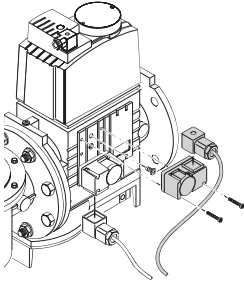

The seal control function is included on Burner Digital Management System, it is only necessary to add the PVP kit on the gas train.
The PVP is included as standard equipment on RLS 120/E-EVi-160/E-EVi-200/E-EVi MX models.

BURNER	KIT CODE
► MB - CB - MBC type	3010344

* not necessary for the RLS 120/E-EVi - 160/E-EVi - 200/E-EVi MX models where is included as a standard.

RLS 310÷610/E MX SERIES

The RLS/E-MX series of burners are characterised by a modular monoblock structure that means all necessary components can be combined in a single unit thus making installation easier, faster and, above all, more flexible.

The series covers a firing range from 1200 to 6155 kW, and they have been designed for use in hot water boilers, overheated water boilers as well as steam boilers. They are equipped with Siemens LMV26, which is able to manage the air-fuel ratio by independent servomotors in order to obtain a perfect output control and to assure a correct combustion and safe operation on all modulation range. Operation can be "two stage progressive" or alternatively "modulating" for both fuels, light oil and gas, with the installation of a PID logic regulator. The burner can, therefore, supply with precision the demanded power, guaranteeing an high efficiency system level and the stability setting, obtaining fuel consumption and operating costs reduction.

The combustion head guarantees reduced polluting emissions. An exclusive design guarantees low sound emissions, low electrical consumption, easy use and maintenance.

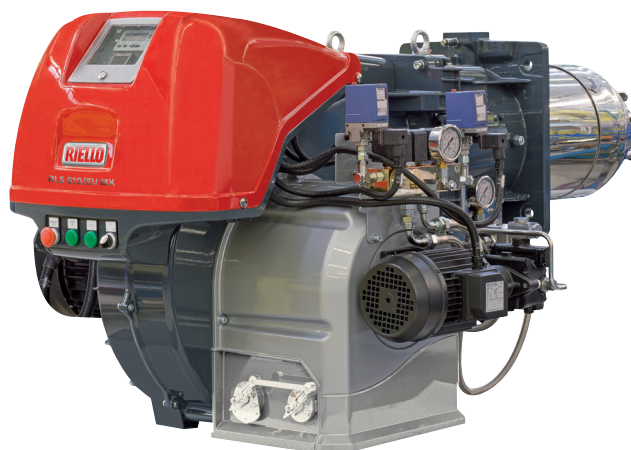

RLS 310/E MX	600/1200 ÷ 3600 kW
RLS 410/E MX	640/1500 ÷ 4200 kW
RLS 510/E MX	660/1800 ÷ 5170 kW
RLS 610/E MX	1000/2200 ÷ 6155 kW

Low NOx Modulating Dual Fuel Burners

RLS 310÷610/E MX SERIES

FIRING RATES

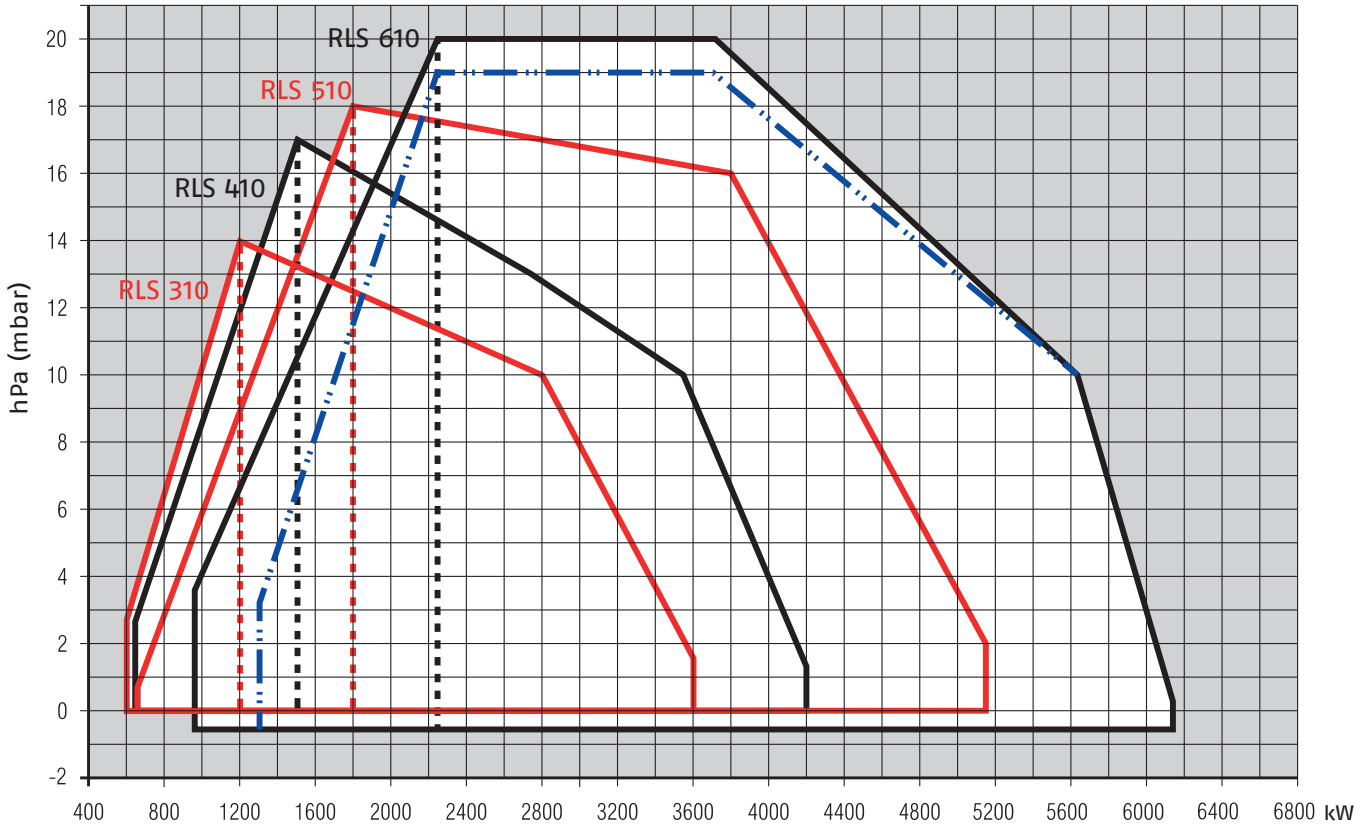

Useful working field
for choosing the
burner



Modulation range

Test conditions
conforming to EN267-
EN676

Temperature: 20°C
Pressure: 1013,5 mbar
Altitude: 0 m a.s.l.



Light-oil
firing rate
for RLS 610 model
(min. output 1.300 kW)

RLS 310÷610/E MX SERIES

Overall dimensions (mm)

BURNER

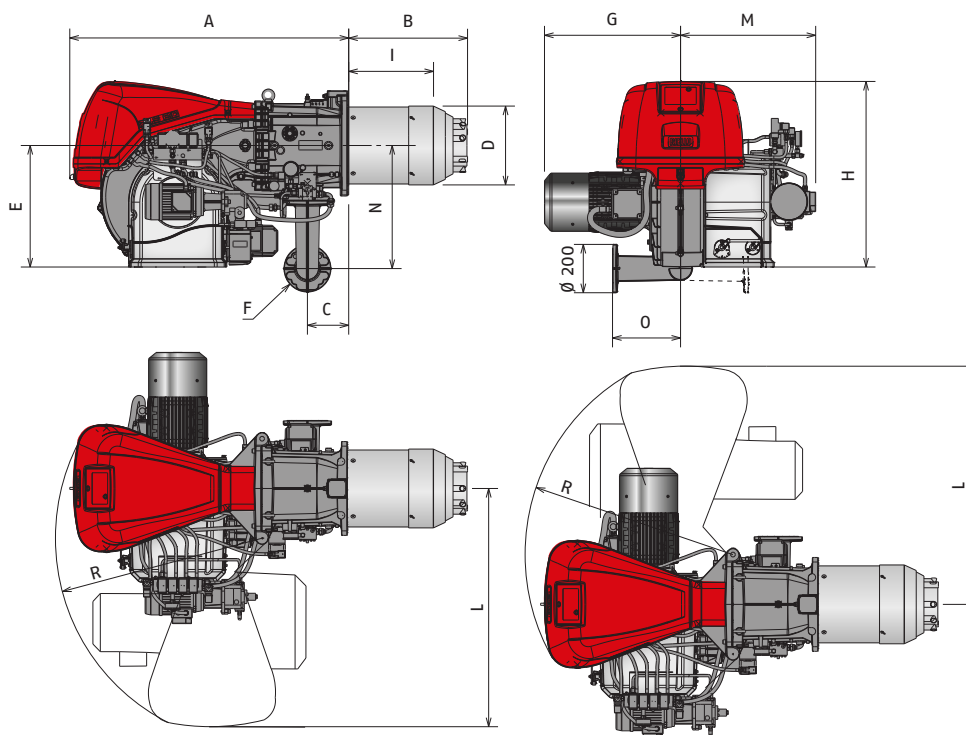

MODEL	A	B	C	D	E	F	G	H	I	L	M	N	O	R
▶ RLS 310/E MX	1190	507	178	313	520	DN65	571	790	365	1015	595	528	290	890
▶ RLS 410/E MX	1190	507	178	313	520	DN65	530	790	365	1015	595	528	290	890
▶ RLS 510/E MX	1190	507	178	313	520	DN65	530	790	365	1015	595	528	290	890
▶ RLS 610/E MX	1190	510	178	336	520	DN65	580	790	351	1015	595	528	290	890

BURNER - BOILER MOUNTING FLANGE

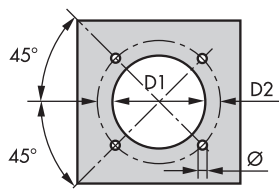

MODEL	D1	D2	Ø
▶ RLS 310/E MX	335	452	M18
▶ RLS 410/E MX	335	452	M18
▶ RLS 510/E MX	335	452	M18
▶ RLS 610/E MX	350	452	M18

PACKAGING

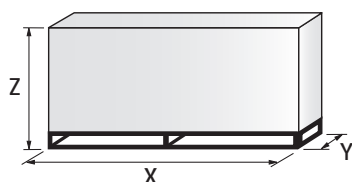

MODEL	X	Y	Z	kg
▶ RLS 310/E MX	2040	1180	1125	300
▶ RLS 410/E MX	2040	1180	1125	300
▶ RLS 510/E MX	2040	1180	1125	300
▶ RLS 610/E MX	2400	1400	1595	320

LOW NOx
DUAL FUEL

Low NOx Modulating Dual Fuel Burners

RLS 310÷610/E MX SERIES

Specification

DESIGNATION OF SERIES

Series: R

Fuel: S Natural Gas
 L Light oil
 LS Light oil/Natural Gas
 N Heavy oil

Size:

Setting: /1 Single stage
 /B Two stage
 /M Modulating-Mechanical cam
 /E Electronic cam
 /P Proportioning air/gas valve
 /EV Electronic cam predisposed for variable speed (with inverter)
 /EVi Electronic cam with integrated inverter

Emission: ... or C11 Class 1 EN267 – EN676
 MZ or C22 Class 2 EN267 – EN676
 BLU or C33 Class 3 EN267 – EN676
 MX or C23 Class 2 EN267 – Class 3 EN676
 C13 Class 1 EN267 – Class 3 EN676

Head length: TC standard head
 TL extended head

Flame control system: FS1 Standard/Intermittent (at least 1 stop every 24 h)
 FS2 Continuous (1 stop every 72 h)

Electrical supply to the system:

1/230/50	1/230V/50Hz
3/230/50	3/230V/50Hz
3/400/50	3/400V/50Hz
3/230-400/50	3/230V/50Hz – 3N/400V/50Hz
3/220/60	3/220V/60Hz
3/380/60	3N/380V/60Hz
3/220-380/60	3/220/60Hz – 3N/380V/60Hz

Auxiliary voltage: 230/50	230V/50Hz
110/50-60	110V/50-60Hz

R	LS	310	/E	MX	TC	FS1	3/400/50	230/50
---	----	-----	----	----	----	-----	----------	--------

BASIC DESIGNATION

EXTENDED DESIGNATION

RLS 310÷610/E MX SERIES

Specification

STATE OF SUPPLY

Monoblock forced draught dual fuel burners with modulating operation, fully automatic, made up of:

- High performance fan with low sound emissions, forward curve blades
- Air suction circuit lined with sound-proofing material
- Air damper for air setting controlled by a high precision servomotor
- Air pressure switch
- Fan starting motor at 2800 rpm, three-phase 230/400 - 400/690 V with neutral, 50Hz
- Separate light oil pump
- Low emission combustion head, that can be set on the basis of required output, fitted with:
 - stainless steel end cone, resistant to corrosion and high temperatures
 - ignition electrodes
 - flame stability disk
- Maximum gas pressure switch, with pressure test point, for halting the burner in the case of over pressure on the fuel supply line
- Digital Burner management system for air/fuel setting; with output PID modulation control as accessory
- AZL Display Interface, for combustion system commissioning and monitoring
- LMV26 Electronic cam for controlling the system safety
- UV flame sensor
- Star/delta starter or direct starter
- Main electrical supply terminal board
- Burner on/off switch
- Auxiliary voltage led signal
- Burner working led signal
- Contacts motor and thermal relay with release button
- Motor internal thermal protection
- Motor failure led signal
- Burner failure led signal and lighted release button
- Emergency button
- Coded connection plugs-sockets
- Burner opening hinge
- Lifting rings
- IP 54 electric protection level
- Gears pump for high pressure fuel supply
- Pump starting motor
- Oil safety valves
- Valve unit with double oil safety valve on the output circuit and double safety valve on the return circuit
- Oil/Gas selector
- Flame inspection window

Standard equipment:

- 1 flange gasket for gas train adaptor
- 1 adaptor for gas train
- 4 screws for fixing the flange
- 1 thermal screen
- 4 screws for fixing the burner flange to the boiler
- 2 flexible pipes for connection to the oil supply network
- 2 nipples for connection to the pump with gaskets
- 8 gas nozzles (only for RLS 310/E)
- Instruction handbook for installation, use and maintenance
- Spare parts catalogue.

Low NOx Modulating Dual Fuel Burners

RLS 310÷610/E MX SERIES

Available models

Burners

CODE	MODEL	HEAT OUTPUT			TOTAL ELECTRICAL POWER (kW)	CERTIFICATION
		(kW)	LIGHT OIL (kg/h)	NATURAL GAS (Nm ³ /h)		
20082946	RLS 310/E MX TC FS1 3/400/50	600/1200-3600	50/100-305	60/120-360	10,9 (oil) 9,1 (gas)	CE 0085CQ0196
20087644	RLS 310/E MX TC FS1 3/400/50	600/1200-3600	50/100-305	60/120-360	10,9 (oil) 9,1 (gas)	CE 0085CQ0196
20087646	RLS 410/E MX TC FS1 3/400/50	640/1500-4200	55/126-352	64/150-420	12,6 (oil) 10,8 (gas)	CE 0085CQ0196
20084376	RLS 410/E MX TC FS1 3/400/50	640/1500-4200	55/126-352	64/150-420	12,6 (oil) 10,8 (gas)	CE 0085CQ0196
20083562	RLS 510/E MX TC FS1 3/400/50	660/1800-5170	55/195-435	66/180-517	15,8 (oil) 14 (gas)	CE 0085CQ0196
20080180	RLS 610/E MX TC FS1 3/400/50	1000/2200-6155	86/185-516	100/220-615,5	18,8 (oil) 17 (gas)	CE 0085CQ0196

Net calorific value light oil: 11,8 kWh/kg; 10.200 kcal/kg - Viscosity at 20°C: 4-6 mm²/s (cSt).

Net calorific value G20 gas: 10 kWh/Nm³; 8.600 kcal/Nm³ - Density: 0,71 kg/Nm³.

The burners of RLS/E MX series are in according to 2016/426/EU - 2014/30/EU - 2014/35/EU - 2014/68/EU - 2006/42 CE Directive and EN 267 - 676 Norm.

RLS/EV - /EVi models with Variable Speed Drive System are available on demand.

For more information, please contact Riello Burners Commercial and Technical Department.

RLS 310÷610/E MX SERIES

Available models

Gas Trains

CODE	GAS TRAIN		ADAPTER CODE			
	MODEL	Ø	RLS 310	RLS 410	RLS 510	RLS 610
3970250*	MB 415/1 - RT 52	Rp 1" 1/2	3000826 + 20064220	●	●	●
3970257*	MB 420/1 - RT 52	Rp 2"	3000826 + 20042324	●	●	●
3970221*	MBC 1200/1 - RSM 60	Rp 2"	3000826 + 20042324			
3970222*	MBC 1900/1 - FSM 40	DN 65	3010221			
3970223*	MBC 3100/1 - FSM 40	DN 80	3010222			
3970224*	MBC 5000/1 - FSM 80	DN 100	3010222 - 3010370			
3970145*	CB 512/1 - RSM 30	Rp 1" 1/2	3000826 + 20064220		●	●
3970146*	CB 520/1 - RSM 30	Rp 2"	3000826 + 20042324			●
20044659*	CB 525/1 - RSM 30	Rp 2"	3000826 + 20042324			
3970147*	CB 5065/1 - FSM 30	DN 65	3010221			
3970148*	CB 5080/1 - FSM 30	DN 80	3010222			
3970149*	CB 50100/1 - FSM 30	DN 100	3010223 - 3010370			
20015871*	CB 50125/1 - FSM 30	DN 125	3010224			

Please see designation of Gas Train Series in the page before the Catalogue index.

* 230V/50Hz ~220V/60Hz electrical supply.

** 230V/50Hz electrical supply.

The valves seal control device is compulsory (conforming to EN 676) on gas trains to burners with a maximum output over 1200 kW.

The seal control function is managed by REC control box, by installation on gas train of a pressure switch (please see Gas train accessories paragraph).

To select the gas train please refer to the technical data leaflet and/or instruction manual.

● Not available.

Additional adapter not necessary, the gas train may be connected directly to the burner.

Low NOx Modulating Dual Fuel Burners

RLS 310÷610/E MX SERIES

Burner accessories

Nozzles

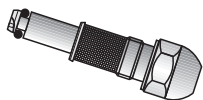

Return nozzles without needle are used on RLS/E MX burners. The nozzle must be ordered as accessory. The following table shows the features and codes on the basis of the maximum required fuel output.

BURNER	RATED DELIVERY (kg/h)	NOZZLE CODE ⁽¹⁾	NOZZLE CODE ⁽²⁾
▶ RLS 310-410/E MX	150	3009314	3045479
▶ RLS 310-410/E MX	175	3009316	3045481
▶ RLS 310-410/E MX	200	3009318	3045483
▶ RLS 310-410/E MX	225	3009320	3045485
▶ RLS 310-410-510/E MX	250	3009322	3045487
▶ RLS 310-410-510/E MX	275	3009324	3045489
▶ RLS 310-410-510-610/E MX	300	3009326	3045491
▶ RLS 310-410-510-610/E MX	325	3009328	3045493
▶ RLS 310-410-510-610/E MX	350	3009330	3045495
▶ RLS 310-410-510-610/E MX	375	3009332	3045497
▶ RLS 310-410-510-610/E MX	400	3009334	3045499
▶ RLS 310-410-510-610/E MX	425	3009336	3045500
▶ RLS 510-610/E MX	450	3009338	3045501
▶ RLS 610/E MX	475	3009340	-
▶ RLS 610/E MX	500	3009342	3045503
▶ RLS 610/E MX	525	3009344	-
▶ RLS 610/E MX	550	3009346	3045505
▶ RLS 610/E MX	575	3009348	-
▶ RLS 610/E MX	600	3009350	3045507

⁽¹⁾ Nozzle Bergonzo type B5 45° SA

⁽²⁾ Nozzle Fluidics type N2 45°

For more information please contact Riello Burners Commercial and Technical Department, our Application Engineers will be pleased to help you.

RLS 310÷610/E MX SERIES

Burner accessories

Accessories for modulating operation

POWER CONTROLLER



To obtain modulating operation, the RLS/E MX series of burners requires a regulator.
For remote setpoint use RWF 55.

BURNER	REGULATOR TYPE	REGULATOR CODE
► All models	RWF 50.2 - Basic version with - 3 position output	20085417
► All models	RWF 55.5 - Complete with RS-485 interface	20074441
► All models	RWF 55.6 - Complete with RS-485/ PROFIBUS interface	20074442

PROBE



The relative temperature or pressure probes fitted to the regulator, must be chosen on the basis of the application.

BURNER	PROBE TYPE	RANGE (°C) (bar)	PROBE CODE
► All models	Temperature PT 100	-100 ÷ 500°C	3010110
► All models	Pressure 4 ÷ 20 mA	0 ÷ 2,5 bar	3010213
► All models	Pressure 4 ÷ 20 mA	0 ÷ 16 bar	3010214

Continuous ventilation kit



If the burner requires continuous ventilation in the stages without flame, a special kit is available as given in the following table:

BURNER	KIT CODE
► RLS 310-410-510-610/E	20074542

Pc interface kit



To connect the control panel to a personal computer for the transmission of operation, fault signals and detailed service information, an interface adapter with PC software are available.

BURNER	KIT CODE
► RLS 310-410-510-610/E	(ACS410 + OCI410.30) - Service level 3010436

Low NOx Modulating Dual Fuel Burners

RLS 310÷610/E MX SERIES

Burner accessories

OCI412 interface kit



Interface kit between the REC 27.1 and a Modbus system, such as a building automation and control system (BACS).
The Modbus interface is based on the RS-485 standard.

BURNER	KIT CODE
► RLS 310-410-510-610/E	3010437

Sound proofing box

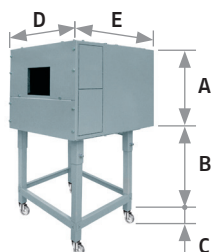

If noise emission needs reducing even further, sound-proofing boxes are available. When a lower "B" dimension is required, it is available the Box Support Kit code 20065135 which allows to reduce it at the fixed dimension of 55 mm. The sound-proofing boxes are not suitable for outdoor use.

BURNER	BOX TYPE	A (mm)	B (mm) min-max	C (mm)	D (mm)	E (mm)	[dB(A)] (*)	BOX CODE
► RLS 310-410/E	C7	1255	160 - 980	110	1140	1345	10	3010376
► RLS 510-610/E	C7 Plus	1255	160 - 980	110	1240	1345	10	20085111

(*) Average noise reduction according to EN 15036-1 standard

Spacer kit

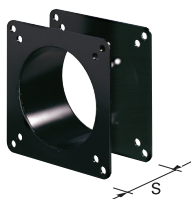

If burner head penetration into the combustion chamber needs reducing, varying thickness spacers are available, as given in the following table:

BURNER	Spacer thickness S (mm)	KIT CODE
► All models	180	20008903





Clean contacts kit

BURNER	KIT CODE
► All models	20096377

Gas train accessories

Adapters

In certain cases, an adapter must be fitted between the gas train and the burner, when the diameter of the gas train is different from the set diameter of the burner. Below are given the available adapters; please see on the Gas Train list the correct adapter codes to select.

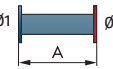
ADAPTER	DIMENSIONS				ADAPTER CODE
	Ø1 DN	Ø2 DN	A mm	B mm	
1" 1/2  2"	-	-	65	-	20064220
2"  2"	-	-	65	-	20042324
DN 80  2" 1/2  2"	-	-	300	-	3000826
	65	80	400	-	3010221
	80	80	400	-	3010222
	100	80	400	-	3010223
	125	80	320	-	3010224

PVP (pressure valve proving kit)*

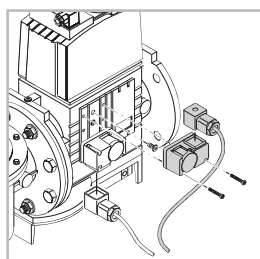

The seal control function is included on Burner Digital Management System, it is only necessary to add the PVP kit on the gas train.

GAS TRAIN	KIT CODE
► MB - CB - MBC type	3010344

Low NOx Modulating Dual Fuel Burners

RLS 310÷610/E MX SERIES

Gas train accessories

Stabiliser spring



To vary the pressure range of the gas train stabilisers, accessory springs are available. The following table shows these accessories with their application range. Please refer to the technical manual for the correct choice of spring.

GAS TRAIN	SPRING COLOUR	SPRING Pressure range mbar	SPRING CODE
MBC 1900/1 - 3100/1 MBC 5000/1	White	4 - 20	3010381
	Red	20 - 40	3010382
	Black	40 - 80	3010383
CB 512/1	Green	80 - 150	3010384
	Red	25 - 55	3010131
	Black	60 - 110	3010157
CB 520/1 - 525/1	Pink	90 - 150	3090486
	Red	25 - 55	3010132
	Black	60 - 110	3010158
CB 5065/1 - 5080/1	Pink	100 - 150	3090487
	Red	25 - 55	3010133
	Black	60 - 110	3010135
CB 50100/1	Pink	100 - 150	3090456
	Grey	140 - 200	3090992
	Red	25 - 55	3010134
CB 50125/1	Black	60 - 110	3010136
	Pink	100 - 150	3090489
	Grey	140 - 200	3092174
	Red	25 - 55	3010315
	Yellow	30 - 70	3010316
	Black	60 - 110	3010317
	Pink	100 - 150	3010318

RLS 300÷1200/E-EV MX SERIES

RLS/E-EV series burners are characterised by a modular monoblock structure that means all necessary components can be combined in a single unit thus making installation easier, faster and, above all, more flexible.

The series covers a firing range from 1250 to 11500 kW, and they have been designed for use in hot water boilers, overheated water boilers as well as steam boilers. Operation can be "two stage progressive" or alternatively "modulating" for both fuels, light oil and gas, with the installation of a PID logic regulator on the RLS 800/E series burners while RLS/EV and RLS 1000-1200/E series is fully "modulating". The burner can, therefore, supply with precision the demanded power, guaranteeing an high efficiency system level and the stability setting, obtaining fuel consumption and operating costs reduction.

The innovative combustion head, adjustment system ensures perfect movement during modulation as well as reducing noise and pollutants.





RLS 300/EV MX	600/1250	÷	3550 kW
RLS 400/EV MX	800/1800	÷	4300 kW
RLS 500/EV MX	1120/2500	÷	5050 kW
RLS 650/EV MX	1430/3000	÷	6550 kW
RLS 800/E-/EV MX	1750/3500	÷	8000 kW
RLS 1000/E-/EV MX	1200/3750	÷	10600 kW
RLS 1200/E-/EV MX	1500/5500	÷	11500 kW

Low NOx Modulating Dual Fuel Burners

RLS 300÷1200/E-EV MX SERIES

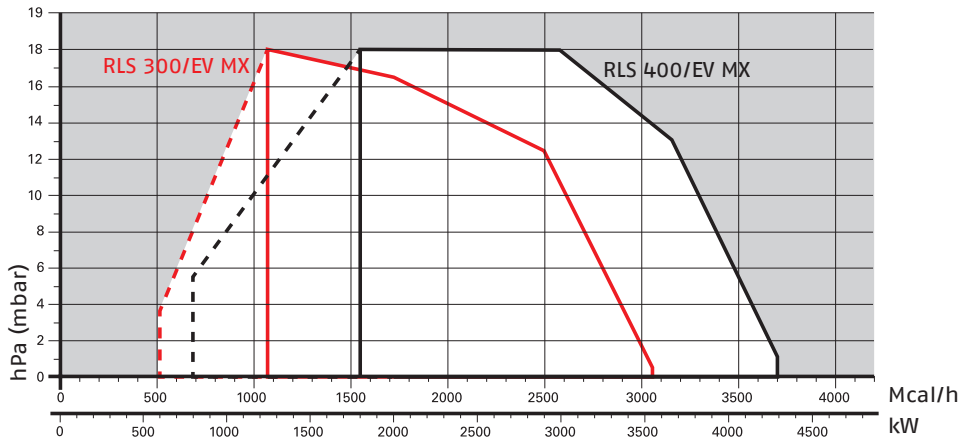
FIRING RATES



 Useful working field for choosing the burner

 Modulation range

Test conditions conforming to EN267- EN676
 Temperature: 20°C
 Pressure: 1013,5 mbar
 Altitude: 0 m a.s.l.

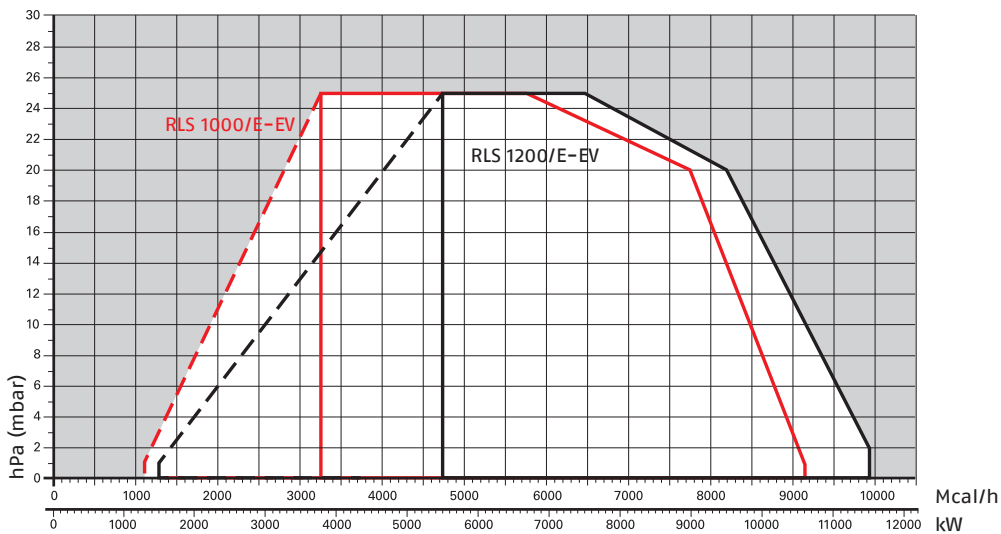
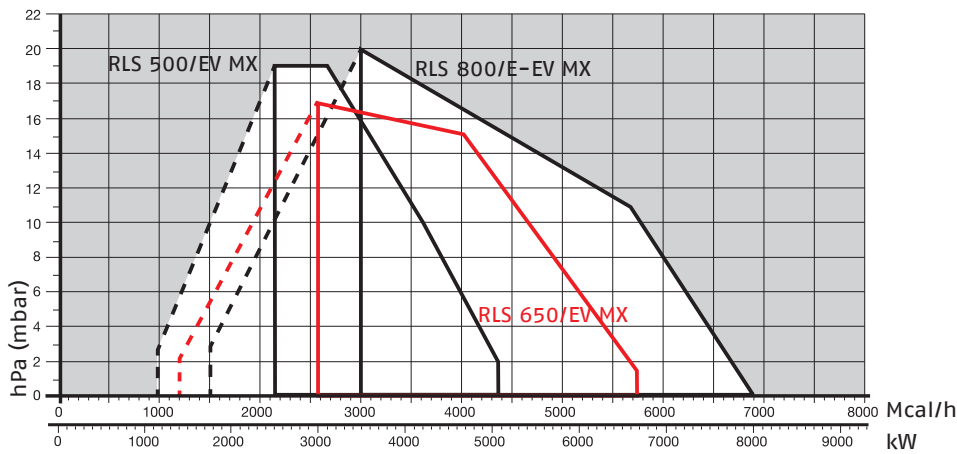

Overall dimensions (mm)

BURNER

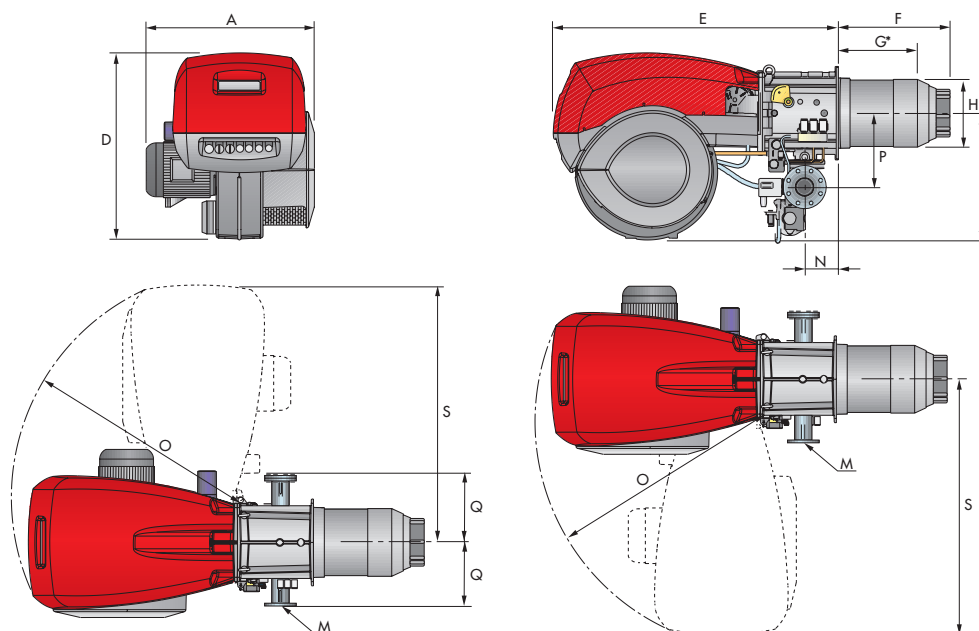

MODEL	A	D	E	F	G*	H	I	M	N	O	P	Q	S
▶ RLS 300/EV MX	720	890	1325	508	365	313	605	DN80	164	1055	342	320	1175
▶ RLS 400/EV MX	775	890	1325	508	365	313	605	DN80	164	1055	342	320	1175
▶ RLS 500/EV MX	815	890	1325	544	390	370	605	DN80	164	1055	342	320	1175
▶ RLS 650/EV MX	880	950	1325	549	397	410	630	DN80	164	1055	427	320	1190
▶ RLS 800/E-EV MX	940	937	1325	558	382	428	630	DN80	164	1055	427	320	1190

* Maximum depth of the boiler door including the depth of the burner flange insulating gasket.

BURNER - BOILER MOUNTING FLANGE

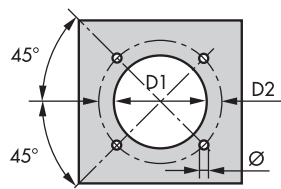

MODEL	D1	D2	Ø
▶ RLS 300/EV MX	350	452	M18
▶ RLS 400/EV MX	350	452	M18
▶ RLS 500/EV MX	390	452	M18
▶ RLS 650/EV MX	440	495	M18
▶ RLS 800/E-EV MX	440	495	M18

PACKAGING

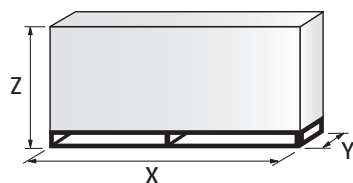

MODEL	X	Y	Z	kg
▶ RLS 300/EV MX	1960	970	1100	280
▶ RLS 400/EV MX	1960	970	1100	290
▶ RLS 500/EV MX	1960	970	1100	300
▶ RLS 650/EV MX	2190	1110	1450	320
▶ RLS 800/E-/EV MX	2190	1110	1450	320

Low NOx Modulating Dual Fuel Burners

RLS 300÷1200/E-EV MX SERIES

Overall dimensions (mm)

BURNER

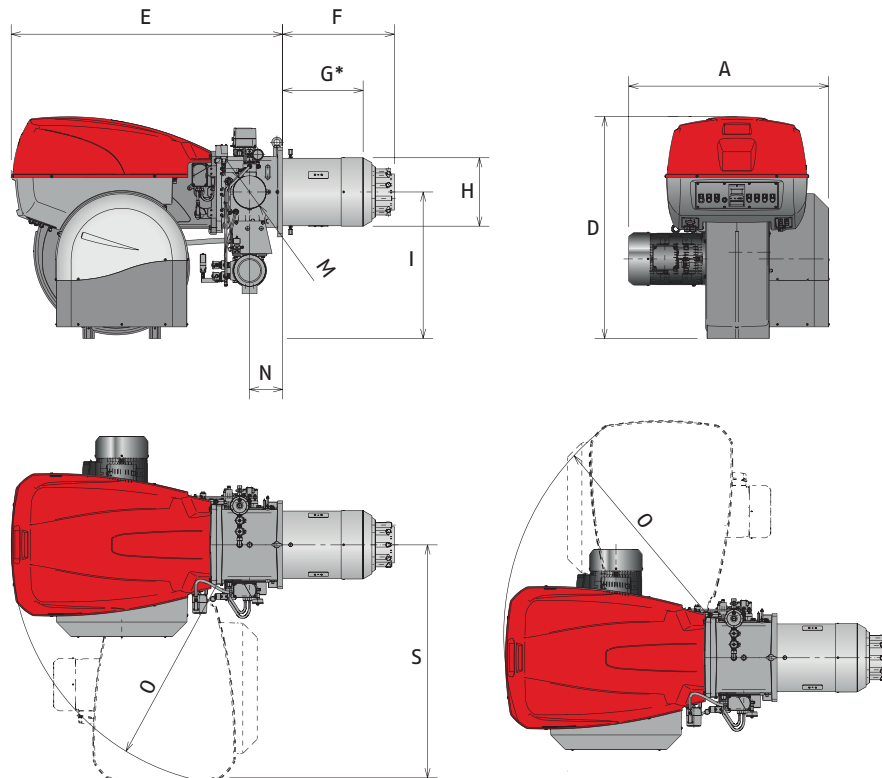

BURNER - BOILER MOUNTING FLANGE

MODEL	A	D	E	F	G*	H	I	M	N	O	S
► RLS 1000/E-/EV MX	1206	1338	1637	674	484	413	885	DN80	200	1350	1425
► RLS 1200/E-/EV MX	1250	1338	1637	658	465	456	885	DN80	200	1350	1425

* Maximum depth of the boiler door including the depth of the burner flange insulating gasket.

BURNER - BOILER MOUNTING FLANGE

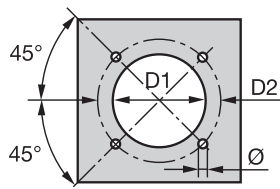

MODEL	D1	D2	Ø
► RLS 1000/E-/EV MX	460	608	M20
► RLS 1200/E-/EV MX	500	608	M20

PACKAGING

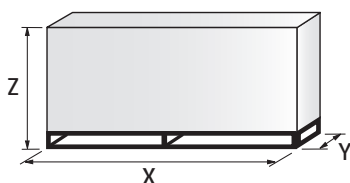

MODEL	X	Y	Z	kg
► RLS 1000/E-/EV MX	2400	1400	1595	550
► RLS 1200/E-/EV MX	2400	1400	1595	600

RLS 300÷1200/E-EV MX SERIES

Specification

DESIGNATION OF SERIES

Series: R

Fuel: S Natural Gas

L Light oil

LS Light oil/Natural Gas

N Heavy oil

Size:

Setting: /1 Single stage

/B Two stage

/M Modulating-Mechanical cam

/E Electronic cam

/P Proportioning air/gas valve

/EV Electronic cam predisposed for variable speed (with inverter)

/EVi Electronic cam with integrated inverter

Emission: ... or C11 Class 1 EN267 - EN676

MZ or C22 Class 2 EN267 - EN676

BLU or C33 Class 3 EN267 - EN676

MX or C23 Class 2 EN267 - Class 3 EN676

C13 Class 1 EN267 - Class 3 EN676

Head length: TC standard head

TL extended head

Flame control system: FS1 Standard/Intermittent (at least 1 stop every 24 h)

FS2 Continuous (1 stop every 72 h)

Electrical supply to the system:

1/230/50 1/230V/50Hz

3/230/50 3/230V/50Hz

3/400/50 3/400V/50Hz

3/230-400/50 3/230V/50Hz - 3N/400V/50Hz

3/220/60 3/220V/60Hz

3/380/60 3N/380V/60Hz

3/220-380/60 3/220/60Hz - 3N/380V/60Hz

Auxiliary voltage: 230/50 230V/50Hz

110/50-60 110V/50-60Hz

R LS 1200 /E MX TC FS1 3/400/50 230/50

BASIC DESIGNATION

EXTENDED DESIGNATION

Low NOx Modulating Dual Fuel Burners

RLS 300÷1200/E-EV MX SERIES

Specification

STATE OF SUPPLY

Monoblock forced draught gas burner with modulating operation, fully automatic, made up of:

- High performance fan with low sound emissions, reverse curve blades for RLS 300-400-1000-1200, forward curve blades for RLS 500-650-800
- Air suction circuit lined with sound-proofing material
- Air damper for air setting controlled by a high precision servomotor
- Air pressure switch
- Fan starting motor at 2800 rpm, three-phase 230/400 - 400/690 V with neutral, 50Hz
- Separate light oil pump
- Low emission combustion head, that can be set on the basis of required output, fitted with:
 - stainless steel end cone, resistant to corrosion and high temperatures
 - ignition electrodes
 - ignition by gas pilot with gas train for RLS 650-800-1000-1200 models
 - flame stability disk
- Maximum gas pressure switch, with pressure test point, for halting the burner in the case of over pressure on the fuel supply line
- Digital Burner management system for air/fuel setting; with output PID modulation control included on RLS/EV models, and RLS 1000-1200/E (available as accessory on RLS 800/E MX models)
- AZL Display Interface, for combustion system commissioning and monitoring, included in RLS/EV and RLS 1000-1200/E models (available as accessory for RLS 800/E BLU models)
- Electronic cam for controlling the system safety
- Infrared flame detector
- Star/delta starter for the fan motor (burners with motor electrical power $\geq 7,5$ kW - RLS/E versions)
- Main electrical supply terminal board
- Burner on/off switch
- Auxiliary voltage led signal
- Burner working led signal
- Contacts motor and thermal relay with release button
- Motor internal thermal protection
- Motor failure led signal
- Burner failure led signal and lighted release button
- Emergency button
- Coded connection plugs-sockets
- Burner opening hinge
- Lifting rings
- IP 54 electric protection level
- Gears pump for high pressure fuel supply
- Pump starting motor
- Oil safety valves
- Valve unit with double oil safety valve on the output circuit and double safety valve on the return circuit
- Oil/Gas selector
- Flame inspection window
- The gas train can only enter from the right side of the burner
- The RLS 1000-1200/E-/EV dual fuel burners are equipped with as spray lance for light oil, activated by compressed air.

Standard equipment:

- 1 flange gasket
- 4 screws for fixing the flange
- 1 thermal screen
- 4 screws for fixing the burner flange to the boiler
- 2 flexible pipes for connection to the oil supply network
- 2 nipples for connection to the pump with gaskets
- Seal control pressure switch (for installation on gas train)
- Instruction handbook for installation, use and maintenance
- Spare parts catalogue.

RLS 300÷1200/E-EV MX SERIES

Available models

Burners

CODE	MODEL				HEAT OUTPUT			TOTAL ELECTRICAL POWER (kW)	CERTIFICATION	NOTE
					(kW)	LIGHT OIL (kg/h)	NATURAL GAS (Nm ³ /h)			
3911132	RLS 800/E MX	TC FS1	3/400/50	230/50-60	1750/3500-8000	148/295-675	175/350-800	25,8 (oil) 24 (gas)	CE 0085CL0422	(1)(2)
20057529	RLS 1000/E MX	TC FS1	3/400/50	230/50-60	1200/3750-10600	110/320-793	130/380-940	27 (oil) 24 (gas)	CE 0085CN0119	(1)
20057530	RLS 1200/E MX	TC FS1	3/400/50	230/50-60	1500/5500-11500	126/464-970	150/550-1150	32 (oil) 27,2 (gas)	CE 0085CN0120	(1)
20022571	RLS 300/EV MX	TC FS1	3/400/50	230/50-60	600/1250-3550	50/105-300	60/125-355	7,5 (oil) 5,7 (gas)	CE 0085BR0471	(1)(2)
20022570	RLS 400/EV MX	TC FS1	3/400/50	230/50-60	800/1800-4300	67/152-363	80/180-430	11 (oil) 9,2 (gas)	CE 0085BR0472	(1)(2)
20099198	RLS 500/EV MX	TC FS1	3/400/50	230/50-60	1120/2500-5050	95/211-426	112/250-505	15,8 (oil) 14 (gas)	CE 0085CL0207	(1)(2)
20026959	RLS 650/EV MX	TC FS1	3/400/50	230/50-60	1430/3000-6550	121/253-552	143/300-655	23,5 (oil) 19,5 (gas)	CE 0085CL0422	(2)
20011318	RLS 800/EV MX	TC FS1	3/400/50	230/50-60	1750/3500-8000	148/295-675	175/350-800	25,8 (oil) 24 (gas)	CE 0085CL0422	(1)(2)
20051416	RLS 1000/EV MX	TC FS1	3/400/50	230/50-60	1200/3750-10600	110/320-793	130/380-940	27 (oil) 24 (gas)	CE 0085CN0119	(1)
20047475	RLS 1200/EV MX	TC FS1	3/400/50	230/50-60	1500/5500-11500	126/464-970	150/550-1150	32 (oil) 27,2 (gas)	CE 0085CN0120	(1)

Net calorific value light oil: 11,8 kWh/kg; 10.200 kcal/kg - Viscosity at 20°C: 4-6 mm²/s (cSt).

Net calorific value G20 gas: 10 kWh/Nm³; 8.600 kcal/Nm³ - Density: 0,71 kg/Nm³.

(1) according to 2016/426/EU - 2014/30/EU - 2014/35/EU - 2014/68/EU - 2006/42 CE Directive and EN 267 - 676 Norm.

(2) the burners are factory set for FS1 operation (1 stop every 24 h) but they can be switched to FS2 operation (continuous - 1 stop every 72 h) by changing the parameters through the AZL unit menu.

Low NOx Modulating Dual Fuel Burners

RLS 300÷1200/E-EV MX SERIES

Available models

Gas Trains

CODE*	GAS TRAIN MODEL	Ø	ADAPTER CODE						
			RLS 300	RLS 400	RLS 500	RLS 650	RLS 800	RLS 1000	RLS 1200
3970250	MB 415/1 - RT 52	Rp 1" 1/2	3000843 + 3000826 + 20064220	●	●	●	●	●	●
3970257	MB 420/1 - RT 52	Rp 2"	3000826 + 20042324	●	●	●	●	●	●
3970221	MBC 1200/1 - RSM 60	Rp 2"	3000826 + 20042324						
3970222	MBC 1900/1 - FSM 40	DN 65	3010221 - 3010369						
3970223	MBC 3100/1 - FSM 40	DN 80	3010222 (1)						
3970224	MBC 5000/1 - FSM 80	DN 100	3010223 - 3010370						
3970145	CB 512/1 - RSM 30	Rp 1" 1/2	3000843 + 3000826 + 20064220	●	●	●	●	●	●
3970146	CB 520/1 - RSM 30	Rp 2"	3000826 + 20042324	●	●	●	●	●	●
20044659	CB 525/1 - RSM 30	Rp 2"	3000826 + 20042324						
3970147	CB 5065/1 - FSM 30	DN 65	3010221 - 3010369						
3970148	CB 5080/1 - FSM 30	DN 80	3010222 (1)						
3970149	CB 50100/1 - FSM 30	DN 100	3010223 - 3010370						
20015871	CB 50125/1 - FSM 30	DN 125	3010224						

Please see designation of Gas Train Series in the page before the Catalogue index.

* gas train are 230V/50Hz - 220V/60Hz electrical supply.

The valve seal control device is compulsory (conforming to EN 676) on gas trains to burners with a maximum output over 1200 kW.

The seal control function is managed by LMV control box, by installation on gas train of pressure switch supplied, as standard equipment, with the burner.

To select the gas train please refer to the technical data leaflet and/or instruction manual.

● Not available.

□ Additional adapter not necessary, the gas train may be connected directly to the burner.

(1) To use if it is necessary to space out the gas train from the burner.

RLS 300÷1200/E-EV MX SERIES

Burner accessories

Nozzles

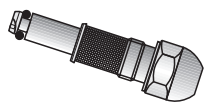

The nozzles must be ordered separately. The following table shows the features and codes on the basis of the maximum required fuel output.

BURNER	RATED DELIVERY (kg/h)	NOZZLE CODE
▶ RLS 300-400/EV MX	150	3009363
▶ RLS 300-400/EV MX	200	3009364
▶ RLS 300-400/EV MX	225	3009365
▶ RLS 300-400/EV MX	250	3009366
▶ RLS 300-400/EV MX	275	3009367
▶ RLS 300-400/EV MX	300	3009368
▶ RLS 400/EV MX	325	3009369
▶ RLS 400/EV MX	350	3009370
▶ RLS 400/EV MX	375	3009371
▶ RLS 400/EV MX	400	3009372
▶ RLS 400/EV MX	425	3009373
▶ RLS 500/EV MX	350	3045495
▶ RLS 500/EV MX	400	3045499
▶ RLS 500/EV MX	450	3045501
▶ RLS 500/EV MX	500	3045503
▶ RLS 650/EV MX	350	3045495
▶ RLS 650/EV MX	450	3045501
▶ RLS 650/EV MX	550	3045505
▶ RLS 650/EV MX	600	3045507
▶ RLS 800/E-EV MX	375	3009332
▶ RLS 800/E-EV MX	550	3009346
▶ RLS 800/E-EV MX	650	3009352
▶ RLS 800/E-EV MX	750	3009356
▶ RLS 1000/E-EV MX	350	20047954
▶ RLS 1000/E-EV MX	600	20047978
▶ RLS 1000/E-EV MX	750	20047985
▶ RLS 1000/E-EV MX	900	20047994
▶ RLS 1200/E-EV MX	700	20006479
▶ RLS 1200/E-EV MX	700	20006479
▶ RLS 1200/E-EV MX	900	20006482
▶ RLS 1200/E-EV MX	1100	20006484

For more information please contact Riello Burners Commercial and Technical Department, our Application Engineers will be pleased to help you.

Low NOx Modulating Dual Fuel Burners

RLS 300÷1200/E-EV MX SERIES

Burner accessories

Accessories for modulating operation



To obtain modulating operation, the RLS/E MX series of burners requires a regulator. In RLS/EV models PID regulator is integrated inside LMV 52 control box. For remote setpoint use RWF 55.

BURNER	REGULATOR TYPE	KIT CODE
▶ RLS 300-400-500-650-800/E MX	RWF 50.2	20101190
▶ RLS 300-400-500-650-800/E MX	RWF 55.5	20101191



The relative temperature or pressure probes fitted to the regulator, must be chosen on the basis of the application.

BURNER	PROBE TYPE	RANGE (°C) (bar)	PROBE CODE
▶ All models	Temperature PT 100	-100 ÷ 500°C	3010110
	Pressure 4 ÷ 20 mA	0 ÷ 2,5 bar	3010213
	Pressure 4 ÷ 20 mA	0 ÷ 16 bar	3010214
	Pressure 4 ÷ 20 mA	0 ÷ 25 bar	3090873

Variable Speed Drive (VSD) for RLS/EV series only



The motor speed variation for the RLS/EV burners series is obtained thanks to a frequency converter: variable speed drive (VSD), provided with a programming panel with start-up assistant. It always must be ordered with RLS/EV series.

BURNER	MAX POWER (kW)	KIT CODE
▶ RLS 300/EV	5.5	20163071
▶ RLS 400/EV	7.5	20163074
▶ RLS 500/EV	15	20163096
▶ RLS 650/EV	18.5	20163098
▶ RLS 800-1000/EV	22	20163099
▶ RLS 1200/EV	30	20163100

Oxygen Control kit (QGO₂)



The QGO₂ is an oxygen analyzer with relevant probe which controls and supervises the residual oxygen content in exhaust gases.

BURNER	KIT CODE
▶ All RLS/EV models	3010378
▶ All RLS/EV models	20045187 *

* Installation outside the burner cover

Burner accessories

PC Interface Software (AGS 450)

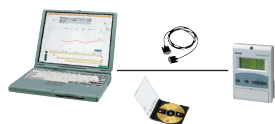

PC tool for convenient programming and burner settings, process visualization, data recording, selection of AZL language, software update AZL.

BURNER	KIT CODE
► All models	3010388

Kit efficiency with oxygen control kit (for RLS/EV only)



The kit includes two temperature sensors: one for air and one for exhaust gas detection. They must be wired to oxygen control kit interface to allow the LMV 52 efficiency calculation. The value is showed on AZL display.

BURNER	KIT CODE
► RLS 300-400-500-650-800/E-EV	3010377 (*)
► RLS 1000-1200/E-EV	20041584

(*) Probe type PT 1000 - range -80°C + 600°C

LPG kit



For burning LPG gas, a special kit is available to be fitted to the combustion head on the burner.

BURNER	KIT CODE
► RLS 300/EV MX	20039863 (*)
► RLS 400/EV MX	(1)
► RLS 500-650/EV MX	(1)
► RLS 800/E-EV MX	20007379
► RLS 1000-1200/E-EV MX	(1)

(*) CE approval on field is required.

(1) Not available

Display and Operating Unit (AZL)



This tool is needed for combustion system commissioning and monitoring. The AZL, Display and Operating Unit, is included in RLS 1000-1200/E and RLS/EV models.

BURNER	KIT CODE
► RLS 300-400-500-650-800/E MX	3010355
► All models *	3010469

* for Russian language only

Low NOx Modulating Dual Fuel Burners

RLS 300÷1200/E-EV MX SERIES

Burner accessories

Sound proofing box

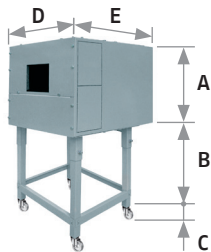

If noise emission needs reducing even further, sound-proofing boxes are available. When a lower "B" dimension is required, it is available the Box Support Kit code 20065135 which allows to reduce it at the fixed dimension of 55 mm. The sound-proofing boxes are not suitable for outdoor use.

BURNER	BOX TYPE	A (mm)	B (mm) min-max	C (mm)	D (mm)	E (mm)	[dB(A)] (*)	BOX CODE
▶ RLS 300-400-500/E-EV RLS 650-800/E-EV	C7	1255	160 - 980	110	1140	1345	10	3010376
▶ RLS 1000-1200/E-EV	C8	1425	285 - 1000	110	1500	1800	10	3010401

(*) Average noise reduction according to EN 15036-1 standard

Spacer kit

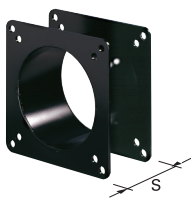

If burner head penetration into the combustion chamber needs reducing, varying thickness spacers are available, as given in the following table:

BURNER	SPACER THICKNESS S (mm)	KIT CODE
▶ RLS 300-400-500-650-800/E-EV	180	20008903

Gas train accessories

Adapters

In certain cases, an adapter must be fitted between the gas train and the burner, when the diameter of the gas train is different from the set diameter of the burner. Below are given the available adapters; please see on the Gas Train list the correct adapter codes to select.

ADAPTER	DIMENSIONS			ADAPTER CODE		
	Øi DN	ØO DN	A mm			
	65	80	400	-	-	3010221
	80	80	400	-	-	3010222
	100	80	400	-	-	3010223
	125	80	320	-	-	3010224
	65	80	10	-	-	3010369
	100	80	50	-	-	3010370
	-	-	35	-	-	3000843
	-	-	300	-	-	3000826
	-	-	65	-	-	20064220
	-	-	65	-	-	20042324

RLS 300÷1200/E-EV MX SERIES

Gas train accessories

Stabiliser spring



To vary the pressure range of the gas train stabilisers, accessory springs are available. The following table shows these accessories with their application range. Please refer to the technical manual for the correct choice of spring.

GAS TRAIN	SPRING COLOUR	SPRING PRESSURE RANGE mbar	SPRING CODE
▶ MBC 1900/1 - 3100/1 MBC 5000/1	White	4 - 20	3010381
	Red	20 - 40	3010382
	Black	40 - 80	3010383
	Green	80 - 150	3010384
▶ CB 512/1	Red	25 - 55	3010131
	Black	60 - 110	3010157
	Pink	90 - 150	3090486
▶ CB 520/1 - 525/1	Red	25 - 55	3010132
	Black	60 - 110	3010158
	Pink	100 - 150	3090487
▶ CB 5065/1 - 5080/1	Red	25 - 55	3010133
	Black	60 - 110	3010135
	Pink	100 - 150	3090456
	Grey	140 - 200	3090992
▶ CB 50100/1	Red	25 - 55	3010134
	Black	60 - 110	3010136
	Pink	100 - 150	3090489
	Grey	140 - 200	3092174
▶ CB 50125/1	Red	25 - 55	3010315
	Yellow	30 - 70	3010316
	Black	60 - 110	3010317
	Pink	100 - 150	3010318

RLS SERIES

The RLS series of burners covers a firing range from 163 to 1395 kW, and it has been designed for use in low or medium temperature hot water boilers, hot air or steam generators, diathermic oil boilers.

Operation is "two stage"; the burners are fitted with an electronic device LED PANEL, which supplies a diagnostic of burner status. Optimisation of sound emissions is guaranteed by the use of fans with reverse curve blades and sound deadening material incorporated in the air suction circuit. The elevated performance of the fans and combustion head guarantee flexibility of use and excellent working at all firing rates.

The exclusive design ensures reduced dimensions, simple use and maintenance. A wide range of accessories guarantees elevated working flexibility.



RLS 28	100/163 ÷	325 kW
RLS 38	116/232 ÷	442 kW
RLS 50	145/290 ÷	581 kW
RLS 70	232/465 ÷	814 kW
RLS 100	349/698 ÷	1163 kW
RLS 130	465/930 ÷	1395 kW

FIRING RATES

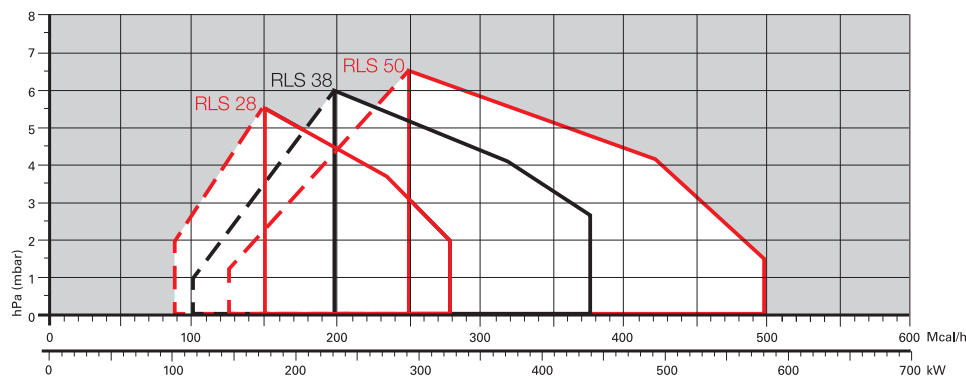

Useful working field for choosing the burner

Modulation range

Test conditions conforming to EN267- EN676
 Temperature: 20°C
 Pressure: 1013,5 mbar
 Altitude: 0 m a.s.l.

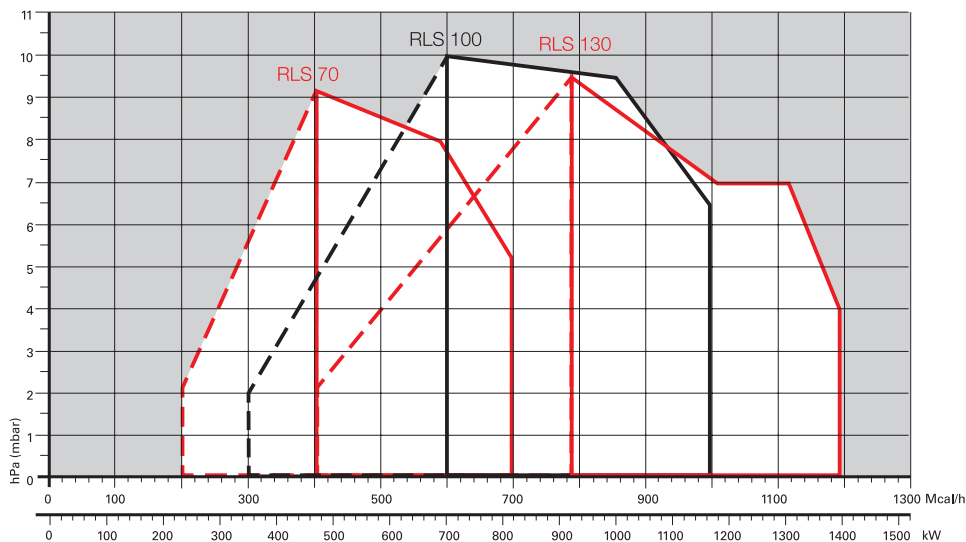

Two Stage Dual Fuel Burners

RLS SERIES

Overall dimensions (mm)

BURNER

RLS 28 - 38 - 50

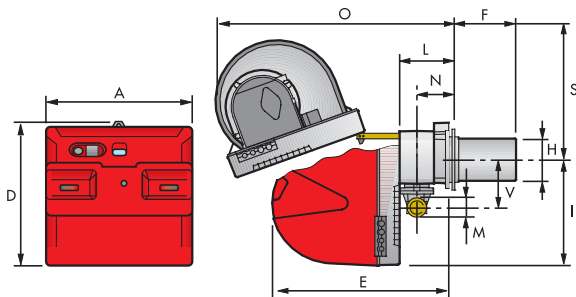

RLS 70 - 100 - 130

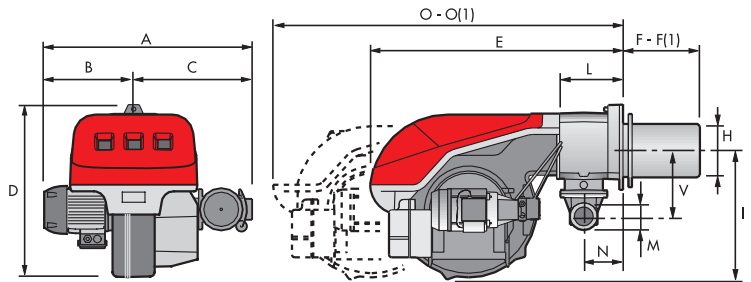

Model	A	B	C	D	E	F - F(1)	H	I	L	M	N	O - O(1)	S	V
▶ RLS 28	476	-	-	474	580	191 - 326	140	352	164	1 1/2"	108	810 - 810	367	168
▶ RLS 38	476	-	-	474	580	201 - 336	152	352	164	1 1/2"	108	810 - 810	367	168
▶ RLS 50	476	-	-	474	580	216 - 351	152	352	164	1 1/2"	108	810 - 810	367	168
▶ RLS 70	691	296	395	555	840	250 - 385	179	430	214	2"	134	1161 - 1361	-	221
▶ RLS 100	707	312	395	555	840	250 - 385	189	430	214	2"	134	1161 - 1361	-	221
▶ RLS 130	733	338	395	555	840	250 - 385	189	430	214	2"	134	1161 - 1361	-	221

(1) Length with extended combustion head

BURNER - BOILER MOUNTING FLANGE

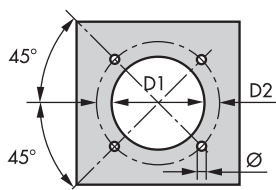

Model	D1	D2	Ø
▶ RLS 28	160	224	M8
▶ RLS 38	160	224	M8
▶ RLS 50	160	224	M8
▶ RLS 70	185	275-325	M12
▶ RLS 100	195	275-325	M12
▶ RLS 130	195	275-325	M12

PACKAGING

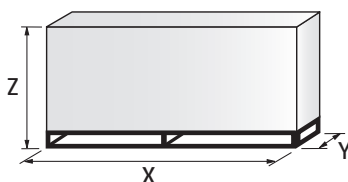

Model	X	Y	Z	kg
▶ RLS 28	1190	492	510	43
▶ RLS 38	1190	492	510	45
▶ RLS 50	1190	492	510	46
▶ RLS 70	1405	1000	660	70
▶ RLS 100	1405	1000	660	73
▶ RLS 130	1405	1000	660	76

Specification

DESIGNATION OF SERIES

Series: R									
Fuel: S Natural Gas									
L Light oil									
LS Light oil/Natural Gas									
N Heavy oil									
Size:									
Setting: /1 Single stage									
/B Two stage									
/M Modulating-Mechanical cam									
/E Electronic cam									
/P Proportioning air/gas valve									
/EV Electronic cam predisposed for variable speed (with inverter)									
/EVi Electronic cam with integrated inverter									
Emission: ... or C11 Class 1 EN267 - EN676									
MZ or C22 Class 2 EN267 - EN676									
BLU or C33 Class 3 EN267 - EN676									
MX or C23 Class 2 EN267 - Class 3 EN676									
C13 Class 1 EN267 - Class 3 EN676									
Head length: TC standard head									
TL extended head									
Flame control system: FS1 Standard/Intermittent (at least 1 stop every 24 h)									
FS2 Continuous (1 stop every 72 h)									
Electrical supply to the system:									
1/230/50 1/230V/50Hz									
3/230/50 3/230V/50Hz									
3/400/50 3/400V/50Hz									
3/230-400/50 3/230V/50Hz - 3N/400V/50Hz									
3/220/60 3/220V/60Hz									
3/380/60 3N/380V/60Hz									
3/220-380/60 3/220/60Hz - 3N/380V/60Hz									
Auxiliary voltage: 230/50 230V/50Hz									
110/50-60 110V/50-60Hz									

R	LS	28			TC	FS1	3/400/50	230/50
---	----	----	--	--	----	-----	----------	--------

BASIC DESIGNATION

EXTENDED DESIGNATION

Two Stage Dual Fuel Burners

RLS SERIES

Specification

STATE OF SUPPLY

Monobloc forced draught dual fuel burner, two stage operation, made up of:

- Air suction circuit lined with sound-proofing material
- Fan with reverse curve blades
- Fan starting motor
- Air damper for air setting controlled by a servomotor
- Minimum air pressure switch
- Combustion head, that can be set on the basis of required output
- Gears pump for high pressure fuel supply
- Pump starting motor
- Oil safety valves
- Two oil valves (1st and 2nd stage)
- Burner safety control box
- Electronic device to check all burners operational modes (Led Panel)
- UV photocell for flame detection
- Burner on/off switch
- Oil/Gas selector
- Manual 1st and 2nd stage switch
- Plugs for electrical connections (RLS 28-38-50)
- Flame inspection window
- Slide bars for easier installation and maintenance
- Protection filter against radio interference
- IP 44 electric protection level.

Standard equipment:

- 1 gas train flange
- 1 flange gasket
- 4 screws for fixing the flange
- 1 thermal screen
- 4 screws for fixing the burner flange to the boiler
- 2 flexible pipes for connection to the oil supply network
- 2 nipples for connection to the pump with gaskets
- Kit for transformation to LPG
- Fairleads for electrical connections (for RLS 28-38-50 model)
- Instruction handbook for installation, use and maintenance
- Spare parts catalogue.

Available models

Burners

CODE	MODEL		HEAT OUTPUT			TOTAL ELECTRICAL POWER (kW)	CERTIFICATION
			(kW)	LIGHT OIL (kg/h)	NATURAL GAS (Nm ³ /h)		
20147897	RLS 28 TC LP FS1 1/230/50	230/50	100/163-325	8,5/13,7-27,4	10/16-33	0,53	CE-0085CT0269
20159362	RLS 28 TC LP FS1 1/220/60	220/60	100/163-325	8,5/13,7-27,4	10/16-33	0,53	-
20148815	RLS 28 TL LP FS1 1/230/50	230/50	100/163-325	8,5/13,7-27,4	10/16-33	0,53	CE-0085CT0269
20147803	RLS 38 TC LP FS1 1/230/50	230/50	116/232-442	9,8/19,6-37,3	12/23-44	0,76	CE-0085CT0269
20148817	RLS 38 TL LP FS1 1/230/50	230/50	116/232-442	9,8/19,6-37,3	12/23-44	0,76	CE-0085CT0269
20147805	RLS 50 TC LP FS1 3/230-400/50	230/50	145/290-581	12,3/24,5-49	15/29-58	0,91	CE-0085CT0269
20159364	RLS 50 TC LP FS1 3/220-380/60	220/60	145/290-581	12,3/24,5-49	15/29-58	0,91	-
20148818	RLS 50 TL LP FS1 3/230-400/50	230/50	145/290-581	12,3/24,5-49	15/29-58	0,91	CE-0085CT0269

RLS SERIES

Available models

Burners

CODE	MODEL	HEAT OUTPUT			TOTAL ELECTRICAL POWER (kW)	CERTIFICATION
		(kW)	LIGHT OIL (kg/h)	NATURAL GAS (Nm ³ /h)		
20147798	RLS 70 TC LP FS1 3/230-400/50 230/50	232/465-814	19/39-69	23/47-81	2,0	CE-0085CT0269
20159363	RLS 70 TC LP FS1 3/208-230/380/60 230/50-60	232/465-814	19/39-69	23/47-81	2,0	-
20149563	RLS 70 TL LP FS1 3/230-400/50 230/50	232/465-814	19/39-69	23/47-81	2,0	CE-0085CT0269
20147799	RLS 100 TC LP FS1 3/230-400/50 230/50	349/698-1163	29,5/59-98	35/70-116	2,4	CE-0085CT0269
20159369	RLS 100 TC LP FS1 3/220/60 230/50	349/698-1163	29,5/59-98	35/70-116	2,5	-
20169257	RLS 100 TC LP FS1 3/208-230/380/60 230/50-60	349/698-1163	29,5/59-98	35/70-116	2,7	-
20149565	RLS 100 TL LP FS1 3/230-400/50 230/50	349/698-1163	29,5/59-98	35/70-116	2,4	CE-0085CT0269
20147800	RLS 130 TC LP FS1 3/230-400/50 230/50	465/930-1395	39/78-118	47/93-140	3,2	CE-0085CT0269
20169069	RLS 130 TC LP FS1 3/208-230/380/60 230/50-60	465/930-1395	39/78-118	47/93-140	3,2	-
20148028	RLS 130 TL LP FS1 3/230-400/50 230/50	465/930-1395	39/78-118	47/93-140	3,2	CE-0085CT0269

Net calorific value light oil: 11,8 kWh/kg; 10.200 kcal/kg - Viscosity at 20°C: 4-6 mm²/s (cSt).

Net calorific value G20 gas: 10 kWh/Nm³; 8.600 kcal/Nm³ - Density: 0,71 kg/Nm³.

The burners of RLS series are in according to 2014/30/EU - 2014/35/EU - 2016/426/EU - 2006/42 CE Directive and EN 267 - 676 Norm.

Due to the improvement applied on the technical specification of some products, some burner codes will change during year 2019. The table below summarizes the correspondence between the previous and the new code.

MODEL	NEW CODE	OLD CODE
RLS 28 TC LP FS1 1/230/50 230/50	20147897 (1)	3483201 (2)
RLS 28 TC LP FS1 1/220/60 220/60	20159362 (1)	20008836 (2)
RLS 28 TL LP FS1 1/230/50 230/50	20148815 (1)	20052632 (2)
RLS 38 TC LP FS1 1/230/50 230/50	20147803 (1)	3484101 (2)
RLS 38 TL LP FS1 1/230/50 230/50	20148817 (1)	20052633 (2)
RLS 50 TC LP FS1 3/230-400/50 230/50	20147805 (1)	3484601 (2)
RLS 50 TC LP FS1 3/220-380/60 220/60	20159364 (1)	20008911 (2)
RLS 50 TL LP FS1 3/230-400/50 230/50	20148818 (1)	20052634 (2)
RLS 70 TC LP FS1 3/230-400/50 230/50	20147798 (1)	3485001 (2)
RLS 70 TC LP FS1 3/208-230/380/60 230/50-60	20159363 (1)	3091489 (2)
RLS 70 TL LP FS1 3/230-400/50 230/50	20149563 (1)	20052635 (2)
RLS 100 TC LP FS1 3/230-400/50 230/50	20147799 (1)	3485201 (2)
RLS 100 TC LP FS1 3/220/60 230/50	20159369 (1)	3091842 (2)
RLS 100 TC LP FS1 3/208-230/380/60 230/50-60	20169257 (1)	3091589 (2)
RLS 100 TL LP FS1 3/230-400/50 230/50	20149565 (1)	20052636 (2)
RLS 130 TC LP FS1 3/230-400/50 230/50	20147800 (1)	3485401 (2)
RLS 130 TC LP FS1 3/208-230/380/60 230/50-60	20169069 (1)	20019826 (2)
RLS 130 TL LP FS1 3/230-400/50 230/50	20148028 (1)	20052638 (2)

(1) With RFGO control box

(2) With LFL control box

Net calorific value light oil: 11,8 kWh/kg; 10.200 kcal/kg - Viscosity at 20°C: 4-6 mm²/s (cSt).

Net calorific value G20 gas: 10 kWh/Nm³; 8.600 kcal/Nm³ - Density: 0,71 kg/Nm³.

The burners of RLS series are in according to 2014/30/EU - 2014/35/EU - 2016/426/EU - 2006/42 CE Directive and EN 267 - 676 Norm.

Two Stage Dual Fuel Burners

RLS SERIES

Available models

Gas Trains

CODE	GAS TRAIN			VPS CODE	ADAPTER CODE			
	MODEL	Ø	C.T.		RLS 28	RLS 38-50	RLS 70	RLS 100-130
3970084*	MB 405/2 - RSD 20	Rp 1/2"	-	3010123	20044756		●	●
3970537*	MB 407/2 - RSD 20	Rp 3/4"	-	3010123	3000824		●	●
3970556*	MB 407/2 - RT 20	Rp 3/4"	-	3010123			●	●
3970534*	MB 410/2 - RSD 20	Rp 3/4"	-	3010123			3000824+	●
3970557*	MB 410/2 - RT 20	Rp 3/4"	-	3010123			3000843	●
3970152*	MB 412/2 - RT 20	Rp 1" 1/2	-	3010123	□	□	3000843	
3970183*	MB 415/2 - RT 20	Rp 1" 1/2	-	3010123	□	□		
3970184*	MB 420/2 - RT 20	Rp 2"	-	3010123	3000822		□	□
3970185**	MB 420/2 CT RT 20	Rp 2"	◆	-			□	□
3970153*	CB 512/2 - RT 32	Rp 1" 1/2	-	3010123	□	□	3000843	
3970154*	CB 520/2 - RT 32	Rp 2"	-	3010123	3000822		□	□
3970155*	CB 5065/2 - FT 32	DN 65	-	3010123	●	3000825		
3970167**	CB 5065/2 CT FT 32	DN 65	◆	-	●			
3970156*	CB 5080/2 - FT 32	DN 80	-	3010123	●	●	3000826	
3970168**	CB 5080/2 CT FT 32	DN 80	◆	-	●	●		

Please see designation of Gas Train Series in the page before the Catalogue index.

* 230V/50Hz -220V/60Hz electrical supply.

** 230V/50Hz electrical supply.

The valve seal control device is compulsory (conforming to EN 676) on gas trains to burners with a maximum output over 1200 kW.

To select the gas train please refer to the technical data leaflet and/or instruction manual.

C.T. Gas valve leak detection control device:

- gas train not equipped with leak detection control device; this device can be ordered separately - see VPS column - and installed later.

◆ gas train equipped with leak detection control device.

VPS Valve leak detection control device. Supplied separately from the gas train (please see Gas train accessories paragraph for both 50 Hz and 60 Hz codes).

● Not available.

□ Additional adapter not necessary, the gas train may be connected directly to the burner.

Burner accessories

Degassing unit



To solve problem of air in the oil sucked, two versions of degassing unit are available.

BURNER	FILTER	FILTERING DEGREE (µm)	DEGASING UNIT CODE (*)
► RLS 28 - 38 - 50 RLS 70 - 100	With filter	50 - 75	3010055

(*) Max capability 80 kg/h (more filters are needed for higher flow).

Connection flange kit

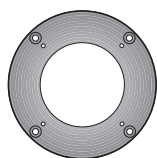

A kit is available for use where the burner opening on the boiler is of excessive diameter.

BURNER	KIT CODE
► RLS 28 - 38 - 50	3010138

Sound proofing box

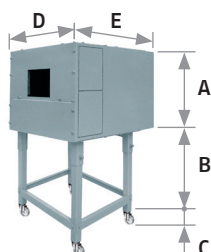

If noise emission needs reducing even further, sound-proofing boxes are available. When a lower "B" dimension is required, it is available the Box Support Kit code 20065135 which allows to reduce it at the fixed dimension of 55 mm. The sound-proofing boxes are not suitable for outdoor use.

BURNER	BOX TYPE	A (mm)	B (mm) min-max	C (mm)	D (mm)	E (mm)	[dB(A)] (*)	BOX CODE
► RLS 28 - 38 - 50	C1/3	650	372 - 980	110	690	770	10	3010403
► RLS 70 - 100 - 130	C4/5	850	160 - 980	110	980	930	10	3010404

(*) Average noise reduction according to EN 15036-1 standard

LPG kit

For burning LPG gas, a dedicated kit is available with RLS dual fuel burners as standard equipment, if necessary it is available also as accessory as given in the following table:

BURNER	KIT CODE FOR "STANDARD HEAD"	KIT CODE FOR "EXTENDED HEAD"
► RLS 28 - 38 - 50	3010304	3010304
► RLS 70 - 100 - 130	3010305	3010305

Gas max pressure switch kit

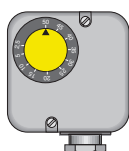

If necessary a Gas max pressure Switch kit is available.

BURNER	KIT CODE
► RLS 28 - 38 - 50 - 70 - 100 - 130	3010493

Two Stage Dual Fuel Burners

RLS SERIES

Burner accessories

Ground fault interrupter kit



A "Ground fault interrupter kit" is available as a safety device for electrical system fault.

BURNER	KIT CODE
▶ RLS 28-38-50	3010321
▶ RLS 70-100-130	20098337

Nozzles type 60° B



The nozzles must be ordered separately. The following table shows the features and codes on the basis of the maximum required fuel output.

NOTE: each burner needs N° 2 nozzles.

BURNER	RATED DELIVERY (kg/h) at 12 bar	GPH	NOZZLE CODE
▶ RLS 28	8,5	2,00	3042126
▶ RLS 28-38	10,6	2,50	3042140
▶ RLS 28-38-50	12,7	3,00	3042158
▶ RLS 28-38-50	14,8	3,50	3042162
▶ RLS 38-50	17	4,00	3042172
▶ RLS 38-50	19,1	4,50	3042182
▶ RLS 38-50-70	21,2	5,00	3042192
▶ RLS 50-70	23,3	5,50	3042202
▶ RLS 50-70	25,5	6,00	3042212
▶ RLS 50-70	27,6	6,50	3042222
▶ RLS 70-100	29,7	7,00	3042232
▶ RLS 70-100	31,8	7,50	3042242
▶ RLS 70-100	33,9	8,00	3042252
▶ RLS 70-100	36,1	8,50	3042262
▶ RLS 70-100-130	40,3	9,50	3042282
▶ RLS 70-100-130	42,4	10,00	3042292
▶ RLS 70-100-130	46,7	11,00	3042312
▶ RLS 100-130	50,9	12,00	3042322
▶ RLS 100-130	55,1	13,00	3042332
▶ RLS 100-130	59,4	14,00	3042352
▶ RLS 100-130	63,6	15,00	3042362
▶ RLS 100-130	67,9	16,00	3042382
▶ RLS 130	72,1	17,00	3042392

RLS SERIES

Burner accessories

Extended head kit

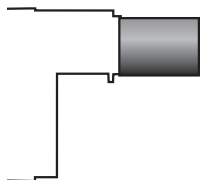

“Standard head” burners can be transformed into “extended head” versions, by using the special kit. The kits available for the various burners, giving the original and the extended lengths, are listed below.

BURNER	STANDARD HEAD LENGTH (mm)	EXTENDED HEAD LENGTH (mm)	KIT CODE
▶ RLS 28	191	326	20097840
▶ RLS 38	201	336	20097868
▶ RLS 50	216	351	20097869
▶ RLS 70	250	385	3010345
▶ RLS 100	250	385	3010346
▶ RLS 130	250	385	3010347

Continuous ventilation kit



If the burner requires continuous ventilation in the stages without flame, a special kit is available as given in the following table.

BURNER	KIT CODE
▶ RLS 190/M – 250/M MZ	3010094

Gas train accessories

Seal control kit



To test the valve seals on the gas train, a special “seal control kit” is available.

BURNER	GAS TRAIN	KIT CODE for 50 Hz operation	KIT CODE for 60 Hz operation
▶ RLS 28	MB 407/2 – MB 410/2	3010123	20168805
	MB 412/2 – MB 415/2 – MB 420/2		
	CB 512/2 – CB 520/2		
▶ RLS 38	MB 410/2 – MB 412/2	3010123	20168805
	MB 415/2 – MB 420/2		
	CB 512/2 – CB 520/2		
▶ RLS 50	MB 410/2 – MB 412/2	3010123	20168805
	MB 415/2 – MB 420/2		
	CB 512/2 – CB 520/2		
▶ RLS 70	MB 415/2 – MB 420/2	3010123	20168805
	CB 512/2 – CB 520/2 – CB 5065/2 – CB 5080/2		
	3010125		
▶ RLS 100	MB 415/2 – MB 420/2	3010123	20168805
	CB 512/2 – CB 520/2 – CB 5065/2 – CB 5080/2	3010125	20169320
▶ RLS 130	MB 415/2 – MB 420/2	3010123	20168805
	CB 512/2 – CB 520/2 – CB 5065/2 – CB 5080/2	3010125	20169320

Two Stage Dual Fuel Burners

RLS SERIES

Gas train accessories

Stabiliser spring









Accessory springs are available to vary the pressure range of the gas train stabilisers.

GAS TRAIN	SPRING COLOUR	SPRING PRESSURE RANGE mbar	SPRING CODE
▶ CB 512/2	Red	25 - 55	3010131
	Black	60 - 110	3010157
	Pink	90 - 150	3090486
▶ CB 520/2	Red	25 - 55	3010132
	Black	60 - 110	3010158
	Pink	100 - 150	3090487
▶ CB 5065/2 - 5080/2	Red	25 - 55	3010133
	Black	60 - 110	3010135
	Pink	100 - 150	3090456
	Grey	140 - 200	3090992

Adapters

In certain cases, an adapter must be fitted between the gas train and the burner, when the diameter of the gas train is different from the set diameter of the burner. Below are given the available adapters; please see on the Gas Train list the correct adapter codes to select.

ADAPTER	LENGTH mm	ADAPTER CODE
 2" 1 1/2"	70	3000822
 3/4" 1 1/2"	31	3000824
 DN 65 2" 2"	300	3000825
 2 1/2" 1 1/2"		
 DN 80 2" 2"	300	3000826
 1 1/2" 2"	35	3000843
 1/2" 1 1/2"	31	20044756

RLS/M MZ SERIES

The RLS/M MZ series of burners covers a firing range from 550 to 2460 kW, and they have been designed for use in hot or superheated water boilers, hot air or steam generators, diathermic oil boilers.

Operation is "two stage" at the oil side and "modulating" at the gas side with the installation of a PID logic regulator and respective probes.

RLS/M MZ series burners guarantees high efficiency levels in all the various applications, thus reducing fuel consumption and running costs.

Optimisation of sound emissions is guaranteed by the special design of air suction circuit and the use of sound proofing material.

The exclusive design ensures reduced dimensions, simple use and maintenance. A wide range of accessories guarantees elevated working flexibility.



RLS 190/M MZ	550/1100 ÷ 2150 kW
RLS 250/M MZ	550/1230 ÷ 2460 kW

FIRING RATES

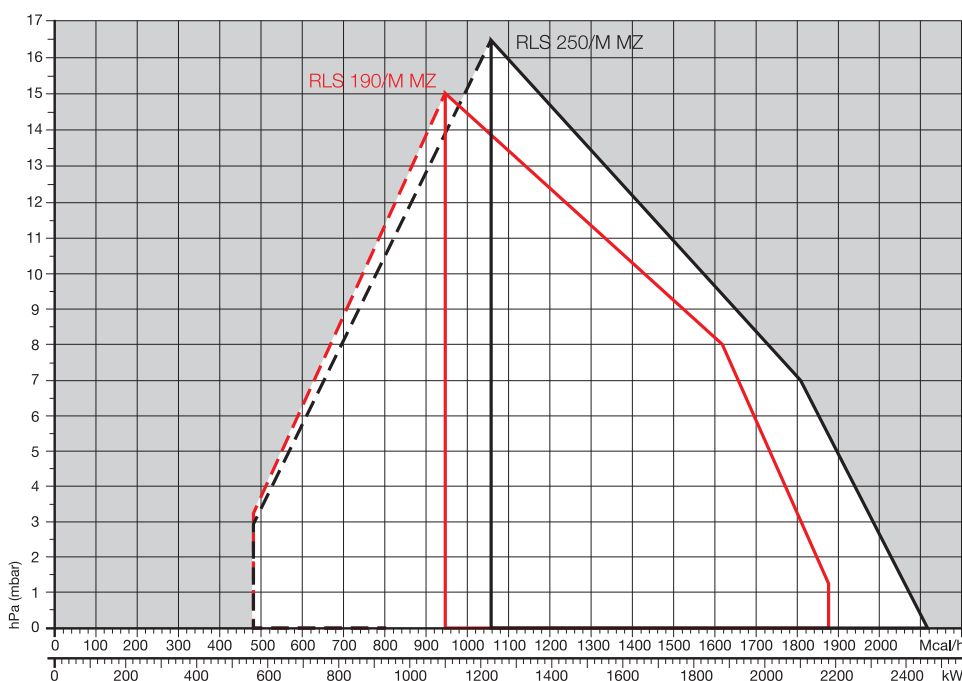

 Useful working field for choosing the burner

 Modulation range

Test conditions conforming to EN267- EN676
 Temperature: 20°C
 Pressure: 1013,5 mbar
 Altitude: 0 m a.s.l.

Modulating Dual Fuel Burners

RLS/M MZ SERIES

Overall dimensions (mm)

BURNER

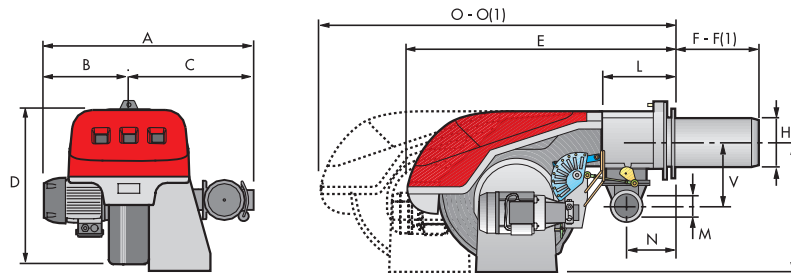

MODEL	A	B	C	D	E	F - F (1)	H	I	L	M	N	O - O (1)	V
► RLS 190/M MZ	843	366	477	555	863	412 - 542	222	430	237	Rp2	141	1442 - 1587	186
► RLS 250/M MZ	904	427	477	555	863	412 - 542	222	435	237	Rp2	141	1442 - 1587	186

(1) Length with extended combustion head.

BURNER - BOILER MOUNTING FLANGE

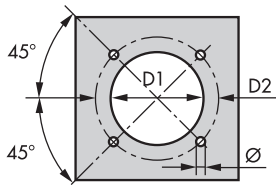

Model	D1	D2	∅
► RLS 190/M MZ	230	325 - 368	M16
► RLS 250/M MZ	230	325 - 368	M16

PACKAGING

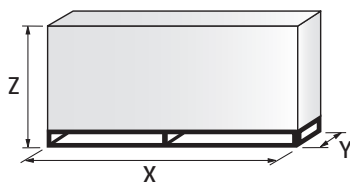

Model	X	Y	Z	kg
► RLS 190/M MZ	1400	975	645	95
► RLS 250/M MZ	1400	1000	765	100

RLS/M MZ SERIES

Specification

DESIGNATION OF SERIES

Series: R

Fuel: S Natural Gas
 L Light oil
 LS Light oil/Natural Gas
 N Heavy oil

Size:

Setting: /1 Single stage
 /B Two stage
 /M Modulating-Mechanical cam
 /E Electronic cam
 /P Proportioning air/gas valve
 /EV Electronic cam predisposed for variable speed (with inverter)
 /EVi Electronic cam with integrated inverter

Emission: ... or C11 Class 1 EN267 - EN676
 MZ or C22 Class 2 EN267 - EN676
 BLU or C33 Class 3 EN267 - EN676
 MX or C23 Class 2 EN267 - Class 3 EN676
 C13 Class 1 EN267 - Class 3 EN676

Head length: TC standard head
 TL extended head

Flame control system: FS1 Standard/Intermittent (at least 1 stop every 24 h)
 FS2 Continuous (1 stop every 72 h)

Electrical supply to the system:

1/230/50	1/230V/50Hz
3/230/50	3/230V/50Hz
3/400/50	3/400V/50Hz
3/230-400/50	3/230V/50Hz - 3N/400V/50Hz
3/220/60	3/220V/60Hz
3/380/60	3N/380V/60Hz
3/220-380/60	3/220/60Hz - 3N/380V/60Hz

Auxiliary voltage: 230/50	230V/50Hz
110/50-60	110V/50-60Hz

R	LS	190	/M	MZ	TC	FS1	3/400/50	230/50
---	----	-----	----	----	----	-----	----------	--------

BASIC DESIGNATION

EXTENDED DESIGNATION

Modulating Dual Fuel Burners

RLS/M MZ SERIES

Specification

STATE OF SUPPLY

Monoblock forced draught dual fuel burner with two stage operation at the oil side and two stage progressive or modulating operation at the gas side, with a specific kit, fully automatic, made up of:

- air suction circuit lined with sound-proofing material
- centrifugal fan with high performance and low sound emissions
- air damper for air flow setting and butterfly valve for regulating gas output controlled by a servomotor with variable cam
- starting motor at 2800 rpm, three-phase 400V with neutral, 50Hz
- low emission combustion head, that can be set on the basis of required output, fitted with:
 - stainless steel end cone, resistant to corrosion and high temperatures
 - ignition electrodes
 - gas distributor
 - flame stability disk
- maximum gas pressure switch to stop the burner in the case of excess pressure on the fuel supply line
- minimum air pressure switch stops the burner in case of insufficient air quantity at the combustion head
- gears pump for high pressure fuel supply
- pump starting motor
- oil safety valves
- two oil valves (1st and 2nd stage)
- burner safety control box
- UV photocell for flame detection
- burner on/off selection switch
- manual or automatic output increase/decrease selection switch
- Oil/Gas selector
- flame inspection window
- slide bars for easier installation and maintenance
- protection filter against radio interference
- IP 44 electric protection level.

Standard equipment:

- 1 gas train flange
- 1 flange gasket
- 4 screws for fixing the flange
- 1 thermal screen
- 4 screws for fixing the burner flange to the boiler
- 2 flexible pipes for connection to the oil supply network
- 2 nipples for connection to the pump with gaskets
- Instruction handbook for installation, use and maintenance
- Spare parts catalogue.

RLS/M MZ SERIES

Available models

Burners

CODE	MODEL	HEAT OUTPUT			TOTAL ELECTRICAL POWER (kW)	CERTIFICATION	NOTE
		(kW)	LIGHT OIL (kg/h)	NATURAL GAS (Nm ³ /h)			
20159361	RLS 190/M MZ TC FS1 3/400/50 230/50-60	550/1100-2150	46/93-181	55/110-215	6,0	CE 0085BP0439	(1)
20146760	RLS 190/M MZ TL FS1 3/400/50 230/50-60	550/1100-2150	46/93-181	55/110-215	6,0	CE 0085BP0439	(1)
20145372	RLS 250/M MZ TC FS1 3/400/50 230/50-60	550/1230-2460	46/104-208	55/123-246	7,5 (oil) 6,0 (gas)	CE 0085CM0153	(1)
20146578	RLS 250/M MZ TL FS1 3/400/50 230/50-60	550/1230-2460	46/104-208	55/123-246	7,5 (oil) 6,0 (gas)	CE 0085CM0153	(1)

Net calorific value light oil: 11,8 kWh/kg; 10.200 kcal/kg - Viscosity at 20°C: 4-6 mm²/s (cSt).

Net calorific value G20 gas: 10 kWh/Nm³; 8.600 kcal/Nm³ - Density: 0,71 kg/Nm³.

The burners of RLS/M MZ series are in according to 2016/426/EU - 2014/30/EU - 2014/35/EU - 2006/42 CE Directive and EN 267 - 676 Norm.

Due to the improvement applied on the technical specification of some products, some burner codes will change during year 2019. The table below summarizes the correspondence between the previous and the new code.

MODEL	NEW CODE	OLD CODE
RLS 190/M MZ TC FS1 3/400/50 230/50-60	20159361 (1)	3488110 (2)
RLS 190/M MZ TL FS1 3/400/50 230/50-60	20146760 (1)	20052642 (2)
RLS 250/M MZ TC FS1 3/400/50 230/50-60	20145372 (1)	3482810 (2)
RLS 250/M MZ TL FS1 3/400/50 230/50-60	20146578 (1)	20052649 (2)

Net calorific value light oil: 11,8 kWh/kg; 10.200 kcal/kg - Viscosity at 20°C: 4-6 mm²/s (cSt).

Net calorific value G20 gas: 10 kWh/Nm³; 8.600 kcal/Nm³ - Density: 0,71 kg/Nm³.

The burners of RLS/M series are in according to 2016/426/EU - 2014/30/EU - 2014/35/EU - 2006/42 CE Directive and EN 676 Norm.

(1) With RFGO control box.

(2) With LFL control box.

Modulating Dual Fuel Burners

RLS/M MZ SERIES

Available models

Gas Trains

CODE	GAS TRAIN			VPS CODE	ADAPTER CODE	
	MODEL	Ø	C.T.		RLS 190/M	RLS 250/M
3970180*	MB 415/1 - RT 30	Rp 1" 1/2	-	3010123		
3970198**	MB 415/1 CT RT 30	Rp 1" 1/2	◆	-		
3970250*	MB 415/1 - RT 52	Rp 1" 1/2	-	3010123		3000843
3970253**	MB 415/1 CT RT 52	Rp 1" 1/2	◆	-		
3970232*	MB 415/1 - RSM 30	Rp 1" 1/2	-	3010123		
3970181*	MB 420/1 - RT 30	Rp 2"	-	3010123	□	□
3970182**	MB 420/1 CT RT 30	Rp 2"	◆	-	□	□
3970257*	MB 420/1 - RT 52	Rp 2"	-	3010123	□	□
3970252**	MB 420/1 CT RT 52	Rp 2"	◆	-	□	□
3970233*	MB 420/1 - RSM 30	Rp 2"	-	3010123	□	□
3970234**	MB 420/1 CT RSM 30	Rp 2"	◆	-	□	□
3970221*	MBC 1200/1 - RSM 60	Rp 2"	-	3010123	□	□
3970225**	MBC 1200/1 CT RSM 60	Rp 2"	◆	-	□	□
3970222*	MBC 1900/1 - FSM 40	DN 65	-	3010123		3000825
3970226**	MBC 1900/1 CT FSM 40	DN 65	◆	-		
3970223*	MBC 3100/1 - FSM 40	DN 80	-	3010123		3000826
3970227**	MBC 3100/1 CT FSM 40	DN 80	◆	-		
3970224*	MBC 5000/1 - FSM 80	DN 100	-	3010123	●	3000826 + 3010370
3970228**	MBC 5000/1 CT FSM 80	DN 100	◆	-	●	
3970145*	CB 512/1 - RSM 30	Rp 1" 1/2	-	3010123		3000843
20045589**	CB 512/1 CT RSM 30	Rp 1" 1/2	◆	-		
3970146*	CB 520/1 - RSM 30	Rp 2"	-	3010123	□	□
3970160**	CB 520/1 CT RSM 30	Rp 2"	◆	-	□	□
20044659*	CB 525/1 - RSM 30	Rp 2"	-	3010123	□	□
20044660**	CB 525/1 CT RSM 30	Rp 2"	◆	-	□	□
3970147*	CB 5065/1 - FSM 30	DN 65	-	3010123		3000825
3970161**	CB 5065/1 CT FSM 30	DN 65	◆	-		
3970148*	CB 5080/1 - FSM 30	DN 80	-	3010123		3000826
3970162**	CB 5080/1 CT FSM 30	DN 80	◆	-		
3970149*	CB 50100/1 - FSM 30	DN 100	-	3010123		3000826 + 3010370
3970163**	CB 50100/1 CT FSM 30	DN 100	◆	-		
20015871*	CB 50125/1 - FSM 30	DN 125	-	3010123		3000826 + 3010224
3970196**	CB 50125/1 CT FSM 30	DN 125	◆	-		

Please see designation of Gas Train Series in the page before the Catalogue index.

* 230V/50Hz -220V/60Hz electrical supply.

** 230V/50Hz electrical supply.

The valve seal control device is compulsory (conforming to EN 676) on gas trains to burners with a maximum output over 1200 kW.

To select the gas train please refer to the technical data leaflet and/or instruction manual.

C.T. Gas valve leak detection control device:

- gas train not equipped with leak detection control device; this device can be ordered separately - see VPS column - and installed later.
- ◆ gas train equipped with leak detection control device.

VPS Valve leak detection control device. Supplied separately from the gas train (please see Gas train accessories paragraph for both 50 Hz and 60 Hz codes).

● Not available.

□ Additional adapter not necessary, the gas train may be connected directly to the burner.

Burner accessories

Nozzles type 60° B



The nozzles must be ordered separately. The following table shows the features and codes on the basis of the maximum required fuel output.

NOTE: each burner needs N° 2 nozzles.

BURNER	RATED DELIVERY kg/h (*)	GPH	NOZZLE
▶ RLS 190/M MZ	42,4	10,00	3042292
	46,7	11,00	3042312
	48,37	12,00	3042322
	52,79	13,00	3042332
	56,86	14,00	3042352
	60,92	15,00	3042362
	64,98	16,00	3042382
▶ RLS 190/M MZ RLS 250/M MZ	69,04	17,00	3042392
	73,10	18,00	3042412
	77,16	19,00	3042422
	81,22	20,00	3042442
	89,34	22,00	3042462
	97,47	24,00	3042472
	101,53	26,00	3042482
▶ RLS 250/M MZ	105,59	28,00	20018051
	122	30,00	3042502
	130,1	32,00	3042512
	142,1	35,00	3042522

(*) Nozzle rated delivery is referred to atomized pressure

LPG kit

For burning LPG gas, a special kit is available to be fitted to the combustion head on the burner, as given in the following table:

BURNER	KIT CODE FOR "STANDARD HEAD" (*)	KIT CODE FOR "EXTENDED HEAD" (*)
▶ RLS 190/M MZ	3091796	3091796
▶ RLS 250/M MZ	(1)	(1)

(*) Without CE certification
(1) Not available

Extended head kit

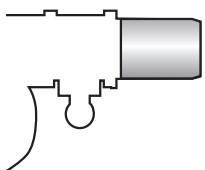

"Standard head" burners can be transformed into "extended head" versions, by using the special kit. The kits available for the various burners, giving the original and the extended lengths, are listed below.

BURNER	STANDARD HEAD LENGTH (mm)	EXTENDED HEAD LENGTH (mm)	KIT CODE
▶ RLS 190/M MZ	412	542	3010440 *
▶ RLS 250/M MZ	412	542	20029376

* Kit to be used on burners recognizable by a serial number that is over or equal to 02426XXXXXX, for burners with a serial number that is under or equal to 02416XXXXXX please use the Kit coded 3010366

Modulating Dual Fuel Burners

RLS/M MZ SERIES

Burner accessories

Spacer kit

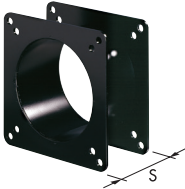

If burner head penetration into the combustion chamber needs reducing, varying thickness spacers are available, as given in the following table.

BURNER	SPACER THICKNESS S (mm)	KIT CODE
► RLS 190/M – 250/M MZ	102	3000722

Continuous ventilation kit



If the burner requires continuous ventilation in the stages without flame, a special kit is available as given in the following table.

BURNER	KIT CODE
► RLS 190/M – 250/M MZ	3010094

Accessories for modulating operation



To obtain modulating operation, the RLS/M MZ series of burners requires a regulator with three point outlet controls. The following table lists the accessories for modulating operation with their application range. For remote setpoint use RWF 55.

BURNER	TYPE	KIT CODE
► RLS 190/M – 250/M MZ	RWF 50.2	20099869
	RWF 55.5	20099905

PROBE



The relative temperature or pressure probes fitted to the regulator must be chosen on the basis of the application.

TYPE	RANGE (°C) (bar)	KIT CODE
Temperature PT 100	-100 ÷ 500°C	3010110
Pressure 4 ÷ 20 mA	0 ÷ 2,5 bar	3010213
Pressure 4 ÷ 20 mA	0 ÷ 16 bar	3010214
Pressure 4 ÷ 20 mA	0 ÷ 25 bar	3090873

ANALOG CONTROL SIGNAL CONVERTER



BURNER	TYPE (INPUT SIGNAL)	KIT CODE
► RLS 190/M – 250/M MZ	0/2 – 10 V (impedance 200 KΩ) 0/4 – 20 mA (impedance 250 Ω)	3010415

POTENTIOMETER KIT

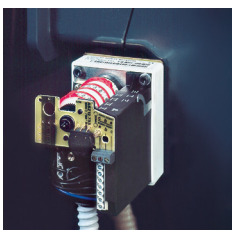

Depending on the servomotor fitted to the burner, a three-pole potentiometer (1000 Ω) can be installed to check the position of the servomotor. The KITS available for the various burners are listed below.

BURNER	KIT CODE
► RLS 190/M – 250/M MZ	3010416

RLS/M MZ SERIES

Burner accessories

Sound proofing box

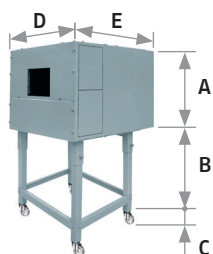

If noise emission needs reducing even further, sound-proofing boxes are available. When a lower "B" dimension is required, it is available the Box Support Kit code 20065135 which allows to reduce it at the fixed dimension of 55 mm. The sound-proofing boxes are not suitable for outdoor use.

BURNER	BOX TYPE	A (mm)	B (mm) min-max	C (mm)	D (mm)	E (mm)	[dB(A)] (*)	BOX CODE
► RLS 190-250/M MZ	C4/5	850	160 - 980	110	980	930	10	3010404

(*) Average noise reduction according to EN 15036-1 standard

Ground fault interrupter kit



A "Ground fault interrupter kit" is available as a safety device for electrical system fault.

BURNER	KIT CODE
► RLS 190-250/M MZ	20098337

Gas train accessories

Adapters

In certain cases, an adapter must be fitted between the gas train and the burner, when the diameter of the gas train is different from the set diameter of the burner. Below are given the available adapters; please see on the Gas Train list the correct adapter codes to select.

ADAPTER	LENGTH mm	ADAPTER CODE
 DN 65 2" 1/2 2"	300	3000825
 DN 65 2" 1/2 1" 1/2		
 DN 80 2" 1/2 2"	300	3000826
 1" 1/2 2"	35	3000843
 DN 100 DN 80	50	3010370
	320	3010224

Modulating Dual Fuel Burners

RLS/M MZ SERIES

Gas train accessories

Seal control kit



To test the valve seals on the gas train, a special “seal control kit” is available. The valve seal control device is compulsory (EN 676) on gas trains to burners with a maximum output over 1200 kW. The seal control is type VPS 504.

GAS TRAIN	KIT CODE for 50 Hz operation	KIT CODE for 60 Hz operation
▶ MB/1 type	3010123	20168805
▶ MBC/1 type	3010123	20168805
▶ CB/1 type	3010123	20168805

Stabiliser spring



Accessory springs are available to vary the pressure range of the gas train stabilisers. The following table shows these accessories with their application range. Please refer to the technical manual for the correct choice of spring.

GAS TRAIN	SPRING COLOUR	SPRING PRESSURE RANGE mbar	SPRING CODE
▶ MBC 1900/1 – 3100/1 MBC 5000/1	White	4 – 20	3010381
	Red	20 – 40	3010382
	Black	40 – 80	3010383
▶ CB 512/1	Green	80 – 150	3010384
	Red	25 – 55	3010131
	Black	60 – 110	3010157
▶ CB 520/1 – 525/1	Pink	90 – 150	3090486
	Red	25 – 55	3010132
	Black	60 – 110	3010158
▶ CB 5065/1 – 5080/1	Pink	100 – 150	3090487
	Red	25 – 55	3010133
	Black	60 – 110	3010135
▶ CB 50100/1	Pink	100 – 150	3090456
	Grey	140 – 200	3090992
	Red	25 – 55	3010134
▶ CB 50125/1	Black	60 – 110	3010136
	Pink	100 – 150	3090489
	Grey	140 – 200	3092174
▶ CB 50125/1	Red	25 – 55	3010315
	Yellow	30 – 70	3010316
	Black	60 – 110	3010317
	Pink	100 – 150	3010318

GI/EMME 1400÷4500 SERIES

The GI/EMME 1400-4500 series of burners covers a firing range from 820 to 4650 kW. They have been designed for high output users and they are suitable for matching with every kind of boilers, with normal or pressurized combustion chamber.

Operation can be "two stage progressive" or, alternatively, "modulating" with the installation of a PID logic regulator and respective probes. Two options of operation are available: only gas and only light oil, thus settable by a manual switch. Light oil circuit is fitted with his own electric motor: this permits pump stop during gas operation preventing danger of pumping seizure and avoiding oil circulation. A wide range of accessories and gas trains suitable to the burners guarantee an elevated working flexibility.

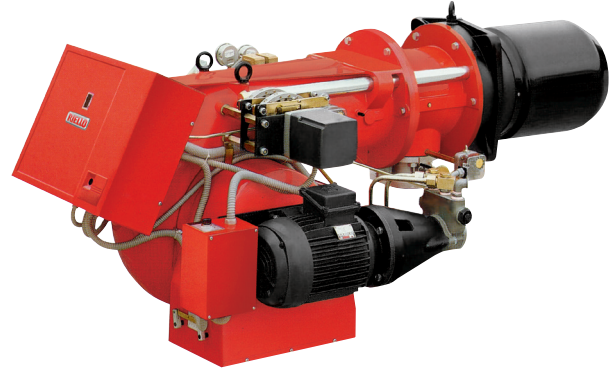

GI/EMME 1400	407/820 ÷ 1540 kW
GI/EMME 2000	581/1163 ÷ 2325 kW
GI/EMME 3000	872/1744 ÷ 3488 kW
GI/EMME 4500	1163/2350 ÷ 4650 kW

FIRING RATES

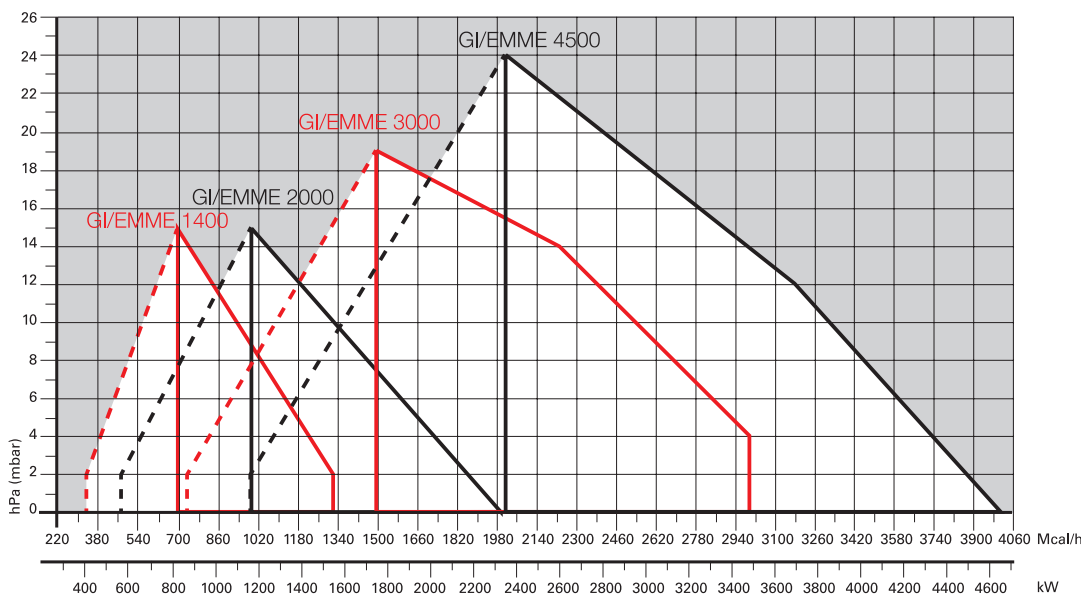

Useful working field for choosing the burner



Modulation range

Test conditions conforming to EN267- EN676
 Temperature: 20°C
 Pressure: 1013,5 mbar
 Altitude: 0 m a.s.l.

Modulating Dual Fuel Burners

GI/EMME 1400÷4500 SERIES

Overall dimensions (mm)

BURNER

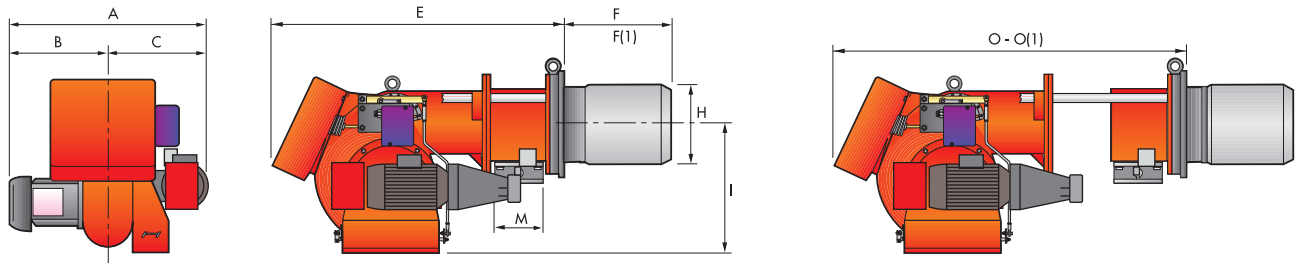

MODEL	A	B	C	E	F - F(1)	H	I	M	O - O(1)
▶ GI/EMME 1400	858	376	482	1090	385	250	467	2"	1407 - 1585
▶ GI/EMME 2000	878	396	482	1090	385	260	467	DN 80	1407 - 1585
▶ GI/EMME 3000	985	447	538	1320	476	336	525	DN 80	1796 - 2000
▶ GI/EMME 4500	1046	508	538	1320	476	336	525	DN 80	1796 - 1926

(1) Length with extended combustion head

BURNER - BOILER MOUNTING FLANGE

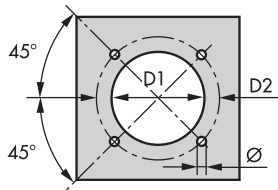

MODEL	D1	D2	Ø
▶ GI/EMME 1400	255	368	M16
▶ GI/EMME 2000	265	368	M16
▶ GI/EMME 3000	340	438	M20
▶ GI/EMME 4500	340	438	M20

PACKAGING

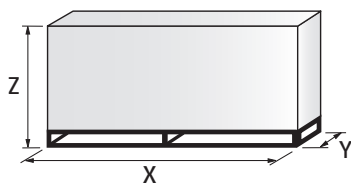

MODEL	X	Y	Z	kg
▶ GI/EMME 1400	1740	990	950	190
▶ GI/EMME 2000	1740	990	950	200
▶ GI/EMME 3000	2040	1180	1125	280
▶ GI/EMME 4500	2040	1180	1125	500

Specification

DESIGNATION OF SERIES

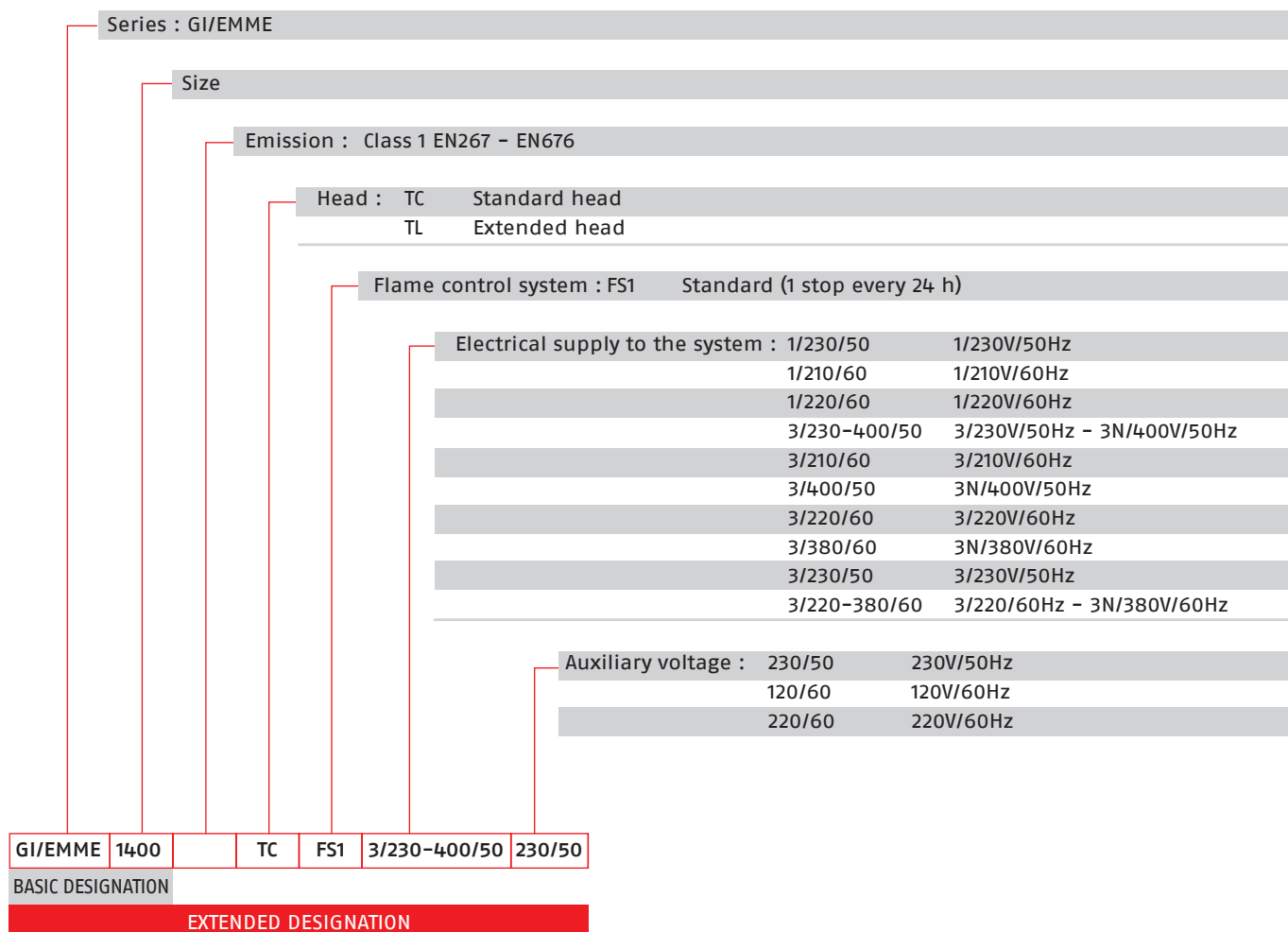

Modulating Dual Fuel Burners

GI/EMME 1400÷4500 SERIES

Specification

STATE OF SUPPLY

Monoblock forced draught dual fuel burner, two stage progressive or modulating operation with a kit, made up of:

- Air suction circuit
- Fan with forward curved blades
- Air damper for setting and butterfly valve for regulating fuel output controlled by a servomotor
- Combustion head, that can be set on the basis of required output
- Maximum gas pressure switch
- Minimum air pressure switch
- Fan electrical motor
- Pump electrical motor
- Gears pump for high pressure fuel supply, fitted with:
 - filter
 - pressure regulator
 - connections for installing a pressure gauge and a a vacuumeter
 - internal by-pass for single pipe installation
- Valve unit with a double oil safety valve on the output circuit and safety valve on the return circuit
- UV photocell for flame detection
- Flame inspection window
- Slide bars for easier installation and maintenance
- Protection filter against radio interference
- IP X0D (IP 40) protection level.

Standard equipment:

- 1 flange (for GI/EMME 1400)
- 1 gas train flange
- 8 screws for fixing the burner flange to the boiler (for GI/EMME 1400)
- 12 screws for fixing the burner flange to the boiler
- 1 insulating screen
- 2 flexible hoses for connection to the oil supply circuit
- 2 nipples for connection to the pump
- 4 wiring looms fittings for electrical connections
- 2 pin extensions
- 8 washers (for GI/EMME 1400)
- 12 washers
- Instruction handbook for installation, use and maintenance
- Spare parts catalogue.

Modulating Dual Fuel Burners

GI/EMME 1400÷4500 SERIES

RIELLO

Available models

Burners

CODE	MODEL	HEAT OUTPUT			MOTORS ELECTRICAL POWER (kW)	CERTIFICATION	NOTE
		(kW)	LIGHT OIL (kg/h)	NATURAL GAS (Nm ³ /h)			
20163249	GI/EMME 1400 TC FS1 3/230-400/50 230/50	407/820-1540	34/69-130	41/82-154	5,0	(1)	(7)
3487683	GI/EMME 2000 TC FS1 3/220-380/60 220/60	590/1163-2370	50/98-200	59/116-237	6,4	-	
20163312	GI/EMME 2000 TC FS1 3/230-400/50 230/50	581/1163-2325	49/98-196	58/116-233	6,4	(2)	(7)
3488783	GI/EMME 3000 TC FS1 3/380/60 220/60	890/1744-3560	75/147-300	89/174-356	10,7 - 12,5	-	(5)
20160903	GI/EMME 3000 TC FS1 3/400/50 230/50	872/1744-3488	74/147-294	87/174-349	10,7 - 12,5	(3)	(5)(7)
20162388	GI/EMME 3000 TC FS1 3/400/50 230/50	872/1744-3488	74/147-294	87/174-349	10,7 - 12,5	(3)	(6)(7)
20160912	GI/EMME 4500 TC FS1 3/400/50 230/50	1163/2350-4650	98/198-392	116/235-465	10,7 - 12,5	(4)	(6)(7)

(1) CE 0085AQ0712.

(2) CE 0085AQ0712.

(3) CE 0085AQ0712.

(4) CE 0085AQ0712.

(5) For the 3/230/50 version use the 220 - 230 V conversion kit (see the burner accessories paragraph)

(6) Star delta starter.

(7) with RFGO control box

Net calorific value light oil: 11,8 kWh/kg; 10.200 kcal/kg - Viscosity at 20°C: 4-6 mm²/s (cSt).

Net calorific value G20 gas: 10 kWh/Nm³; 8.600 kcal/Nm³ - Density: 0,71 kg/Nm³.

The burners of GI/EMME series are in according to 2016/426/EU - 2014/30/EU - 2014/35/EU - 2006/42 CE Directive and EN 267-676 Norm.

Due to the improvement applied on the technical specification of some products, some burner codes will change during year 2019. The table below summarizes the correspondence between the previous and the new code.

MODEL	NEW CODE	OLD CODE
GI/EMME 1400 TC FS1 3/230-400/50 230/50	20163249 (7)	3486655
GI/EMME 2000 TC FS1 3/230-400/50 230/50	20163312 (7)	3487657
GI/EMME 3000 TC FS1 3/400/50 230/50	20162388 (7)	3488759
GI/EMME 3000 TC FS1 3/400/50 230/50	20160903 (7)	3488757
GI/EMME 4500 TC FS1 3/400/50 230/50	20160912 (7)	3489065

Modulating Dual Fuel Burners

GI/EMME 1400÷4500 SERIES

Available models

Gas Trains

CODE	GAS TRAIN			VPS CODE	ADAPTER CODE			
	MODEL	Ø	C.T.		G/M 1400	G/M 2000	G/M 3000	G/M 4500
3970256*	MB 412/1 – RT 52	Rp 1" ¼	-	3010123	3010126	●	●	●
3970144*	MB 412/1 – RT 20	Rp 1" ¼	-	3010123		●	●	●
3970197**	MB 412/1 CT RT 20	Rp 1" ¼	◆	-		●	●	●
3970231*	MB 412/1 – RSM 20	Rp 1" ¼	-	3010123		●	●	●
3970180*	MB 415/1 – RT 30	Rp 1" ½	-	3010123	3000843	20064220 + 3010128		●
3970198**	MB 415/1 CT RT 30	Rp 1" ½	◆	-				●
3970250*	MB 415/1 – RT 52	Rp 1" ½	-	3010123				●
3970253**	MB 415/1 CT RT 52	Rp 1" ½	◆	-				●
3970232*	MB 415/1 – RSM 30	Rp 1" ½	-	3010123	□	20042324 + 3010128		●
3970181*	MB 420/1 – RT 30	Rp 2"	-	3010123				●
3970182**	MB 420/1 CT RT 30	Rp 2"	◆	-				●
3970257*	MB 420/1 – RT 52	Rp 2"	-	3010123				●
3970252**	MB 420/1 CT RT 52	Rp 2"	◆	-	□	20042324 + 3010128		●
3970233*	MB 420/1 – RSM 30	Rp 2"	-	3010123				●
3970234**	MB 420/1 CT RSM 30	Rp 2"	◆	-				●
3970221*	MBC 1200/1 – RSM 60	Rp 2"	-	3010123		20042324 + 3010128		
3970225**	MBC 1200/1 CT RSM 60	Rp 2"	◆	-	□			
3970222*	MBC 1900/1 – FSM 40	DN 65	-	3010123		3000825		3000831
3970226**	MBC 1900/1 CT FSM 40	DN 65	◆	-	□	3000826		3000832
3970223*	MBC 3100/1 – FSM 40	DN 80	-	3010123				
3970227**	MBC 3100/1 CT FSM 40	DN 80	◆	-	●	3010127		
3970224*	MBC 5000/1 – FSM 80	DN 100	-	3010123				
3970228**	MBC 5000/1 CT FSM 80	DN 100	◆	-	●	●		
3970145*	CB 512/1 – RSM 30	Rp 1" ½	-	3010123	3000843	20064220 + 3010128		●
20045589**	CB 512/1 CT RSM 30	Rp 1" ½	◆	-				●
3970146*	CB 520/1 – RSM 30	Rp 2"	-	3010123	□	20042324 + 3010128		
3970160**	CB 520/1 CT RSM 30	Rp 2"	◆	-				
20044659*	CB 525/1 – RSM 30	Rp 2"	-	3010123				
20044660**	CB 525/1 CT RSM 30	Rp 2"	◆	-				
3970147*	CB 5065/1 – FSM 30	DN 65	-	3010123	3000825	3000831		
3970161**	CB 5065/1 CT FSM 30	DN 65	◆	-				
3970148*	CB 5080/1 – FSM 30	DN 80	-	3010123	3000826	3000832		
3970162**	CB 5080/1 CT FSM 30	DN 80	◆	-				
3970149*	CB 50100/1 – FSM 30	DN 100	-	3010123	3010370 + 3000826	3010127		
3970163**	CB 50100/1 CT FSM 30	DN 100	◆	-				
20015871*	CB 50125/1 – FSM 30	DN 125	-	3010123	3010224 + 3000826	3090940		
3970196**	CB 50125/1 CT FSM 30	DN 125	◆	-				

Please see designation of Gas Train Series in the page before the Catalogue index.

* 230V/50Hz –220V/60Hz electrical supply.

** 230V/50Hz electrical supply.

The valve seal control device is compulsory (conforming to EN 676) on gas trains to burners with a maximum output over 1200 kW.

To select the gas train please refer to the technical data leaflet and/or instruction manual.

C.T. Gas valve leak detection control device:

- gas train not equipped with leak detection control device; this device can be ordered separately – see VPS column – and installed later.

◆ gas train equipped with leak detection control device.

VPS Valve leak detection control device. Supplied separately from the gas train (please see Gas train accessories paragraph for both 50 Hz and 60 Hz codes).

● Not available.

□ Additional adapter not necessary, the gas train may be connected directly to the burner.

Burner accessories

Nozzles type B5-SA 45°

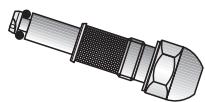

The nozzles must be ordered separately. The following table shows the features and codes on the basis of the maximum required fuel output.

NOTE: each burner needs N° 1 nozzle.

BURNER	RATED DELIVERY (kg/h)	NOZZLE CODE (1)	NOZZLE CODE (2)
▶ GI/EMME 1400	70	3009303	3045471
▶ GI/EMME 1400	80	3009305	3045472
▶ GI/EMME 1400	90	3009307	3045473
▶ GI/EMME 1400 - 2000	100	3009310	3045475
▶ GI/EMME 1400 - 2000	125	3009312	3045477
▶ GI/EMME 2000 - 3000	150	3009314	3045479
▶ GI/EMME 2000 - 3000	175	3009316	3045481
▶ GI/EMME 2000 - 3000 - 4500	200	3009318	3045483
▶ GI/EMME 3000 - 4500	225	3009320	3045485
▶ GI/EMME 3000 - 4500	250	3009322	3045487
▶ GI/EMME 3000 - 4500	275	3009324	3045489
▶ GI/EMME 3000 - 4500	300	3009326	3045491
▶ GI/EMME 4500	325	3009328	3045493
▶ GI/EMME 4500	350	3009330	3045495
▶ GI/EMME 4500	375	3009332	3045497
▶ GI/EMME 4500	400	3009334	3045499

(1) Nozzles Bergonzo B5 45° - without "SA" needle code.

(2) Nozzles Fluidics N2 45° - without needle code.

Spacer kit

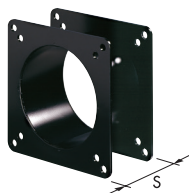

If burner head penetration into the combustion chamber needs reducing, varying thickness spacers are available, as given in the following list.

BURNER	SPACER THICKNESS S (mm)	KIT CODE
▶ GI/EMME 1400 - 2000	102	3000722
▶ GI/EMME 3000 - 4500	130	3000751

Sound proofing box

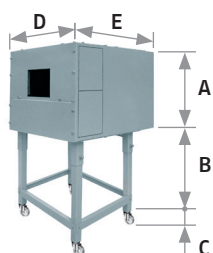

If noise emission needs reducing even further, sound-proofing boxes are available. When a lower "B" dimension is required, it is available the Box Support Kit code 20065135 which allows to reduce it at the fixed dimension of 55 mm. The sound-proofing boxes are not suitable for outdoor use.

BURNER	BOX TYPE (mm)	A (mm)	B (mm) min-max	C (mm)	D (mm)	E (mm)	[dB(A)] (*)	BOX CODE
▶ GI/EMME 1400 - 2000	C7	1255	160 - 980	110	1140	1345	10	3010376
▶ GI/EMME 3000 - 4500								

(*) Average noise reduction according to EN 15036-1 standard

Modulating Dual Fuel Burners

GI/EMME 1400÷4500 SERIES

Burner accessories

Accessories for modulating operation



To obtain modulating operation, the GI/EMME series of burners requires a regulator. For remote setpoint use RWF 55.

BURNER	REGULATOR TYPE	REGULATOR CODE
▶ GI/EMME 1400 - 2000 - 3000 - 4500	RWF 50.2	20100018
	RWF 55.5	20101965

The relative temperature or pressure probes fitted to the regulator, must be chosen on the basis of the application.

BURNER	PROBE TYPE	RANGE (°C) (bar)	PROBE CODE
▶ GI/EMME 1400 - 2000 GI/EMME 3000 - 4500	Temperature PT 100	-100 ÷ 500°C	3010110
	Pressure 4 ÷ 20 mA	0 ÷ 2,5 bar	3010213
	Pressure 4 ÷ 20 mA	0 ÷ 16 bar	3010214
	Pressure 4 ÷ 20 mA	0 ÷ 25 bar	3090873

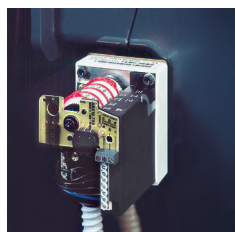

Depending on the servomotor fitted to the burner, a three-pole potentiometer (1000 Ω) can be installed to check the position of the servomotor.

BURNER	POTENTIOMETER KIT CODE
▶ GI/EMME 1400 - 2000 - 3000 - 4500	20096322

LPG kit

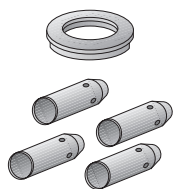

For burning LPG gas, a special kit is available to be fitted to the combustion head on the burner, as given in the following table.

BURNER	KIT CODE FOR 'STANDARD HEAD' (*)	KIT CODE FOR 'EXTENDED HEAD' (*)
▶ GI/EMME 1400 - 2000	3010063	3010063
▶ GI/EMME 3000	3090223	3090223
▶ GI/EMME 4500	3090937	3090937

(*) Without CE certification

Burner support

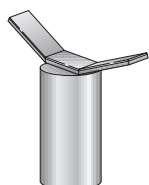

For easier maintenance, a mobile burner support has been designed, which means the burner can be dismantled without the need of forklift trucks.

BURNER	SUPPORT CODE
▶ GI/EMME 1400 - 2000 - 3000 - 4500	3000731

Burner accessories

220-230 V conversion kit







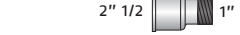
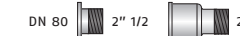

This kit is required to convert the 380-400 V models into the 220 or 230 V version.

BURNER	SUPPORT CODE
▶ GI/EMME 3000	20163347

Gas train accessories

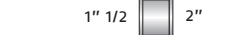
Adapters

In certain cases, an adapter must be fitted between the gas train and the burner, when the diameter of the gas train is different from the set diameter of the burner. Below are given the available adapters; please see on the Gas Train list the correct adapter codes to select.

ADAPTER	LENGTH mm	ADAPTER CODE
 DN 65 2" 1/2 2"	300	3000825
 DN 65 2" 1/2 1" 1/2		
 DN 80 2" 1/2 2"	300	3000826
 1" 1/2 2"	35	3000843
 1" 1/4 2"	35	3010126
 DN 100 DN 80	50	3010370
 1" 1/2 2"	65	20064220
 2" 2"	65	20042324
 DN 65 DN 80	320	3000831
 DN 80 DN 80	320	3000832
 DN 100 DN 80	320	3010127
 DN 80 DN 65 2" 1/2 2"	540	3010128

Modulating Dual Fuel Burners

GI/EMME 1400÷4500 SERIES

Gas train accessories

Stabiliser spring



To vary the pressure range of the gas train stabilisers, accessory springs are available. The following table shows these accessories with their application range. Please refer to the technical manual for the correct choice of spring.

GAS TRAIN	SPRING COLOUR	SPRING PRESSURE RANGE mbar	SPRING CODE
▶ MBC 1900/1 – 3100/1 MBC 5000/1	White	4 – 20	3010381
	Red	20 – 40	3010382
	Black	40 – 80	3010383
	Green	80 – 150	3010384
▶ CB 512/1	Red	25 – 55	3010131
	Black	60 – 110	3010157
	Pink	90 – 150	3090486
▶ CB 520/1 – 525/1	Red	25 – 55	3010132
	Black	60 – 110	3010158
	Pink	100 – 150	3090487
▶ CB 5065/1 – 5080/1	Red	25 – 55	3010133
	Black	60 – 110	3010135
	Pink	100 – 150	3090456
▶ CB 50100/1	Grey	140 – 200	3090992
	Red	25 – 55	3010134
	Black	60 – 110	3010136
	Pink	100 – 150	3090489
▶ CB 50125/1	Grey	140 – 200	3092174
	Red	25 – 55	3010315
	Yellow	30 – 70	3010316
	Black	60 – 110	3010317
	Pink	100 – 150	3010318

Seal control kit



To test the valve seals on the gas train, a special “seal control kit” is available. The valve seal control device is compulsory (EN 676) on gas trains to burners with a maximum output over 1200 kW. The seal control is type VPS 504.

GAS TRAIN	KIT CODE for 50 Hz operation	KIT CODE for 60 Hz operation
▶ MB/1 type	3010123	20168805
▶ MBC/1 type	3010123	20168805
▶ CB/1 type	3010123	20168805

RLS 1300÷2000/E-/EV C11 SERIES

The RLS/E and RLS/EV C11 dual fuel burners series are characterized by a modular monoblock structure that means all necessary components can be combined in a single unit thus making installation easier, faster and, above all, more flexible.

The burners cover a firing range from 7500 to 19500 kW and they have been designed for use in hot water boilers or industrial steam generators.

Operation can be modulating on the RLS/E series and modulating with variable speed drive operation on RLS/EV series.

The mechanisms of regulation allow to catch up a high modulation ratio on all firing rates range.

The burner can, therefore, supply with precision the demanded power, guaranteeing an high efficiency system level and the stability setting, obtaining fuel consumption and operating costs reduction.

The burner operation can be intermittent or continuous by menu setting.

The innovative combustion head, adjustment system ensures perfect movement during modulation.



RLS 1300/E-/EV C11	1100/7500 ÷ 13000 kW
RLS 1600/E-/EV C11	3065/9503 ÷ 15560 kW
RLS 2000/E-/EV C11	4000/12000 ÷ 19500 kW

Modulating Dual Fuel Burners

RLS 1300÷2000/E-/EV C11 SERIES

FIRING RATES

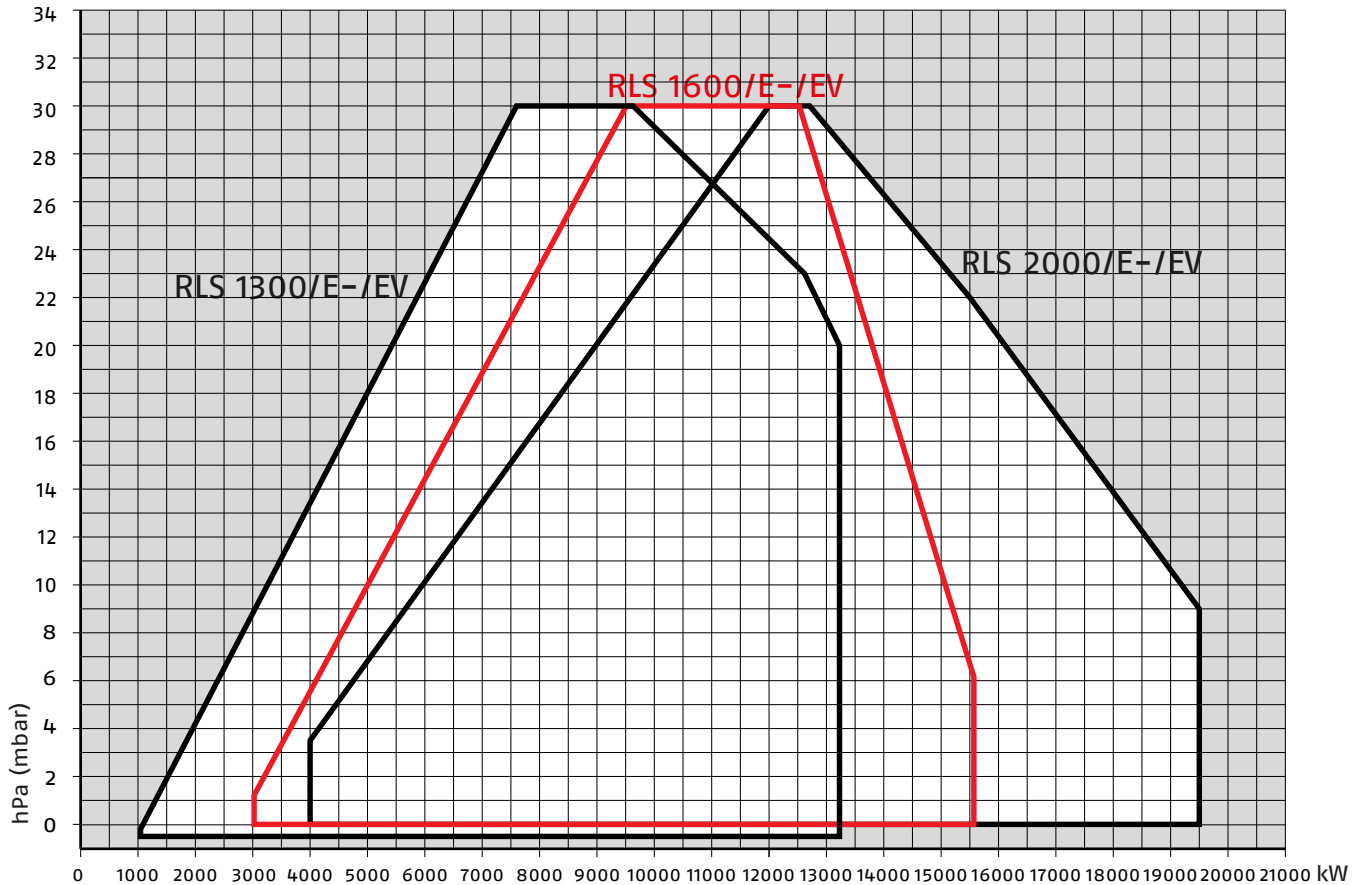

□ Useful working field for choosing the burner

┌──┐
└──┘ Modulation range

Test conditions conforming to EN267- EN676
Temperature: 20°C
Pressure: 1013,5 mbar
Altitude: 0 m a.s.l.

Modulating Dual Fuel Burners

RLS 1300÷2000/E-/EV C11 SERIES

RIELLO

Overall dimensions (mm)

BURNER

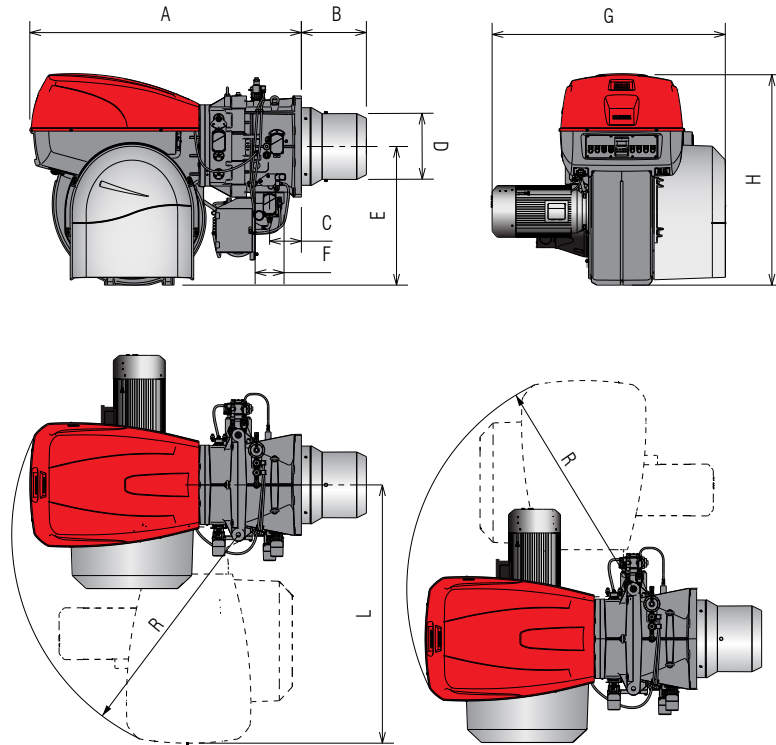

MODEL	A	B	C	D	E	F	G	H	I	L	R
► RLS 1300/E-/EV C11	1880	450	220	544	459	DN80	1620	1463	380	1787	1564

BURNER - BOILER MOUNTING FLANGE

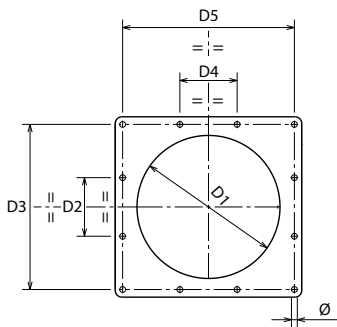

MODEL	D1	D2	D3	D4	D5	Ø
► RLS 1300/E-/EV C11	580	220	620	215	645	M20

PACKAGING

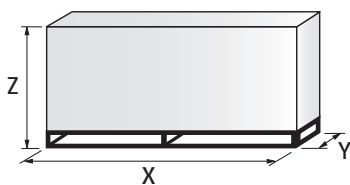

MODEL	X	Y	Z	kg
► RLS 1300/E-/EV C11	3000	1800	1750	1000

DUAL FUEL

Modulating Dual Fuel Burners

RLS 1300÷2000/E-/EV C11 SERIES

Overall dimensions (mm)

BURNER

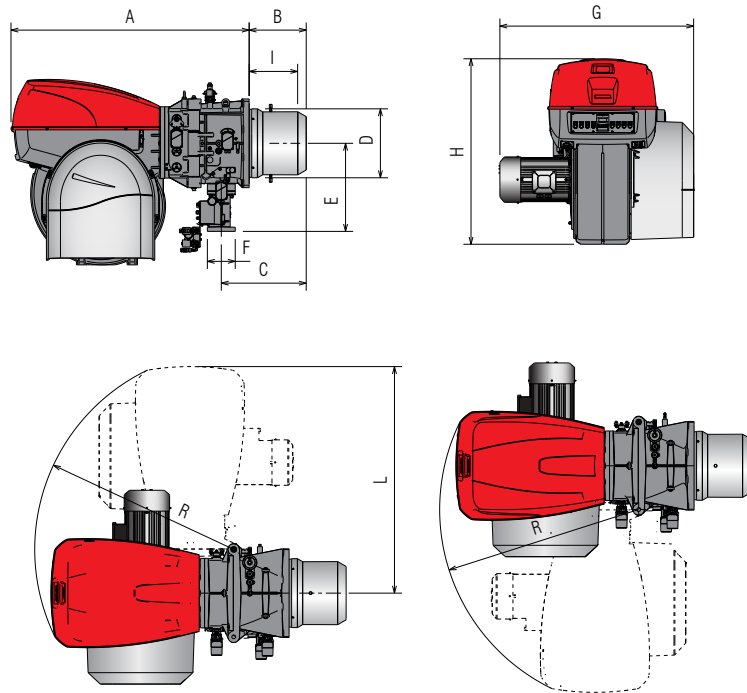

MODEL	A	B	C	D	E	F	G	H	I	L	R
► RLS 1600/E-/EV C11	1880	450	220	544	960	DN100	1560	1463	1464	1782	1564
► RLS 2000/E-/EV C11	1880	450	220	544	960	DN100	1530	1463	1464	1782	1564

BURNER - BOILER MOUNTING FLANGE

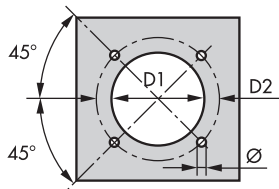

MODEL	D1	D2	Ø
► RLS 1600/E-/EV C11	580	645	M20
► RLS 2000/E-/EV C11	580	645	M20

PACKAGING

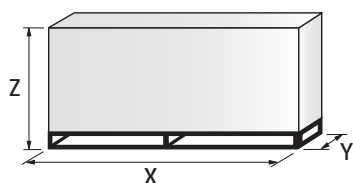

MODEL	X	Y	Z	kg
► RLS 1600/E-/EV C11	2600	1710	1700	1000
► RLS 2000/E-/EV C11	2600	1710	1700	1000

Modulating Dual Fuel Burners

RLS 1300÷2000/E-/EV C11 SERIES

RIELLO

Specification

DESIGNATION OF SERIES

Series: R										
Fuel: S Natural Gas										
L Light oil										
LS Light oil/Natural Gas										
N Heavy oil										
Size:										
Setting: /1 Single stage										
/B Two stage										
/M Modulating-Mechanical cam										
/E Electronic cam										
/P Proportioning air/gas valve										
/EV Electronic cam predisposed for variable speed (with inverter)										
/EVi Electronic cam with integrated inverter										
Emission: ... or C11					Class 1 EN267 - EN676					
MZ or C22					Class 2 EN267 - EN676					
BLU or C33					Class 3 EN267 - EN676					
MX or C23					Class 2 EN267 - Class 3 EN676					
C13					Class 2 EN267 - Class 3 EN676					
Head length: TC standard head										
TL extended head										
Flame control system: FS1 Standard/Intermittent (at least 1 stop every 24 h)										
FS2 Continuous (1 stop every 72 h)										
Electrical supply to the system:										
1/230/50		1/230V/50Hz								
3/230/50		3/230V/50Hz								
3/400/50		3/400V/50Hz								
3/230-400/50		3/230V/50Hz - 3N/400V/50Hz								
3/220/60		3/220V/60Hz								
3/380/60		3N/380V/60Hz								
3/220-380/60		3/220/60Hz - 3N/380V/60Hz								
Auxiliary voltage: 230/50										
110/50-60										
230V/50Hz										
110V/50-60Hz										
R	LS	2000	/E	C11	TC	FS1	3/400/50	230/50		
BASIC DESIGNATION					EXTENDED DESIGNATION					

DUAL FUEL

Modulating Dual Fuel Burners

RLS 1300÷2000/E-/EV C11 SERIES

Specification

STATE OF SUPPLY

Monoblock forced draught dual fuel burner, suitable for gas and gasoil combustion, with modulating operation, fully automatic, made up of:

- High performance fan with low sound emissions, forward curve blades
- Air suction circuit lined with sound-proofing material
- Air damper for air setting controlled by a high precision servomotor
- Air pressure switch
- Fan starting motor at 2900 rpm, three-phase 400/690 V with neutral, 50Hz
- Mobile combustion head, that can be set on the basis of required output, fitted with:
 - stainless steel end cone, resistant to corrosion and high temperatures
 - ignition electrodes
 - flame stability disk
- Ignition pilot burner
- Automatic regulator for gas and oil delivery, controlled by a high precision servomotor
- Maximum gas pressure switch, with pressure test point, for halting the burner in the case of over pressure on the fuel supply line
- Module for air/fuel setting and output modulation with incorporated PID control of temperature or pressure of the heat generator (for both RS/E and RS/EV models)
- Integrated light oil pump with dedicated motor on RLS 1300 model (separated pumping unit, to be ordered as accessory, for the RLS 1600 and RLS 2000 models).
- Oil delivery safety valves
- Maximum oil pressure switch
- Minimum oil pressure switch
- AZL Display Interface, for combustion system commissioning and monitoring, included
- Burner safety control included on Electronic Cam device
- IRD sensor flame detector
- Star/delta starter for the fan motor
- Main terminal supply board
- Volt-free contacts output relay
- Emergency button
- Fuel selector and enable signal to remote fuel selector
- Light signalling of main fuel valve open
- Voltage present warning lamp
- Light signalling fan motor and pump motor lockout
- Burner lockout warning lamp and reset switch
- Heat request light signalling
- Ventil motor contactor and thermal relay (RLS /E),
- Star/Delta starter (RLS /E)
- Off-automatic selector
- Pump motor contactor and thermal relay
- Burner opening hinge
- Lifting rings
- IP 55 electric protection level

Standard equipment:

- Gasket for gas train flange
- Gas flange fixing screws, M 16 x 50
- Thermal insulation screen
- M 20 x 70 for fixing the burner flange to the boiler
- M20 nuts to secure the burner to the boiler door
- Pressure switch (for leak detection control)
- Light oil flexible hoses
- Instruction handbook for installation, use and maintenance
- Spare parts catalogue.

Modulating Dual Fuel Burners

RLS 1300÷2000/E-/EV C11 SERIES

RIELLO

Available models

Burners

CODE	MODEL	HEAT OUTPUT			TOTAL ELECTRICAL POWER (kW)	CERTIFICATION	NOTE
		(kW)	LIGHT OIL (kg/h)	NATURAL GAS (Nm³/h)			
20081188	RLS 1300/E C11 TC FS1 3/400/50 230/50-60	1100/7500-13000	127/635-1102	110/750-1300	39,2 (oil) 34,5 (gas)	-	(1)(2)
20081187	RLS 1300/EV C11 TC FS1 3/400/50 230/50-60	1100/7500-13000	127/635-1102	110/750-1300	39,2 (oil) 34,5 (gas)	-	(1)(2)
20080870	RLS 1600/E C11 TC FS1 3/400/50 230/50-60	3065/9503-15560	259/802-1313	307/950-1556	48 (oil) 41,5 (gas)	-	(1)(2)
20080869	RLS 1600/EV C11 TC FS1 3/400/50 230/50-60	3065/9503-15560	259/802-1313	307/950-1556	48 (oil) 41,5 (gas)	-	(1)(2)
20080864	RLS 2000/E C11 TC FS1 3/400/50 230/50-60	4000/12000-19500	337/1013-1645	400/1200-1950	55,8 (oil) 49,3 (gas)	-	(1)(2)
20066055	RLS 2000/EV C11 TC FS1 3/400/50 230/50-60	4000/12000-19500	337/1013-1645	400/1200-1950	55,8 (oil) 49,3 (gas)	-	(1)(2)

Natural gas, net calorific value: 10 kWh/Nm³ - Density: 0,71 kg/Nm³

According to 2014/35/EU - 2014/30/EU - 2014/68/EU - 2006/42 CE Directives

(1) The maximum absorbed electric power is calculated considering the motor pump assembly

(2) The burners are factory set for FS1 operation 81 stop every 24 h) but they can be switched to FS2 operation (continuous - 1 stop every 72 h) by changing the parameters through the AZL unit menu.

Gas Trains

Code	Gas train				CQ KIT Code	Adapter Code	
	Model	∅	◆	◆		RLS 1300	RLS 1600 - 2000
3970223	MBC 3100/1 - FSM 40	DN 80	-	3010344	20130713	-	
20093449	MBC 3100/1 CQ FSM 40	DN 80	CQ	-	20130713	-	
3970224	MBC 5000/1 - FSM 80	DN 100	-	3010344	20130602	3090680	
20093452	MBC 5000/1 CQ FSM 80	DN 100	CQ	-	20130602	3090680	
3970149	CB 50100/1 - FSM 30	DN 100	-	3010344	20130602	3090680	
20015871	CB 50125/1 - FSM 30	DN 125	-	3010344	20130606	3090679	
20043047	DMV 50100/1 - FSM -0	DN 100	-	3010344	20130602	3090680	
20043049	DMV 50100/1 CQ FSM -2	DN 100	CQ	-	20130602	3090680	
20043050	DMV 50125/1 - FSM -0	DN 125	-	3010344	20130606	3090679	
20043052	DMV 50125/1 CQ FSM -2	DN 125	CQ	-	20130606	3090679	

Please see designation of Gas Train Series in the page before the Catalogue index.

- ◆ Gas valve leak detection control device:
- gas train not equipped with leak detection control device; this device can be ordered separately - see VPS column - and installed later.
CT gas train equipped with VPS leak detection control device for burners /M.
- CQ gas train with pressure switch for leak detection control of burners /E and /EV.
Additional pressure switch for leak detection control in combination with burners /E and /EV.
- Gas train not available or not suitable for the matching to the burner.
- Additional adapter not necessary, the gas train may be connected directly to the burner.

Modulating Dual Fuel Burners

RLS 1300÷2000/E-/EV C11 SERIES

Burner accessories

Accessories for checking temperature and pressure

PROBE



The relative RLS 1300-2000/E-/EV C11 models the PID regulator is integrated inside the LMV control box. The relative temperature or pressure probes fitted to the regulator must be chosen on the basis of the applications.

BURNER	PROBE TYPE	RANGE (°C) (bar)	KIT CODE
► All models	Temperature PT 100	-100 ÷ 500°C	3010110
► All models	Pressure 4 ÷ 20 mA	0 ÷ 2,5 bar	3010213
► All models	Pressure 4 ÷ 20 mA	0 ÷ 16 bar	3010214

Display and Operating Unit (AZL) for RS/E models



This tool is needed for combustion system commissioning and monitoring. The AZL, Display and Operating Unit, is included in RLS/E-/EV C11 models.

BURNER	KIT CODE
► All models *	3010469

* for Russian language only

PC Interface Software (ACS 450)

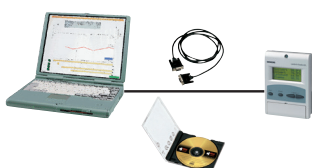

PC tool for convenient programming and burner settings, process visualization, data recording, selection of AZL language, software update AZL.

BURNER	KIT CODE
► All models	3010388

Sound proofing box

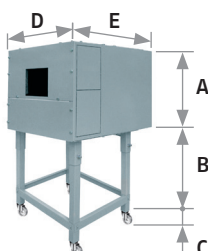

If noise emission needs reducing even further, sound-proofing boxes are available. When a lower "B" dimension is required, it is available the Box Support Kit code 20065135 which allows to reduce it at the fixed dimension of 55 mm. The sound-proofing boxes are not suitable for outdoor use.

BURNER	BOX TYPE	A (mm)	B (mm) min-max	C (mm)	D (mm)	E (mm)	[dB(A)] (*)	BOX CODE
► All models	C9							20108736

(*) Average noise reduction according to EN 15036-1 standard

Modulating Dual Fuel Burners

RLS 1300÷2000/E-/EV C11 SERIES

RIELLO

Burner accessories

Oxygen Control kit (QGO₂) for RS/EV series only



The QGO₂ is an oxygen analyzer with relevant probe which controls and supervises the residual oxygen content in exhaust gases.

BURNER	KIT CODE
► RLS 1300-1600-2000/EV C11	20045187*

* Installation outside the burner cover

Variable Speed Drive (VSD) for RLS/EV series only



The motor speed variation for the RLS/EV C11 burners series is obtained thanks to a frequency converter: variable speed drive (VSD), provided with a programming panel with start-up assistant. It always must be ordered with RLS/EV C11 series.

BURNER	MAX POWER (kW)	KIT CODE
► RLS 1300/EV C11	30	20163100
► RLS 1600/EV C11	37	20163105
► RLS 2000/EV C11	45	On demand

Flue Gases Sensor Bracket kit

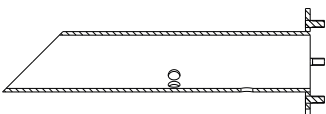

Available to be used as flue gas collector.

BURNER	KIT CODE
► RLS 1300-1600-2000/EV C11	20041585

Air/Combustion fume temperature sensor (for RLS/EV only)



The kit includes two temperature sensors: one for air and one for exhaust gas detection. They must be wired to oxygen control kit interface to allow the LMV 52 efficiency calculation. The value is showed on AZL display.

BURNER	ADJUSTMENT FIELD	PROBE TYPE	KIT CODE
► RLS 1300-1600-2000/EV C11	Temperature - 100 ... +500°C	PT 1000Ni1000	3010377

DUAL FUEL

Modulating Dual Fuel Burners

RLS 1300÷2000/E-/EV C11 SERIES

Burner accessories

Pump Unit Control Box Kit

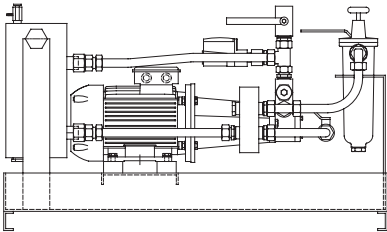

The RLS 1600 and RLS 2000 burners must be combined with a pumping unit suitable for the output to be produced.
The pump unit models available in combination with these burners are indicated in the table below.

BURNER	MODEL	FUEL	CONNECTION	OUTPUT AT 30 BAR	MOTOR (kW)	BURNER MAX. OUTPUT (kg/h)	CODE
▶ RLS/EV C11	SG 1000	Light oil	1"	2200 l/h	4	900	On demand
	SG 1250	Light oil	1"	3000 l/h	4	1250	On demand
	SG 1500	Light oil	1"	3600 l/h	5.5	1500	On demand
	SG 2000	Light oil	1"	4800 l/h	7.5	2000	On demand



Modulating Dual Fuel Burners

RLS 1300÷2000/E-/EV C11 SERIES

Gas train accessories

Adapters

In certain cases, an adapter must be fitted between the gas train and the burner, when the diameter of the gas train is different from the set diameter of the burner. Below are given the available adapters; please see on the Gas Train list the correct adapter codes to select.

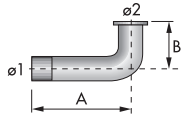
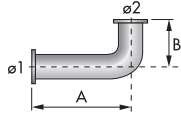
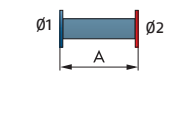
ADAPTER	DIMENSIONS				ADAPTER CODE
	Ø1 DN	Ø2 DN	A mm	B mm	
 1" 1/2" 2"	-	-	65	-	20064220
 2" 2"	-	-	65	-	20042324
 DN 80 2" 1/2" 2"	-	-	300	-	3000826
	2"	65 / 80	230	230	20064169
	2"	65 / 80	780	230	20068062
	2"	65 / 80	780	230	20068058
	65	65 / 80	230	230	20059330
	80	65 / 80	230	230	20059331
	100	65 / 80	230	230	20059332
	125	65 / 80	245	230	20059333
	2"	65 / 80	230	375	20066253
	65	65 / 80	230	375	20066263
	80	65 / 80	230	375	20066268
	100	65 / 80	230	375	20066278
	125	65 / 80	245	375	20066284
	65	80	400	-	3010221
	80	80	400	-	3010222
	100	80	400	-	3010223
	125	80	320	-	3010224
	65	65	800	-	20065924
	80	80	800	-	20065937
	100	100	800	-	20065960
	125	125	800	-	20065968
	100	100	320	174	3090680
	100	100	350	350	20130616
	125	100	350	350	20130617
	150	100	320	320	20130039
	100	80	350	350	20130602
	125	80	350	350	20130606
	80	80	350	350	20130713

Modulating Dual Fuel Burners

RLS 1300÷2000/E-/EV C11 SERIES

Gas train accessories

Stabiliser spring



To vary the pressure range of the gas train stabilisers, accessory springs are available. The following table shows these accessories with their application range. Please refer to the technical manual for the correct choice of spring.

GAS TRAIN	SPRING COLOUR	SPRING PRESSURE RANGE mbar	SPRING CODE
▶ MBC 1900/1 - 3100/1 MBC 5000/1	White	4 - 20	3010381
	Red	20 - 40	3010382
	Black	40 - 80	3010383
	Green	80 - 150	3010384
▶ CB 5065/1 - 5080/1	Red	25 - 55	3010133
	Black	60 - 110	3010135
	Pink	100 - 150	3090456
	Grey	140 - 200	3090992
▶ CB 50100/1	Red	25 - 55	3010134
	Black	60 - 110	3010136
	Pink	100 - 150	3090489
	Grey	140 - 200	3092174
▶ CB 50125/1	Red	25 - 55	3010315
	Yellow	30 - 70	3010316
	Black	60 - 110	3010317
	Pink	100 - 150	3010318

PVP (Pressure Valve Proving) kit

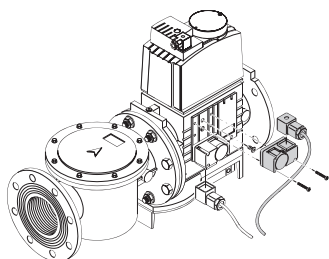

The seal control function is included on Burner Digital Management System, it is only necessary to add the PVP kit on the gas train. The PVP is included as standard equipment on RLS 1300-1600-2000 models.

BURNER	KIT CODE
▶ MB - CB - MBC type	3010344

ENNE/EMME SERIES

The ENNE/EMME 1400–4500 series of burners covers a firing range from 814 to 5000 kW.

They have been designed for high output users and they are suitable for matching with every kind of boilers, with normal or pressurized combustion chamber.

Operation can be “two stage progressive” or, alternatively, “modulating” with the installation of a PID logic regulator and respective probes. Two fuel options are available: only gas and only heavy oil, thus settable by a manual switch. Heavy oil circuit is fitted with his own electric motor: this permits pump stop during gas operation preventing danger of pumping seizure and avoiding oil circulation. A wide range of accessories and gas trains suitable to the burners guarantee an elevated working flexibility.

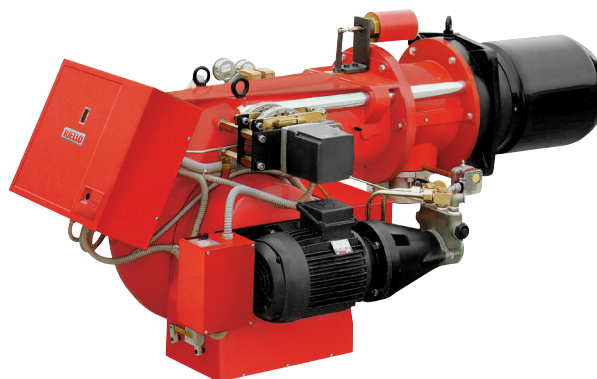

ENNE/EMME 1400	407/814 ÷ 1628 kW
ENNE/EMME 2000	581/1163 ÷ 2325 kW
ENNE/EMME 3000	872/1744 ÷ 3488 kW
ENNE/EMME 4500	1163/2325 ÷ 5000 kW

FIRING RATES

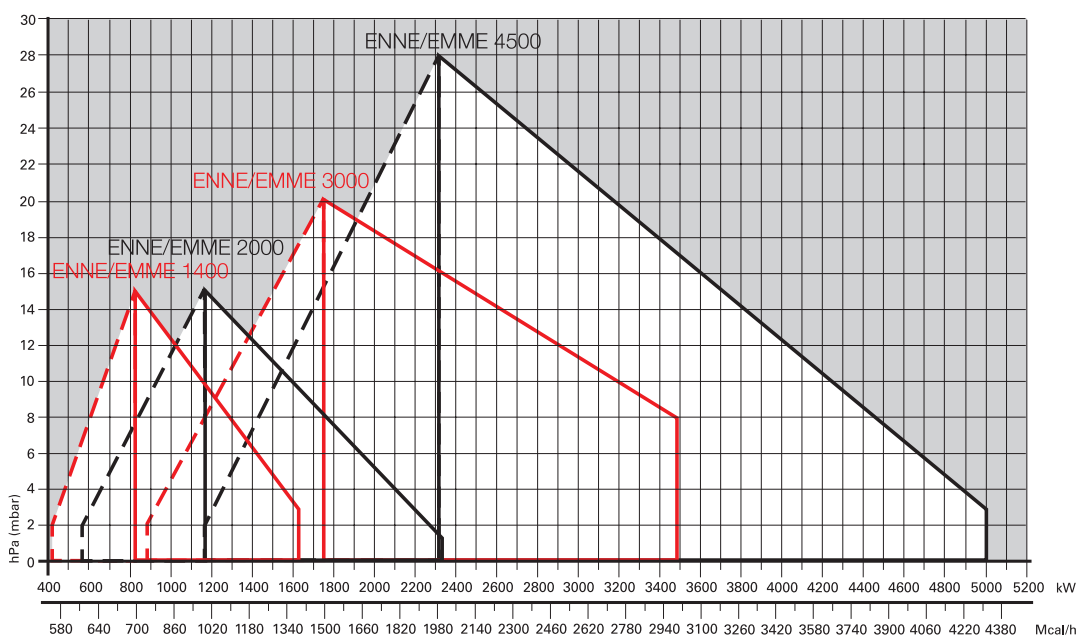

Useful working field for choosing the burner

Modulation range

Test conditions conforming to EN267- EN676
 Temperature: 20°C
 Pressure: 1013,5 mbar
 Altitude: 0 m a.s.l.

Modulating Dual Fuel Burners

ENNE/EMME SERIES

Overall dimensions (mm)

BURNER

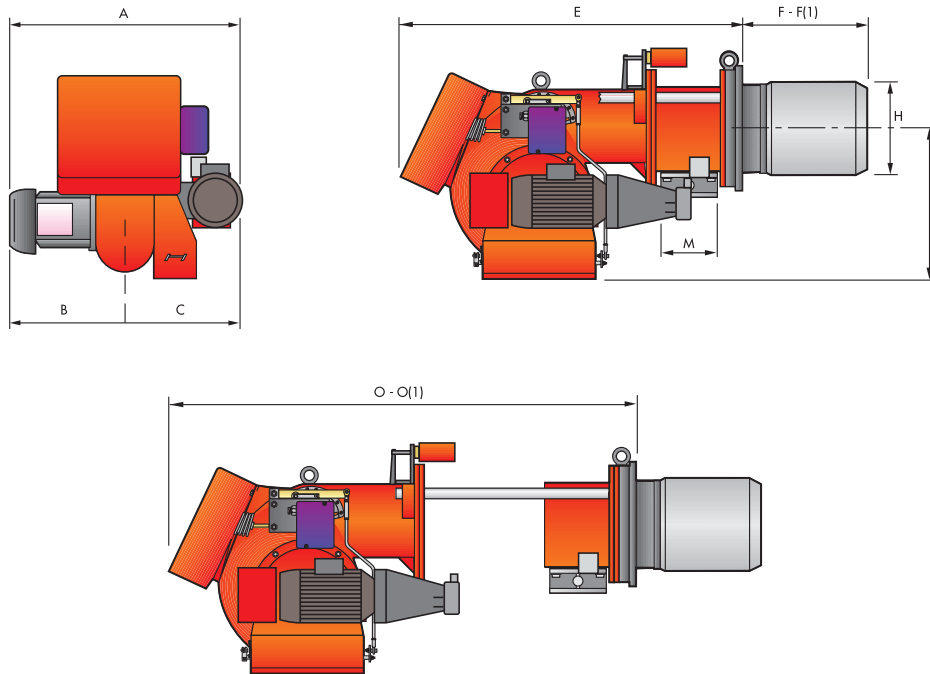

MODEL	A	B	C	E	F - F(1)	H	I	M	O - O(1)
▶ ENNE/EMME 1400	940	376	564	1090	385 - 495	250	467	2"	1475 - 1585
▶ ENNE/EMME 2000	960	396	564	1090	385 - 495	260	467	DN80	1475 - 1585
▶ ENNE/EMME 3000	1000	447	553	1320	476 - 606	336	525	DN80	1796 - 1926
▶ ENNE/EMME 4500	1061	508	553	1320	476 - 606	336	525	DN80	1796 - 1926

(1) Length with extended combustion head

BURNER - BOILER MOUNTING FLANGE

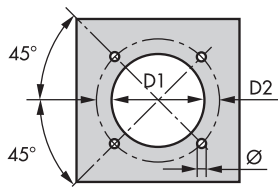

MODEL	D1	D2	Ø
▶ ENNE/EMME 1400	255	368	M16
▶ ENNE/EMME 2000	265	368	M16
▶ ENNE/EMME 3000	340	438	M20
▶ ENNE/EMME 4500	340	438	M20

PACKAGING

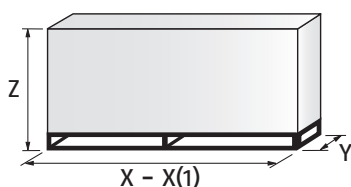

MODEL	X - X(1)	Y	Z	Kg
▶ ENNE/EMME 1400	1740 - 1740	990	950	265
▶ ENNE/EMME 2000	1740 - 1740	990	950	265
▶ ENNE/EMME 3000	2040 - 2040	1180	1125	280
▶ ENNE/EMME 4500	2040 - 2040	1180	1125	500

(1) Length with extended combustion head

Specification

DESIGNATION OF SERIES

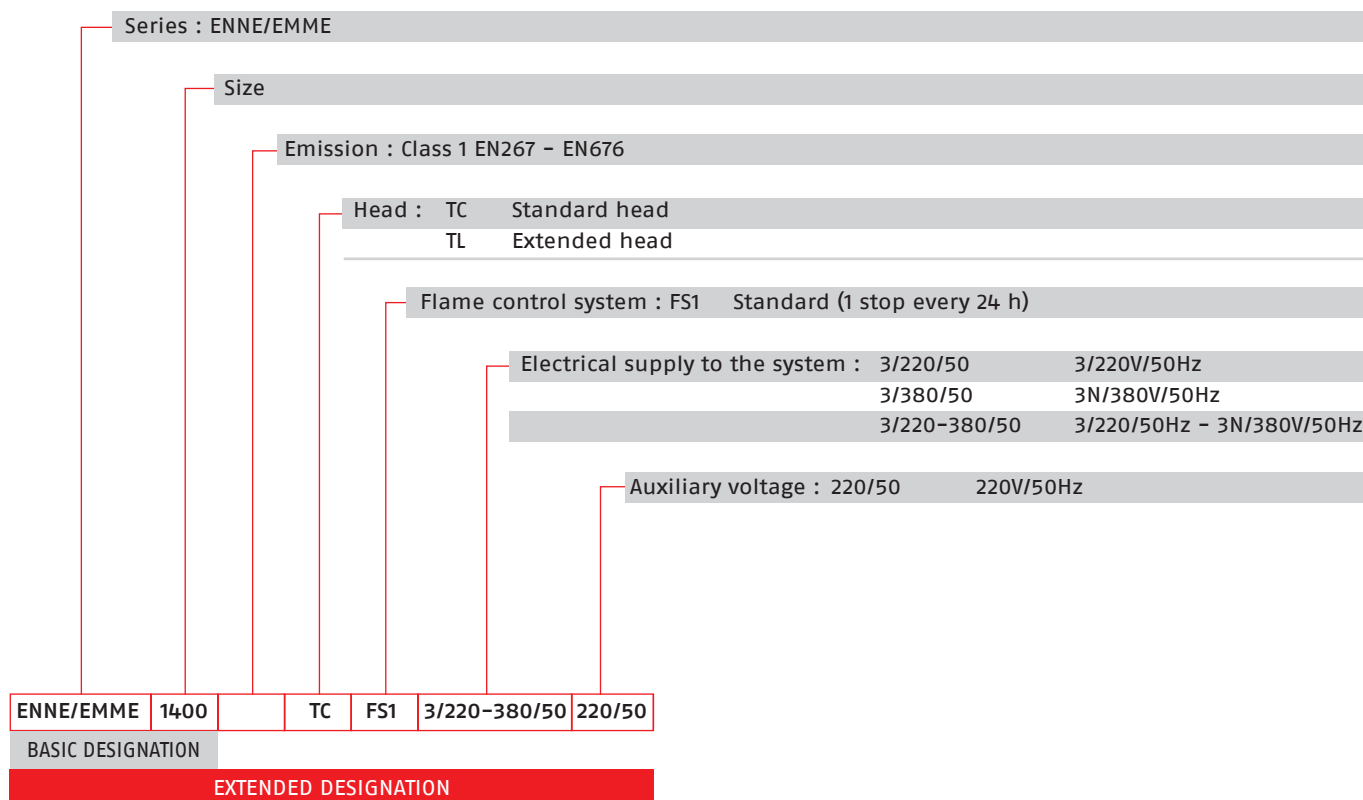

Modulating Dual Fuel Burners

ENNE/EMME SERIES

Specification

STATE OF SUPPLY

Monoblock forced draught dual fuel burner, two stage progressive or modulating operation with a kit, made up of:

- Air suction circuit
- Fan with forward curved blades
- Air damper for setting and butterfly valve for regulating fuel output controlled by a servomotor
- Combustion head, that can be set on the basis of required output
- Maximum gas pressure switch
- Minimum air pressure switch
- Fan electrical motor
- Dedicated 1400 rpm low speed pump motor
- Gears pump for high pressure fuel supply, fitted with:
 - filter
 - pressure regulator
 - connections for installing a pressure gauge and a a vacuumeter
 - internal by-pass for single pipe installation
- Preheater unit
- Valve unit with a double oil safety valve on the output circuit and safety valve on the return circuit
- Heavy oil heating cartridges factory installed on pump and valves group
- UV photocell for flame detection
- Flame inspection window
- Slide bars for easier installation and maintenance
- Protection filter against radio interference
- IP X0D (IP 40) protection level.

Standard equipment:

- 1 gas train flange
- 12 screws for fixing the burner flange to the boiler
- 1 insulating screen
- 2 flexible hoses for connection to the oil supply circuit
- 2 nipples for connection to the pump
- 4 wiring looms fittings for electrical connections
- 2 pin extensions
- 8 washers
- Instruction handbook for installation, use and maintenance
- Spare parts catalogue.

Available models

Burners

CODE	MODEL	(kW)	HEAT OUTPUT		TOTAL ELECTRICAL POWER (kW)	CERTIFICATION	NOTE
			LIGHT OIL (kg/h)	NATURAL GAS (Nm ³ /h)			
20169213	ENNE/EMME 1400 TC FS1 3/230-400/50 230/50	407/814-1628	35/70-140	41/81-163	6,5 (oil) 5,2 (gas)		(3)
20169214	ENNE/EMME 2000 TC FS1 3/230-400/50 230/50	581/1163-2325	50/100-200	58/116-233	6,6 (oil) 5,3 (gas)		(3)
20169215	ENNE/EMME 2000 TL FS1 3/230-400/50 230/50	581/1163-2325	50/100-200	58/116-233	6,6 (oil) 5,3 (gas)		(3)
20169216	ENNE/EMME 3000 TC FS1 3/400/50 230/50	872/1744-3488	75/150-300	87/174-349	10,6 (oil) 12,4 (gas)		(2)(3)
20169217	ENNE/EMME 4500 TC FS1 3/400/50 230/50	1163/2325-5000	100/200-430	116/233-500	18,7 (oil) 16,9 (gas)		(1)(3)

(1) Star delta starter.

(2) For the 3/230/50 version use the 220 - 230 V conversion kit (see the burner accessories paragraph)

(3) with RFGO control box

Net calorific value light oil: 11,8 kWh/kg; 10.200 kcal/kg - Viscosity up to 20°C (150 mm²/s, cSt), Type BUNKER B / USA n° 5 (with separate 1400 rpm low speed pump, heavy oil heating cartridges factory installed on pump and valves group).

Net calorific value G20 gas: 10 kWh/Nm³; 8.600 kcal/Nm³ - Density: 0,71 kg/Nm³.

The burners of ENNE/EMME series are in according to 2016/426/EU - 2014/30/EU - 2014/35/EU - 2006/42 CE Directive and EN 267-676 Norm.

Due to the improvement applied on the technical specification of some products, some burner codes will change during year 2019. The table below summarizes the correspondence between the previous and the new code.

MODEL			NEW CODE	OLD CODE
ENNE/EMME 1400	TC	FS1 3/230-400/50 230/50	20169213 (5)	3486701
ENNE/EMME 2000	TC	FS1 3/230-400/50 230/50	20169214 (5)	3487801
ENNE/EMME 2000	TC	FS1 3/230-400/50 230/50	20169215 (5)	3487802
ENNE/EMME 3000	TC	FS1 3/400/50 230/50	20169216 (5)	3488801
ENNE/EMME 4500	TC	FS1 3/400/50 230/50	20169217 (5)	3489203

Modulating Dual Fuel Burners

ENNE/EMME SERIES

Available models

Gas Trains

CODE	GAS TRAIN		C.T.	VPS CODE	ADAPTER CODE			
	MODEL	Ø			N/M 1400	N/M 2000	N/M 3000	N/M 4500
3970256*	MB 412/1 - RT 52	Rp 1" 1/4	-	3010123	3010126	●	●	●
3970144*	MB 412/1 - RT 20	Rp 1" 1/4	-	3010123		●	●	●
3970197**	MB 412/1 CT RT 20	Rp 1" 1/4	◆	-		●	●	●
3970231*	MB 412/1 - RSM 20	Rp 1" 1/4	-	3010123		●	●	●
3970180*	MB 415/1 - RT 30	Rp 1" 1/2	-	3010123	3000843	20064220 + 3010128		●
3970198**	MB 415/1 CT RT 30	Rp 1" 1/2	◆	-				●
3970250*	MB 415/1 - RT 52	Rp 1" 1/2	-	3010123				●
3970253**	MB 415/1 CT RT 52	Rp 1" 1/2	◆	-				●
3970232*	MB 415/1 - RSM 30	Rp 1" 1/2	-	3010123	□	20042324 + 3010128		●
3970181*	MB 420/1 - RT 30	Rp 2"	-	3010123				●
3970182**	MB 420/1 CT RT 30	Rp 2"	◆	-				●
3970257*	MB 420/1 - RT 52	Rp 2"	-	3010123				●
3970252**	MB 420/1 CT RT 52	Rp 2"	◆	-	□	20042324 + 3010128		●
3970233*	MB 420/1 - RSM 30	Rp 2"	-	3010123	□			●
3970234**	MB 420/1 CT RSM 30	Rp 2"	◆	-	□			●
3970221*	MBC 1200/1 - RSM 60	Rp 2"	-	3010123	□	20042324 + 3010128		
3970225**	MBC 1200/1 CT RSM 60	Rp 2"	◆	-	□			
3970222*	MBC 1900/1 - FSM 40	DN 65	-	3010123	3000825	3000831		
3970226**	MBC 1900/1 CT FSM 40	DN 65	◆	-				
3970223*	MBC 3100/1 - FSM 40	DN 80	-	3010123	3000826	3000832		
3970227**	MBC 3100/1 CT FSM 40	DN 80	◆	-				
3970224*	MBC 5000/1 - FSM 80	DN 100	-	3010123	●	●	3010127	
3970228**	MBC 5000/1 CT FSM 80	DN 100	◆	-	●			
3970145*	CB 512/1 - RSM 30	Rp 1" 1/2	-	3010123	3000843	20064220 + 3010128		●
20045589**	CB 512/1 CT RSM 30	Rp 1" 1/2	◆	-				●
3970146*	CB 520/1 - RSM 30	Rp 2"	-	3010123	□	20042324 + 3010128		
3970160**	CB 520/1 CT RSM 30	Rp 2"	◆	-	□			
20044659*	CB 525/1 - RSM 30	Rp 2"	-	3010123	□			
20044660**	CB 525/1 CT RSM 30	Rp 2"	◆	-	□			
3970147*	CB 5065/1 - FSM 30	DN 65	-	3010123	3000825	3000831		
3970161**	CB 5065/1 CT FSM 30	DN 65	◆	-				
3970148*	CB 5080/1 - FSM 30	DN 80	-	3010123	3000826	3000832		
3970162**	CB 5080/1 CT FSM 30	DN 80	◆	-				
3970149*	CB 50100/1 - FSM 30	DN 100	-	3010123	3010370 + 3000826	3010127		
3970163**	CB 50100/1 CT FSM 30	DN 100	◆	-				
20015871*	CB 50125/1 - FSM 30	DN 125	-	3010123	3010224 + 3000826	3090940		
3970196**	CB 50125/1 CT FSM 30	DN 125	◆	-				

Please see designation of Gas Train Series in the page before the Catalogue index.

* 230V/50Hz -220V/60Hz electrical supply.

** 230V/50Hz electrical supply.

The valve seal control device is compulsory (conforming to EN 676) on gas trains to burners with a maximum output over 1200 kW.

To select the gas train please refer to the technical data leaflet and/or instruction manual.

C.T. Gas valve leak detection control device:

- gas train not equipped with leak detection control device; this device can be ordered separately - see VPS column - and installed later.
- ◆ gas train equipped with leak detection control device.

VPS Valve leak detection control device. Supplied separately from the gas train (please see Gas train accessories paragraph for both 50 Hz and 60 Hz codes).

● Not available.

□ Additional adapter not necessary, the gas train may be connected directly to the burner.

Burner accessories

Nozzles type B5-AA 45°



The nozzles must be ordered separately. The following table shows the features and codes on the basis of the maximum required fuel output.

NOTE: each burner needs N° 1 nozzle.

BURNER	RATED DELIVERY (kg/h)	NOZZLE CODE (1)	NOZZLE CODE (2)
▶ ENNE/EMME 1400	70	3009203	3045426
▶ ENNE/EMME 1400	80	3009205	3045427
▶ ENNE/EMME 1400	90	3009207	3045428
▶ ENNE/EMME 1400 - 2000	100	3009209	3045430
▶ ENNE/EMME 1400 - 2000	125	3009211	3045432
▶ ENNE/EMME 1400 - 2000 - 3000	150	3009213	3045434
▶ ENNE/EMME 2000 - 3000	175	3009215	3045436
▶ ENNE/EMME 2000 - 3000 - 4500	200	3009800	3045438
▶ ENNE/EMME 3000 - 4500	225	3009801	3045440
▶ ENNE/EMME 3000 - 4500	250	3009802	3045442
▶ ENNE/EMME 3000 - 4500	275	3009803	3045444
▶ ENNE/EMME 3000 - 4500	300	3009804	3045446
▶ ENNE/EMME 4500	325	3009805	3045448
▶ ENNE/EMME 4500	350	3009806	3045450
▶ ENNE/EMME 4500	375	3009807	3045452
▶ ENNE/EMME 4500	400	3009808	3045454
▶ ENNE/EMME 4500	425	3009809	3045455
▶ ENNE/EMME 4500	450	3009810	3045456

(1) Nozzles Bergonzo B5 45° - with "AA" needle code.

(2) Nozzles Fluidics W2 45° - with "AA" needle code.

Spacer kit

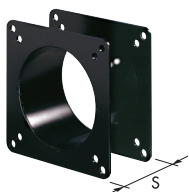

If burner head penetration into the combustion chamber needs reducing, varying thickness spacers are available, as given in the following list.

BURNER	SPACER THICKNESS S (mm)	KIT CODE
▶ ENNE/EMME 1400 - 2000	102	3000722
▶ ENNE/EMME 3000 - 4500	130	3000751

Modulating Dual Fuel Burners

ENNE/EMME SERIES

Burner accessories

Sound proofing box

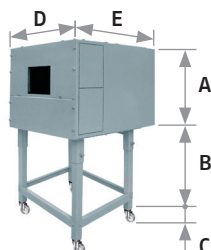

If noise emission needs reducing even further, sound-proofing boxes are available. When a lower "B" dimension is required, it is available the Box Support Kit code 20065135 which allows to reduce it at the fixed dimension of 55 mm. The sound-proofing boxes are not suitable for outdoor use.

BURNER	BOX TYPE	A (mm)	B (mm) min-max	C (mm)	D (mm)	E (mm)	[dB(A)] (*)	BOX CODE
▶ ENNE/EMME 1400-2000 ENNE/EMME 3000-4500	C7	1255	160 - 980	110	1140	1345	10	3010376

(*) Average noise reduction according to EN 15036-1 standard

Accessories for modulating operation



To obtain modulating operation, the ENNE/EMME series of burners requires a regulator. For remote setpoint use RWF 55.

BURNER	REGULATOR TYPE	REGULATOR CODE
▶ ENNE/EMME 1400 - 2000 - 3000 - 4500	RWF 50.2	20100018
	RWF 55.5	20101965

The relative temperature or pressure probes fitted to the regulator, must be chosen on the basis of the application.

BURNER	PROBE TYPE	RANGE (°C) (bar)	PROBE CODE
▶ ENNE/EMME 1400 - 2000 ENNE/EMME 3000 - 4500	Temperature PT 100	-100 ÷ 500°C	3010110
	Pressure 4 ÷ 20 mA	0 ÷ 2,5 bar	3010213
	Pressure 4 ÷ 20 mA	0 ÷ 16 bar	3010214
	Pressure 4 ÷ 20 mA	0 ÷ 25 bar	3090873

Depending on the servomotor fitted to the burner, a three-pole potentiometer (1000 Ω) can be installed to check the position of the servomotor.

BURNER	POTENTIOMETER KIT CODE
▶ ENNE/EMME 1400 - 2000 - 3000 - 4500	20096322



Burner accessories

LPG kit

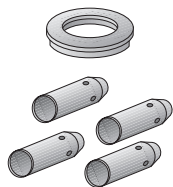

For burning LPG gas, a special kit is available to be fitted to the combustion head on the burner, as given in the following table.

BURNER	KIT CODE FOR STANDARD HEAD (*)	KIT CODE FOR EXTENDED HEAD (*)
▶ ENNE/EMME 1400 - 2000	3010063	3010063
▶ ENNE/EMME 3000	3090223	3090223
▶ ENNE/EMME 4500	3090937	3090937

(*) without CE certification

Self-cleaning filter



For cleaning heavy oil from dirty particles and impurities, it is equipped with a thermostatic heater for oil with 60°E viscosity at 50°C.

FILTER TYPE	FILTERING DEGREE (µm)	FILTER CODE
▶ Ø = 1"1/2 (60°E at 50°C)	300	3010022

HEATER / THERMOSTAT TYPE	HEATER / THERMOSTAT CODE
▶ Thermostatic heater with LED	3010050

Degasing unit



In modulating burner, gas separator bottle connects the burner circuit to the main ring circuit. It allows to recover heat in excess by discharge of the gas from the return circuit.

BURNER	DEGASING UNIT CODE
▶ ENNE/EMME 1400 - 2000	3000748
▶ ENNE/EMME 3000 - 4500	3010012

220-230 V conversion kit

This kit is required to convert the 380-400 V models into the 220 or 230 V version.

BURNER	SUPPORT CODE
▶ ENNE/EMME 3000 - 4500	20163347







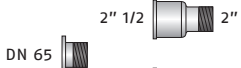
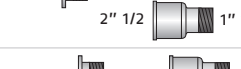

Modulating Dual Fuel Burners

ENNE/EMME SERIES

Gas train accessories

Adapters

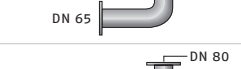
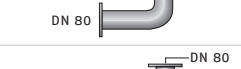
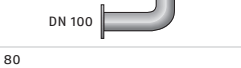
In certain cases, an adapter must be fitted between the gas train and the burner, when the diameter of the gas train is different from the set diameter of the burner. Below are given the available adapters; please see on the Gas Train list the correct adapter codes to select.

ADAPTER	LENGTH mm	ADAPTER CODE
 DN 65 2" 1/2 2"	300	3000825
 DN 65 2" 1/2 1" 1/2		
 DN 80 2" 1/2 2"	300	3000826
 1" 1/2 2"	35	3000843
 1" 1/4 2"	35	3010126
 DN 100 DN 80	50	3010370
 1" 1/2 2"	65	20064220
 2" 2"	65	20042324
 DN 65 DN 80	320	3000831
 DN 80 DN 80	320	3000832
 DN 100 DN 80	320	3010127
 DN 80 DN 65 2" 1/2 2"	540	3010128

Gas train accessories

Stabiliser spring



To vary the pressure range of the gas train stabilisers, accessory springs are available. The following table shows these accessories with their application range. Please refer to the technical manual for the correct choice of spring.

GAS TRAIN	SPRING COLOUR	SPRING PRESSURE RANGE mbar	SPRING CODE
▶ MBC 1900/1 - 3100/1 MBC 5000/1	White	4 - 20	3010381
	Red	20 - 40	3010382
	Black	40 - 80	3010383
	Green	80 - 150	3010384
▶ CB 512/1	Red	25 - 55	3010131
	Black	60 - 110	3010157
	Pink	90 - 150	3090486
▶ CB 520/1 - 525/1	Red	25 - 55	3010132
	Black	60 - 110	3010158
	Pink	100 - 150	3090487
▶ CB 5065/1 - 5080/1	Red	25 - 55	3010133
	Black	60 - 110	3010158
	Pink	100 - 150	3090487
	Grey	140 - 200	3090992
▶ CB 50100/1	Red	25 - 55	3010134
	Black	60 - 110	3010136
	Pink	100 - 150	3090489
	Grey	140 - 200	3092174
▶ CB 50125/1	Red	25 - 55	3010315
	Yellow	30 - 70	3010316
	Black	60 - 110	3010317
	Pink	100 - 150	3010318

Seal control kit



To test the valve seals on the gas train, a special "seal control kit" is available. The valve seal control device is compulsory (EN 676) on gas trains to burners with a maximum output over 1200 kW. The seal control is type VPS 504.

GAS TRAIN	KIT CODE for 50 Hz operation	KIT CODE for 60 Hz operation
▶ MB/1 type	3010123	20168805
▶ MBC/1 type	3010123	20168805
▶ CB/1 type	3010123	20168805

RX 180÷1000 S/PV ULN SERIES

In order to comply the increasing demand of very low NOx emissions, Riello has developed a new product range for medium and high power combustion, based on PREMIX low emission technology, suitable to achieve the most restrictive emission limits.

Riello RX S/PV ULN Premix Range from 30 to 970 is based on a platform with Brushless Motors, which provides high modulation ratios and low pollution emissions, representing the ideal solution for condensing boilers and industrial processes.

In the RX S/PV ULN range, the gas and air are delivered into the fan simultaneously and the mixing occurs inside the aspiration circuit; the ventilation structures are airtight in order to avoid air-gas leaks.

The Ultra Low NOx emission performance is achieved while maintaining high reliability of operation; a high ignition reliability is assured by a Pilot Ignition system.

All burner's components are integrated in order to facilitate and make extremely easy the installation and maintenance.



RX 180 S/PV ULN	30 ÷ 160	kW
RX 250 S/PV ULN	40 ÷ 225	kW
RX 360 S/PV ULN	60 ÷ 325	kW
RX 500 S/PV ULN	80 ÷ 440	kW
RX 700 S/PV ULN	140 ÷ 630	kW
RX 850 S/PV ULN	170 ÷ 790	kW
RX 1000 S/PV ULN	180 ÷ 970	kW

Ultra Low NOx Modulating Premix Gas Burners

RX 180÷1000 S/PV ULN SERIES

FIRING RATES

RX 180-250-360-500 S/PV ULN

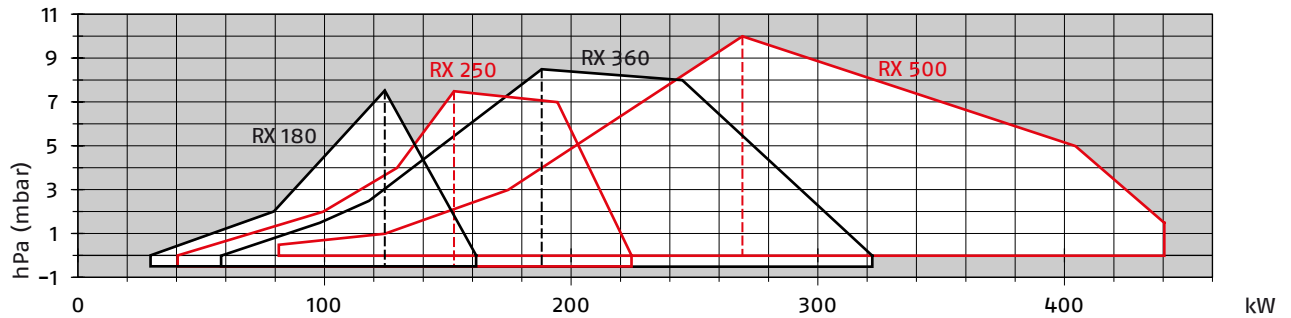

RX 700-850-1000 S/PV ULN

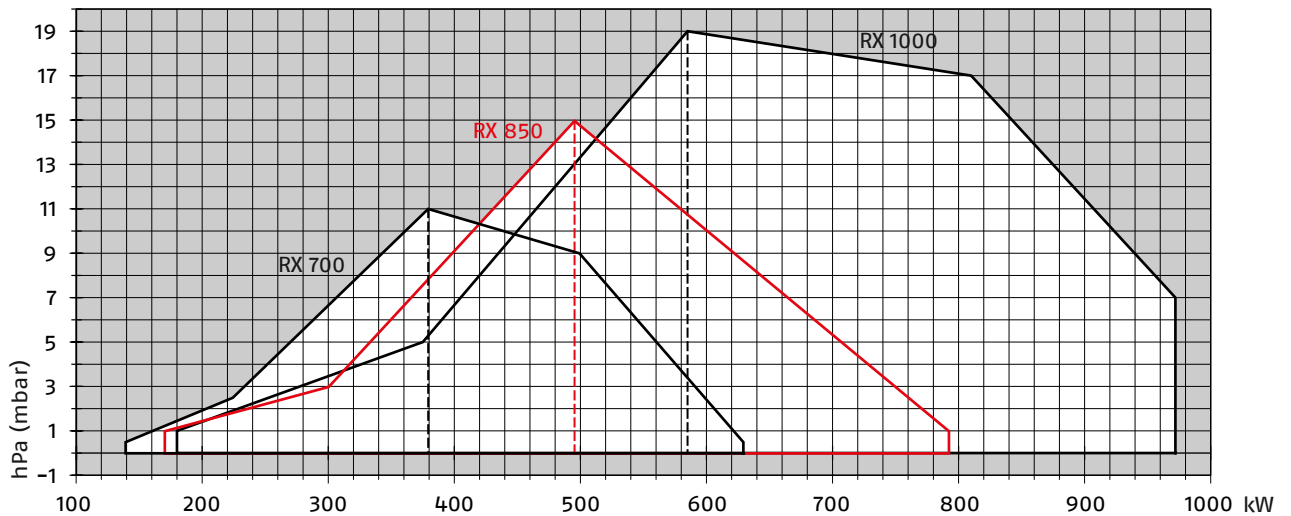

Useful working field for choosing the burner

Test conditions conforming to EN676

Temperature: 20°C

Pressure: 1013,5 mbar

Altitude: 0 m a.s.l.

Please note: it is important to be aware that in order to achieve an ULTRA Low NOx emission performance, it is required to work with a high excess air; as consequence the combustion chamber back pressure could increase up to roughly 30% more.

RX 180÷1000 S/PV ULN SERIES

Overall dimensions (mm)

BURNER

RX 180-250 S/PV ULN
RX 360 S/PV ULN

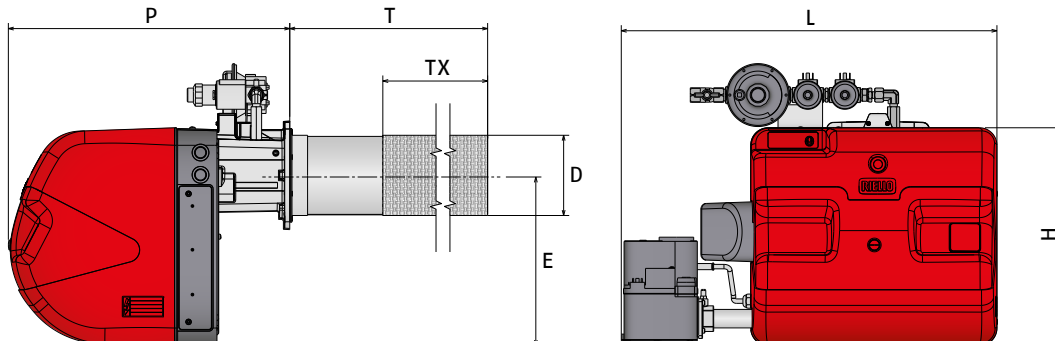

MODEL	H	L	P	T	TX	D	E
▶ RX 180 S/PV ULN	390	640	503	465	320	119	306
▶ RX 250 S/PV ULN	390	640	503	465	320	119	306
▶ RX 360 S/PV ULN	390	675	503	635	442	144	306

TX: flame zone length; the non combustion area (T-TX) must be greater than the thickness of the boiler door complete with refractory.

RX 500 S/PV ULN

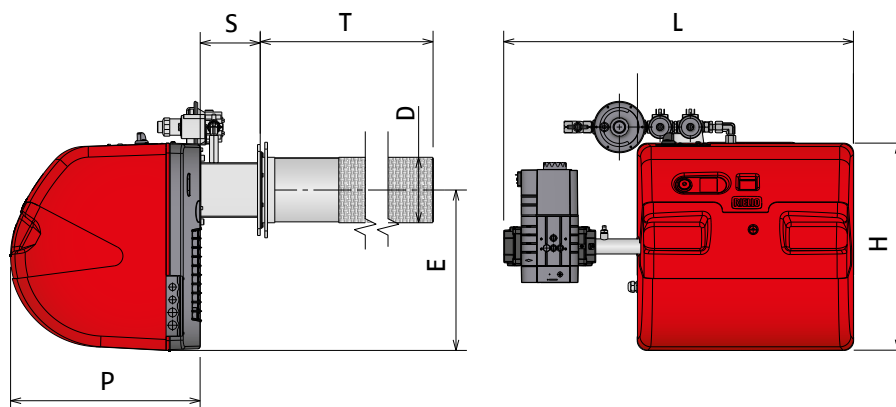

RX 700-850-1000 S/PV ULN

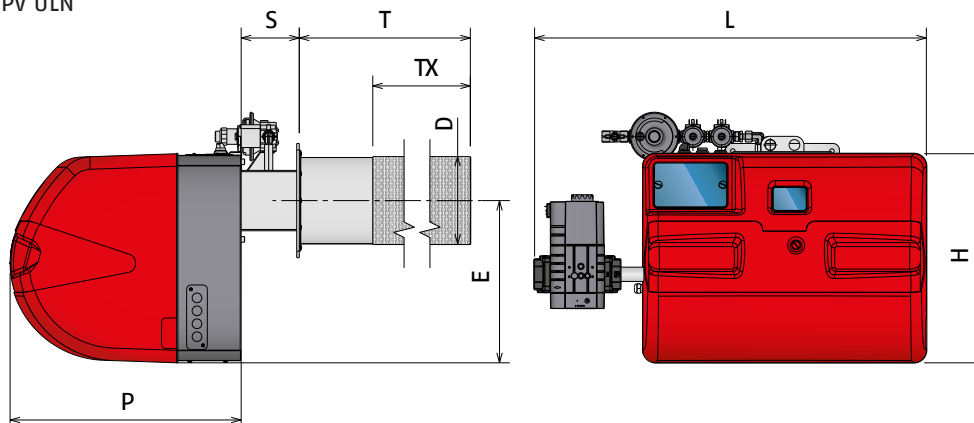

MODEL	H	L	P	T	TX	D	E	S
▶ RX 500 S/PV ULN	456	770	550	635	442	144	353	-
▶ RX 700 S/PV ULN	490	910	520	540	367	200	370	135
▶ RX 850 S/PV ULN	490	910	520	660	460	200	370	135
▶ RX 1000 S/PV ULN	490	910	520	660	460	200	370	135

Ultra Low NOx Modulating Premix Gas Burners

RX 180÷1000 S/PV ULN SERIES

Overall dimensions (mm)

BURNER - BOILER MOUNTING FLANGE

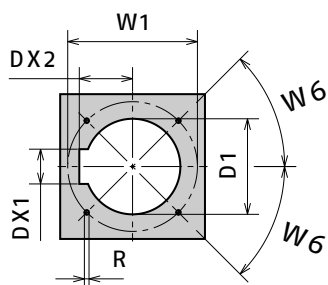

MODEL	D1	W1	R	DX2	DX1	W6
▶ RX 180 S/PV ULN	163	224	M8	94	68	45°
▶ RX 250 S/PV ULN	163	224	M8	94	68	45°
▶ RX 360 S/PV ULN	163	224	M8	94	68	45°
▶ RX 500 S/PV ULN	163	224	M8	100	68	45°
▶ RX 700 S/PV ULN	240	75 - 325	M10	135	75	45°
▶ RX 850 S/PV ULN	240	75 - 325	M10	135	75	45°
▶ RX 1000 S/PV ULN	240	75 - 325	M10	135	75	45°

PACKAGING

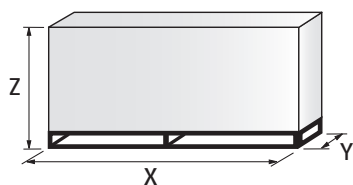

MODEL	X	Y	Z	kg
▶ RX 180 S/PV ULN	730	530	550	33
▶ RX 250 S/PV ULN	730	530	550	33
▶ RX 360 S/PV ULN	1190	530	550	35
▶ RX 500 S/PV ULN	1280	530	565	43
▶ RX 700 S/PV ULN	1420	580	695	50
▶ RX 850 S/PV ULN	1420	580	695	50
▶ RX 1000 S/PV ULN	1420	580	695	60

RX 180÷1000 S/PV ULN SERIES

Specification

DESIGNATION OF SERIES

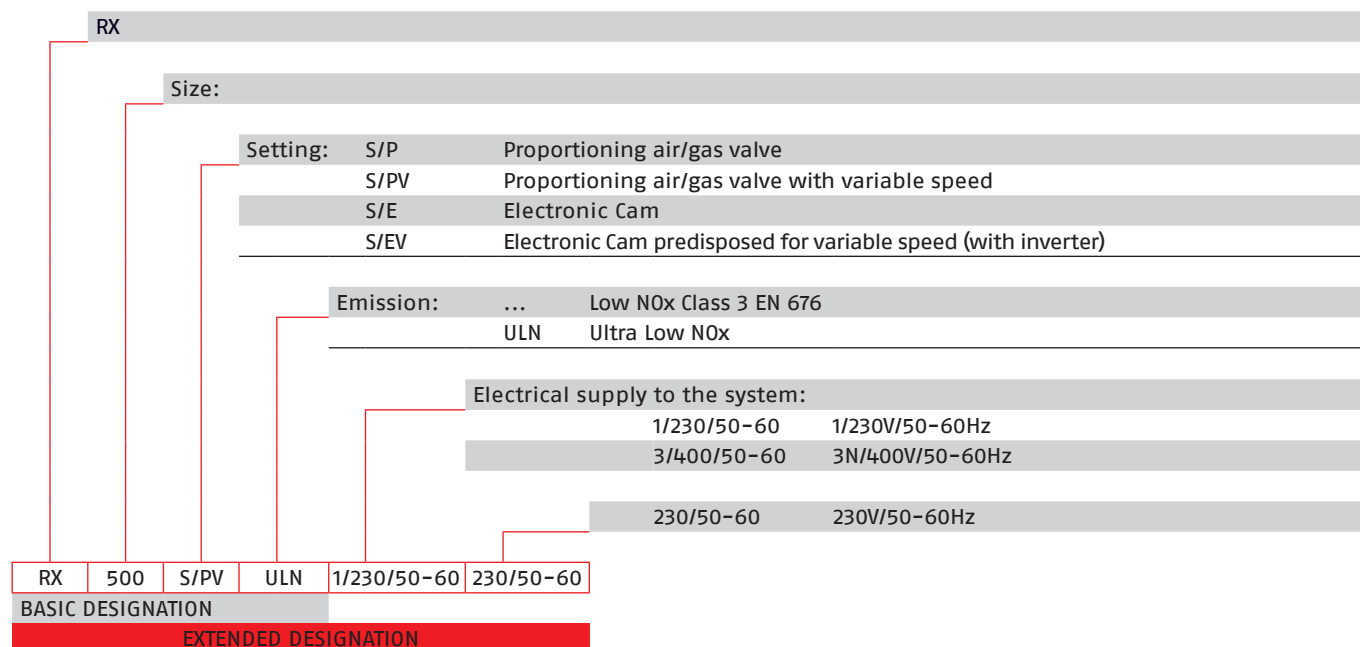

STATE OF SUPPLY

Monoblock forced draught Premix Ultra Low NOx gas burner with two stage progressive or modulating operation, with a specific kit, fully automatic, made up of:

- Cylindrical flame shape premix combustion heads fitted with:
 - highly heat resistant cylinder
 - special metallic fiber mesh resistant to thermal stress
 - ignition electrodes
 - ionization probe
- Variable speed fan with Brushless Motors
- Pneumatic proportioning gas train integrated in the burner, which supply the correct gas quantity in proportion to the airflow produced by the fan
- Air/gas mixer (venturi) in the suction line circuit to support Gas and air mixing
- Airtight ventilation structures for air and gas mixing
- Pilot Ignition system to assure a high ignition reliability
- Microprocessor-based LME 71 burner safety control box
 - manages the variable speed of the fan and all safety phases of the burner
 - allows to modify the operation point of the burner
 - with diagnostic functions for operational state and fault state messages, based on multicolor indication via 3-colored LED
- Burner on/off selection switch
- Flame inspection window
- IP 2XD electric protection level
- AZL 21 LCD display connected to the LME 71 control box to get indication of the operating status, to activate the diagnostic functions and to change the password-protected parameters

Standard equipment:

- Insulating screen and gasket
- Screws, nuts and washers for burner assembly
- Gas valve
- Flange for gas valve
- Valve fixing screws
- Electrical plugs (for model RX 180-250-360 S/PV ULN)
- Gas train for pilot ignition system
- Instruction booklet
- Spare parts list

Ultra Low NOx Modulating Premix Gas Burners

RX 180÷1000 S/PV ULN SERIES

Available models

Burners

CODE	MODEL	HEAT OUTPUT NATURAL GAS		TOTAL ELECTRICAL POWER (kW)	CERTIFICATION	NOTE
		(kW) (1)	(kW) (2)			
20160021	RX 180 S/PV ULN 1/230/50-60 230/50-60	30 - 160	30-180	0,51	CE-0085BT0104	(3)(4)(5)(6)
20160022	RX 250 S/PV ULN 1/230/50-60 230/50-60	40 - 225	40-250	0,51	CE-0085BT0104	(3)(4)(5)(6)
20148871	RX 360 S/PV ULN 1/230/50-60 230/50-60	60 - 325	60-360	0,51	CE-0085BR0225	(3)(4)(5)(6)
20148872	RX 500 S/PV ULN 1/230/50-60 230/50-60	80 - 440	80-490	1	CE-0085BR0226	(3)(4)(5)(7)
20148874	RX 700 S/PV ULN 1/230/50-60 230/50-60	140 - 630	140 - 700	1,2	CE-0085BT0516	(3)(4)(5)(7)
20148875	RX 850 S/PV ULN 1/230/50-60 230/50-60	170 - 790	170 - 880	1,2	CE-0085BT0516	(3)(4)(5)(7)
20148877	RX 1000 S/PV ULN 3/400/50-60 230/50-60	180 - 970	180-1080	2,7	CE-0085BT0516	(3)(4)(5)(7)

(1) Power range referred to an Ultra Low NOx performance of 30 mg/Nm³

(2) Power range referred to a Low NOx performance conforming to the Class 3 of EN676 European Standard

(3) The burners cannot be used on inversion flame boilers

(4) Modulation input factory setting is 3 Points; to change the external modulation parameter to analogue signal it is necessary to access the password-protected list of parameters using the AZL 21 display kit

(5) Gas train included

(6) With plug and socket

(7) With terminal board

Ultra Low NOx Modulating Premix Gas Burners

RX 180÷1000 S/PV ULN SERIES

RIELLO

Burner accessories

Accessories for modulating operation

POWER CONTROLLER



To obtain modulating operation, the RX S/PV series of burners requires a regulator with three point outlet controls. The following table lists the accessories for modulating operation with their application range.

BURNER	REGULATOR TYPE	REGULATOR CODE
▶ RX 180 S/PV ULN		
▶ RX 250 S/PV ULN	RWF 50.2 - 3-point outlet	20086840
▶ RX 360 S/PV ULN		
▶ RX 500 S/PV ULN	RWF 50.2 - 3-point outlet	20095185
▶ RX 700 S/PV ULN		
▶ RX 850 S/PV ULN	RWF 50.2 - 3-point outlet	20094733
▶ RX 1000 S/PV ULN		

PROBE



The relative temperature or pressure probes fitted to the regulator, must be chosen on the basis of the application.

BURNER	PROBE TYPE	RANGE (°C) (bar)	PROBE CODE
▶ All models	Temperature PT 100	-100 ÷ 500°C	3010110
	Pressure 4 ÷ 20 mA	0 ÷ 2,5 bar	3010213
	Pressure 4 ÷ 20 mA	0 ÷ 16 bar	3010214
	Pressure 4 ÷ 20 mA	0 ÷ 25 bar	3090873

RX 1500÷3000 S/E ULN SERIES

In order to comply the increasing demand of very low NOx emissions, Riello has developed a new product range for high power combustion, based on PREMIX low emission technology, suitable to achieve the most restrictive emission limits.

Riello RX S/E ULN Premix Range, which provides high modulation ratios and low pollution emissions, representing the ideal solution for condensing boilers and industrial processes, is based on a platform with asynchronous motors fans.

In the RX S/E ULN range, from 270 to 3210 kW, the gas is introduced downstream to the fan, so a sealed ventilation structure is not necessary because the gas and air mixture does not take place inside the aspiration circuit.

The Ultra Low NOx emission performance is achieved while maintaining high reliability of operation; on all models a high ignition reliability is assured by a Pilot Ignition system.

The burners operation is under control of a Digital Burner Management System able to manage the air-fuel ratio by independent servomotors in order to obtain a perfect output control and to assure a correct combustion and safe operation on all modulation range.



RX 1500 S/E ULN	270	÷	1650	kW
RX 1800 S/E ULN	300	÷	1940	kW
RX 2500 S/E ULN	375	÷	2485	kW
RX 3000 S/E ULN	640	÷	3210	kW

Ultra Low NOx Modulating Premix Gas Burners

RX 1500÷3000 S/E ULN SERIES

FIRING RATES

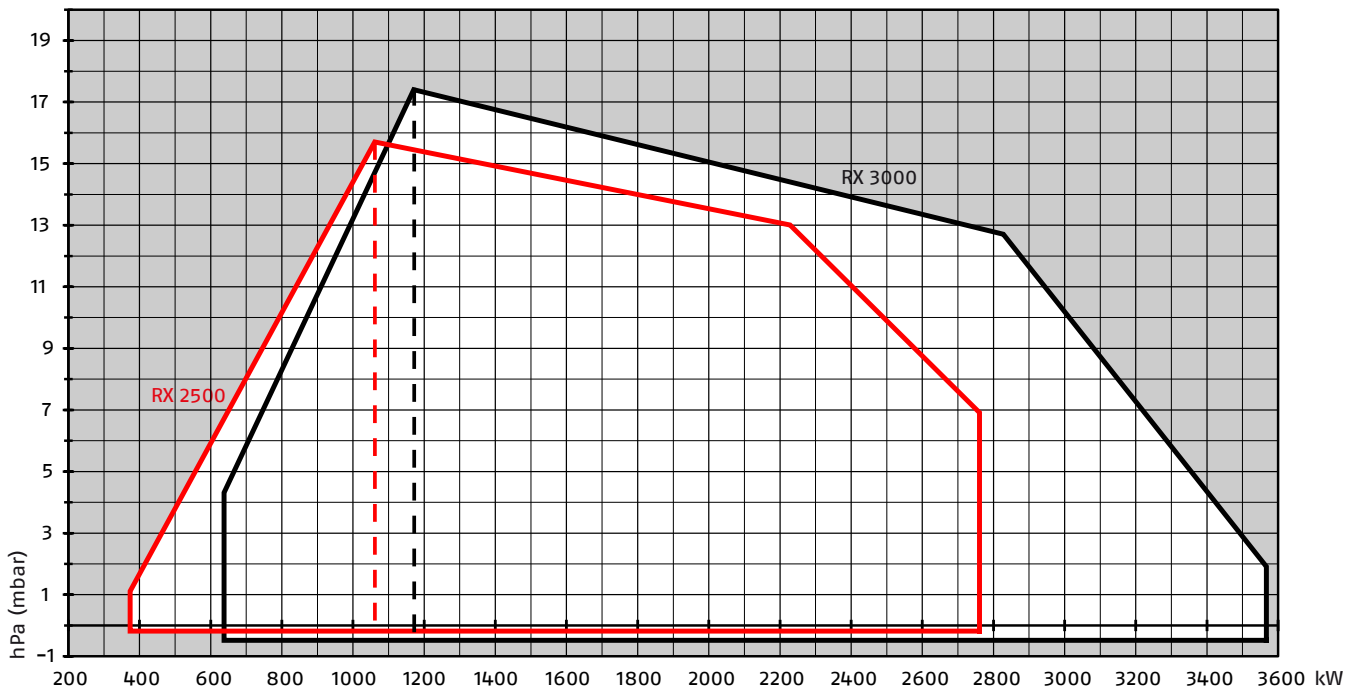
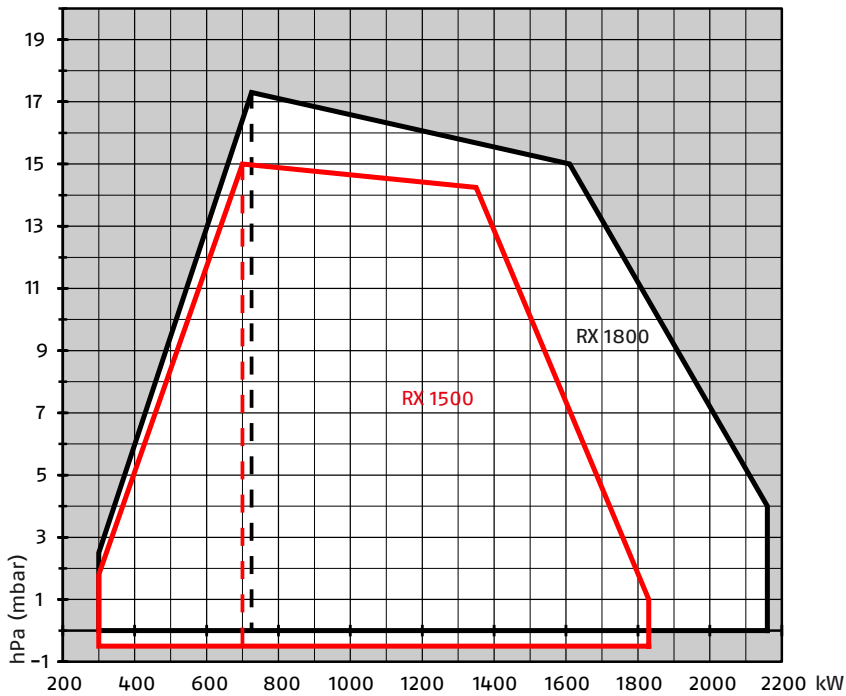

Please note: it is important to be aware that in order to achieve an ULTRA low NOx emission performance, it is required to work with a high excess air; as consequence the combustion chamber back pressure could increase up to roughly 30% more.

RX 1500÷3000 S/E ULN SERIES

Overall dimensions (mm)

BURNER

RX 1500 S/E ULN

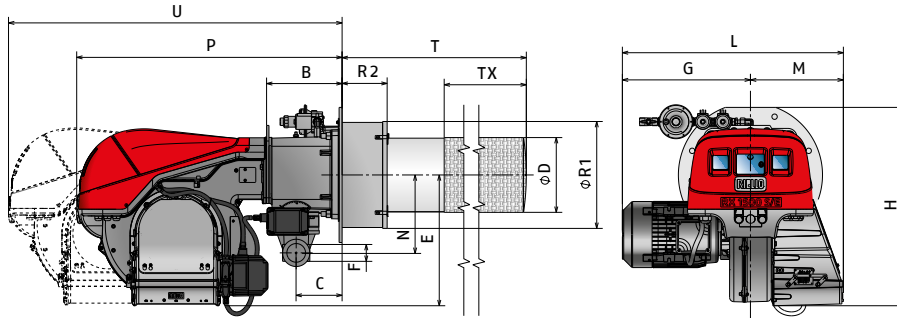

RX 1800-2500-3000 S/E ULN

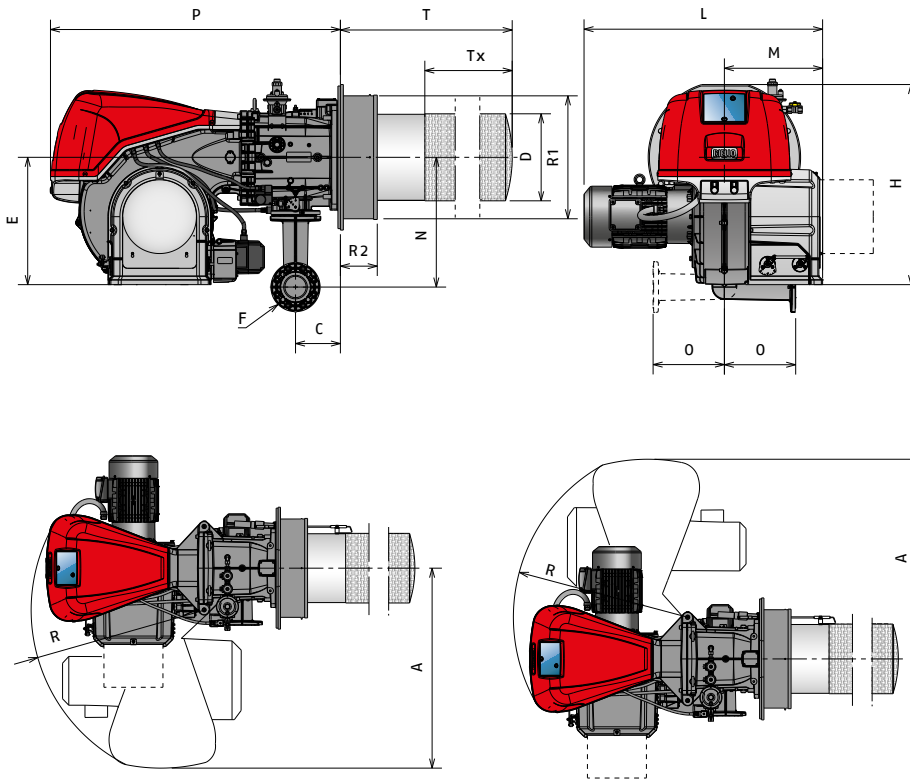

MODEL	A	B	C	D	E	F	G	H	L	M	N	O	P	T	TX	U	R	R1	R2
▶ RX 1500 S/E ULN	-	250	154	250	440	2"	426	660	734	308	260	-	885	950	590	1060	-	360	150
▶ RX 1800 S/E ULN	1015	352	178	250	520	DN65*	-	790	830	606	400	290	1178	1080	720	-	890	506	150
▶ RX 2500 S/E ULN	1015	344	178	354	520	DN65*	-	790	878	400	400	290	1178	1200	840	-	890	506	150
▶ RX 3000 S/E ULN	1015	344	178	354	520	DN65*	-	790	970	606	400	290	1178	1530	1170	-	890	506	150

TX: flame zone length; the non combustion area (T-TX) must be greater than the thickness of the boiler door complete with refractory.
 * The gas adaptor is set also for DN 80 bore.

Ultra Low NOx Modulating Premix Gas Burners

RX 1500÷3000 S/E ULN SERIES

Overall dimensions (mm)

BURNER - BOILER MOUNTING FLANGE

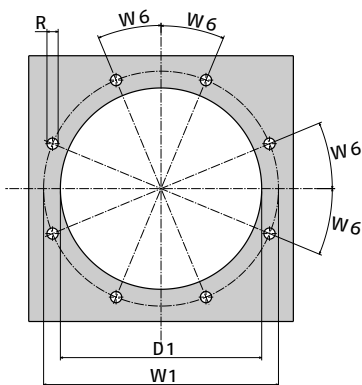

MODEL	D1	W1	R	W6
▶ RX 1500 S/E ULN	370	470	M16	22.5°
▶ RX 1800 S/E ULN	520	560	M18	22.5°
▶ RX 2500 S/E ULN	520	560	M18	22.5°
▶ RX 3000 S/E ULN	520	560	M18	22.5°

PACKAGING

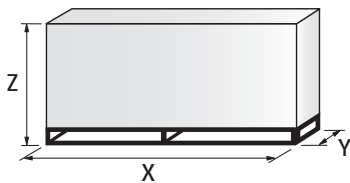

BURNER MODEL	X	Y	Z	kg
▶ RX 1500 S/E ULN	2510	1070	1300	130
▶ RX 1800 S/E ULN	1650	1260	950	200
▶ RX 2500 S/E ULN	1650	1260	950	220
▶ RX 3000 S/E ULN	1650	1260	950	220

COMB. HEAD MODEL	X	Y	Z	kg
▶ RX 1500 S/E ULN	Included in the burner box			
▶ RX 1800 S/E ULN	1310	650	800	80
▶ RX 2500 S/E ULN	1700	650	800	80
▶ RX 3000 S/E ULN	1700	650	800	100

RX 1500÷3000 S/E ULN SERIES

Specification

DESIGNATION OF SERIES

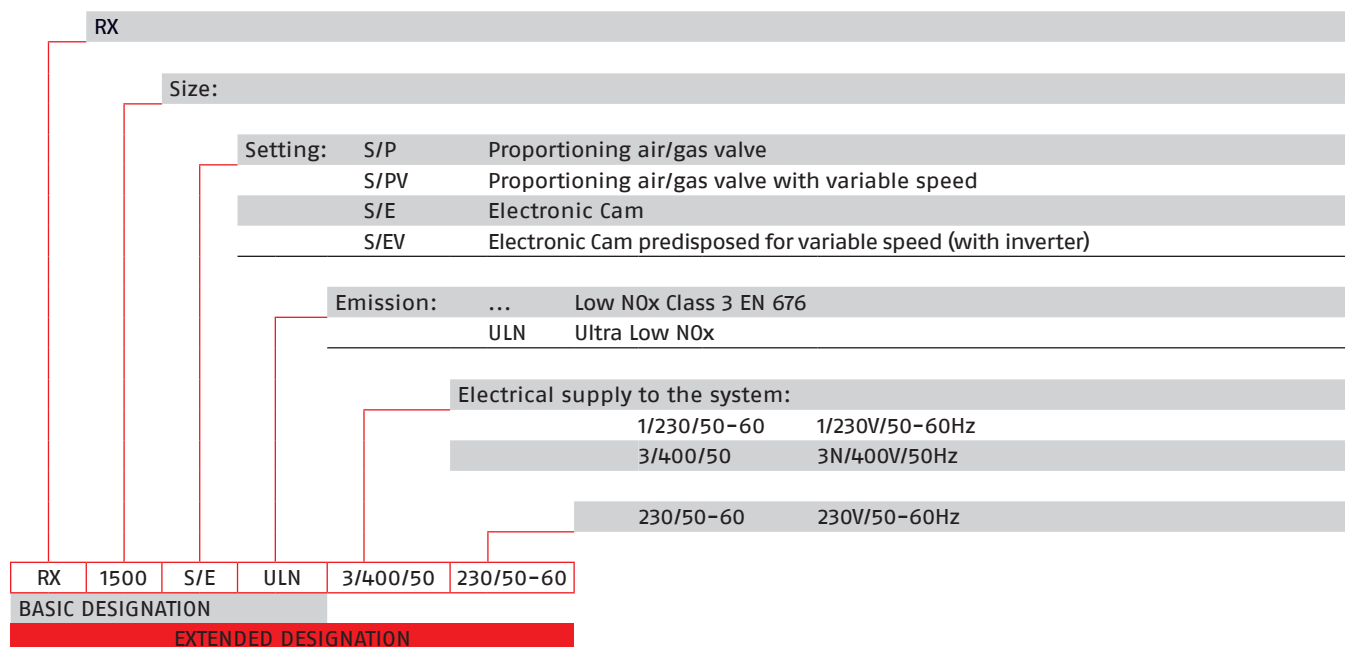

STATE OF SUPPLY

Monoblock forced draught Premix Ultra Low NOx gas burner with two stage progressive or modulating operation, with a specific kit, fully automatic, made up of:

- Cylindrical flame shape premix combustion heads fitted with:
 - highly heat resistant cylinder
 - special metallic fiber mesh resistant to thermal stress
 - ignition electrodes
- Double combustion control devices, made up of
 - temperature probe which controls the temperature inside the combustion head to prevent damage to the combustion head
 - UV flame sensor
- Pilot Ignition system to assure a high ignition reliability
- Microprocessor-based Digital Burner Management System
 - manages all the safety phases of the burner
 - allows to modify the operation point of the burner
 - with diagnostic functions for operational status and fault messages
- AZL display Interface, operating unit to adjust the system
- Fan with asynchronous motor
- Air suction circuit lined with sound-proofing material
- Air damper for air flow setting and butterfly valve for regulating fuel output controlled by independent stepper motor actuators
- Burner on/off selection switch
- Low gas pressure switch to cause controlled safety shut-down when the supply pressure falls below a pre-determined value
- Maximum gas pressure switch to stop the burner in the case of excess pressure on the fuel supply line
- Minimum air pressure switch stops the burner in case of insufficient air quantity at the combustion head
- No. 2 air pressure switches, light indicators, relays and fuses that set up the air intake filter (air filter is an accessory to be ordered separately)
- Relays with clean contacts for signaling the burner is operating or the burner's lock-out
- Fixing flange with insulating panel
- Flame inspection window
- Slide bars (RX 1500) or Hinge opening (RX 1800-2500-3000) for easier installation and maintenance
- Electric protection level IP44 RX 1500 – IP 54 RX 1800-2500-3000

Standard equipment:

- Insulating screen
- Gas train adapter
- Gas train for pilot ignition system for RX 1500 (installed on burner for RX 1800-2500-3000)
- Instruction booklet
- Spare parts list

Ultra Low NOx Modulating Premix Gas Burners

RX 1500÷3000 S/E ULN SERIES

Available models

Burners

CODE	MODEL	COMBUSTION HEAD CODE (1)	HEAT OUTPUT NATURAL GAS		TOTAL ELECTRICAL POWER (kW)	CERTIFICATION	NOTE
			(kW) (2)	(kW) (3)			
20148878	RX 1500 S/E ULN 3/400/50 230/50-60	INCLUDED	270 - 1650	270 - 1830	6,65	CE-0085CT0448	(4)(5)(6)(7)(8)(9)
20148880	RX 1800 S/E ULN 3/400/50 230/50-60	20151520	300 - 1940	300 - 2155	5,56	CE-0085CT0448	(4)(5)(6)(7)(8)(9)
20148881	RX 2500 S/E ULN 3/400/50 230/50-60	20151274	375 - 2485	375 - 2765	6,65	CE-0085CT0448	(4)(5)(6)(7)(8)(9)
20148882	RX 3000 S/E ULN 3/400/50 230/50-60	20151483	640 - 3210	640 - 3560	8,50	CE-0085CT0448	(4)(5)(6)(7)(8)(9)

(1) For models RX 1800-2500-3000 S/E ULN, the combustion head is supplied separated from the burner and must be ordered with the specific code

(2) Power range referred to an Ultra Low NOx performance of 30 mg/Nm³

(3) Power range referred to a Low NOx performance conforming to the Class 3 of EN676 European Standard

(4) according to 2016/426/EU - 2014/35/EU - 2014/30/EU - 2006/42 EC Directive.

(5) Gas train must be ordered separately (please see Gas Trains paragraph)

(6) Seal control function is included on Burner Digital Management System, by connection to the dedicated pressure switch included as standard equipment on the gas train

(7) Direct starter fan motor

(8) Electrical connections with terminal board

(9) The burners cannot be used on inversion flame boilers

Gas Trains

BURNER MODEL	CODE	GAS TRAIN MODEL	Ø	ADAPTER	NOTE
RX 1500 S/E ULN	20129303	VGD 50/1	2"	(1)	(2)
RX 1800 S/E ULN					
RX 2500 S/E ULN	20126626	VGD 65/1	DN65	(1)	(2)
RX 3000 S/E ULN					

(1) The Burner/Gas Train adapter is included on burner as standard equipment

(2) The Gas train includes a gas pressure switch to be connected to the Burner's Digital Management System, to allow the seal control function

Ultra Low NOx Modulating Premix Gas Burners

RX 1500÷3000 S/E ULN SERIES

RIELLO

Burner accessories

Accessories for modulating operation

POWER CONTROLLER



To obtain modulating operation, the RX S/E series of burners requires a regulator with three point outlet controls. The following table lists the accessories for modulating operation with their application range. For remote setpoint use RWF 55.

BURNER	REGULATOR TYPE	REGULATOR CODE
▶ RX 1500 S/E ULN	RWF 50.2 - 3-point outlet	20099869
	RWF 55.5 - complete with RS-485 interface	20099905
▶ RX 1800-2500-3000 S/E ULN	RWF 50.2 - 3-point outlet	20085417
	RWF 55.5 - complete with RS-485 interface	20074441
	RWF 55.6 - complete with RS-485 profibus interface	20074442

PROBE



The relative temperature or pressure probes fitted to the regulator, must be chosen on the basis of the application.

BURNER	PROBE TYPE	RANGE (°C) (bar)	PROBE CODE
▶ All models	Temperature PT 100	-100 ÷ 500°C	3010110
	Pressure 4 ÷ 20 mA	0 ÷ 2,5 bar	3010213
	Pressure 4 ÷ 20 mA	0 ÷ 16 bar	3010214
	Pressure 4 ÷ 20 mA	0 ÷ 25 bar	3090873

PC Interface kit



To connect the control box to a personal computer for the transmission of operation, fault signals and detailed service information, an interface adapter with PC software are available.

BURNER	KIT CODE
▶ All models	3010436

OCI412 interface kit



Interface kit between the REC27.100A2 and a Modbus system, such as a building automation and control system (BACS). The Modbus interface is based on the RS-485 standard.

BURNER	KIT CODE (1)
▶ RX 1800-2500-3000 S/E ULN	3010437

(1) Not applicable on RX 1500 S/E ULN

ULTRA LOW NOx
GAS

Ultra Low NOx Modulating Premix Gas Burners

RX 1500÷3000 S/E ULN SERIES

Burner accessories

Air filter

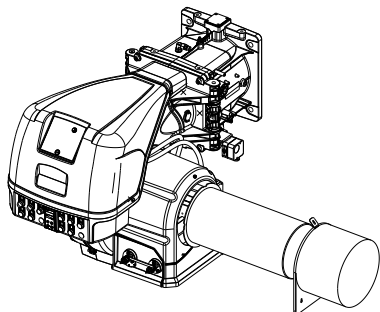

When burner is used in dusty environment, in order to prevent the possible ingress of foreign elements in the air circuit, a filter is available as accessory to be installed in the air intake side of the burner.

Because the RIELLO combustion head is made by mesh, and not fiber, the grade of filtration can be lower, allowing to lengthen filter cleaning time, so reducing cost and to fully exploit the potential of the ventilating structure, assuring in the meantime a correct combustion.

The Air Filter specifically studied for RIELLO RX S/E ULN burners is easily cleanable with compressed air in order to avoid the need to change it each time the maintenance is required.

The use of Air Filter involves a working field reduction, please refer to the instruction manual for detailed info.

BURNER	KIT CODE
▶ RX 1500 S/E ULN	20164652
▶ RX 1800-2500 S/E ULN	20156978
▶ RX 3000 S/E ULN	20141720

Continuous ventilation kit



If the burner requires continuous ventilation in the stages without flame, a special kit is available as given in the following table.

BURNER	KIT CODE
▶ RX 1500 S/E ULN	3010094
▶ RX 1800-2500-3000 S/E ULN	20074542

RS 68÷2000/E FGR SERIES

Due to the significant increase of pollutants in these last years, attention to performance, energy efficiency and emission reduction is becoming more important all around the world, in particular in all the highly industrialized countries.

In order to comply the increasing demand of very low NOx emissions, Riello has developed a new range of Monoblock burners, based on FGR (Flue gas Recirculation) low emission technology, suitable to achieve the most restrictive emission limits.

FGR technology is based on the recirculation of a part of the exhaust gas, which is introduced in the air inlet side of the burner; an integrated Digital Burner Management System, through the action of independent servomotors, allows the control of air, fuel and exhaust gas proportion in every working point, in order to reach very low NOx emissions, while maintaining high reliability of operation.

On all models a high ignition reliability is assured by a Pilot Ignition system.

All the components are integrated in a compact size, in order to facilitate and make extremely easy the installation and maintenance.



RS 68/E FGR	195	÷	350/810	kW
RS 120/E FGR	300	÷	595/1150	kW
RS 160/E FGR	350	÷	958/1849	kW
RS 200/E FGR	550	÷	1372/2300	kW
RS 310/E FGR	400	÷	1200/3630	kW
RS 410/E-/EV FGR	595	÷	1210/3820	kW
RS 510/E-/EV FGR	660	÷	1800/4800	kW
RS 610/E-/EV FGR	912	÷	2200/5850	kW
RS 810/E FGR	1100	÷	3500/6990	kW
RS 1000/E FGR	1100	÷	4000/10100	kW
RS 1200/E FGR	1500	÷	5500/11100	kW
RS 1300/E FGR	2500	÷	7500/13000	kW
RS 1600/E FGR	3065	÷	9503/15560	kW
RS 2000/E FGR	4000	÷	12000/19500	kW

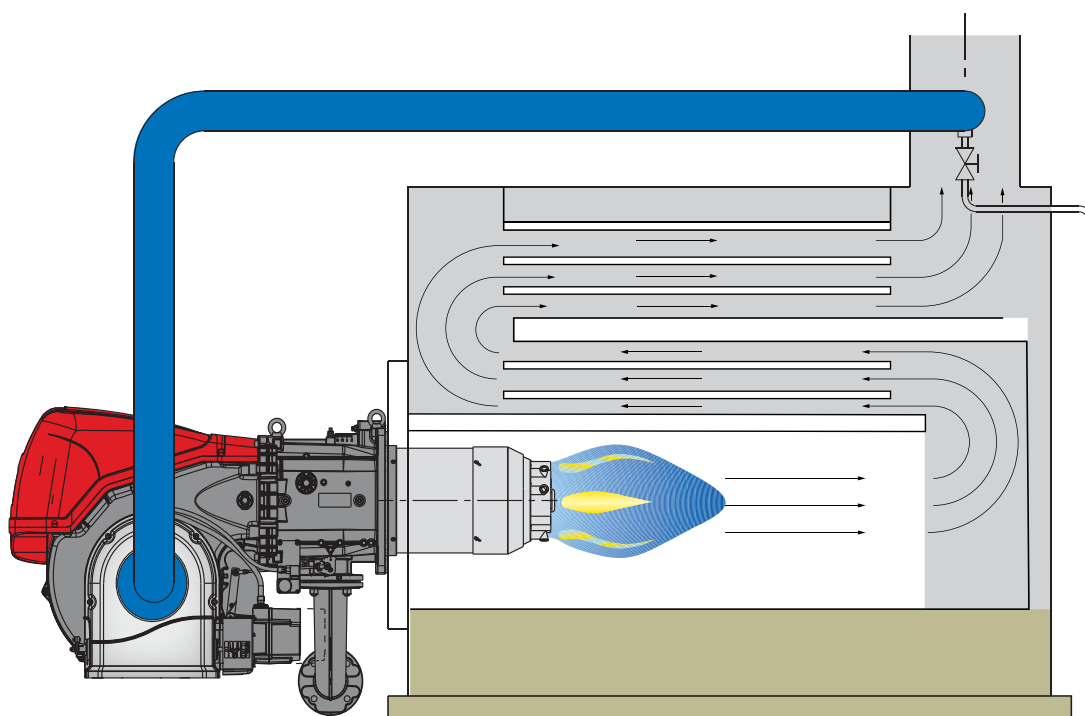

Ultra Low NO_x Gas FGR Burners

RS 68÷2000/E FGR SERIES

FIRING RATES

Please note: it is important to be aware that the use of the Flue Gas Recirculation (FGR) function, in order to achieve an ULTRA Low NO_x emission performance, might lower the burner's maximum output, because the maximum amount of combustion air that can be introduced will be reduced, and so the oxygen concentration.

The shown firing rates are obtained in special test boilers, according to EN 676 regulation and referred to a Low NO_x performance conforming to the Class 3 of EN676, with 0% of Flue Gas Recirculation; by increasing the recirculation % in order to achieve an ULTRA Low NO_x emission the burner's maximum output will be reduced.

A Flue Gas Recirculation % needed to obtain an Ultra Low NO_x performance of 30 mg/Nm³ will involve a maximum output reduction of at list 20%.

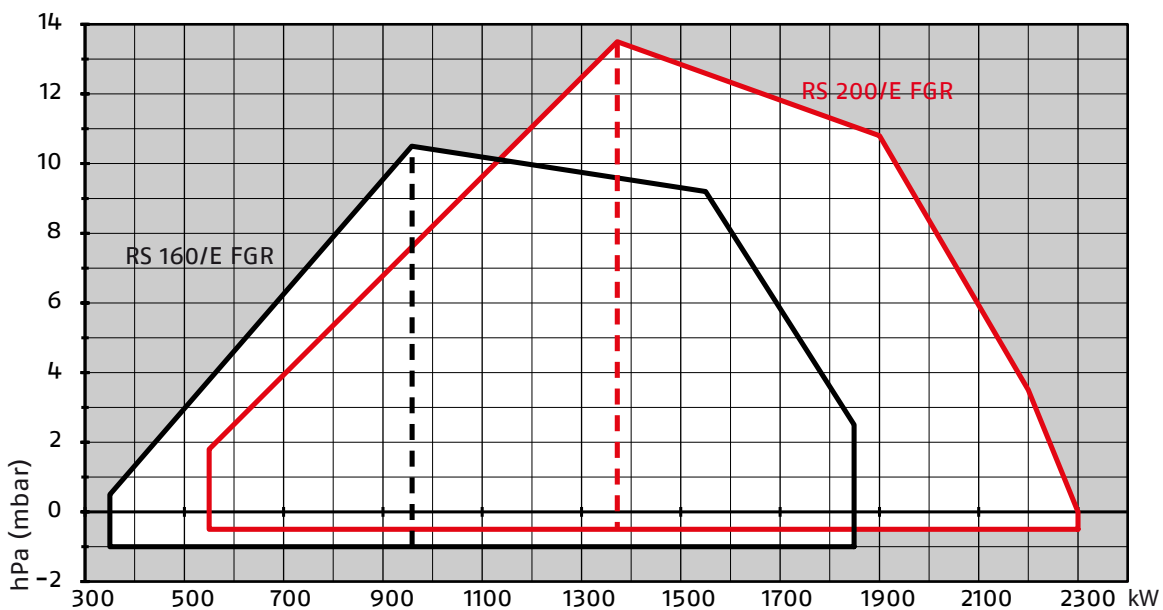
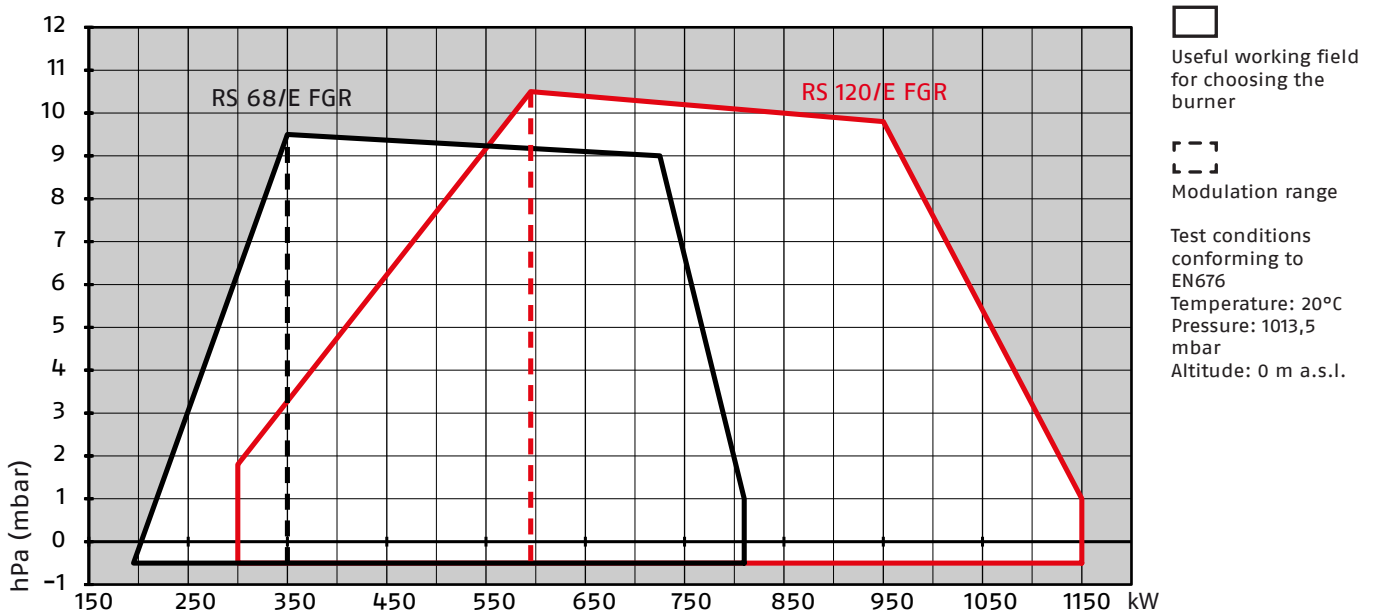

Ultra Low NOx Gas FGR Burners

RS 68÷2000/E FGR SERIES

RIELLO

FIRING RATES

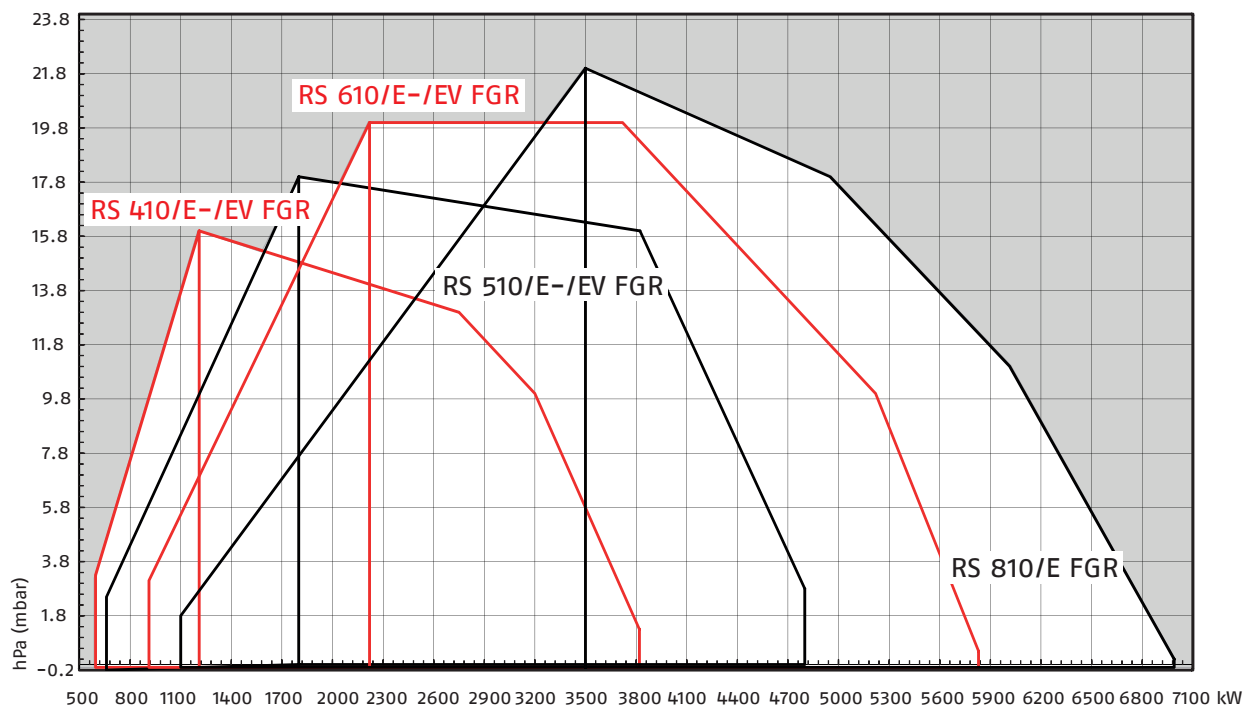
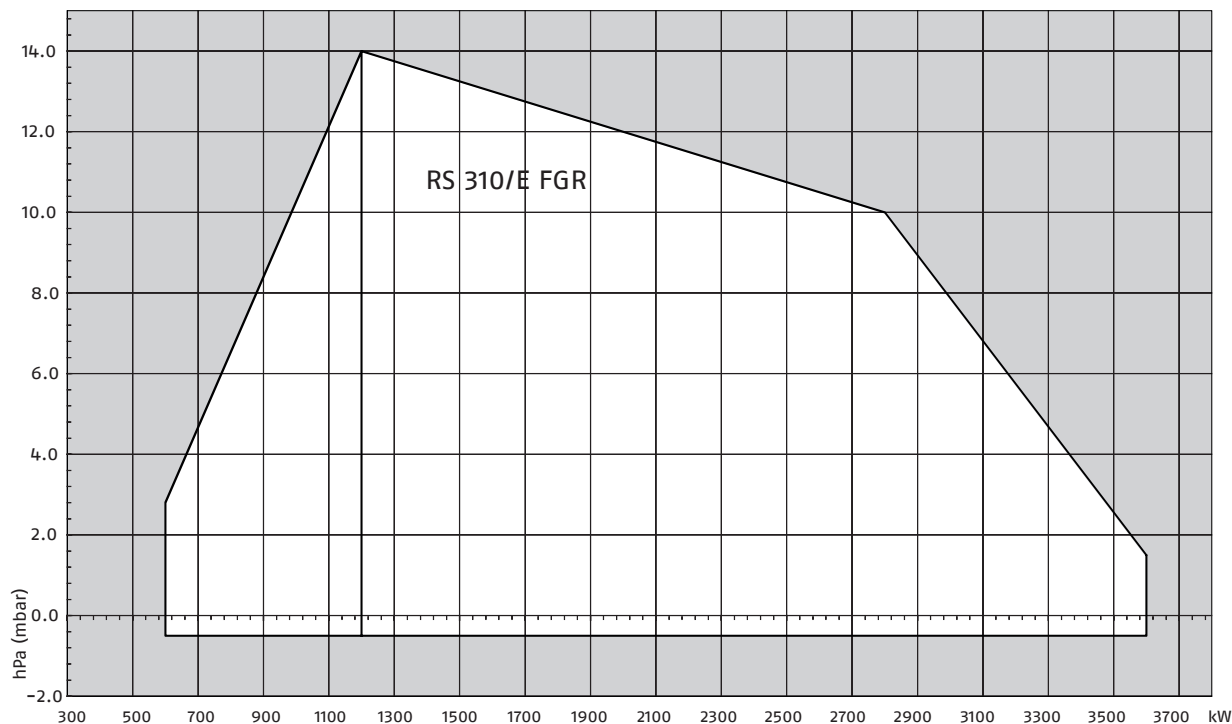

Test conditions
conforming to EN676
Temperature: 20°C
Pressure: 1013,5 mbar
Altitude: 0 m a.s.l.

ULTRA LOW NOx
GAS

Ultra Low NOx Gas FGR Burners

RS 68÷2000/E FGR SERIES

FIRING RATES

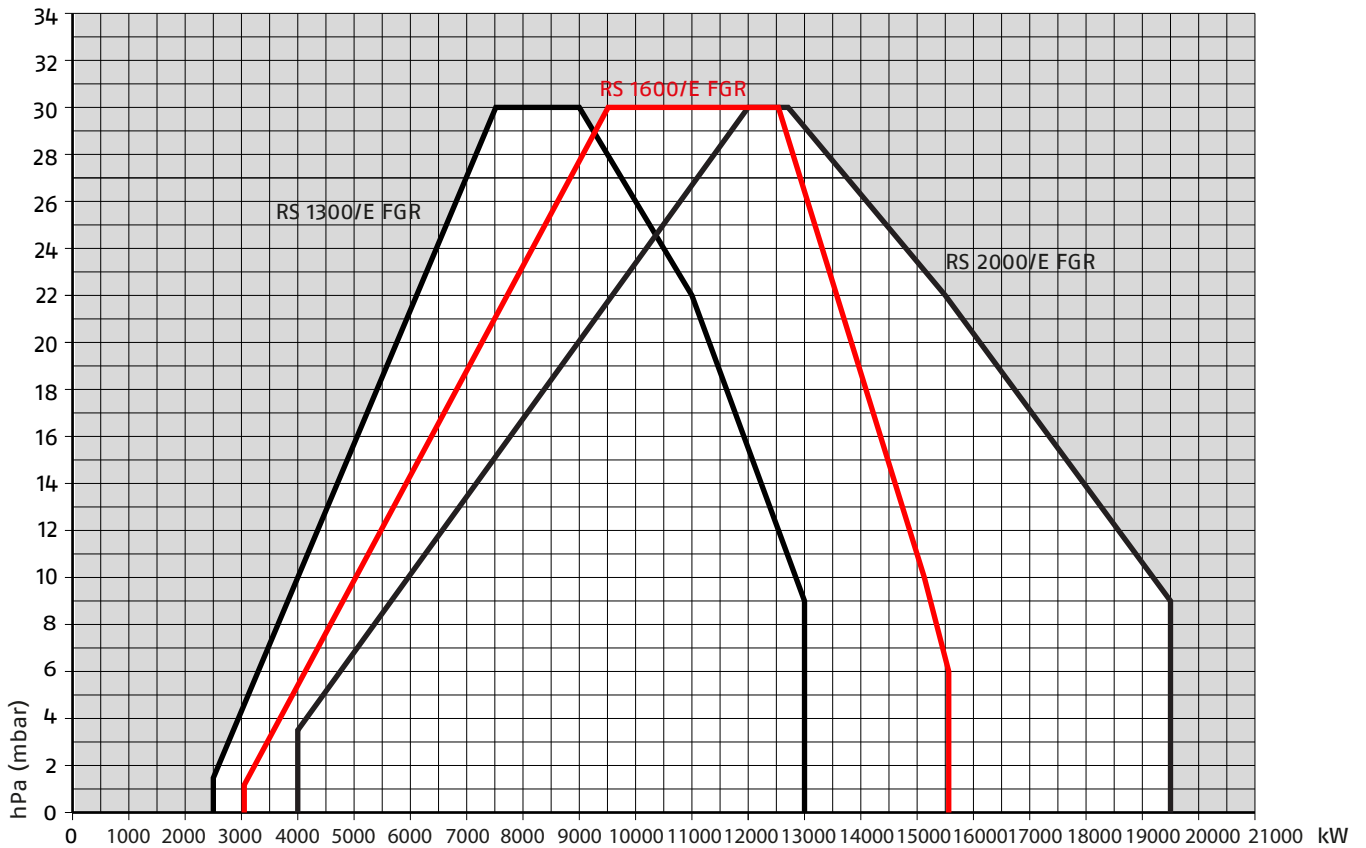
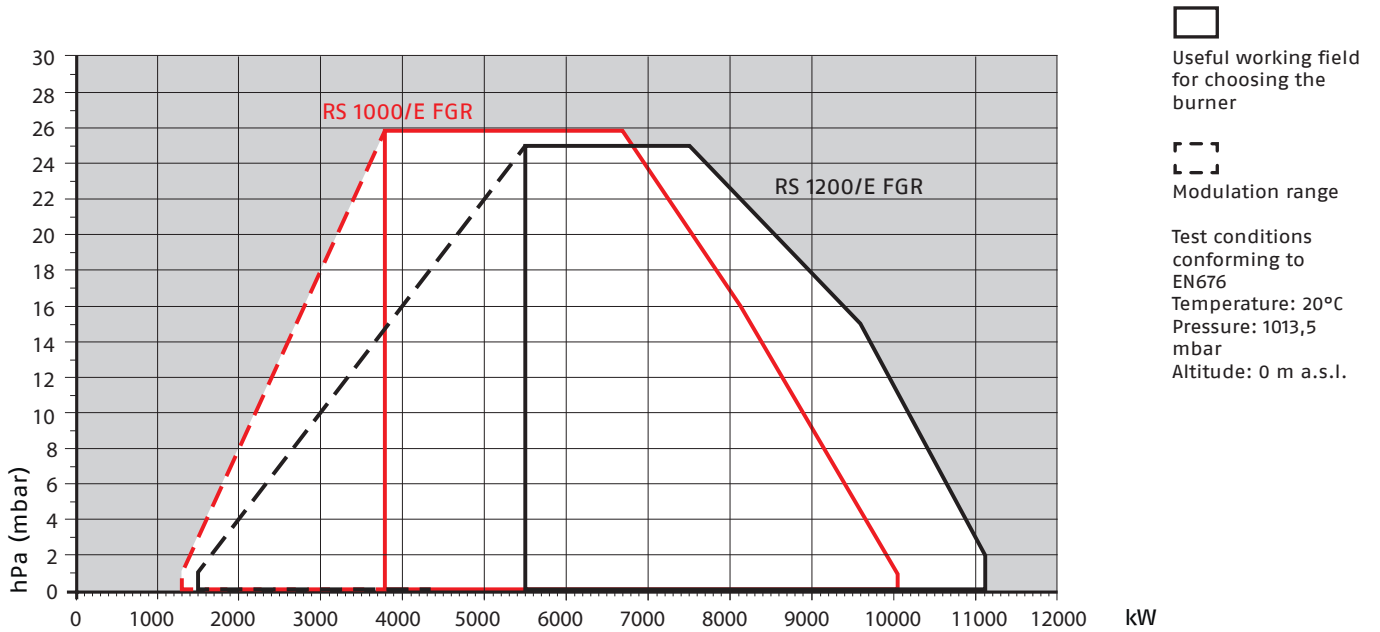

Overall dimensions (mm)

BURNER

RS 68-120/E FGR

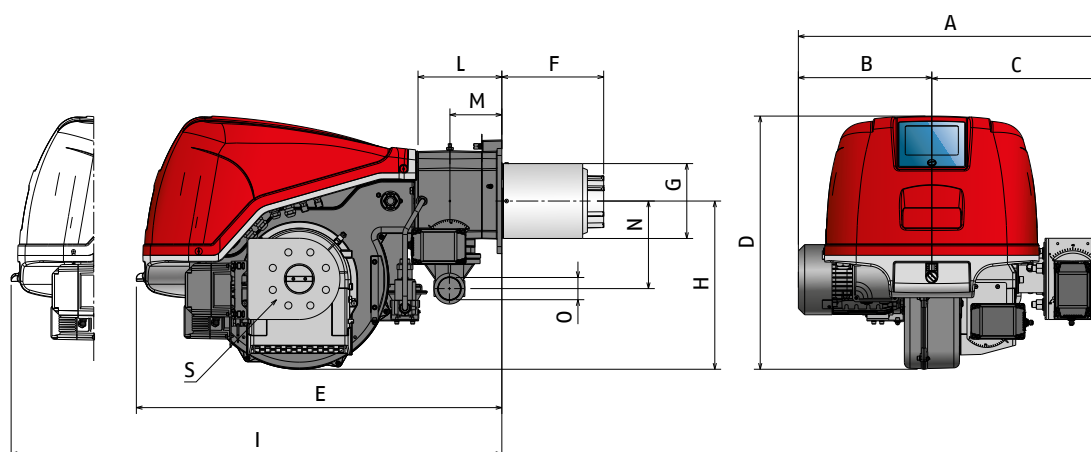

RS 160-200/E FGR

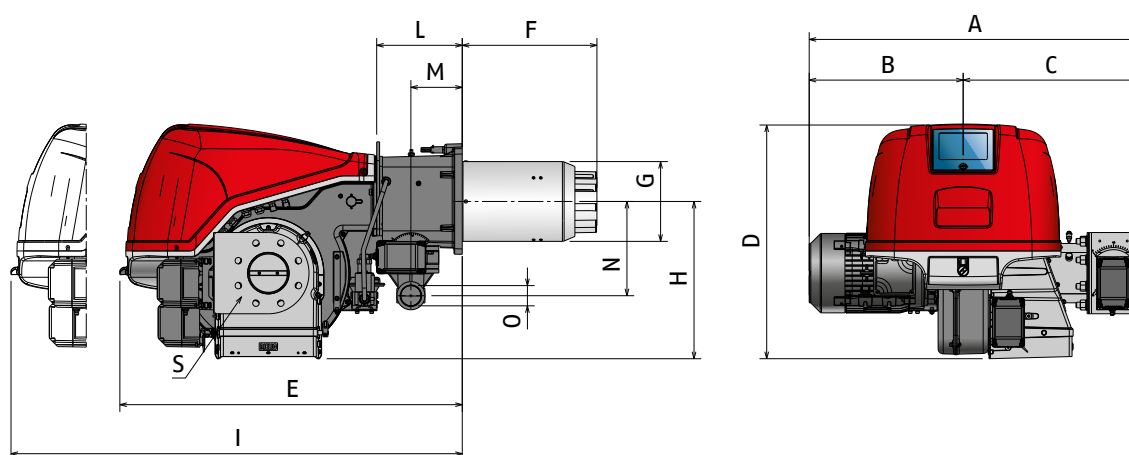

MODEL	A	B	C	D	E	F-F (1)	G	H	I (1)	L	M	N	O	S
▶ RS 68/E FGR	738	312	426	640	922	255-390	189	425	1393-1528	214	134	221	2"	DN65
▶ RS 120/E FGR	763	337	426	640	922	255-390	189	425	1393-1528	214	134	221	2"	DN65
▶ RS 160/E FGR	764	378	486	650	950	373-503	222	435	1520-1665	237	141	260	2"	DN80
▶ RS 200/E FGR	913	427	486	650	950	373-503	222	435	1520-1665	237	141	260	2"	DN100

(1) Dimension with extended head

Ultra Low NOx Gas FGR Burners

RS 68÷2000/E FGR SERIES

Overall dimensions (mm)

BURNER

RS 310-610/E FGR

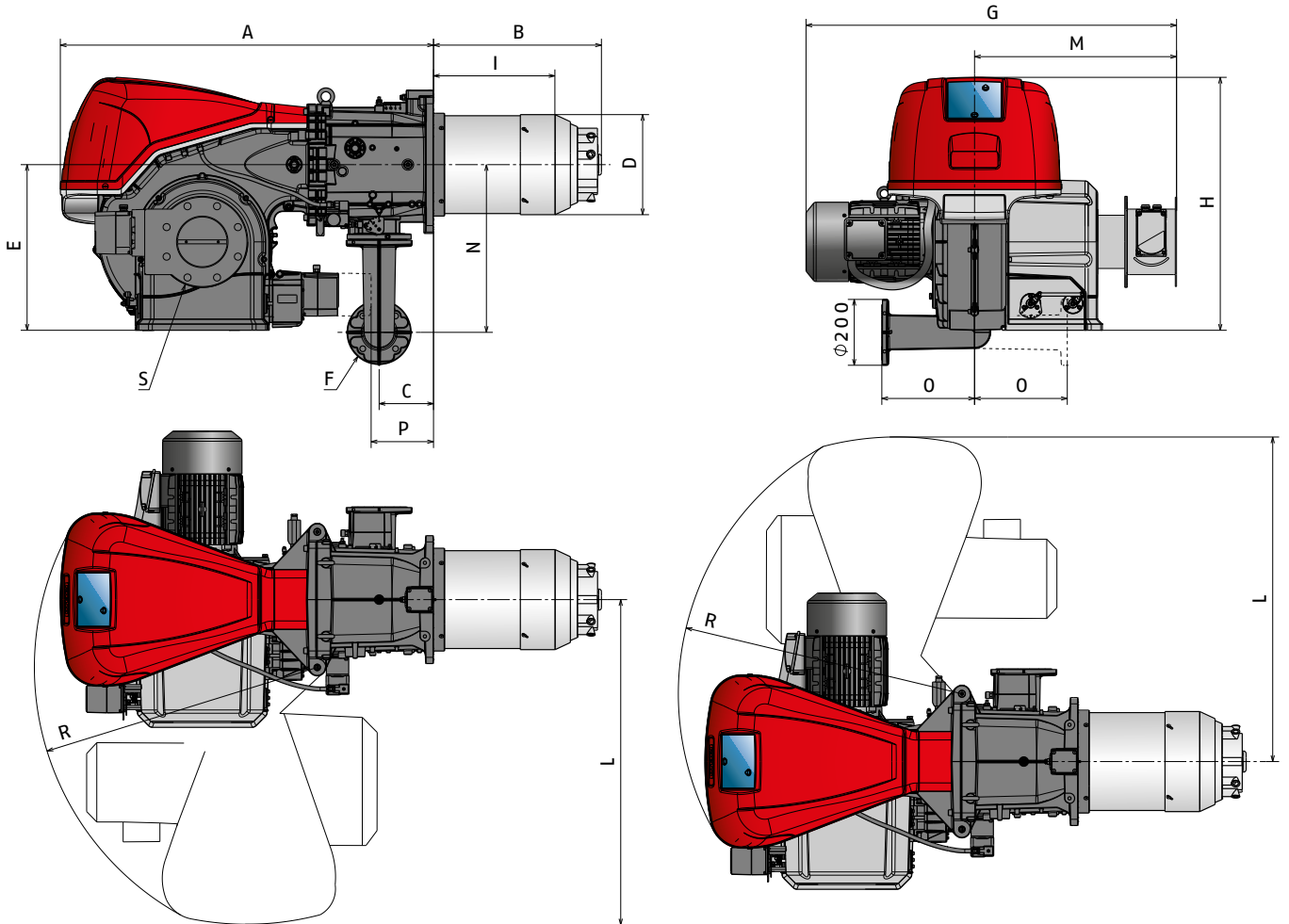

MODEL	A	B	C	D	E	F*	G	H	I	L	M	N	O	P**	R	S
▶ RS 310/E FGR	1178	465	178	306	520	DN65	1185	790	346	1015	615	528	290	177	890	DN100
▶ RS 410/E FGR	1178	517	178	313	520	DN65	1140	790	340	1015	615	528	290	177	890	DN100
▶ RS 510/E FGR	1260	517	178	313	520	DN65	1140	790	360	1015	620	528	290	177	890	DN125
▶ RS 610/E FGR	1260	517	178	336	520	DN65	1215	790	365	1015	632	528	290	177	890	DN150

* The gas adaptor is set also for DN 80 bore.

** Maximum position for the extraction of the servomotor cover.

Overall dimensions (mm)

BURNER

RS 810/E FGR

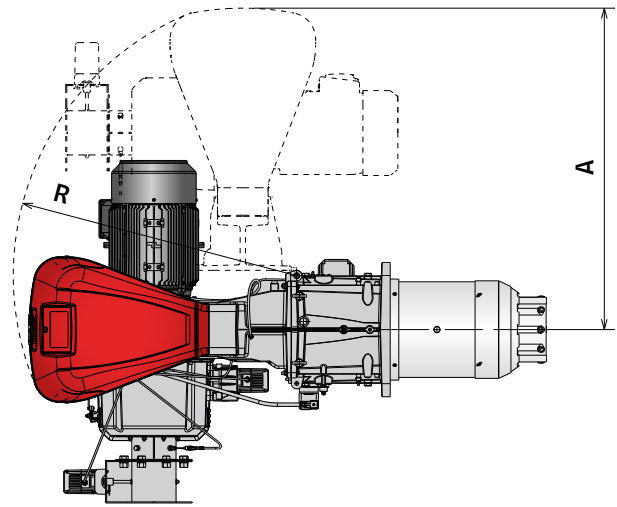
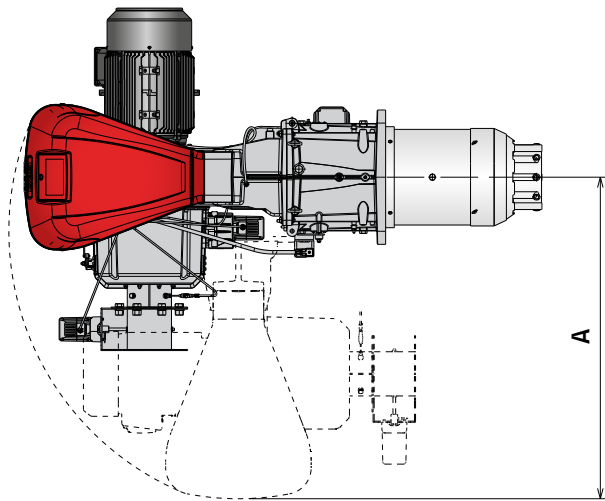
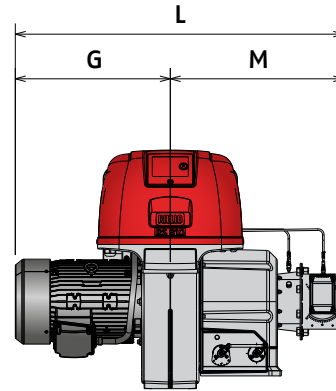
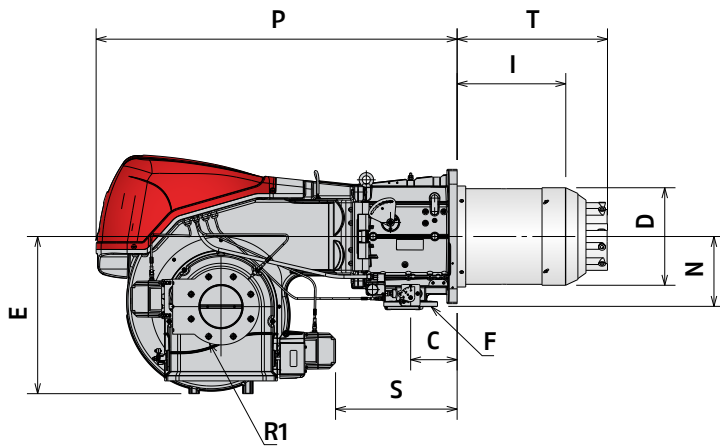

MODEL	A	C	D	E	F	G	I	L	M	N	P	R	R1	S	T
► RS 810/E FGR	1197	173	363	585	DN80	577	405	1222	645	260	1345	1055	6" - DN 150	450	558

Ultra Low NOx Gas FGR Burners

RS 68÷2000/E FGR SERIES

Overall dimensions (mm)

BURNER

RS 1000-1200/E FGR

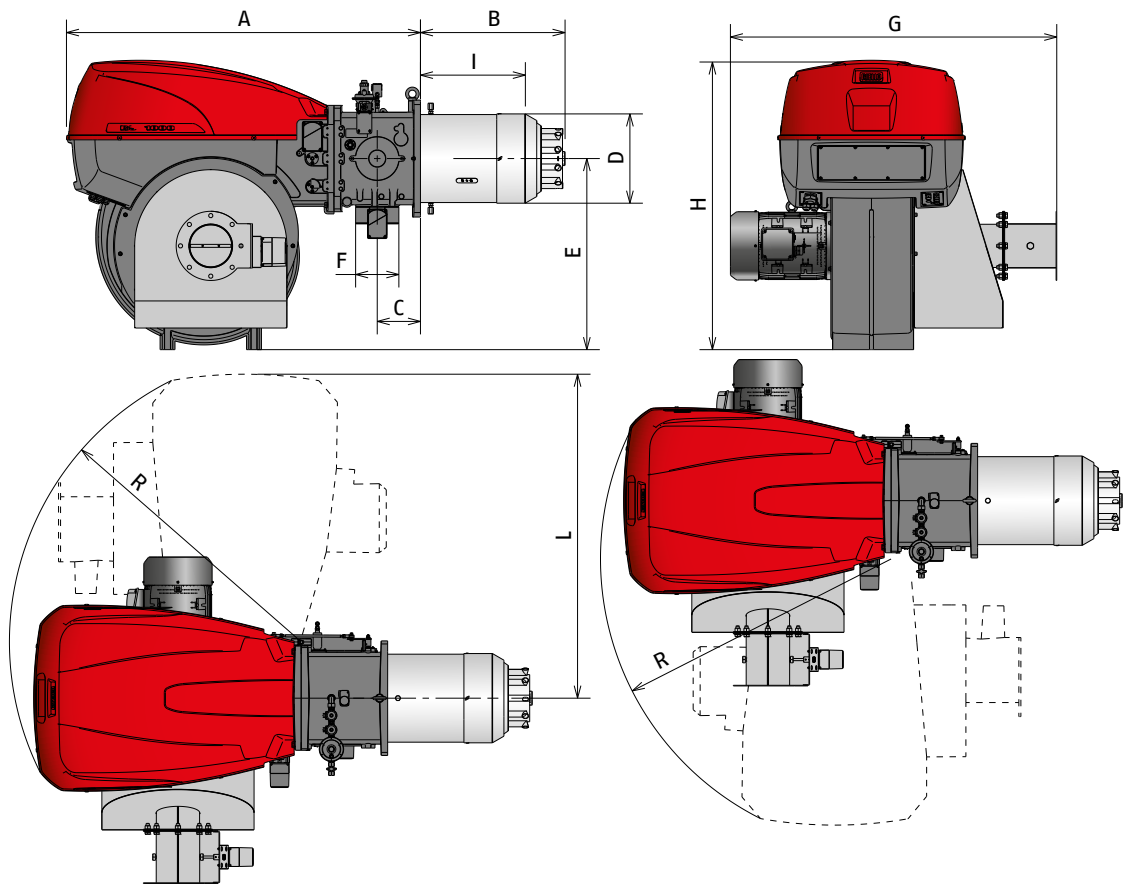

MODEL	A	B	C	D	E	F	G	H	I	L	R
▶ RS 1000/E FGR	1637	669	200	413	885	DN80	1510	1338	485	1493	1350
▶ RS 1200/E FGR	1637	670	200	456	885	DN80	1630	1338	463	1493	1350

Overall dimensions (mm)

BURNER

RS 1300-1600-2000/E FGR

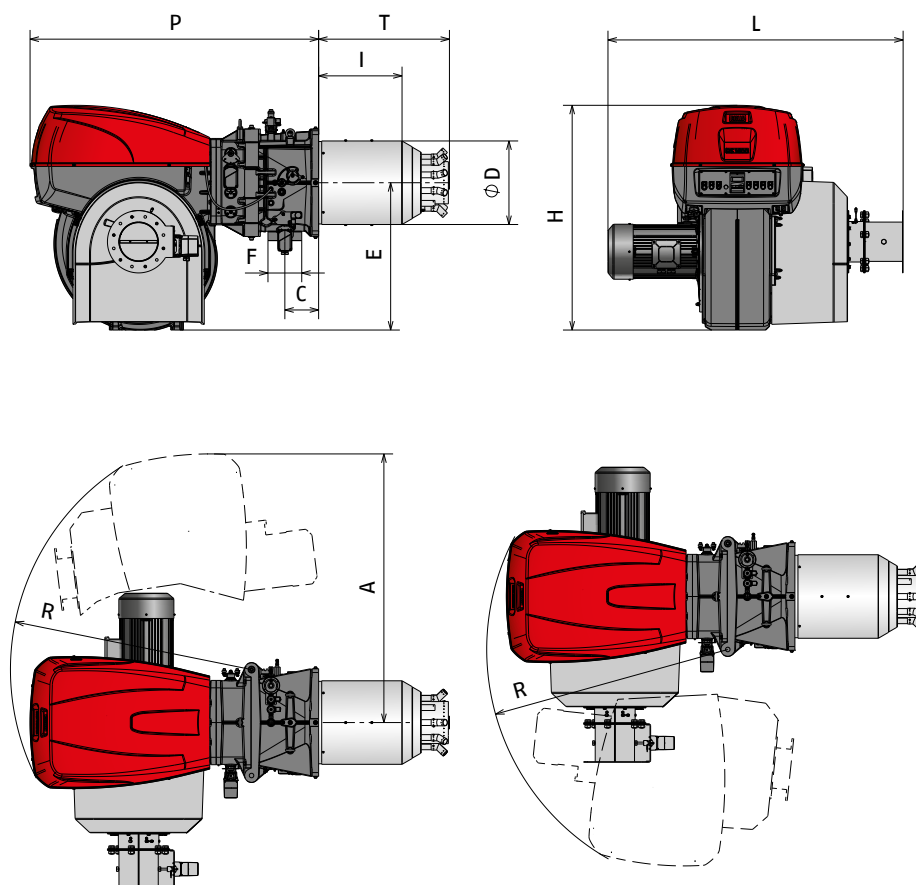

MODEL	A	C	D	E	F	H	I	L	P	R	T
▶ RS 1300/E FGR	1782	220	544	960	DN80	1463	383	1928	1880	1565	613
▶ RS 1600/E FGR	1785	220	544	960	DN100	1463	544	1922	1880	1565	852
▶ RS 2000/E FGR	1782	220	590	960	DN100	1463	562	1922	1880	1565	852

Ultra Low NOx Gas FGR Burners

RS 68÷2000/E FGR SERIES

Overall dimensions (mm)

BURNER - BOILER MOUNTING FLANGE

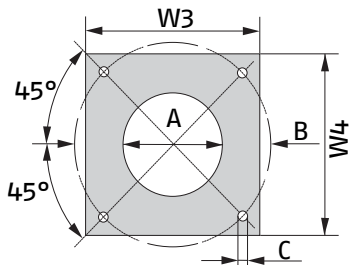

MODEL	A	B	C
▶ RS 68/E FGR	195	275 - 325	M12
▶ RS 120/E FGR	195	275 - 325	M12
▶ RS 160/E FGR	230	325 - 368	M16
▶ RS 200/E FGR	230	325 - 368	M16
▶ RS 310/E FGR	335	452	M18
▶ RS 410/E FGR	335	452	M18
▶ RS 510/E FGR	335	452	M18
▶ RS 610/E FGR	350	452	M18
▶ RS 810/E FGR	400	495	M18
▶ RS 1000/E FGR	460	608	M20
▶ RS 1200/E FGR	500	608	M20

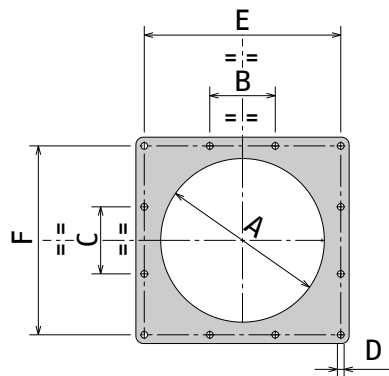

MODEL	A	B	C	D	E	F
▶ RS 1300/E FGR	580	215	220	M20	645	620
▶ RS 1600/E FGR	580	215	220	M20	645	620
▶ RS 2000/E FGR	580	215	220	M20	645	620

PACKAGING

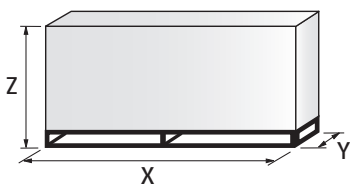

MODEL	X	Y	Z	kg
▶ RS 68/E FGR	1500	850	1000	100
▶ RS 120/E FGR	1500	850	1000	105
▶ RS 160/E FGR	1500	850	1000	110
▶ RS 200/E FGR	1500	850	1000	148
▶ RS 310/E FGR	2040	1280	1125	265
▶ RS 410/E FGR	2040	1280	1125	265
▶ RS 510/E FGR	2040	1280	1125	265
▶ RS 610/E FGR	2040	1280	1125	295
▶ RS 810/E FGR	2150	1070	1425	320
▶ RS 1000/E FGR	2640	1700	1750	450
▶ RS 1200/E FGR	2640	1700	1750	470
▶ RS 1300/E FGR	2960	1750	1800	1180
▶ RS 1600/E FGR	2960	1750	1800	1180
▶ RS 2000/E FGR	2960	1750	1800	1220

Ultra Low NOx Gas FGR Burners

RS 68÷2000/E FGR SERIES

RIELLO

Specification

DESIGNATION OF SERIES

Series: R

Fuel: S Natural Gas
 L Light oil
 LS Light oil/Natural Gas
 N Heavy oil

Size:

Setting: /1 Single stage
 /B Two stage
 /M Modulating-Mechanical cam
 /E Electronic cam
 /P Proportioning air/gas valve
 /EV Electronic cam predisposed for variable speed (with inverter)
 /EVi Electronic cam with integrated inverter

Emission: ... or CO1 Class 1 EN676
 MZ Class 2 EN676
 BLU Class 3 EN676
 MX Class 3 EN676
 FGR Ultra Low NOx

Head length: TC standard head
 TL extended head

Flame control system: FS1 Standard/Intermittent (at least 1 stop every 24 h)
 FS2 Continuous (1 stop every 72 h)

Electrical supply to the system:

1/230/50	1/230V/50Hz
3/230/50	3/230V/50Hz
3/400/50	3N/400V/50Hz
3/230-400/50	3/230V/50Hz - 3N/400V/50Hz
3/220/60	3/220V/60Hz
3/380/60	3N/380V/60Hz
3/220-380/60	3/220/60Hz - 3N/380V/60Hz

Auxiliary voltage: 230/50-60 230V/50-60H
 110/50-60 110V/50-60Hz

R S 310 /E FGR TC FS1 3/400/50 230/50-60

BASIC DESIGNATION

EXTENDED DESIGNATION

ULTRA LOW NOx
 GAS

Ultra Low NO_x Gas FGR Burners

RS 68÷2000/E FGR SERIES

Specification

STATE OF SUPPLY

Monoblock forced draught, Ultra Low NO_x gas burner with Flue Gas Recirculation (FGR) system, with modulating operation, fully automatic, made up of:

- High performance fan with low sound emissions
- Air suction circuit
- Air damper for air setting controlled by a high precision servomotor
- Air pressure switch
- Three-phase Fan starting motor
- Low emission combustion head, that can be set on the basis of required output, fitted with:
 - stainless steel end cone, resistant to corrosion and high temperatures
 - flame stability disk
- Automatic regulator for gas delivery, controlled by a high precision servomotor
- Burner Pilot Ignition system, with dedicated gas train, to assure a high ignition reliability
- Flue gas recirculation butterfly valve controlled by a high precision servomotor
- Flue gas recirculation temperature probe to prevent condensation in burner intake
- Maximum gas pressure switch, with pressure test point, to stop the burner in the case of excess pressure on the fuel supply line
- Electronic Cam control
 - for air/fuel setting
 - for output modulation with incorporated PID control of temperature or pressure of the heat generator
 - with indication of operating status and parameters, error messages and diagnosis of fault causes
- Operator panel with LCD Display Interface, for combustion system commissioning and monitoring
- Burner safety control included on Electronic Cam device
- UV sensor for flame detection
- Main electrical supply terminal board
- Burner on/off switch
- Manual or automatic output increase/decrease switch
- Contacts motor and thermal relay with release button
- Motor internal thermal protection
- Clean contacts relay
- Burner failure led signal and lighted release button
- Guides for opening the burner and inspecting the combustion head (RS 68 ÷ 200/E FGR)
- Hinge for opening the burner and inspecting the combustion head (RS 310 ÷ 2000/E FGR)
- Lifting rings

Standard equipment:

Thermal insulation screen

- Screws to fix the burner flange to the boiler
- Screws to fix the gas train flange
- Gasket for gas train flange
- Pressure switch for leak detection control of gas train
- Spare parts catalogue
- Instruction handbook for installation, use and maintenance

Available models

Burners

CODE	MODEL			HEAT OUTPUT NATURAL GAS		TOTAL ELECTRICAL POWER (kW)	CERTIFICATION	NOTE
				(kW)	(Nm ³ /h)			
On demand	RS 68/E FGR	TC FS1	3/400/50	195/350-810	20/35 - 81	2,1		(1)(2)
On demand	RS 120/E FGR	TC FS1	3/400/50	300/595 - 1150	30/60 - 115	2,9		(1)(2)
On demand	RS 160/E FGR	TC FS1	3/400/50	350/958 - 1849	35/96 - 185	5,3		(1)(2)
On demand	RS 200/E FGR	TC FS1	3/400/50	550/1372 - 2300	55/137 - 230	6,5		(1)(2)
On demand	RS 310/E FGR	TC FS1	3/400/50	400/1200 - 3630	40/120 - 363	9,1		(1)(2)
20162643	RS 410/E FGR	TC FS1	3/400/50	595/1210 - 3820	50/150 - 445	10,6	CE-0123CU1034	(1)(2)(4)
20162646	RS 510/E FGR	TC FS1	3/400/50	660/1800 - 4800	68/180 - 525	13,9	CE-0123CU1034	(1)(3)(4)
20162647	RS 610/E FGR	TC FS1	3/400/50	912/2220 - 5850	100/220 - 625	16,9	CE-0123CU1034	(1)(3)(4)
20160289	RS 810/E FGR	TC FS1	3/400/50	1100/3500 - 6990	120/350 - 700	24	CE-0123CU1078	(1)(3)(4)
On demand	RS 1000/E FGR	TC FS1	3/400/50	1100/4000 - 10100	110/400 - 1010	25,7		(1)(3)
On demand	RS 1200/E FGR	TC FS1	3/400/50	1500/5500 - 11100	150/550 - 1110	28,7		(1)(3)
On demand	RS 1300/E FGR	TC FS1	3/400/50	2500/7500 - 13000	250/750 - 1300	34,7		(1)(3)
On demand	RS 1600/E FGR	TC FS1	3/400/50	3065/9503 - 15560	307/950 - 1556	41,5		(1)(3)
On demand	RS 2000/E FGR	TC FS1	3/400/50	4000/12000 - 19500	400/1200 - 1950	49,3		(1)(3)
20162652	RS 410/EV FGR	TC FS1/FS2	3/400/50	595/1210 - 3820	50/150 - 445	10,6	CE-0123CU1034	(1)(4)
20162653	RS 510/EV FGR	TC FS1/FS2	3/400/50	660/1800 - 4800	68/180 - 525	13,9	CE-0123CU1034	(1)(4)
20162655	RS 610/EV FGR	TC FS1/FS2	3/400/50	912/2220 - 5850	100/220 - 625	16,9	CE-0123CU1034	(1)(4)

(1) Power range referred to a Low NO_x performance conforming to the Class 3 of EN676 European Standard, with 0% of Flue Gas Recirculation; by increasing the recirculation % in order to achieve an ULTRA Low NO_x emission the burner's maximum output will be reduced

(2) Direct starter fan motor

(3) Star delta fan motor starter

(4) (1) according to 2016/426/EU - 2014/35/EU - 2014/30/EU - 2014/68/EU - 2006/42 EC Directive.

For more information about product codes, please contact Riello Burners Commercial and Technical Department, our Application Engineers will be pleased to help you.

Ultra Low NOx Gas FGR Burners

RS 68÷2000/E FGR SERIES

Available models

Gas Trains

CODE	GAS TRAIN MODEL	Ø	ADAPTER CODE			
			RS 68	RS 120	RS 160	RS 200
3970258*	MB 410/1 - RT 52	Rp 1" ¼		3010126	●	●
3970600*	MB 410/1 - RT 52	Rp ¾"	3000824 + 3000843		●	●
3970256*	MB 412/1 - RT 52	Rp 1" ½		3000843		●
3970250*	MB 415/1 - RT 52	Rp 1" ½		3000843		
3970257*	MB 420/1 - RT 52	Rp 2"		□		
3970221*	MBC 1200/1 - RSM 60	Rp 2"		□		
3970222*	MBC 1900/1 - FSM 40	DN 65		3000825		
3970223*	MBC 3100/1 - FSM 40	DN 80		3000826		
3970224*	MBC 5000/1 - FSM 80	DN 100	●	●	●	3010370 + 3000826
3970145*	CB 512/1 - RSM 30	Rp 1" ½		3000843		
3970146*	CB 520/1 - RSM 30	Rp 2"		□		
20044659*	CB 525/1 - RSM 30	Rp 2"		□		
3970147*	CB 5065/1 - FSM 30	DN 65		3000825		
3970148*	CB 5080/1 - FSM 30	DN 80		3000826		
3970149*	CB 50100/1 - FSM 30	DN 100		3010370 + 3000826		
20015871*	CB 50125/1 - FSM 30	DN 125	●	3010224 + 3000826		

Please see designation of Gas Train Series in the page before the Catalogue index.

* 230V/50Hz -220V/60Hz electrical supply.

The valves seal control device is compulsory (conforming to EN 676) on gas trains to burners with a maximum output over 1200 kW.

The seal control function is managed by REC control box, by installation on gas train of a pressure switch (please see Gas train accessories paragraph); it is included as standard equipment on RS 120/E-EV-160/E-EV-200/E-EV BLU models.

To select the gas train please refer to the instruction manual.

● Not available.

□ Additional adapter not necessary, the gas train may be connected directly to the burner.

CODE	GAS TRAIN MODEL	Ø	ADAPTER CODE			
			RS 310	RS 410	RS 510	RS 610
3970250*	MB 415/1 - RT 52	Rp 1" ½	3000826 + 20064220	●	●	●
3970257*	MB 420/1 - RT 52	Rp 2"	3000826 + 20042324	●	●	●
3970221*	MBC 1200/1 - RSM 60	Rp 2"		3000826 + 20042324		
3970222*	MBC 1900/1 - FSM 40	DN 65		3010221		
3970223*	MBC 3100/1 - FSM 40	DN 80		3010222		
3970224*	MBC 5000/1 - FSM 80	DN 100		3010222 - 3010370		
3970145*	CB 512/1 - RSM 30	Rp 1" ½	3000826 + 20064220		●	●
3970146*	CB 520/1 - RSM 30	Rp 2"		3000826 + 20042324		●
20044659*	CB 525/1 - RSM 30	Rp 2"		3000826 + 20042324		
3970147*	CB 5065/1 - FSM 30	DN 65		3010221		
3970148*	CB 5080/1 - FSM 30	DN 80		3010222		
3970149*	CB 50100/1 - FSM 30	DN 100		3010223 - 3010370		
20015871*	CB 50125/1 - FSM 30	DN 125		3010224		

Please see designation of Gas Train Series in the page before the Catalogue index.

* 230V/50Hz -220V/60Hz electrical supply.

** 230V/50Hz electrical supply.

The valves seal control device is compulsory (conforming to EN 676) on gas trains to burners with a maximum output over 1200 kW.

The seal control function is managed by REC control box, by installation on gas train of a pressure switch (please see Gas train accessories paragraph).

To select the gas train please refer to the instruction manual.

● Not available.

□ Additional adapter not necessary, the gas train may be connected directly to the burner.

Available models

Gas Trains

CODE	GAS TRAIN		VPS CODE	ADAPTER CODE		
	MODEL	∅		RS 810	RS 1000	RS 1200
3970221*	MBC 1200/1 - RSM 60	Rp 2"	3010123	20042324 + 20064169 / (20068062) ¹	20066263 / (20065924 + 20066263) ¹	
3970222*	MBC 1900/1 - FSM 40	DN 65	3010123	20059330 / (20065924 + 20059330) ¹ / (3010221 + 20059331) ²	20066263 / (20065924 + 20066263) ¹	
3970223*	MBC 3100/1 - FSM 40	DN 80	3010123	20059331 / (20065937 + 20059331) ¹ / (3010222 + 20059331) ²	20066268 / (20065937 + 20066268) ¹	
3970224*	MBC 5000/1 - FSM 80	DN 100	3010123	20059332 / (20065960 + 20059332) ¹ / (3010223 + 20059331) ²	20066278 / (20065960 + 20066278) ¹	
3970147*	CB 5065/1 - FSM 30	DN 65	3010123	20059330 / (20065924 + 20059330) ¹ / (3010221 + 20059331) ²	20066263 / (20065924 + 20066263) ¹	
3970148*	CB 5080/1 - FSM 30	DN 80	3010123	20059331 / (20065937 + 20059331) ¹ / (3010222 + 20059331) ²	20066268 / (20065937 + 20066278) ¹	
3970149*	CB 50100/1 - FSM 30	DN 100	3010123	20059332 / (20065960 + 20059332) ¹ / (3010223 + 20059331) ²	20066278 / (20065960 + 20066268) ¹	
20015871*	CB 50125/1 - FSM 30	DN 125	3010123	20059333 / (20065968 + 20059333) ¹ / (3010224 + 20059331) ²	20066284 / (20065968 + 20066284) ¹	

Please see designation of Gas Train Series in the page before the Catalogue index.

* 230V/50Hz - 220V/60Hz electrical supply.

The valve seal control device is compulsory (conforming to EN 676) on gas trains to burners with a maximum output over 1200 kW.

The seal control function is managed by LMV control box, by installation on gas train of a pressure switch supplied, as standard equipment with the burner.

To select the gas train please refer to the technical data leaflet and/or instruction manual.

1) To be used with gas train and burner opening on the left (fan motor side).

CODE	GAS TRAIN			CQ KIT CODE	ADAPTER CODE	
	MODEL	∅	◆		RS 1300	RS 1600 - 2000
3970223	MBC 3100/1 - FSM 40	DN 80	-	3010344	20130713	20130602
20093449	MBC 3100/1 CQ FSM 40	DN 80	CQ	-	20130713	20130602
3970224	MBC 5000/1 - FSM 80	DN 100	-	3010344	20130602	20130616
20093452	MBC 5000/1 CQ FSM 80	DN 100	CQ	-	20130602	20130616
3970149	CB 50100/1 - FSM 30	DN 100	-	3010344	20130602	20130616
20015871	CB 50125/1 - FSM 30	DN 125	-	3010344	20130606	20130617
20043047	DMV 50100/1 - FSM -0	DN 100	-	3010344	20130602	20130616
20043049	DMV 50100/1 CQ FSM -2	DN 100	CQ	-	20130602	20130616
20043050	DMV 50125/1 - FSM -0	DN 125	-	3010344	20130606	20130617
20043052	DMV 50125/1 CQ FSM -2	DN 125	CQ	-	20130606	20130617

Please see designation of Gas Train Series in the page before the Catalogue index.

- ◆ Gas valve leak detection control device:
- gas train not equipped with leak detection control device; this device can be ordered separately - see VPS column - and installed later.
- CQ KIT Additional pressure switch for leak detection control in combination with burners /E and /EV.
Gas train not available or not suitable for the matching to the burner.

Ultra Low NOx Gas FGR Burners

RS 68÷2000/E FGR SERIES

Burner accessories

Extended head kit

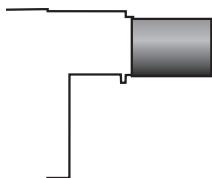

“Standard head” burners can be transformed into “extended head” versions, by using the special kit. The KITS available for the various burners, giving the original and the extended lengths, are listed below.

BURNER	STANDARD HEAD LENGTH (mm)	EXTENDED HEAD LENGTH (mm)	KIT CODE
▶ RS 160/E FGR	373	503	20131539
▶ RS 200/E FGR	373	503	20131510

Accessories for modulating operation



The control box of RS /E FGR Burners includes the three point PID regulator to obtain the modulating operation. The relative temperature or pressure probes fitted to the regulator must be chosen on the basis of the application.

BURNER	PROBE TYPE	RANGE (°C) (bar)	PROBE CODE
▶ All models	Temperature PT 100	-100 ÷ 500°C	3010110
	Pressure 4 ÷ 20 mA	0 ÷ 2,5 bar	3010213
	Pressure 4 ÷ 20 mA	0 ÷ 16 bar	3010214
	Pressure 4 ÷ 20 mA	0 ÷ 25 bar	3090873

DN80 gas flange kit

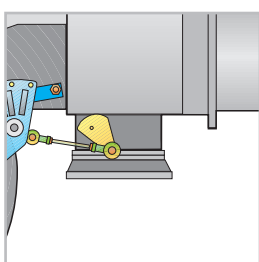

To modify the standard 2” burner gas input connection in to DN80 connection, a specific gas flange is available.

BURNER	KIT CODE
▶ RS 68 - 120 - 160 - 200/E FGR	3010439

PC Interface Software

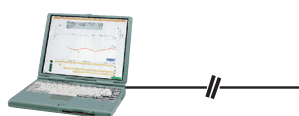

PC tool for convenient programming and burner settings, process visualization, data recording, selection of AZL language, software update AZL.

BURNER	KIT CODE
▶ RS 68 - 120 - 160 - 200/E FGR	On demand
▶ RS 310 - 410 - 510 - 610 - 810/E FGR	
▶ RS 1000 - 1200/E FGR	
▶ RS 1300 - 1600 - 2000/E FGR	

RIELLO 40 F SERIES

The Riello 40 F series of one stage light oil burners, is a complete range of products developed to respond to any request for light industrial applications. The Riello 40 F series is available in three different models, with an output ranging from 30 to 202 kW, divided in three different structures.

All the models use the same components designed by Riello for the Riello 40 F series. The high quality level guarantees safe working.

In developing these burners, special attention was paid to reducing noise, to the ease of installation and adjustment, to obtaining the smallest size possible to fit into any sort of boiler available on the market.

All the models are approved by the EN 267 European Standard and conform to European Directives for EMC, Low Voltage, Machinery and Boiler Efficiency.

All the Riello 40 F burners are fired before leaving the factory.

Guidelines for installation of burners in conformity to EU Regulation:

A RIELLO burner (Heat Generator), where it is matched with a water-based boiler (Heater Housing) with a nominal output ≤ 400 kW, providing heat for heating purposes and heat to deliver sanitary hot water, can be installed:

- With boilers (heater housings) already in service in the field, for replacement of identical products, in conformity to Article 1, paragraph 2, point (G) of the EU Regulation No. 813/2013;
- With boilers (heater housings) on a new installation.



F5	30 ÷ 60 kW
F10	54 ÷ 107 kW
F20	95 ÷ 202 kW

FIRING RATES

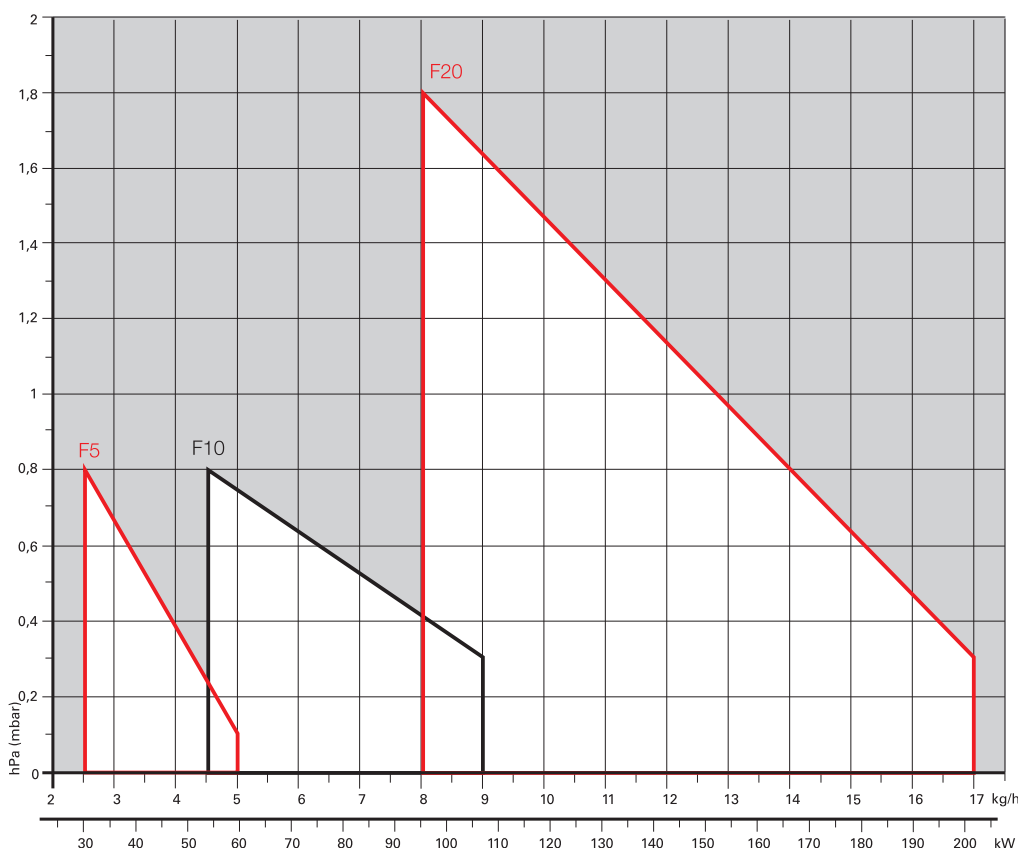

Useful working field for choosing the burner

Test conditions conforming to EN267
 Temperature: 20°C
 Pressure: 1013,5 mbar
 Altitude: 0 m a.s.l.

Light Oil Oven Burners

RIELLO 40 F SERIES

Overall dimensions (mm)

BURNER

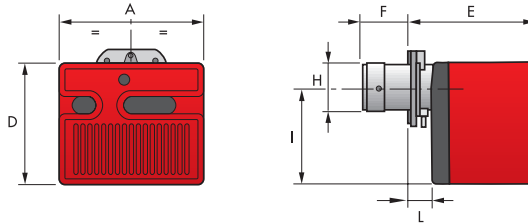

MODEL	A	D	E	F	H	I	L
► F5	272	233	240	72	89	180	41
► F10	305	262	265	104	105	204	44
► F20	350	298	299	118	125	230	45

BURNER - BOILER MOUNTING FLANGE

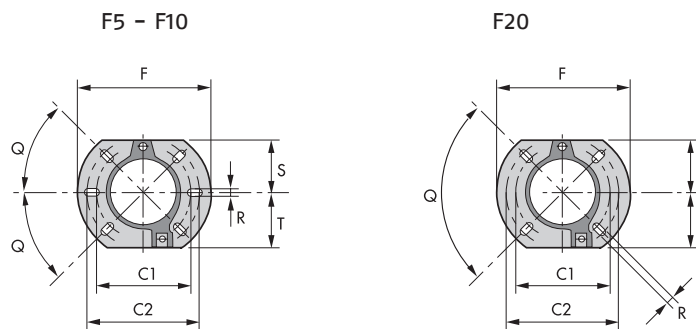

MODEL	C1	C2	F	Q	R	S	T
► F5	130	150	180	45°	11	72	75
► F10	140	170	189	45°	11	83	83
► F20	160	190	213	90°	11	99	99

PACKAGING

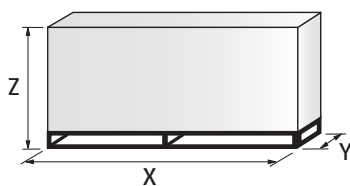

MODEL	X	Y	Z	kg
► F5	383	315	325	12
► F10	423	348	340	13
► F20	483	393	377	16

RIELLO 40 F SERIES

Specification

DESIGNATION OF SERIES

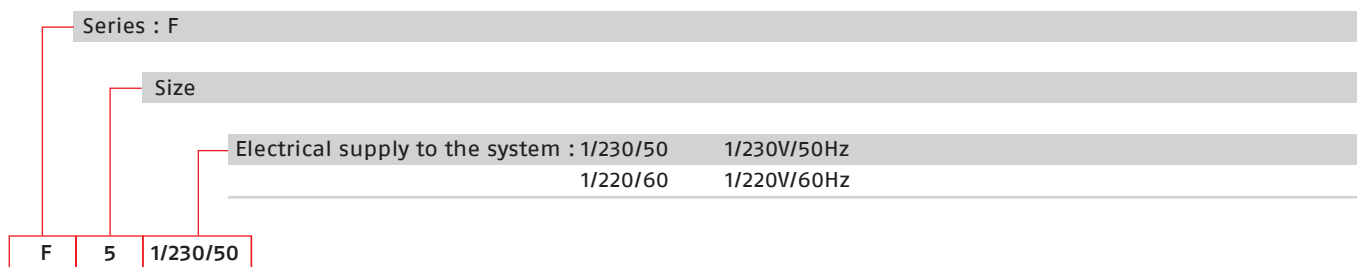

STATE OF SUPPLY

Completely automatic monobloc light oil burners, one stage operation, made up of:

- Fan with forward curve blades
- Metallic cover
- Fixed air damper with adjustment
- Single phase electric motor 230 V, 50 Hz
- Combustion head fitted with:
 - stainless steel head cone, resistant to high temperatures
 - ignition electrodes
 - flame stability disk
- Geared pump for fuel supply, fitted with:
 - filter
 - pressure regulator
 - attachments for fitting a pressure gauge and vacuum meter
 - internal by-pass for preparing for single-pipe installations
- Fuel feed solenoid valve incorporated in the pump
- Photocell for flame detection
- Electronic flame control equipment
- Light oil nozzle
- IP X0D (IP 40) protection level.

Standard equipment:

- Two flexible pipes for connection to the light oil supply line
- Two nipples for connection to the pump
- Flange, screws and nuts for fixing
- Thermal screen
- Instruction handbook for installation, use and maintenance
- Spare parts catalogue.

Available models

CODE	MODEL	HEAT OUTPUT		TOTAL ELECTRICAL POWER (kW)	NOTE
		(kW)	(kg/h)		
3451083	F5	1/230/50	30 - 60	2,5 - 5	0,130
3746159	F5	1/220/60	30 - 60	2,5 - 5	0,180
3452083	F10	1/230/50	54 - 107	4,5 - 9	0,170
3746260	F10	1/220/60	54 - 107	4,5 - 9	0,200
3452783	F20	1/230/50	95 - 202	8 - 17	0,320
3747260	F20	1/220/60	95 - 213	8 - 18	0,400

Net calorific value: 11,8 kWh/kg - 10200 kcal/kg - Viscosity at 20°C: 4±6 mm²/s (cSt)
The burners of F series are in according to EN 267.

Bio fuels

Riello Burners is able to offer technical variants which allow burners to be used within environmental heating, process or special applications. These applications now include solutions for liquid Bio fuels (i.e. biodiesel and vegetable oil). Our experience in research and development and field applications with organic origin Bio fuels has resulted in Riello being able to offer a wide range of solutions for the combustion of Bio fuels.

Burner accessories

Remote control release kit for 530 SE control box

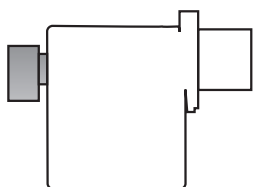

The 530 SE control box can be remotely released using an electric command kit. This kit must be installed in conformity with current regulations in force.

BURNER	KIT CODE
► F5 - F10 - F20	3001030

Extended head kit

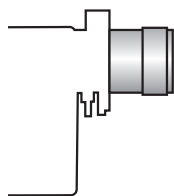

Kits of extended heads are available.

BURNER	STANDARD HEAD LENGTH (mm)	EXTENDED HEAD LENGTH (mm)	KIT CODE
► F5	72	107	3000638
► F10	104	168	3000643
► F10	104	250	3000770
► F20	118	178	3000644
► F20	118	260	3000771

Burner accessories

Spacer kit

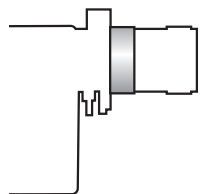

Using the special accessories, the burner can be pulled back to reduce head penetration into the combustion chamber.

BURNER	SPACER THICKNESS S (mm)	KIT CODE
▶ F5	25	3000642
▶ F10	25	3000672
▶ F20	15	20103452

Inlet air aspiration kit

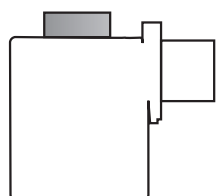

This kit allows to channel the external air directly into the burner and is available as accessory for models:

BURNER	KIT CODE
▶ F5	20027574
▶ F10	20027577
▶ F20	20027580

Light oil filter



For cleaning light oil from dirty particles and impurities filters with the following features are available:

BURNER	FILTERING DEGREE (µm)	KIT CODE
▶ All models	60	3006561

Filter made up of aluminium body and stainless steel filtering cartridge; available singularly.

BURNER	FILTERING DEGREE (µm)	KIT CODE
▶ All models	60	3075011

Filter made up of aluminium cover, plastic tank and nylon filtering cartridge; available in packaging of 50 pieces.

Light oil filter/degassing unit



To solve problems of air or water in the oil circuit a special filter/degassing unit is available, made up of aluminium cover, plastic tank, stainless steel filtering cartridge, air release cap and water purge valve. It is available singularly.

BURNER	FILTERING DEGREE (µm)	KIT CODE
▶ All models	100	3000926

7-pin plug kit

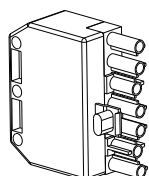

If necessary a 7-pin plug kit is available (in packaging of n. 5 pieces).

BURNER	KIT CODE
▶ All models	3000945

Light Oil Oven Burners

RIELLO 40 F SERIES

Burner accessories

Hour counter kit for 530 SE and 531 SE control boxes



To measure the burner working time a hour counter kit is available.

BURNER	KIT CODE
► All models	3000904

7-pole socket kit for 530 SE and 531 SE control boxes

For burner without pre installed socket a 7-pole socket kit with cable is available.

BURNER	KIT CODE
► All models	3001065

GULLIVER RGF SERIES

The Riello Gulliver RGF series of one stage light oil burners, is a complete range of products developed to respond to any request for light industrial processes like bakery ovens, spray painting ovens, small steam or thermal boilers and all applications which require a reliable, user-friendly industrial product with enhanced performance and specific functions.

The Gulliver RGF series is available in four different models, with an output ranging from 32 to 237 kW, divided in three different structures.

All the models use the same components designed by Riello for the Gulliver series and have the same ventilation system and overall dimensions as the previous one stage light oil models.

This new series can operate on 50 or 60 Hz and a Voltage 220 – 230 Volt (dual frequency).

All these burners conform to the EN 267 Standard (Forced draught oil burners) and to European Directives for EMC, Low Voltage and Machinery. For depressurised working field see EN 746-2 Standard.

All the Gulliver RGF burners are fired before leaving the factory.

Guidelines for installation of burners in conformity to EU Regulation:

A RIELLO burner (Heat Generator), where it is matched with a water-based boiler (Heater Housing) with a nominal output ≤ 400 kW, providing heat for heating purposes and heat to deliver sanitary hot water, can be installed:

- With boilers (heater housings) already in service in the field, for replacement of identical products, in conformity to Article 1, paragraph 2, point (G) of the EU Regulation No. 813/2013;
- With boilers (heater housings) on a new installation.



RG1F	32,0 ÷ 60,0 kW
RG2F	47,0 ÷ 119,0 kW
RG3F	83,0 ÷ 178,0 kW
RG4F	118,5 ÷ 237,0 kW

Light Oil Oven Burners

GULLIVER RGF SERIES

FIRING RATES

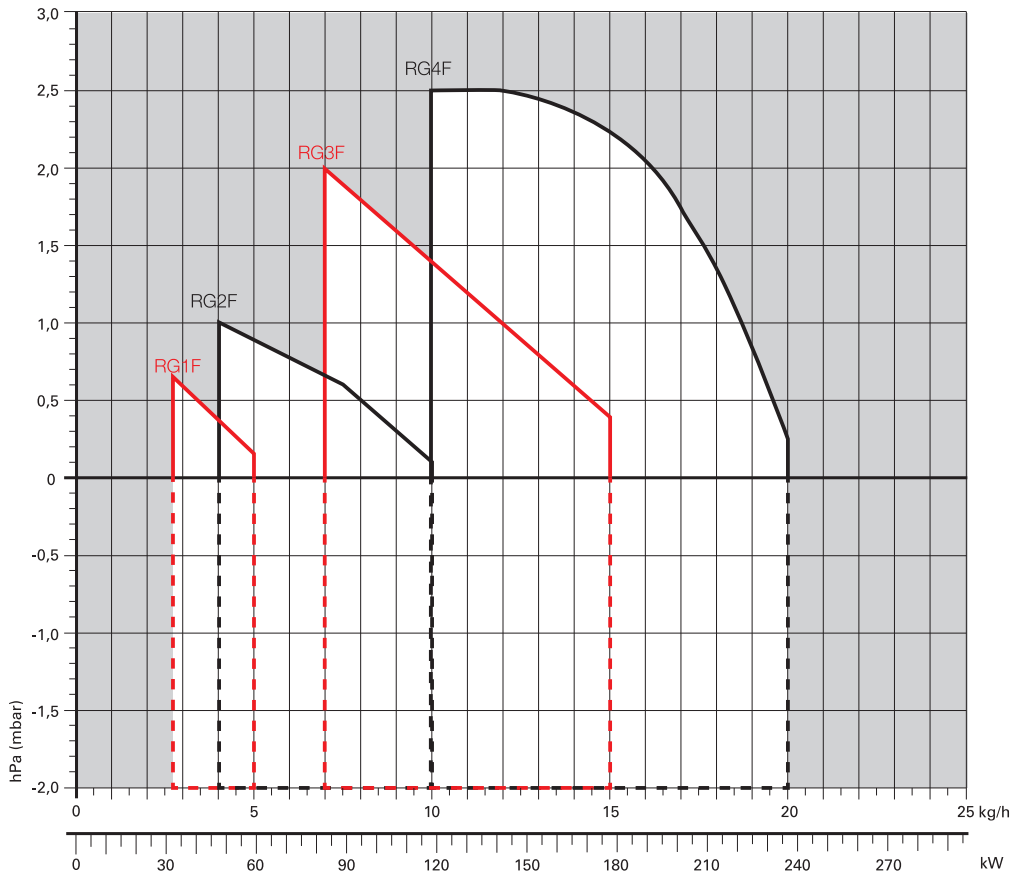

Useful working field for choosing the burner

Test conditions conforming to EN267
 Temperature: 20°C
 Pressure: 1013,5 mbar
 Altitude: 0 m a.s.l.

IMPORTANT:
 For the part of the working field that is depressurised, refer to EN 746-2 Standard.

Overall dimensions (mm)

BURNER

GULLIVER RG1F

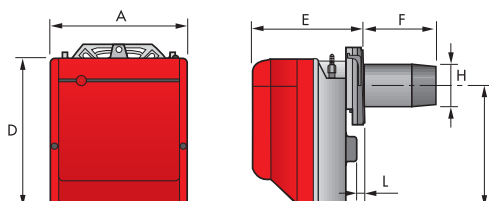

GULLIVER RG2F - RG3F - RG4F

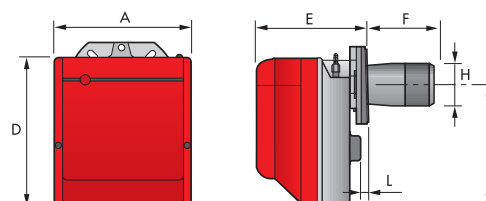

MODEL	A	D	E	F	H	I	L
▶ RG1F	234	254	196	93	84	210	4
▶ RG2F	255	280	202	115	95	230	10
▶ RG3F	300	345	228	142	123	285	12
▶ RG4F	300	345	228	142	125	285	12

BURNER - BOILER MOUNTING FLANGE

GULLIVER RG1F - RG2F

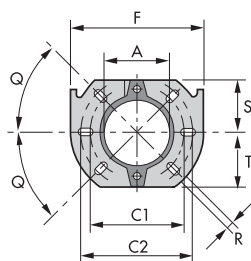

GULLIVER RG3F - RG4F

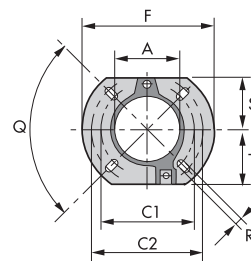

MODEL	A	C1	C2	F	Q	R	S	T
▶ RG1F	91	130	150	180	45°	11	72	72
▶ RG2F	106	140	168	189	45°	11	83	83
▶ RG3F	127	160	190	213	90°	11	99	99
▶ RG4F	127	160	190	213	90°	11	99	99

PACKAGING

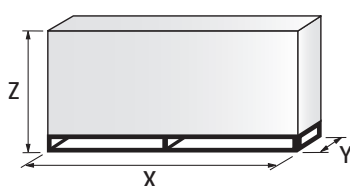

MODEL	X	Y	Z	kg
▶ RG1F	353	278	320	13
▶ RG2F	363	298	350	13
▶ RG3F	430	345	430	15
▶ RG4F	430	345	430	18

Light Oil Oven Burners

GULLIVER RGF SERIES

Specification

DESIGNATION OF SERIES

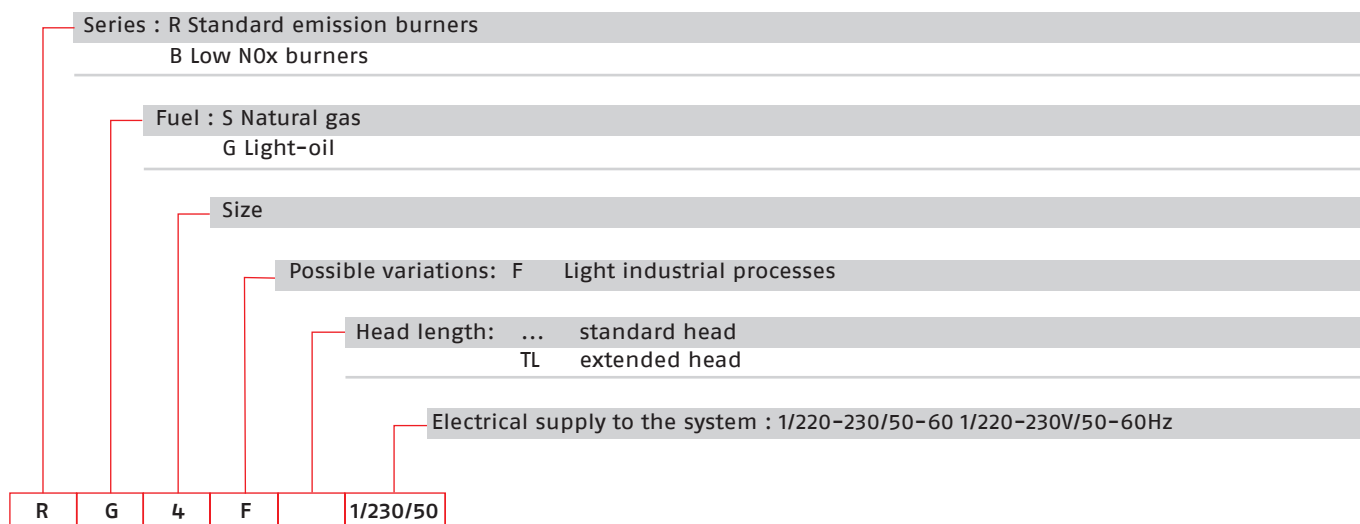

STATE OF SUPPLY

Completely automatic monobloc light oil burners, with one stage operation fitted with:

- Fan with forward curve blades
- Cover lined with sound - proofing material
- Air damper, always open in stand by, with external adjustment, without need to remove the cover
- Single phase electric motor 220 - 230 V, 50 - 60 Hz
- Combustion head fitted with:
 - stainless steel head cone, resistant to high temperatures
 - ignition electrodes
 - flame stability disk
- Geared pump for fuel supply, fitted with:
 - filter
 - pressure regulator
 - attachments for fitting a pressure gauge and vacuum meter
 - internal by-pass for preparing for single-pipe installations
- Fuel feed solenoid valve incorporated in the pump
- Photocell for flame detection
- Electronic flame control equipment
- Light oil nozzle
- IP X0D (IP 40) protection level

Standard equipment:

- Flange with insulating gasket
- Screw and nuts for flange
- 7-pin plug
- Screw and nuts for flange to be fixed to the heat generator
- Flexible oil pipes with nipples
- Instruction handbook for installation, use and maintenance
- Spare parts catalogue.

Available models

CODE	MODEL	HEAT OUTPUT		TOTAL ELECTRICAL POWER (kW)	NOTE
		(kW)	(kg/h)		
3736370	RG1F 1/220-230/50-60	32 - 60	2,7 - 5	0,155 (at 50Hz) - 0,200 (at 60 Hz)	
3737770	RG2F 1/220-230/50-60	47 - 119	4 - 10	0,165 (at 50Hz) - 0,220 (at 60 Hz)	
3739380	RG3F 1/220-230/50-60	83 - 178	7 - 15	0,380 (at 50Hz) - 0,520 (at 60 Hz)	
3739680	RG4F 1/220-230/50-60	118,5 - 237	10 - 20	0,370 (at 50Hz) - 0,510 (at 60 Hz)	

Net calorific value: 11,8 kWh/kg; 10200 kcal/kg - Viscosity at 20°C: 4±6 mm²/s (cSt).
The burners of RGF series are in according to EN 267 and 746-2.

Burner accessories

Extended head kit

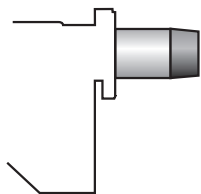

Kits of extended heads are available.

BURNER	STANDARD HEAD LENGTH (mm)	EXTENDED HEAD LENGTH (mm)	KIT CODE
▶ RG1F	93	163	3000963
▶ RG2F	115	180	3000964
▶ RG2F	115	300	3000967
▶ RG3F	142	210	3000965
▶ RG3F	142	300	3000968
▶ RG4F	142	210	3000966
▶ RG4F	142	300	3000969

Spacer kit

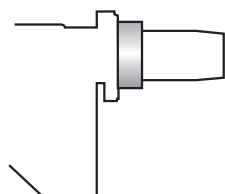

By using the special accessories, the burner can be with-drawn to reduce head penetration into the combustion chamber.

BURNER	SPACER THICKNESS S (mm)	KIT CODE
▶ RG1F	15	3007931
▶ RG2F	25	3000672
▶ RG3F - RG4F	15	20103452

Pre-heater kit

This kit is used only for Gulliver RG1F burner. It can be installed in special atmospheric conditions (low temperatures), with high diesel oil viscosity and with low deliveries.

BURNER	KIT CODE
▶ RG1F	3001083

Light Oil Oven Burners

GULLIVER RGF SERIES

Burner accessories

Light oil filter



For cleaning light oil from dirty particles and impurities filters with the following features are available:

BURNER	FILTERING DEGREE (μm)	KIT CODE
► All models	60	3006561

Filter made up of aluminium body and stainless steel filtering cartridge; available singularly.

BURNER	FILTERING DEGREE (μm)	KIT CODE
► All models	60	3075011

Filter made up of aluminium cover, plastic tank and nylon filtering cartridge; available in packaging of 50 pieces.

Light oil filter/degassing unit



To solve problems of air or water in the oil circuit a special filter/degassing unit is available, made up of aluminium cover, plastic tank, stainless steel filtering cartridge, air release cap and water purge valve. It is available singularly.

BURNER	FILTERING DEGREE (μm)	KIT CODE
► All models	100	3000926

7-pin plug kit

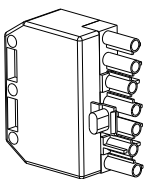

If necessary a 7-pin plug kit is available (in packaging of n. 5 pieces).

BURNER	KIT CODE
► All models	3000945

GULLIVER RGDF SERIES

The Riello Gulliver RG5DF is a new model of one stage light oil burner, developed to respond to any request for light industrial processes like bakery ovens, spray painting ovens, small steam or thermal boilers and all applications which require a reliable, user-friendly industrial product with enhanced performance and specific functions.

This model uses the same components designed by Riello for the Gulliver series and has the same ventilation system and overall dimensions as the previous two stage light oil model.

This new burner can operate on 50 or 60 Hz and a Voltage 220 - 230 Volt (dual frequency). It is conform to the EN 267 Standard (Forced draught oil burners) and to European Directives for EMC, Low Voltage and Machinery. For depressurised working field see EN 746-2 Standard.

The Gulliver RG5DF burner is fired before leaving the factory.

Guidelines for installation of burners in conformity to EU Regulation:

A RIELLO burner (Heat Generator), where it is matched with a water-based boiler (Heater Housing) with a nominal output ≤ 400 kW, providing heat for heating purposes and heat to deliver sanitary hot water, can be installed:

- With boilers (heater housings) already in service in the field, for replacement of identical products, in conformity to Article 1, paragraph 2, point (G) of the EU Regulation No. 813/2013;
- With boilers (heater housings) on a new installation.



RG5DF

95/142 ÷ 296 kW

FIRING RATES

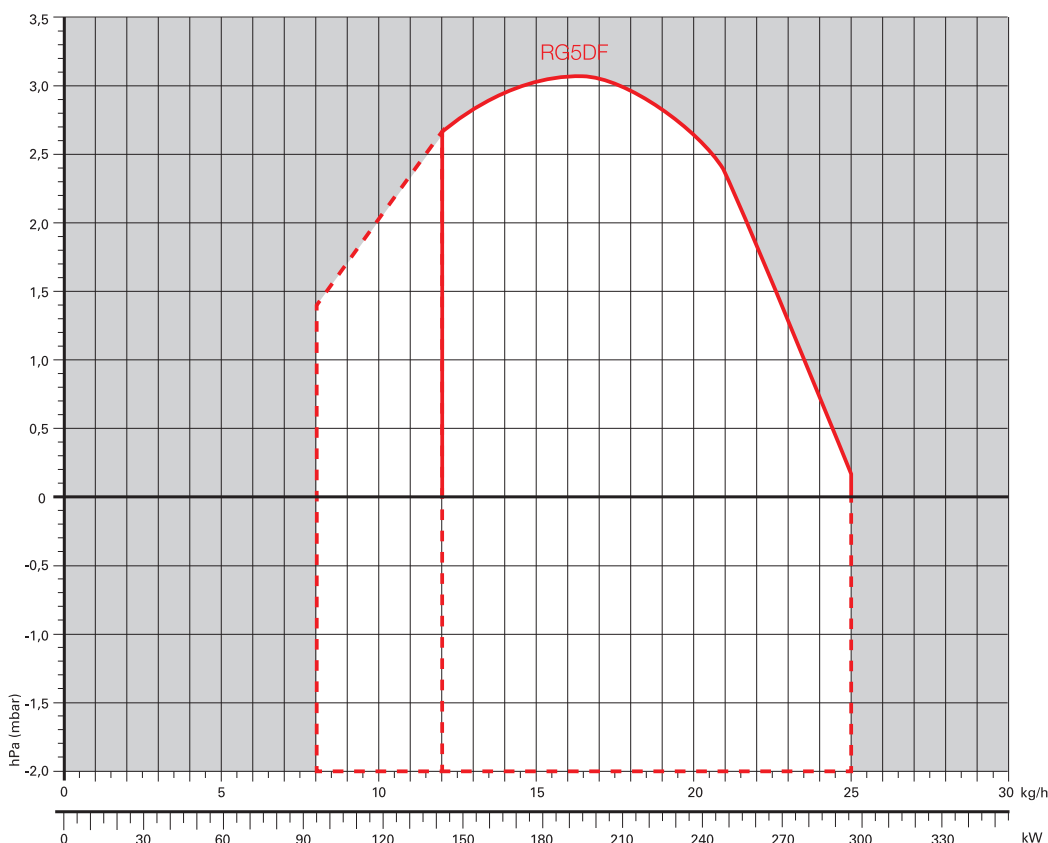

Useful working field for choosing the burner



1st stage operation range

Test conditions conforming to EN267
 Temperature: 20°C
 Pressure: 1013,5 mbar
 Altitude: 0 m a.s.l.

IMPORTANT:
 For the part of the working field that is depressurised, refer to EN 746-2 Standard.

Light Oil Oven Burners

GULLIVER RGDF SERIES

Overall dimensions (mm)

BURNER

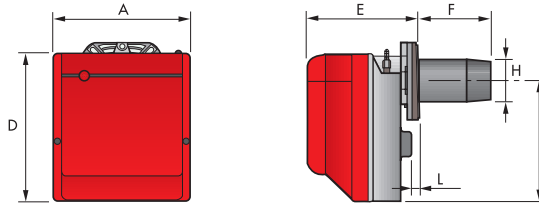

MODEL	A	D	E	F	H	I	L
► RG5DF	300	345	247	159	125	285	12,5

BURNER - BOILER MOUNTING FLANGE

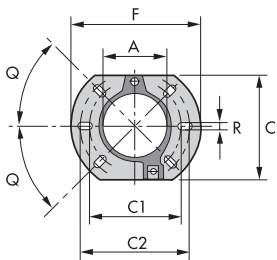

MODEL	A	C	C1	C2	F	Q	R
► RG5DF	127	198	160	190	213	45°	11

PACKAGING

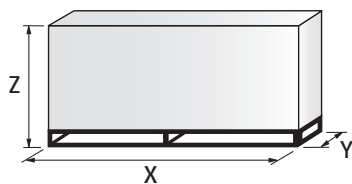

MODEL	X	Y	Z	kg
► RG5DF	510	345	440	18

Specification

DESIGNATION OF SERIES

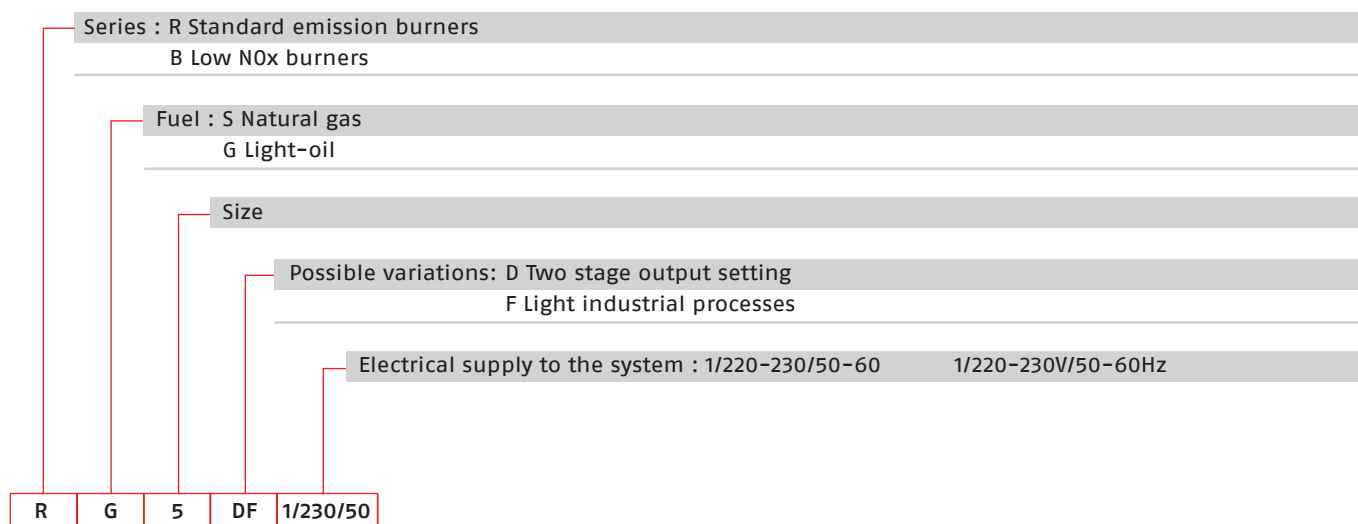

STATE OF SUPPLY

Completely automatic monobloc light oil burners, with two stage operation fitted with:

- Fan with forward curve blades
- Cover lined with sound-proofing material
- Air damper always open in stand-by
- Air damper, with 1st and 2nd stage adjustment (2nd stage adjustment without removing the casing)
- Single phase electric motor 220 - 230 V/ 50 - 60 Hz
- Combustion head fitted with:
 - stainless steel head cone, resistant to high temperatures
 - ignition electrodes
 - flame stability disk
- Geared pump for fuel supply, fitted with:
 - filter
 - pressure regulator
 - attachments for fitting a pressure gauge and vacuum meter
 - internal by-pass for preparing for single-pipe installations
- Fuel feed solenoid valve incorporated in the pump
- Photocell for flame detection
- Electronic flame control equipment
- Light oil nozzle
- IP X0D (IP 40) protection level.

Standard equipment

- Flange with insulating gasket
- Screw and nuts for flange
- Screws and nuts for flange to be fixed to the heat generator
- Flexible oil pipes with nipples
- 7-pin plug
- 4-pin plug
- Instruction handbook for installation, use and maintenance
- Spare parts catalogue.

Light Oil Oven Burners

GULLIVER RGDF SERIES

Available models

CODE	MODEL	HEAT OUTPUT		TOTAL ELECTRICAL POWER (kW)	NOTE
		(kW)	(kg/h)		
3739870	RG5DF 1/220-230/50-60	95/142 - 296	8/12 - 25	0,400 (at 50 Hz) - 0,575 (at 60 Hz)	

Net calorific value: 11,8 kWh/kg; 10200 kcal/kg - Viscosity at 20°C: 4±6 mm²/s (cSt).
The burners of RGDF series are in according to EN 267 and 746-2.

Burner accessories

Extended head kit

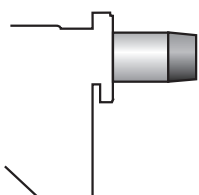

Kits of extended heads are available.

BURNER	STANDARD HEAD LENGTH (mm)	EXTENDED HEAD LENGTH (mm)	KIT CODE
▶ RG5DF	159	300	3000981

Spacer kit

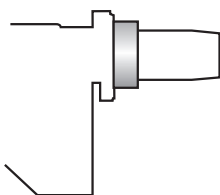

By using the special accessories, the burner can be with-drawn to reduce head penetration into the combustion chamber.

BURNER	SPACER THICKNESS S (mm)	KIT CODE
▶ RG5DF	15	20103452

Light oil filter



For cleaning light oil from dirty particles and impurities filters with the following features are available:

BURNER	FILTERING DEGREE (µm)	KIT CODE
▶ RG5DF	60	3006561

Filter made up of aluminium body and stainless steel filtering cartridge; available singularly.

BURNER	FILTERING DEGREE (µm)	KIT CODE
▶ RG5DF	60	3075011

Filter made up of aluminium cover, plastic tank and nylon filtering cartridge; available in packaging of 50 pieces.

Light oil filter/degassing unit



To solve problems of air or water in the oil circuit a special filter/degassing unit is available, made up of aluminium cover, plastic tank, stainless steel filtering cartridge, air release cap and water purge valve. It is available singularly.

BURNER	FILTERING DEGREE (µm)	KIT CODE
▶ RG5DF	100	3000926

7-pin plug kit

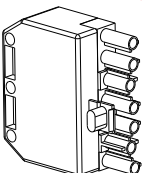

If necessary a 7-pin plug kit is available (in packaging of n. 5 pieces).

BURNER	KIT CODE
▶ RG5DF	3000945

GULLIVER BSF SERIES

GULLIVER BSF SERIES

The Riello Gulliver BSF series of one stage gas burners, is a complete range of products developed to respond to any request for light industrial processes like bakery ovens, spray painting ovens, small steam or thermal boilers and all applications which require a reliable, user-friendly industrial product with enhanced performance and specific functions.

The Gulliver BSF series is available in four different models, with an output ranging from 16 to 246 kW, divided in four different structures.

All the models use the same components designed by Riello for the Gulliver series and have the same ventilation system and overall dimensions as the previous one stage gas models.

The burners are fitted with a microprocessor-based burner safety control box which supplies indication of operation and diagnosis of fault cause.

This new series can operate on 50 or 60 Hz and a Voltage 220 - 230 Volt (dual frequency).

All these burners conform to the EN 676 Standard (Forced draught gas burners) and to European Directives for EMC, Low Voltage and Gas Appliance.

For depressurised working field see EN 746-2 Standard.

All the Gulliver BSF burners are fired before leaving the factory.

Guidelines for installation of burners in conformity to EU Regulation:

A RIELLO burner (Heat Generator), where it is matched with a water-based boiler (Heater Housing) with a nominal output ≤ 400 kW, providing heat for heating purposes and heat to deliver sanitary hot water, can be installed:

- With boilers (heater housings) already in service in the field, for replacement of identical products, in conformity to Article 1, paragraph 2, point (G) of the EU Regulation No. 813/2013;
- With boilers (heater housings) on a new installation.



BS1F	16	÷	52	kW
BS2F	35	÷	92	kW
BS3F	65	÷	197	kW
BS4F	110	÷	249	kW

Gas Oven Burners

GULLIVER BSF SERIES

FIRING RATES

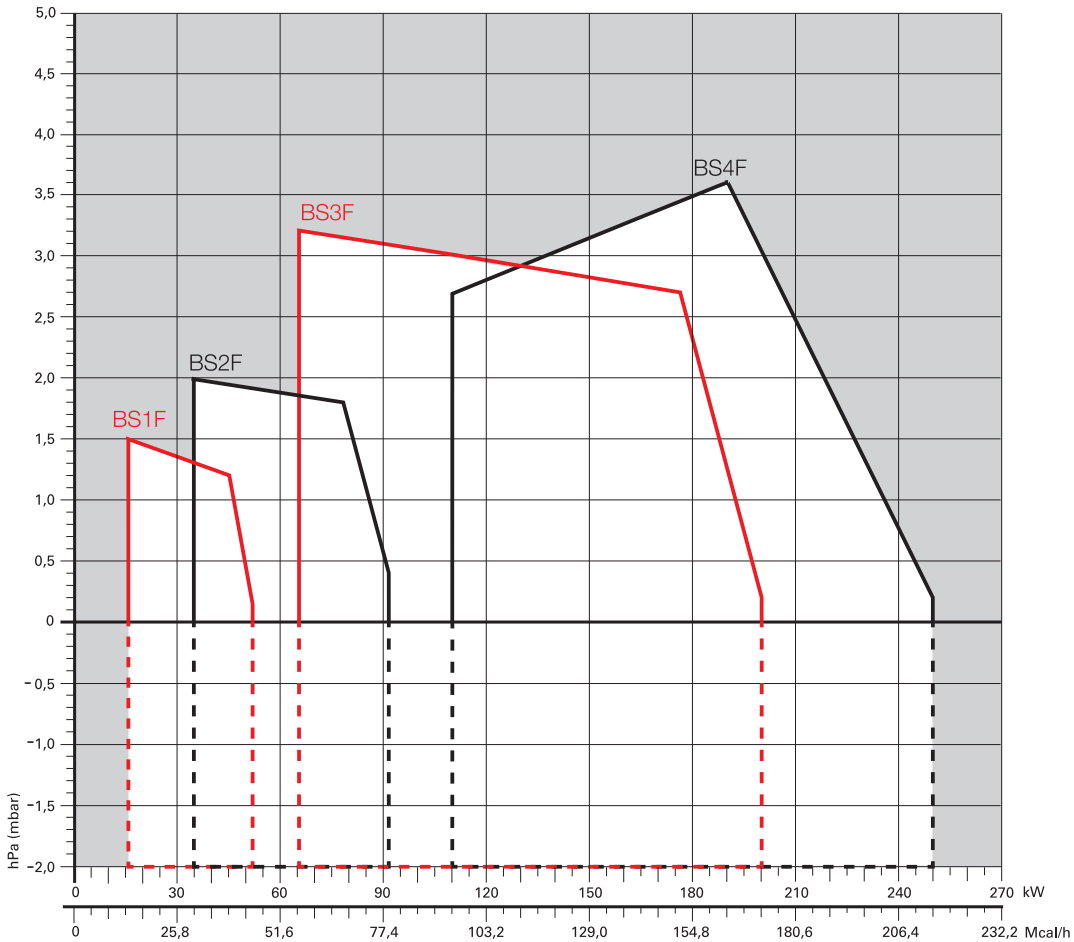

Useful working field for choosing the burner

Test conditions conforming to EN676
 Temperature: 20°C
 Pressure: 1013,5 mbar
 Altitude: 0 m a.s.l.

IMPORTANT:
 For the part of the working field that is depressurised, refer to EN 746-2 Standard.

Overall dimensions (mm)

BURNER

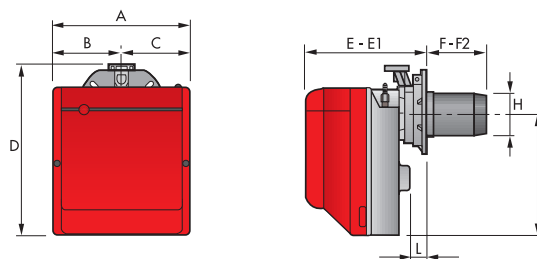

MODEL	A	B	C	D	E	E1	F	F2	H	I	L
▶ BS1F	234	122	112	295	230	276	116	70	89	210	41
▶ BS2F	255	125,5	125,5	325	238	252	114	100	106	230	45
▶ BS3F	300	150	150	391	262	280	128	110	129	285	45
▶ BS4F	300	150	150	392	278	301	168	145	137	286	45

Overall dimensions (mm)

BURNER - BOILER MOUNTING FLANGE

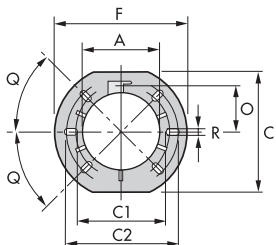

MODEL	A	C	C1	C2	F	O	Q	R
▶ BS1F	89	167	140	170	192	66	45°	11
▶ BS2F	106	167	140	170	192	66	45°	11
▶ BS3F	129	201	160	190	216	76,5	45°	11
▶ BS4F	137	203	170	200	218	80,5	45°	11

PACKAGING

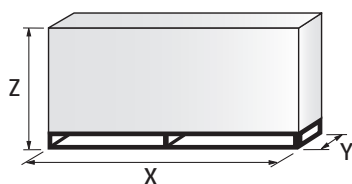

MODEL	X	Y	Z	kg
▶ BS1F	395	278	350	10
▶ BS2F	405	298	375	11
▶ BS3F	450	345	440	15
▶ BS4F	510	345	440	16,5

Specification

DESIGNATION OF SERIES

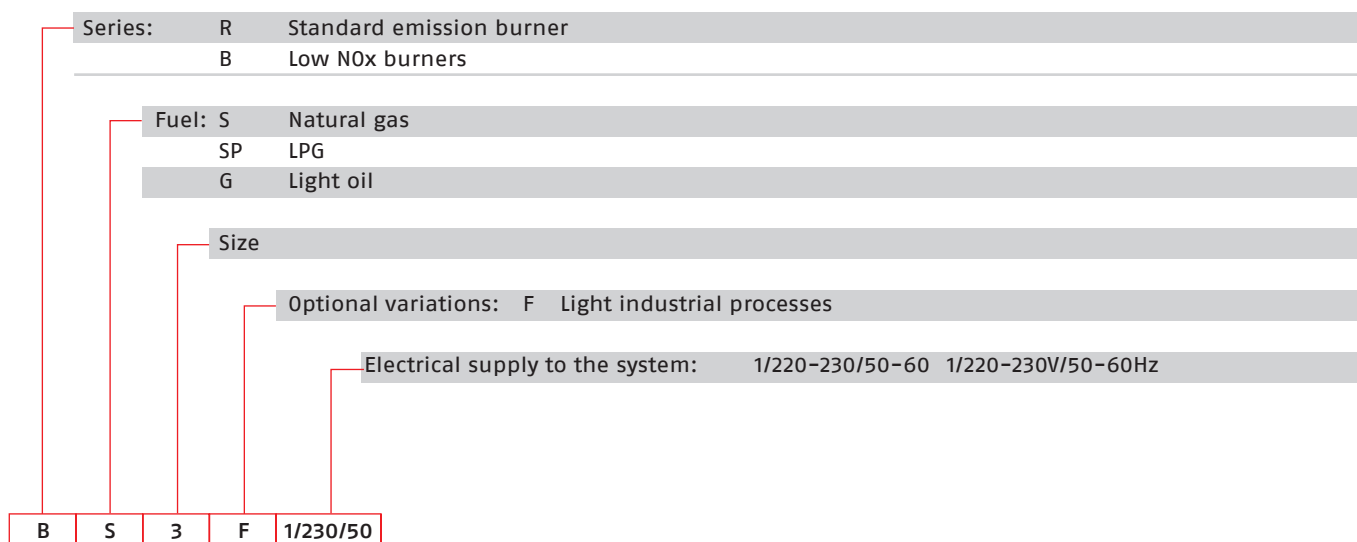

Gas Oven Burners

GULLIVER BSF SERIES

STATE OF SUPPLY

Monobloc, gas burners, completely automatic, with one stage operation fitted with:

- Fan with forward curve blades
- Cover lined with sound-proofing material
- Air damper always open in stand by, with external adjustment, with no need to remove the cover
- Single phase electric motor 220 - 230 V/50 - 60 Hz
- Combustion head fitted with:
 - stainless steel head cone, resistant to high temperatures
 - ignition electrodes
 - ionisation probe
 - gas distributor
 - flame stability disk
- Flame inspection window
- Adjustable air pressure switch, with graduated selector, to guarantee burner lock out in the case of insufficient combustible air
- Microprocessor-based burner safety control box, with diagnostic and remote reset functions
- Protection filter against radio interference (included into burner safety control box)
- IP X0D (IP 40) electric protection level.

Standard equipment:

- Flange with insulating gasket
- Screw and nut for flange
- Screw and nuts for flange to be fixed to the heat generator
- 7-pin plug
- Remote control release kit
- Instruction handbook for installation, use and maintenance
- Spare parts catalogue.

Available models

Burners

CODE	MODEL	HEAT OUTPUT		TOTAL ELECTRICAL POWER (kW)	CERTIFICATION	NOTE
		(kW)	NATURAL GAS (Nm ³ /h)			
3761171	BS1F 1/220-230/50-60	16 - 52	1,6 - 5,2	0,135 (at 50Hz) - 0,165 (at 60 Hz)	CE - 0085 AQ0409	(1)
3761271	BS2F 1/220-230/50-60	35 - 92	3,5 - 9,1	0,155 (at 50Hz) - 0,200 (at 60 Hz)	CE - 0085 AQ0409	(1)
3761371	BS3F 1/220-230/50-60	65 - 197	6,5 - 20	0,355 (at 50Hz) - 0,485 (at 60 Hz)	CE - 0085 AQ0409	(1)
3761471	BS4F 1/220-230/50-60	110 - 246	11,0 - 25	0,420 (at 50Hz) - 0,600 (at 60 Hz)	CE - 0085 AQ0409	(1)

Net calorific value G20: 10 kWh/Nm³ - Density: 0,71 kg/Nm³.

The burners of BSF series are in according to EN 676.

(1) With plug and socket.

Gas Trains

GAS TRAIN CODE *	GAS TRAIN MODEL	NATURAL GAS		LPG		NOTE
		BURNER (type)	ADAPTER (code)	BURNER (type)	ADAPTER (code)	
MULTIBLOC	3970570	MBC 65/1 - F1SD 20	BS1F		BS1F	(1)
	3970546	MB 405/1 - F1SD 20	BS1F		BS1F	(1)
	3970547	MB 405/1 - F2SD 20	BS2F		BS2F	(1)
	3970544	MB 407/1 - F2SD 20	BS2F		BS2F	(1)
	3970548	MB 407/1 - F3SD 20	BS3F - BS4F		BS3F - BS4F	(1)
	3970549	MB 410/1 - F3SD 20	BS3F - BS4F		BS3F - BS4F	(1)
	3970550	MB 412/1 - F3SD 20	BS3F - BS4F		BS3F - BS4F	(1)

Please see Designation of Gas Train Series in the page before the Catalogue index.

* Gas trains are 230V/50Hz - 220V/60Hz electrical supply.

(1) With installed plug.

The valve seal control device is compulsory (conforming to EN 676) on gas trains to burners with a maximum output over 1200 kW.

To select the gas train please refer to the technical data leaflet and/or instruction manual.

Burner accessories

Extended head kit

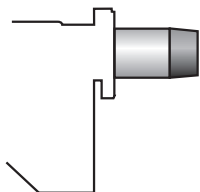

Burners standard head can be transformed into "extended head" versions by using the special kit. Here the kits available for the various burners are listed, showing the original and the extended lengths.

BURNER	STANDARD HEAD LENGTH (mm)	EXTENDED HEAD LENGTH (mm)	KIT CODE
▶ BS2F (long)	100 ÷ 114	170 ÷ 180	3001007
▶ BS2F (extra long)	100 ÷ 114	270 ÷ 280	3001008
▶ BS3F	110 ÷ 128	267 ÷ 282	3001009
▶ BS4F	145 ÷ 168	302 ÷ 317	3001016

Alternative combustion head kit

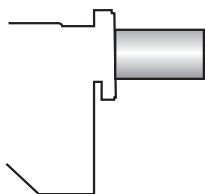

This kit can be used to prevent combustion instability which could arise with particular heat generators.

To extend the adaptability of Gulliver BSF burners to any sort of application, alternative combustion heads have been developed.

These heads cause a very limited increase in NOx emissions, due to the slower air flow.

BURNER	KIT CODE (*)
▶ BS1F	3001059
▶ BS2F	3001064
▶ BS3F	3001060
▶ BS4F	3001070

(*) CE approval on field is required

LPG kit



For burning LPG gas, a special kit is available to be fitted to the combustion head on the burner, as shown in the following table.

BURNER	KIT CODE FOR STANDARD HEAD	KIT CODE FOR EXTENDED HEAD
▶ BS1F	3001003	3001003
▶ BS2F	3001004	3001004
▶ BS3F	3001005	3001005
▶ BS4F	3001011	3001011

Town Gas kit



For burning Town Gas, a special kit is available to be fitted to the combustion head on the burner, as shown in the following table.

BURNER	KIT CODE FOR STANDARD HEAD (*)	KIT CODE FOR EXTENDED HEAD (*)
▶ BS1F	3002727	-
▶ BS2F	3002728	3002728
▶ BS3F	3002729	3002729

(*) Without CE certification

Gas Oven Burners

GULLIVER BSF SERIES

Burner accessories

Ground fault interrupter kit



A "ground fault interrupter kit" is available as safety device in case of electrical system fault.

BURNER	KIT CODE
► BS1F - BS2F - BS3F - BS4F	3001180

Multibloc rotation kit

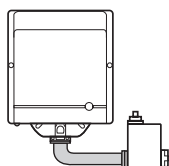

There is a special kit available that can be used to install the burner turned 180°. This kit is designed to ensure the gas train valve properly.

BURNER	KIT CODE
► BS1F	3001179
► BS2F	3001177
► BS3F - BS4F	3001178

7-pin plug kit

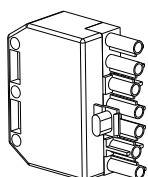

If necessary a 7-pin plug kit is available (in packaging of n. 5 pieces).

BURNER	KIT CODE
► All models	3000945

Gas train accessories

Seal control kit



To test the valve seals on the gas train, (except for the model with Multibloc MBC 65 DLE) a special "seal control kit" is available.

GAS TRAIN	KIT CODE for 50 Hz operation	KIT CODE for 60 Hz operation
► MB/1 type	3010123	20168805

GULLIVER BSDF SERIES

The Riello Gulliver BSDF series of two stage gas burners, is a complete range of Low NOx emission products, developed to respond to any request for light industrial processes like bakery ovens, spray painting ovens, small steam or thermal boilers and all applications which require a reliable, user-friendly industrial product with enhanced performance and specific functions.

This series of burners is available in two different models with an output ranging from 75 to 246 kW, divided in two different structures.

All the models use the same components designed by Riello for the Gulliver series. The high quality level guarantees safe working. The burners are fitted with a microprocessor-based burner safety control box which supplies indication of operation and diagnosis of fault cause.

This new series can operate on 50 or 60 Hz and a Voltage 220 - 230 Volt (dual frequency).

For depressurised working field see EN 746-2 Standard.

All the Gulliver BSD burners are tested before leaving the factory.

Guidelines for installation of burners in conformity to EU Regulation:

A RIELLO burner (Heat Generator), where it is matched with a water-based boiler (Heater Housing) with a nominal output ≤ 400 kW, providing heat for heating purposes and heat to deliver sanitary hot water, can be installed:

- With boilers (heater housings) already in service in the field, for replacement of identical products, in conformity to Article 1, paragraph 2, point (G) of the EU Regulation No. 813/2013;
- With boilers (heater housings) on a new installation.

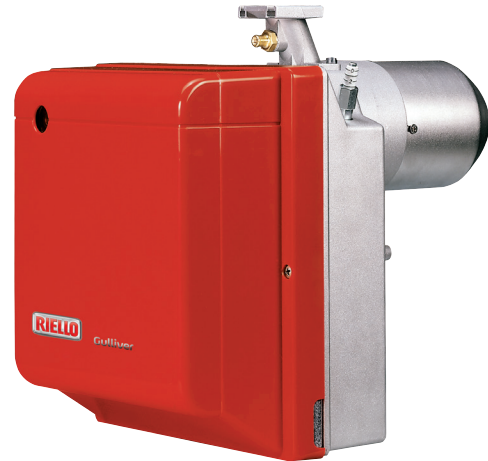

BS3DF	65/80	÷	197	kW
BS4DF	110/140	÷	249	kW

PROCESS
BURNERS

FIRING RATES

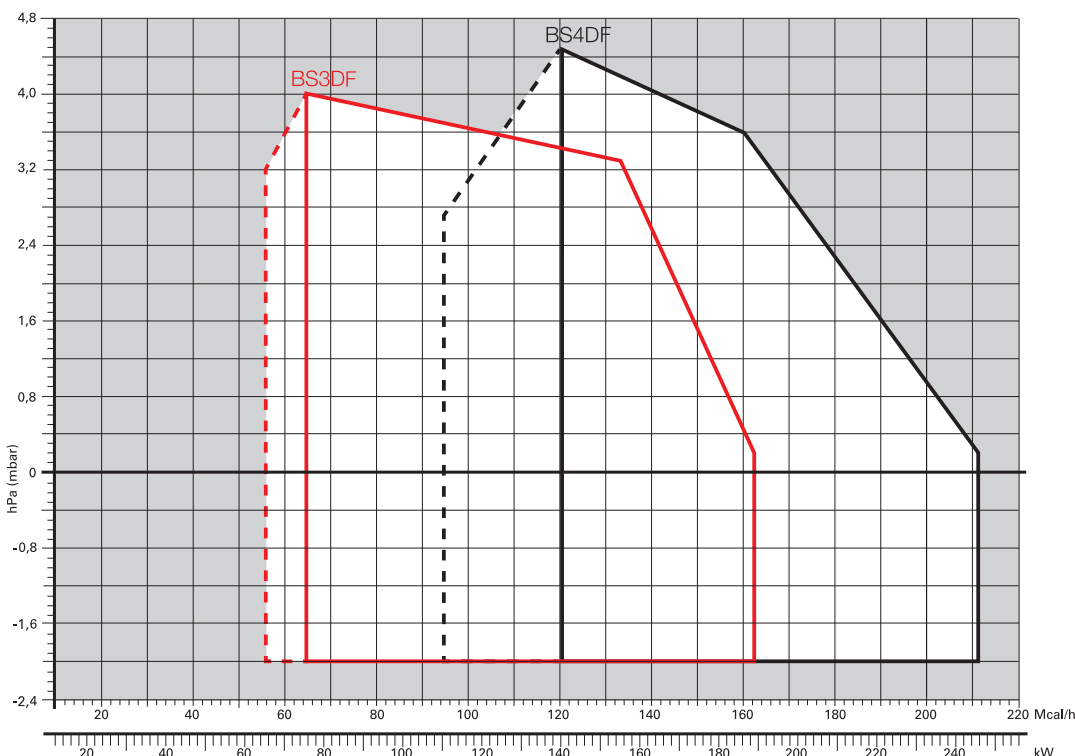

Useful working field for choosing the burner

1st stage operation range

Test conditions conforming to EN676
Temperature: 20°C
Pressure: 1013,5 mbar
Altitude: 0 m a.s.l.

Gas Oven Burners

GULLIVER BSDF SERIES

Overall dimensions (mm)

BURNER

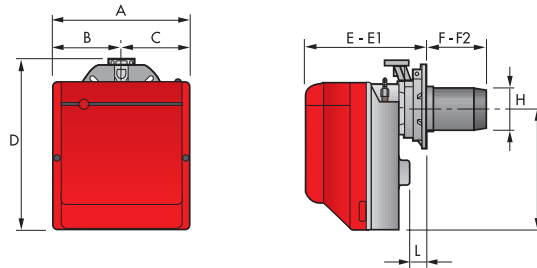

MODEL	A	B	C	D	E	E1	F	F2	H	I	L
► BS3DF	300	150	150	391	262	280	128	110	129	285	45
► BS4DF	300	150	150	392	278	301	168	145	137	286	45

BURNER - BOILER MOUNTING FLANGE

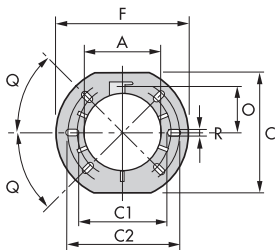

MODEL	A	C	C1	C2	F	O	Q	R
► BS3DF	129	201	160	190	216	76,5	45°	11
► BS4DF	137	203	170	200	218	80,5	45°	11

PACKAGING

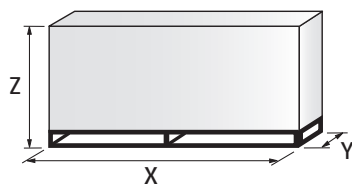

MODEL	X	Y	Z	kg
► BS3DF	450	345	440	16
► BS4DF	510	345	440	18

GULLIVER BSDF SERIES

Specification

DESIGNATION OF SERIES

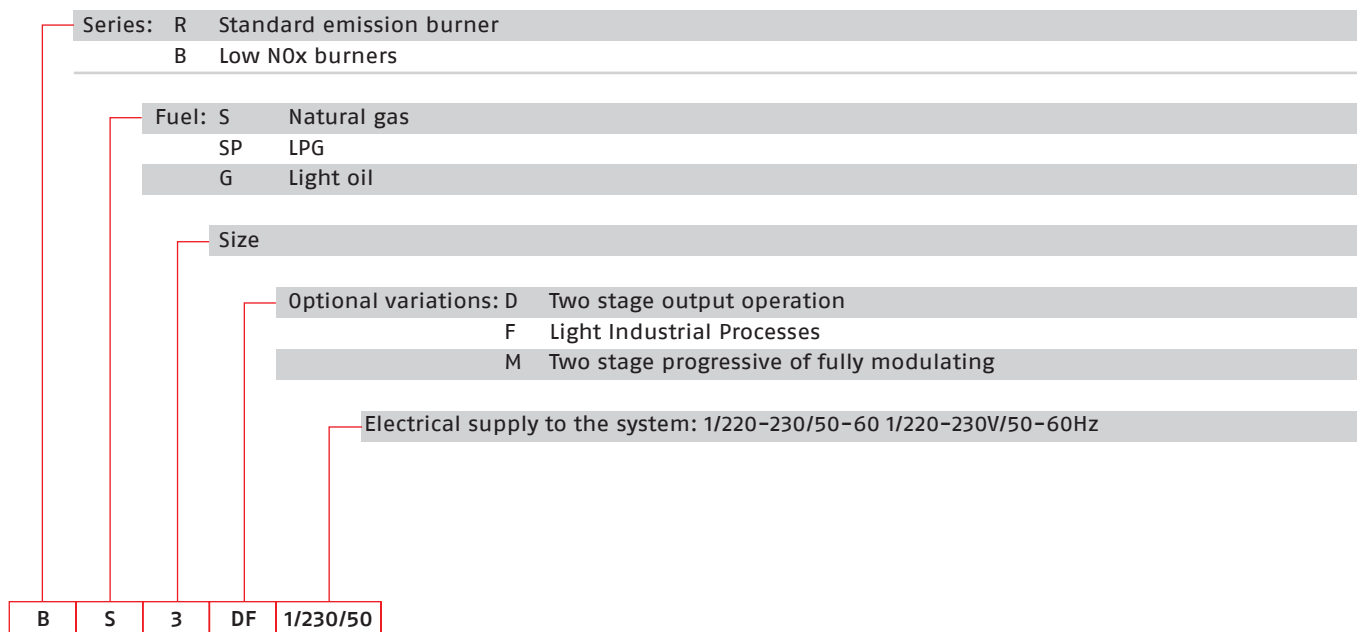

STATE OF SUPPLY

Monoblock, gas burners, completely automatic, two stage operation, made up of:

- Fan with forward curve blades
- Cover lined with sound-proofing material
- Air damper with 1st and 2nd stage adjustment (2nd stage external adjustment, with no need to remove the cover)
- Driven by an electric servomotor
- Single phase electric motor 220-230 V / 50-60 Hz
- Combustion head fitted with:
 - stainless steel head cone, resistant to high temperatures
 - ignition electrodes
 - ionisation probe
 - gas distributor
 - flame stability disk
- Flame inspection window
- Adjustable air pressure switch, with graduated selector, to guarantee burner lock out in the case of insufficient combustible air
- Microprocessor-based burner safety control box, with diagnostic and remote reset functions
- Protection filter against radio interference (included into burner safety control box)
- IP X0D (IP 40) electric protection level.

Standard equipment:

- Sliding flange
- Flange insulation screen
- Screws and nuts for fixing the flange to the boiler
- 7-pin plug
- 4-pin plug
- Remote control release kit
- Instruction handbook for installation, use and maintenance
- Spare parts catalogue.

Gas Oven Burners

GULLIVER BSDF SERIES

Available models

Burners

CODE	MODEL	HEAT OUTPUT		TOTAL ELECTRICAL POWER (kW)	CERTIFICATION	NOTE
		(kW)	NATURAL GAS (Nm ³ /h)			
3761391	BS3DF 1/220-230/50-60	65/80 - 197	6,5/7,5 - 19	0,355 (at 50Hz) 0,485 (at 60 Hz)		(1)
3761491	BS4DF 1/220-230/50-60	110/140 - 249	11/14 - 24,6	0,420 (at 50Hz) 0,600 (at 60 Hz)		(1)

Net calorific value G20: 10 kWh/Nm³ - Density: 0,71 kg/Nm³.
 Net calorific value LPG: 25,8 kWh/Nm³ - Density: 2,02 kg/Nm³.
 The burners of BS series are in according to EN 676.
 (1) With plug and socket.

Gas Trains

	GAS TRAIN	GAS TRAIN	NATURAL GAS		LPG		NOTE
	CODE *	MODEL	BURNER (type)	ADAPTER (code)	BURNER (type)	ADAPTER (code)	
MULTIBLOC	3970541	MB 407/2 - F3SD 20	BS3DF - BS4DF		BS3DF - BS4DF		(1)
	3970542	MB 410/2 - F3SD 20	BS3DF - BS4DF		BS3DF - BS4DF		
	3970543	MB 412/2 - F3SD 20	BS3DF - BS4DF		BS3DF - BS4DF		

Please see Designation of Gas Train Series in the page before the Catalogue index.

* Gas trains are 230V/50Hz - 220V/60Hz electrical supply.

(1) With installed plug.

The valve seal control device is compulsory (conforming to EN 676) on gas trains to burners with a maximum output over 1200 kW.

To select the gas train please refer to the technical data leaflet and/or instruction manual.

Burner accessories

Extended head kit

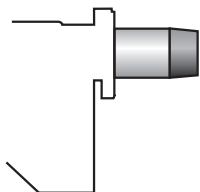

Burners standard head can be transformed into "extended head" versions by using the special kit.
 Here the KITS available for the various burners are listed, showing the original and the extended lengths.

BURNER	STANDARD HEAD LENGTH (mm)	EXTENDED HEAD LENGTH (mm)	KIT CODE
▶ BS3DF	110 ÷ 128	267 ÷ 282	3001009
▶ BS4DF	145 ÷ 168	302 ÷ 317	3001016

Alternative combustion head kit

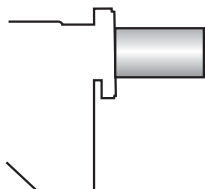

This kit can be used to prevent combustion instability which could arise with particular heat generators.
 To extend the adaptability of Gulliver BSDF burners to any sort of application, alternative combustion heads have been developed.
 These heads cause a very limited increase in NOx emissions, due to the slower air flow.

BURNER	KIT CODE
▶ BS3DF	3001060
▶ BS4DF	3001070

LPG kit



For burning LPG gas, a special kit is available to be fitted to the combustion head on the burner, as shown in the following table.

BURNER	KIT CODE FOR STANDARD HEAD	KIT CODE FOR EXTENDED HEAD
▶ BS3DF	3001005	3001005
▶ BS4DF	3001011	3001011

Town Gas kit



For burning Town Gas, a special kit is available to be fitted to the combustion head on the burner, as shown in the following table.

BURNER	KIT CODE FOR STANDARD HEAD (*)	KIT CODE FOR EXTENDED HEAD (*)
▶ BS3DF	3002729	3002729

(*) Without CE certification

Ground fault interrupter kit



A "Ground fault interrupter kit" is available as a safety device in case of electrical system fault.
 It is supplied with burners with pin plug.

BURNER	KIT CODE
▶ BS3DF - BS4DF	3001180

Gas Oven Burners

GULLIVER BSDF SERIES

Burner accessories

Multibloc rotation kit

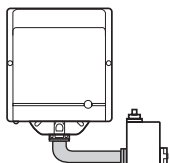

There is a special kit available that can be used to install the burner turned 180°. This kit is designed to ensure the gas train valve properly.

BURNER	KIT CODE
► BS3DF - BS4DF	3001178

7-pin plug kit

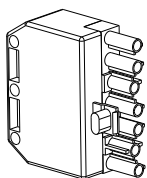

If necessary a 7-pin plug kit is available (in packaging of n. 5 pieces).

BURNER	KIT CODE
► BS3DF - BS4DF	3000945

Gas train accessories

Seal control kit



To test the valve seals on the gas train a special "seal control kit" is available.

GAS TRAIN	KIT CODE for 50 Hz operation	KIT CODE for 60 Hz operation
► MB/1 type	3010123	20168805

RIELLO 40 FS SERIES

The Riello 40 FS series of one stage gas burners, is a complete range of products developed to respond to any request for light industrial application. The Riello 40 FS series is available in five different models, with an output ranging from 11 to 220 kW, divided in four different structures.

All the models use the same components designed by Riello for the Riello 40 FS series. The high quality level guarantees safe working.

The Riello 40 FS burners are fitted with a microprocessor - based control box, with diagnostic functions.

In developing these burners, special attention was paid to reducing noise, to the ease of installation and adjustment, to obtaining the smallest size possible to fit into any sort of boiler available on the market.

All the models are approved by the EN 676 European Standard and conform to European Directives for EMC, Low Voltage, Machinery and Boiler Efficiency.

All the Riello 40 FS burners are tested before leaving the factory.

FS3	11 ÷	35 kW
FS5	23 ÷	58 kW
FS8	46 ÷	93 kW
FS10	42 ÷	116 kW
FS15	81 ÷	175 kW
FS20	81 ÷	220 kW

FIRING RATES

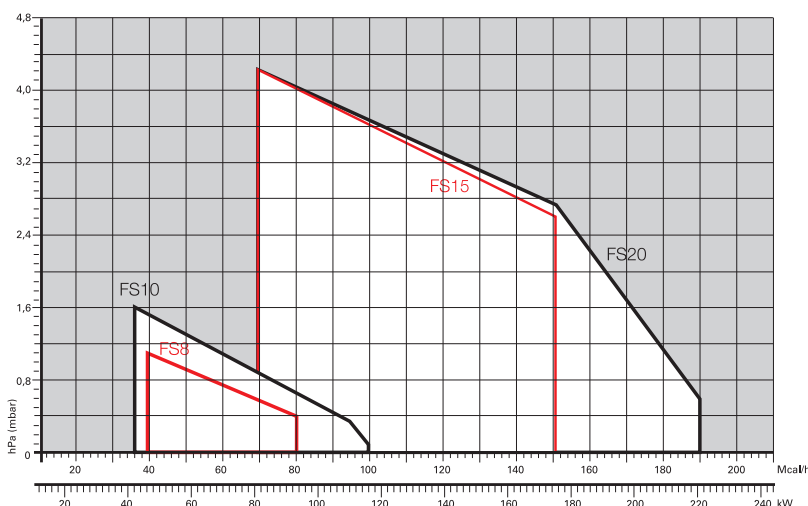
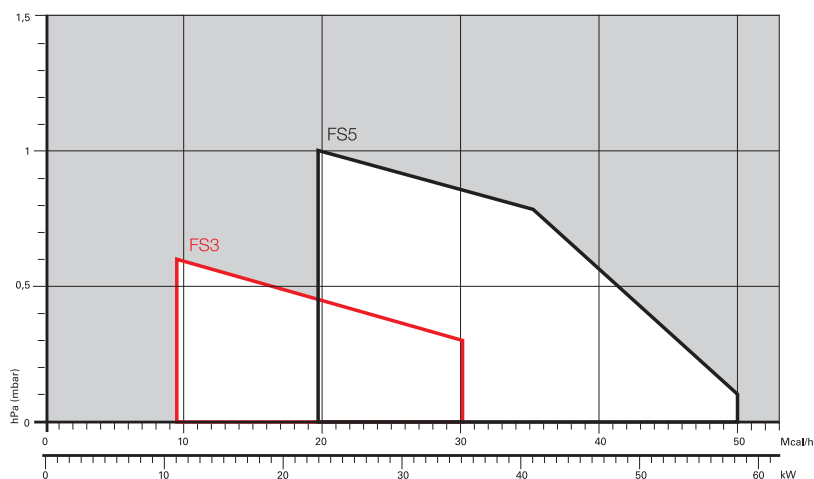

Guidelines for installation of burners in conformity to EU Regulation:

A RIELLO burner (Heat Generator), where it is matched with a water-based boiler (Heater Housing) with a nominal output ≤ 400 kW, providing heat for heating purposes and heat to deliver sanitary hot water, can be installed:

- With boilers (heater housings) already in service in the field, for replacement of identical products, in conformity to Article 1, paragraph 2, point (G) of the EU Regulation No. 813/2013;
- With boilers (heater housings) on a new installation.



Useful working field for choosing the burner

Test conditions conforming to EN676
 Temperature: 20°C
 Pressure: 1013,5 mbar
 Altitude: 0 m a.s.l.

Gas Oven Burners

RIELLO 40 FS SERIES

Overall dimensions (mm)

BURNER

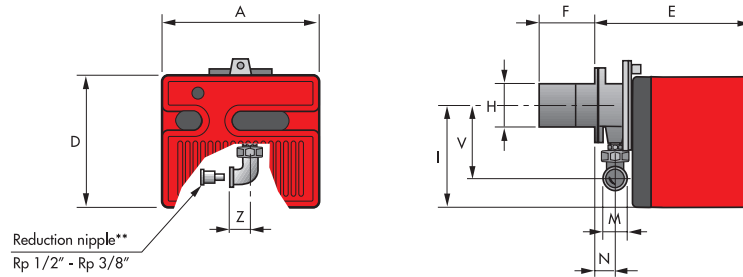

MODEL	A	D	E	F	H	I	M	N	V	Z
▶ FS3	252	215	230	100	91	165	Rp 3/8"*	37	132	25
▶ FS5	272	233	295	100	91	180	Rp 1/2"	48	138	28
▶ FS8	305	262	347	110	105	204	Rp 3/4"	61	142	33
▶ FS10	305	262	346	110	105	204	Rp 3/4"	61	142	33
▶ FS15	350	298	389	120	125	230	Rp 3/4"	67	152	33
▶ FS20	350	298	389	120	125	230	Rp 3/4"	67	152	33

* With reduction nipple
** Standard equipment on R40 FS3

BURNER - BOILER MOUNTING FLANGE

FS3 - FS5 - FS8 - FS10

FS15 - FS20

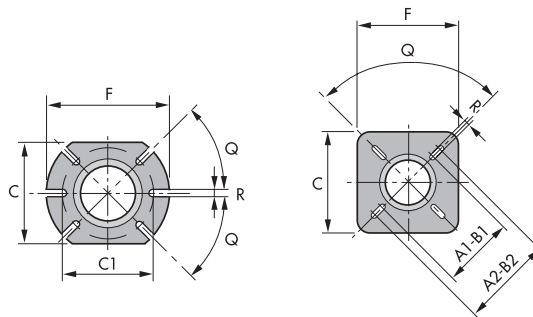

MODEL	A1	A2	B1	B2	C	C1	F	Q	R
▶ FS3	-	-	-	-	140	130	170	45°	10
▶ FS5	-	-	-	-	140	130	170	45°	10
▶ FS8	-	-	-	-	160	130	185	45°	11
▶ FS10	-	-	-	-	160	130	185	45°	11
▶ FS15	155	200	155	200	170	-	170	90°	11
▶ FS20	155	200	155	200	170	-	170	90°	11

PACKAGING

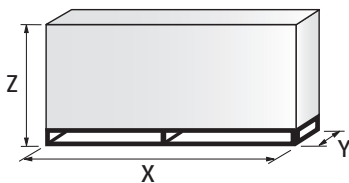

MODEL	X	Y	Z	kg
▶ FS3	375	335	310	9,5
▶ FS5	445	355	335	11
▶ FS8	483	495	330	13
▶ FS10	483	495	330	16
▶ FS15	535	535	375	19
▶ FS20	535	535	375	20

Specification

DESIGNATION OF SERIES

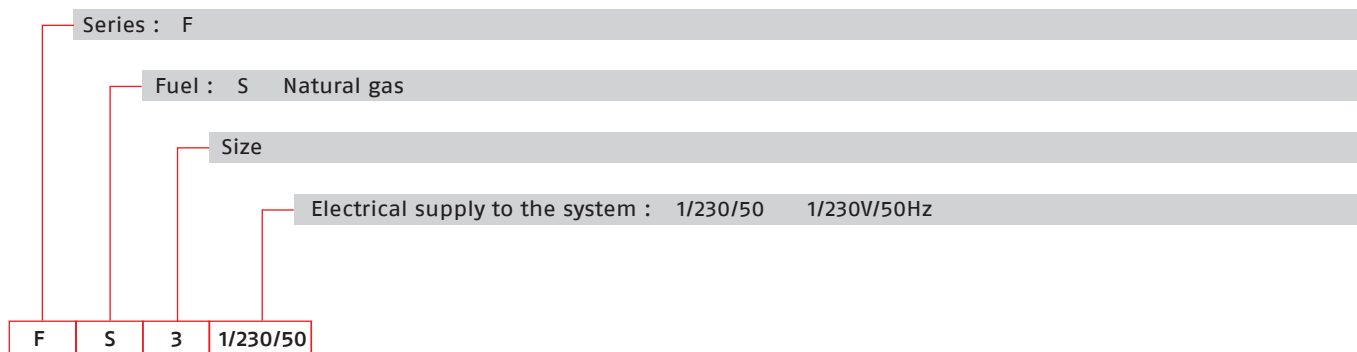

STATE OF SUPPLY

Monoblock, gas burners, completely automatic, with one stage settings fitted with:

- Fan with forward curve blades
- Cover lined with sound-deadening material
- Metallic and fixed air damper with adjustment
- Single phase electric motor 230 V, 50 Hz
- Combustion head fitted with:
 - stainless steel head cone, resistant to high temperatures
 - ignition electrodes
 - ionisation probe
 - gas distributor
 - flame stability disk
 - flame inspection window
- Adjustable air pressure switch, with graduated selector, to guarantee burner lock out in the case of insufficient combustible air
- Microprocessor-based flame control box, with diagnostic functions
- IP X0D (IP 40) electric protection level.

Standard equipment:

- Flange insulation screen
- Screws and nuts for fixing the flange to the boiler
- 7-pole socket
- Hinge
- Reduction nipple Rp 1/2" - Rp 3/8" (for R40 FS3 only)
- Grommet
- Instruction handbook for installation, use and maintenance
- Spare parts catalogue.

Gas Oven Burners

RIELLO 40 FS SERIES

Available models

Burners

CODE	MODEL		HEAT OUTPUT		TOTAL ELECTRICAL POWER (kW)	CERTIFICATION	NOTE
			NATURAL GAS				
			(kW)	(Nm ³ /h)			
3756506	FS3	1/230/50	11 - 35	1,1 - 3,5	0,150	CE-0476CT2714	(1)
3756606	FS5	1/230/50	23 - 58	2,3 - 5,8	0,150	CE-0476CT2714	(1)
3756706	FS8	1/230/50	46 - 93	4,6 - 9,3	0,150	CE-0476CT2714	(1)
3756435	FS10	1/230/50	42 - 116	4,2 - 11,6	0,130	CE-0476CT2714	(1) (2)
3756803	FS15	1/230/50	81 - 175	8,1 - 17,5	0,130	CE-0476CT2714	(2)
3756935	FS20	1/230/50	81 - 220	8,1 - 22	0,250	CE-0476CT2714	(1) (2)

Models for LPG applications

CODE	MODEL		HEAT OUTPUT		TOTAL ELECTRICAL POWER (kW)	CERTIFICATION	NOTE
			LPG				
			(kW)	(Nm ³ /h)			
3756439	FSP10	1/230/50	42 - 116	1,6 - 4,4	0,130	CE - 0063AP6680	(1) (2)
3756939	FSP20	1/230/50	81 - 220	3,1 - 8,5	0,250	CE - 0063AP6680	(1) (2)

Net calorific value G20: 10 kWh/Nm³ - Density: 0,71 kg/Nm³

Net calorific value G31 (LPG): 25,8 kWh/Nm³ - Density: 2,02 kg/Nm³

The burners of FS series are in accordance with EN 676

(1) With plug and socket

(2) French version

Gas Trains

	GAS TRAIN	GAS TRAIN	NATURAL GAS		LPG		NOTE
	CODE *	MODEL	BURNER (type)	ADAPTER (code)	BURNER (type)	ADAPTER (code)	
MULTIBLOC GAS TRAIN	3970569	MBC 65/1 - RSD 20	FS3 - FS5		FS3 - FS5		(1)
	3970530	MB 405/1 - RSD 20	FS5 - FS8 - FS20		FS5 - FS8 - FS20		(1) (2)
	3970531	MB 407/1 - RSD 20	FS5 - FS8 - FS10 - FS20		FS5 - FS8 - FS10 FS15 - FS20		(1) (4)
	3970532	MB 410/1 - RSD 20	FS10 - FS20		FS10 - FS20		(1)
	3970553	MB 407/1 - RT20	FS15		FS15		(1)

Please see Designation of Gas Train Series in the page before the Catalogue index.

* Gas train are 230V/50Hz - 220V/60Hz electrical supply

(1) With installed plug (if the plug is not necessary, remove it in accordance with gas train instruction manual indication)

(2) FS8 ≤ 80 kW with natural gas

(3) FS10 ≤ 80 kW with natural gas

(4) FS20 ≤ 180 kW with natural gas

The valve seal control device is compulsory (conforming to EN 676) on gas trains to burners with a maximum output over 1200 kW.

To select the gas train please refer to the technical data leaflet and/or instruction manual.

Burner accessories

Remote reset control kit for MG 557/3/5 control box

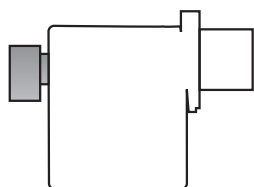

The MG 557 control box can be remotely released using an electric command kit. This kit must be installed in conformity with the local authority.

BURNER	KIT CODE
▶ FS3 – FS5 – FS8 – FS15	3002750

Extended head kit

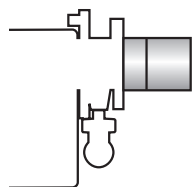

Burners “standard head” can be transformed into “extended head” versions by using the special kit. Here the KITS available for the various burners are listed, showing the original and the extended lengths.

BURNER	STANDARD HEAD LENGTH (mm)	EXTENDED HEAD LENGTH (mm)	KIT CODE
▶ FS3 – FS5	100	125	3000820
▶ FS8 – FS10	110	170	3001064
▶ FS8	110	278	3000920
▶ FS15 – FS20	120	280	3000873

End cone with turbulator disk



The end cone turbulator disk reduces the flame length. It is suitable for oven application (CO emissions) and short boiler chamber.

BURNER	PROJECTION (mm)	KIT CODE
▶ FS5	+15	3000916
▶ FS8	+18	3000917
▶ FS10	+18	3000918
▶ FS20	+23	3000919

LPG kit

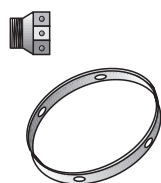

For burning LPG gas, a special kit is available to be fitted to the combustion head on the burner as shown in the following table.

BURNER	KIT CODE FOR STANDARD HEAD	KIT CODE FOR EXTENDED HEAD
▶ FS3	3000881	3000881
▶ FS5	3000882	3000882
▶ FS8	3000927	3000927
▶ FS10	3000884	3000884
▶ FS15	3000885	3000885
▶ FS20	3000886	3000886

Gas Oven Burners

RIELLO 40 FS SERIES

Burner accessories

Inlet air aspiration kit

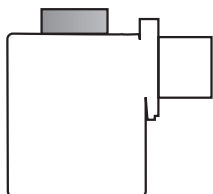

This kit allows to channel the external air directly into the burner and is available as accessory for models:

BURNER	KIT CODE
▶ FS3	20027571
▶ FS5	20027576
▶ FS8	20027578
▶ FS10	20159837
▶ FS15 - FS20	20159751

Town gas kit

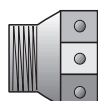

BURNER	KIT CODE
▶ FS3	3000888
▶ FS5	3000889
▶ FS8	3000890
▶ FS10	3000891
▶ FS20	3000893

Ground fault interrupter kit



A "Ground fault interrupter kit" is available as a safety device in case of electrical system fault. It is supplied with burners with pin plug.

BURNER	KIT CODE
▶ FS5 - FS8 - FS10 - FS20	3001180

7-pin plug kit

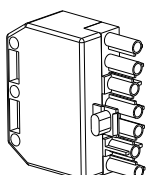

If necessary a 7-pin plug kit is available (in packaging of n. 5 pieces).

BURNER	KIT CODE
▶ All models	3000945

Continuous ventilation kit for RMG control box

If the burner requires continuous ventilation in the stages without flame, a special kit is available as given in the following table.

BURNER	KIT CODE
▶ FS15 - FS10 - FS20	3010094

Burner accessories

PC interface kit



To connect the control box to a personal computer for the transmission of operation, fault signals and detailed service information, an interface adapter with PC software are available.

BURNER	KIT CODE
► FS10 - FS15 - FS20	3002719

Gas train accessories

Seal control kit



To test the valve seals on the gas train, (except for the model with Multibloc MBC 65 DLE) a special "seal control kit" is available.

GAS TRAIN	KIT CODE for 50 Hz operation	KIT CODE for 60 Hz operation
► MB/1 type	3010123	20168805



We are here
bringing warmth in your life



RIELLO 40 FSD SERIES

The Riello 40 FSD series of two stage gas burners, is a complete range of products developed to respond to any request for light industrial process. The Riello 40 FSD series is available in two different models, with an output ranging from 12 to 220 kW, divided in two different structures.

All the models use the same components designed by Riello for the Riello 40 FSD series. The high quality level guarantees safe working.

The Riello 40 FSD burners are fitted with a microprocessor – based control box, with diagnostic functions.

In developing these burners, special attention was paid to reducing noise, to the ease of installation and adjustment, to obtaining the smallest size possible to fit into any sort of boiler available on the market.

All the models are approved by the EN 676 European Standard and conform to European Directives for EMC, Low Voltage, Machinery and Boiler Efficiency. All the Riello 40 FSD burners are tested before leaving the factory.

Guidelines for installation of burners in conformity to EU Regulation:

A RIELLO burner (Heat Generator), where it is matched with a water-based boiler (Heater Housing) with a nominal output ≤ 400 kW, providing heat for heating purposes and heat to deliver sanitary hot water, can be installed:

- With boilers (heater housings) already in service in the field, for replacement of identical products, in conformity to Article 1, paragraph 2, point (G) of the EU Regulation No. 813/2013;
- With boilers (heater housings) on a new installation.



FS5D	12/23 ÷	58 kW
FS20D	58/81 ÷	220 kW

Gas Oven Burners

RIELLO 40 FSD SERIES

FIRING RATES

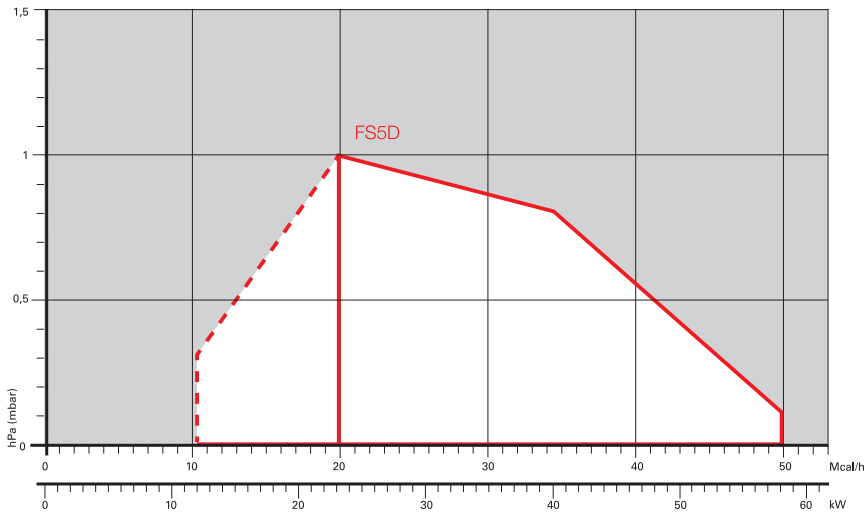

□ Useful working field for choosing the burner

▤ 1st stage operation range

Test conditions conforming to EN676
 Temperature: 20°C
 Pressure: 1013,5 mbar
 Altitude: 0 m a.s.l.

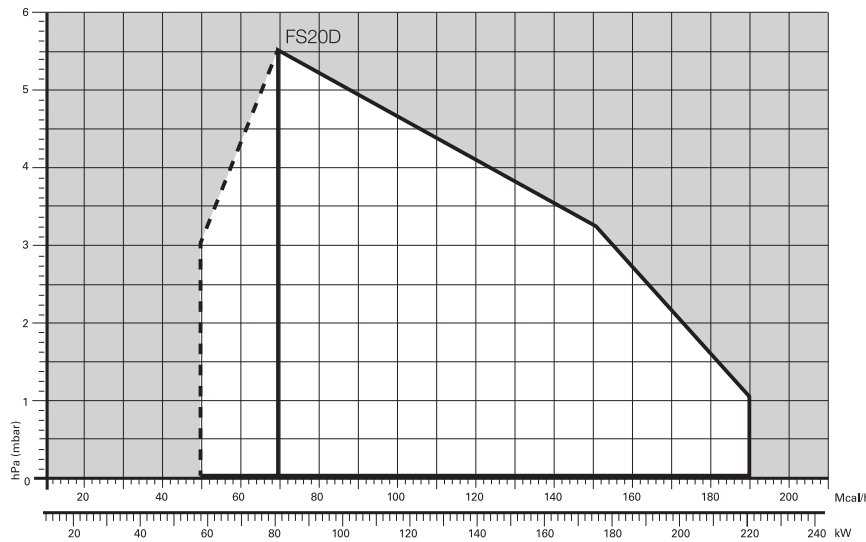

Overall dimensions (mm)

BURNER

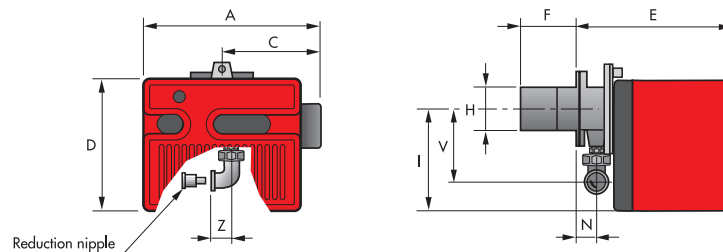

MODEL	A	C	D	E	F	H	I	N	V	Z
▶ FS5D	306	170	233	295	100	91	180	48	138	28
▶ FS20D	413	238	298	389	120	125	230	67	152	33

BURNER - BOILER MOUNTING FLANGE

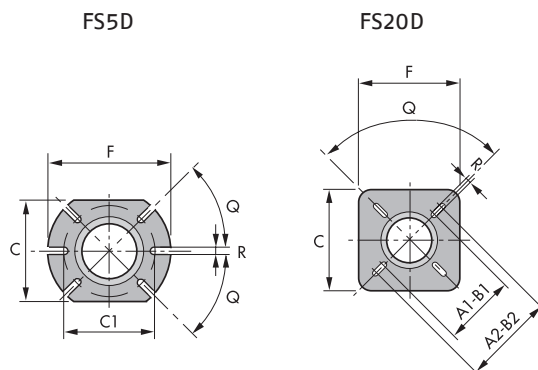

MODEL	A1	A2	B1	B2	C	C1	F	Q	R
▶ FS5D	-	-	-	-	140	130	170	45°	10
▶ FS20D	155	200	155	200	170	-	170	90°	11

PACKAGING

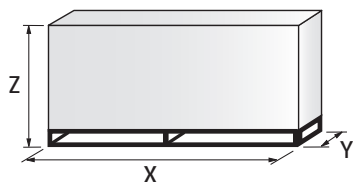

MODEL	X	Y	Z	kg
▶ FS5D	445	355	325	10
▶ FS20D	535	535	375	20

Specification

DESIGNATION OF SERIES

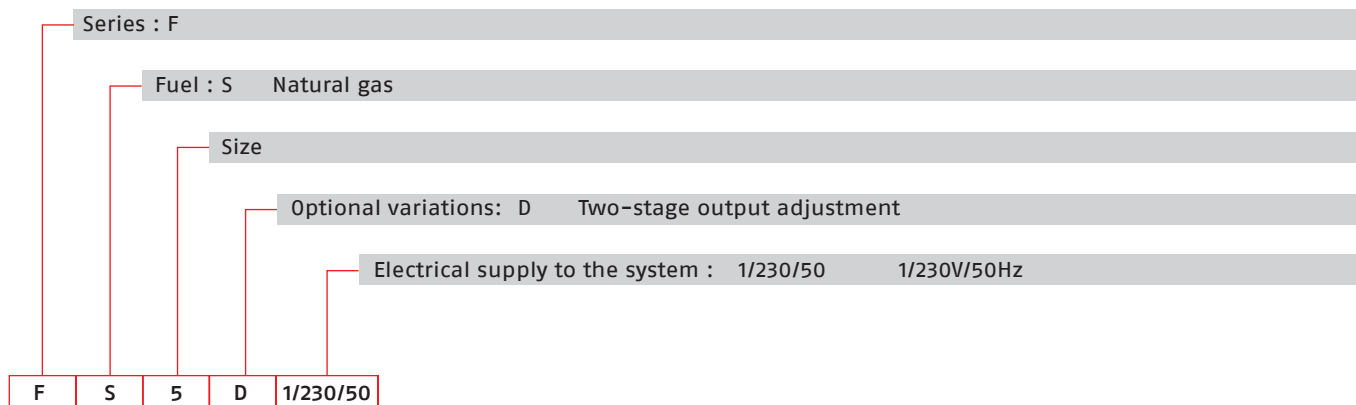

Gas Oven Burners

RIELLO 40 FSD SERIES

STATE OF SUPPLY

Monoblock, gas burners, completely automatic, with two stage settings fitted with:

- Fan with forward curve blades
- Metallic cover
- Air damper, open in stand by, driven by an electric servomotor
- Air damper with 1st and 2nd stage adjustment
- Single phase electric motor 230 V, 50 Hz
- Combustion head fitted with:
 - stainless steel head cone, resistant to high temperatures
 - ignition electrodes
 - ionisation probe
 - gas distributor
 - flame stability disk
- Adjustable air pressure switch, with graduated selector, to guarantee burner lock out in the case of insufficient combustible air
- Microprocessor-based burner safety control box MG 557 (with diagnostic, remote reset, continuous purge integrated, recycle, post-purge)
- IP X0D (IP 40) electric protection level.

Standard equipment:

- Insulating gasket
- Screws and nuts for fixing the flange to the boiler
- Hinge
- Cable grommet
- Instruction handbook for installation, use and maintenance
- Spare parts catalogue.

Available models

Burners

CODE	MODEL	HEAT OUTPUT		TOTAL ELECTRICAL POWER (kW)	CERTIFICATION	NOTE
		NATURAL GAS (kW)	(Nm ³ /h)			
3758705	FS5D 1/230/50	12/23 - 58	1,2/2,3 - 5,8	0,110	CE-0476CT2714	(1)
3759105	FS20D 1/230/50	58/81 - 220	5,8/8,1 - 22	0,250	CE-0476CT2714	(1)

Net calorific value G20: 10 kWh/Nm³ - Density: 0,71 kg/Nm³

The burners of FSD series are in according to EN 676

(1) With terminal block.

Gas Trains

	GAS TRAIN	GAS TRAIN	NATURAL GAS		LPG		NOTE
	CODE *	MODEL	BURNER (type)	ADAPTER (code)	BURNER (type)	ADAPTER (code)	
MULTIBLOC GAS TRAINS	3970084	MB 405/2 - RSD 20	FS5D		FS5D		(1)
	3970537	MB 407/2 - RSD 20	FS20D		FS20D		(1) (2)
	3970534	MB 410/2 - RSD 20	FS20D		FS20D		(1)

Please see Designation of Gas Train Series in the page before the Catalogue index.

* Gas train are 230V/50Hz - 220V/60Hz electrical supply

(1) With installed plug (if the plug is not necessary, remove it in accordance with gas train instruction manual indication)

(2) FS20D ≤ 180 kW with natural gas

The valve seal control device is compulsory (conforming to EN 676) on gas trains to burners with a maximum output over 1200 kW.

To select the gas train please refer to the technical data leaflet and/or instruction manual.

RIELLO 40 FSD SERIES

Burner accessories

Extended head kit

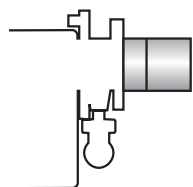

Burners "standard head" can be transformed into "extended head" versions by using the special kit. Here the KITS available for the various burners are listed, showing the original and the extended lengths.

BURNER	STANDARD HEAD LENGTH (mm)	EXTENDED HEAD LENGTH (mm)	KIT CODE
▶ FS5D	100	125	3000820
▶ FS20D	120	280	3000873

End cone with turbulator disk

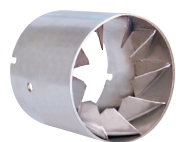

The end cone turbulator disk reduces the flame length. It is suitable for oven application (CO emissions) and short boiler chamber.

BURNER	PROJECTION (mm)	KIT CODE
▶ FS5D	+15	3000916
▶ FS20D	+23	3000919

LPG kit

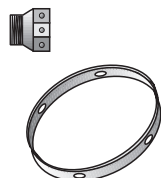

For burning LPG gas, a special kit is available to be fitted to the combustion head on the burner as shown in the following table.

BURNER	KIT CODE FOR STANDARD HEAD	KIT CODE FOR EXTENDED HEAD
▶ FS5D	3000882	3000882
▶ FS20D	3000886	3000886

Town gas kit

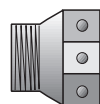

BURNER	KIT CODE
▶ FS5D	3000889
▶ FS20D	3000894

7-pin plug kit

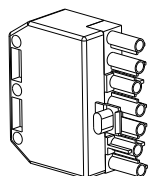

If necessary a 7-pin plug kit is available (in packaging of n. 5 pieces).

BURNER	KIT CODE
▶ FS5D - FS20D	3000945

Gas Oven Burners

RIELLO 40 FSD SERIES

Burner accessories

Continuous ventilation kit for RMG control box

If the burner requires continuous ventilation in the stages without flame, a special kit is available as given in the following table.

BURNER	KIT CODE
► FS20D	3010094

Remote reset control kit for MG 557 control box

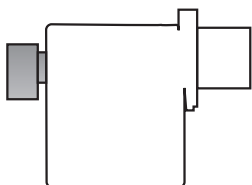

The MG 557 control box can be remotely released using an electric command kit. This kit must be installed in conformity with the local authority.

BURNER	KIT CODE
► FS5D	3002750

PC interface kit



To connect the control box to a personal computer for the transmission of operation, fault signals and detailed service information, an interface adapter with PC software are available.

BURNER	KIT CODE
► FS20D	3002719

Gas train accessories

Seal control kit



To test the valve seals on the gas train a special "seal control kit" is available.

GAS TRAIN	KIT CODE for 50 Hz operation	KIT CODE for 60 Hz operation
► MB/1 type	3010123	20168805

GULLIVER RSF SERIES

The Riello Gulliver RS5F, is a new model of the series of one stage gas burners, developed to respond to any request for light industrial processes like bakery ovens, spray painting ovens, small steam or thermal boilers and all applications which require a reliable, user-friendly industrial product with enhanced performance and specific functions.

The Gulliver RS5F series has an output ranging from 160 to 330 kW, uses the same components designed by Riello for the Gulliver series and have the same ventilation system and overall dimensions as the previous one stage gas model.

The burners are fitted with a microprocessor-based burner safety control box which supplies indication of operation and diagnosis of fault cause.

This new burner can operate on 50 or 60 Hz and a Voltage 220 - 230 Volt (dual frequency) and it is conform to the EN 676 Standard (Forced draught gas burners) and to European Directives for EMC, Low Voltage and Machinery. For depressurised working field see EN 746-2 Standard.

All the Gulliver RS5F burners are fired before leaving the factory.

Guidelines for installation of burners in conformity to EU Regulation:

A RIELLO burner (Heat Generator), where it is matched with a water-based boiler (Heater Housing) with a nominal output ≤ 400 kW, providing heat for heating purposes and heat to deliver sanitary hot water, can be installed:

- With boilers (heater housings) already in service in the field, for replacement of identical products, in conformity to Article 1, paragraph 2, point (G) of the EU Regulation No. 813/2013;
- With boilers (heater housings) on a new installation.

FIRING RATES

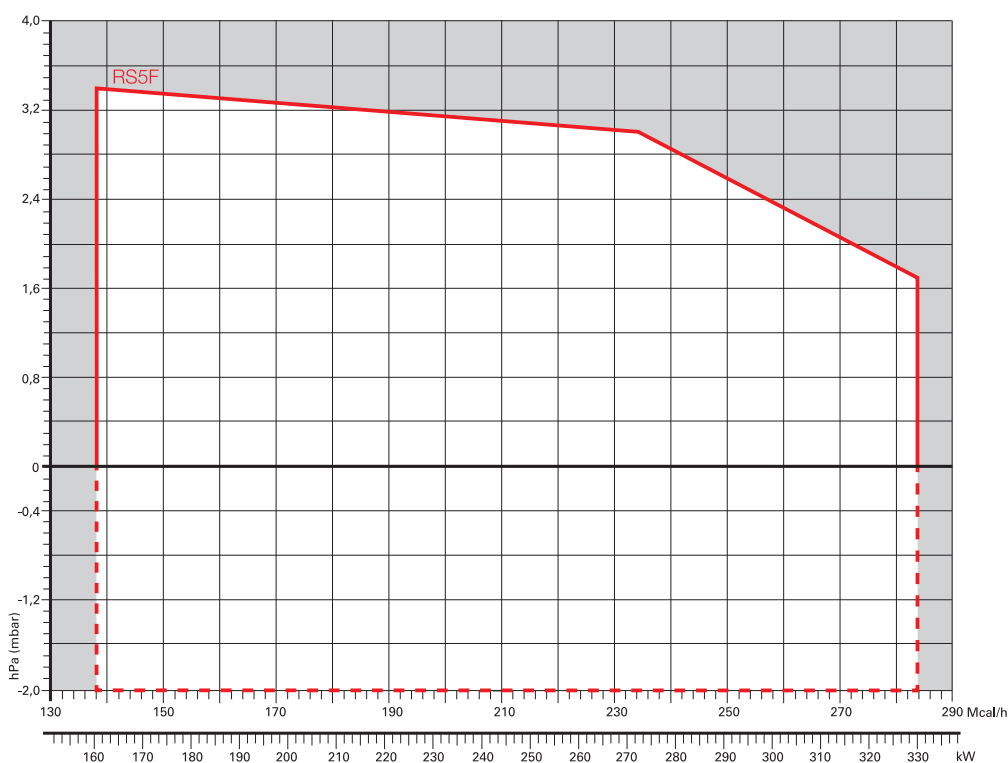

Useful working field for choosing the burner

Test conditions conforming to EN676
 Temperature: 20°C
 Pressure: 1013,5 mbar
 Altitude: 0 m a.s.l.

IMPORTANT:
 For the part of the working field that is depressurised, refer to EN 746-2 Standard.

RS5F

160 ÷ 330 kW

Gas Oven Burners

GULLIVER RSF SERIES

Overall dimensions (mm)

BURNER

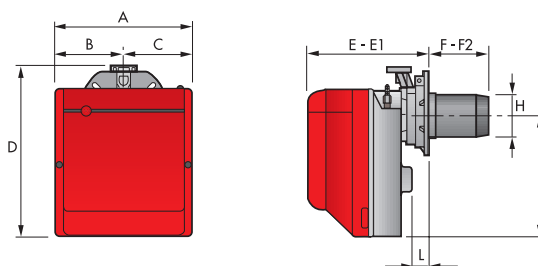

MODEL	A	B	C	D	E	E1	F	F2	H	I	L
► RS5F	300	150	150	392	278	300	225	203	137	286	45

BURNER - BOILER MOUNTING FLANGE

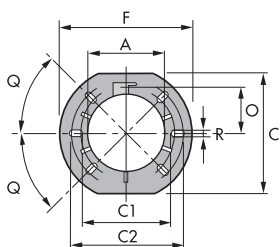

MODEL	A	C	C1	C2	F	O	Q	R
► RS5F	137	203	170	200	218	80,5	45°	11

PACKAGING

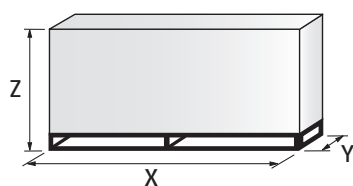

MODEL	X	Y	Z	kg
► RS5F	600	345	430	18

Specification

DESIGNATION OF SERIES

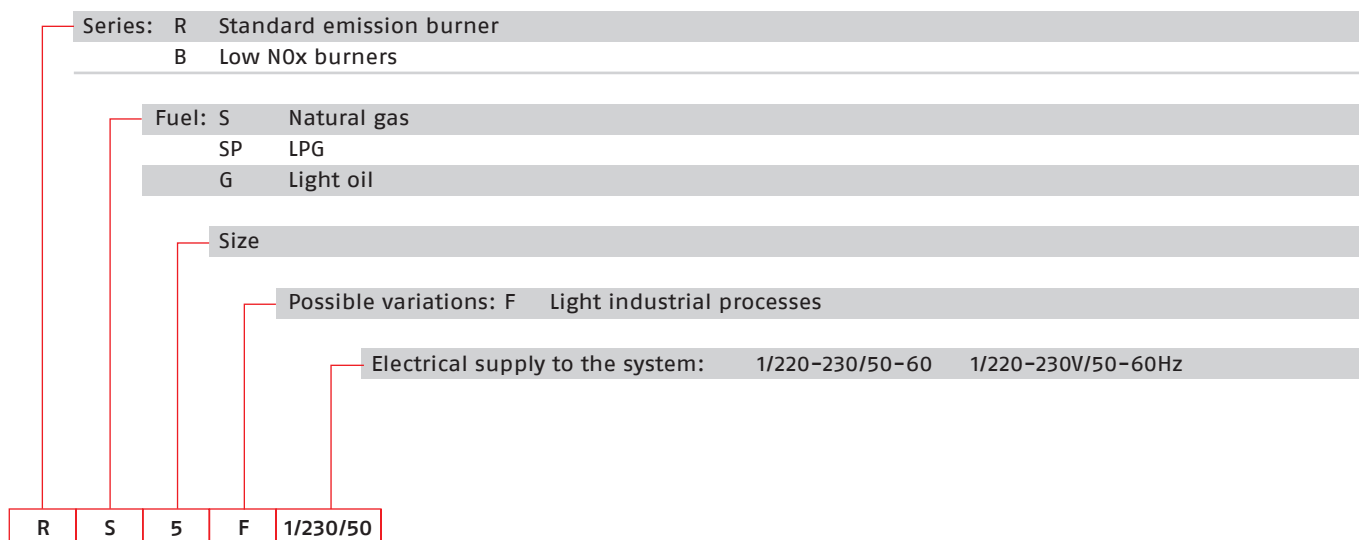

STATE OF SUPPLY

Monobloc, gas burner, completely automatic, one stage operation, made up of:

- Fan with forward curve blades
- Cover lined with sound-proofing material
- Air damper, always open in stand by, with external adjustment, with no need to remove the cover
- Single phase electric motor 220-230 V, 50-60 Hz
- Combustion head fitted with:
 - stainless steel head cone, resistant to high temperatures
 - ignition electrodes
 - ionisation probe
 - gas distributor
 - flame stability disk
- Flame inspection window
- Adjustable air pressure switch, with graduated selector, to guarantee burner lock out in the case of insufficient combustible air
- Microprocessor-based burner safety control box, with diagnostic and remote reset functions
- Protection filter against radio interference (included into burner safety control box)
- IP X0D (IP 40) electric protection level.

Standard equipment:

- Flange with insulating gasket
- Screw and nut for flange
- Screws and nuts for flange to be fixed to the heat generator
- 7-pin plug
- Remote control release kit
- Instruction handbook for installation, use and maintenance
- Spare parts catalogue.

Gas Oven Burners

GULLIVER RSF SERIES

Available models

Burners

CODE	MODEL	HEAT OUTPUT		TOTAL ELECTRICAL POWER (kW)	CERTIFICATION	NOTE
		(kW)	NATURAL GAS (Nm ³ /h)			
3761971	RS5F 1/220-230/50-60	160 - 330	16,0 - 33,0	0,430 (at 50 Hz) - 0,600 (at 60 Hz)	CE - 0085 BM0114	(1)

Net calorific value G20: 10 kWh/Nm³ - Density: 0,71 kg/Nm³.
The burners of RSF series are in according to EN 676.
(1) With plug and socket.

Gas Trains

GAS TRAIN CODE *	GAS TRAIN MODEL	NATURAL GAS		LPG		NOTE
		BURNER (type)	ADAPTER (code)	BURNER (type)	ADAPTER (code)	
3970549	MB 410/1 - F3SD 20	RS5F		RS5F		(1) (2)
3970550	MB 412/1 - F3SD 20	RS5F		RS5F		(1) (3)
3970558	MB 415/1 - F3SD 30	RS5F		RS5F		(1)

Please see Designation of Gas Train Series in the page before the Catalogue index.

* Gas trains are 230V/50Hz - 220V/60Hz electrical supply.

(1) With installed plug.

(2) RS5F ≤ 200 kW with natural gas.

(3) RS5F ≤ 300 kW with natural gas.

The valve seal control device is compulsory (conforming to EN 676) on gas trains to burners with a maximum output over 1200 kW.
To select the gas train please refer to the technical data leaflet and/or instruction manual.

Burner accessories

Extended head kit

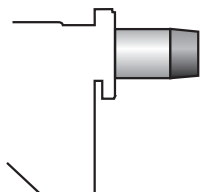

Burners standard head can be transformed into "extended head" versions by using the special kit.

BURNER	STANDARD HEAD LENGTH (mm)	EXTENDED HEAD LENGTH (mm)	KIT CODE
▶ RS5F	203 ÷ 225	302 ÷ 317	3001016

LPG kit



For burning LPG gas, a special kit is available to be fitted to the combustion head on the burner, as shown in the following table.

BURNER	KIT CODE FOR STANDARD HEAD	KIT CODE FOR EXTENDED HEAD
▶ RS5F	3001011	3001011

Burner accessories

Ground fault interrupter kit



A "Ground fault interrupter kit" is available as a safety device in case of electrical system fault. It is supplied with burners with pin plug.

BURNER	KIT CODE
▶ RS5F	3001180

Multibloc rotation kit

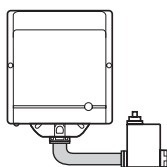

There is a special kit available that can be used to install the burner turned 180°. This kit is designed to ensure the gas train valve properly.

BURNER	KIT CODE
▶ RS5F	3001178

7-pin plug kit

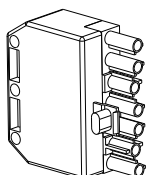

If necessary a 7-pin plug kit is available (in packaging of n. 5 pieces).

BURNER	KIT CODE
▶ RS5F	3000945

Gas train accessories

Seal control kit



To test the valve seals on the gas train a special "seal control kit" is available.

GAS TRAIN	KIT CODE	KIT CODE
	for 50 Hz operation	for 60 Hz operation
▶ MB/1 type	3010123	20168805

GULLIVER RS5DF SERIES

The Riello Gulliver RS5DF is a new model of the series of two stage gas burners, characterized for its small dimensions in spite of its high combustion performance. It has been developed to respond to any request for light industrial processes like bakery ovens, spray painting ovens, small steam or thermal boilers and all applications which require a reliable, user-friendly industrial product with enhanced performance and specific functions.

This model uses the same components designed by Riello for the Gulliver series. The high quality level guarantees safe working.

The burners are fitted with a microprocessor-based burner safety control box which supplies indication of operation and diagnosis of fault cause.

This new burner can operate on 50 or 60 Hz and a Voltage 220 - 230 Volt (dual frequency) and it is conform to the EN 676 Standard (Forced draught gas burners) and to European Directives for EMC, Low Voltage and Machinery. For depressurised working field see EN 746-2 Standard.

The Gulliver RS5DF burner is tested before leaving the factory.

Guidelines for installation of burners in conformity to EU Regulation:

A RIELLO burner (Heat Generator), where it is matched with a water-based boiler (Heater Housing) with a nominal output ≤ 400 kW, providing heat for heating purposes and heat to deliver sanitary hot water, can be installed:

- With boilers (heater housings) already in service in the field, for replacement of identical products, in conformity to Article 1, paragraph 2, point (G) of the EU Regulation No. 813/2013;
- With boilers (heater housings) on a new installation.



RS5DF 160/208 ÷ 345 kW

PROCESS
BURNERS

FIRING RATES

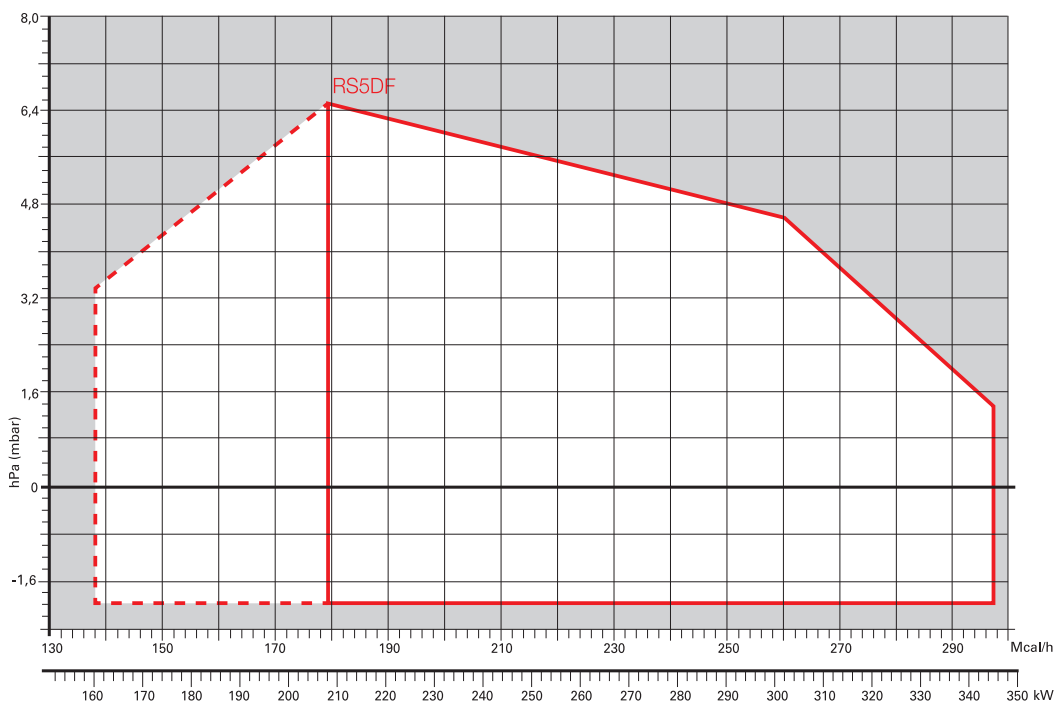

- Useful working field for choosing the burner
 - 1st stage operation range
- Test conditions conforming to EN676
 Temperature: 20°C
 Pressure: 1013,5 mbar
 Altitude: 0 m a.s.l.

Gas Oven Burners

GULLIVER RSDF SERIES

Overall dimensions (mm)

BURNER

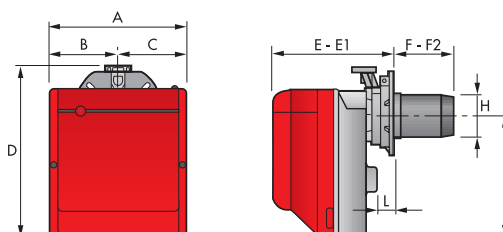

MODEL	A	B	C	D	E	E1	F	F2	H	I	L
► RS5DF	300	150	150	392	278	300	203	225	137	286	45

BURNER - BOILER MOUNTING FLANGE

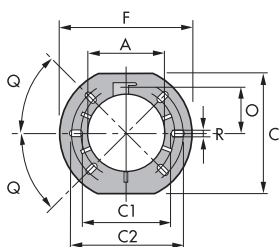

MODEL	A	C	C1	C2	F	O	Q	R
► RS5DF	137	203	170	200	218	80,5	45°	11

PACKAGING

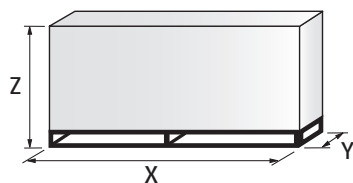

MODEL	X	Y	Z	kg
► RS5DF	600	345	430	18

GULLIVER RSDF SERIES

Specification

DESIGNATION OF SERIES

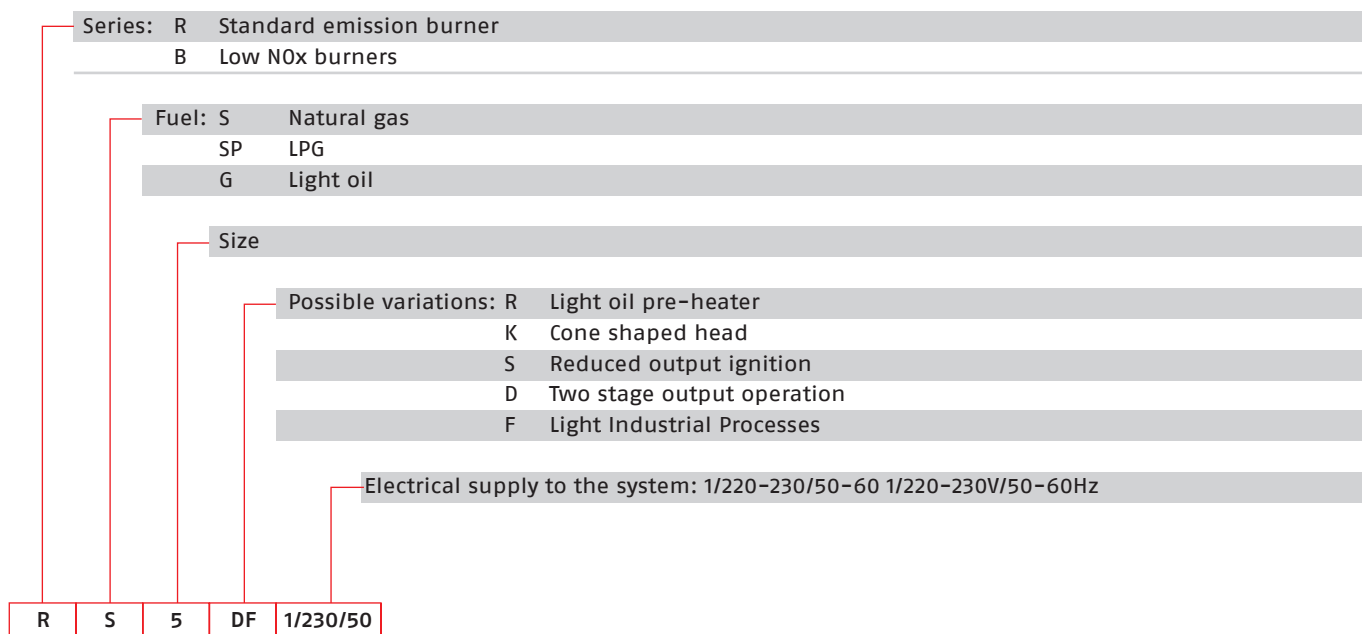

STATE OF SUPPLY

Monoblock, gas burner, completely automatic, with two stage settings fitted with:

- Fan with forward curve blades
- Cover lined with sound - proofing material
- Air damper, with 1st and 2nd stage adjustment, driven by an electric servomotor
- Single phase electric motor 220-230 V / 50-60 Hz
- Combustion head fitted with:
 - stainless steel head cone, resistant to high temperatures
 - ignition electrodes
 - ionisation probe
 - gas distributor
 - flame stability disk
- Flame inspection window
- Adjustable air pressure switch, with graduated selector, to guarantee burner lock out in the case of insufficient combustible air
- Microprocessor-based burner safety control box, with diagnostic and remote reset functions
- Protection filter against radio interference (included into burner safety control box)
- IP X0D (IP 40) electric protection level.

Standard equipment:

- Sliding flange
- Flange insulation screen
- Screws and nuts for fixing the flange to the boiler
- 7-pin plug
- 4-pin plug
- Remote control release kit
- Instruction handbook for installation, use and maintenance
- Spare parts catalogue.

Gas Oven Burners

GULLIVER RSDF SERIES

Available models

Burners

CODE	MODEL	HEAT OUTPUT		TOTAL ELECTRICAL POWER (kW)	CERTIFICATION	NOTE
		(kW)	NATURAL GAS (Nm ³ /h)			
3761991	RS5DF 1/220-230/50-60	160/208 - 345	16/20,8 - 34,5	0,450 (at 50 Hz) - 0,60 (at 60 Hz)	-	(1)

Net calorific value G20: 10 kWh/Nm³ - Density: 0,71 kg/Nm³.
The burners of RSD series are in according to EN 676.
(1) With plug and socket.

Gas Trains

GAS TRAIN CODE *	GAS TRAIN MODEL	NATURAL GAS		LPG		NOTE
		BURNER (type)	ADAPTER (code)	BURNER (type)	ADAPTER (code)	
3970542	MB 410/2 - F3SD 20	RS5DF		RS5DF		(1) (2)
3970543	MB 412/2 - F3SD 20	RS5DF		RS5DF		(1) (3)
3970582	MB 415/2 - F3SD 20	RS5DF		RS5DF		(1)

Please see Designation of Gas Train Series in the page before the Catalogue index.

* Gas trains are 230V/50Hz - 220V/60Hz electrical supply.

(1) With installed plug.

(2) RS5D ≤ 200 kW with natural gas.

(3) RS5D ≤ 300 kW with natural gas.

The valve seal control device is compulsory (conforming to EN 676) on gas trains to burners with a maximum output over 1200 kW.
To select the gas train please refer to the technical data leaflet and/or instruction manual.

Burner accessories

Extended head kit

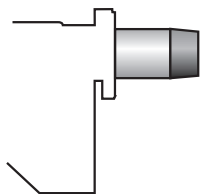

Burners standard head can be transformed into "extended head" versions by using the special kit.

BURNER	STANDARD HEAD LENGTH (mm)	EXTENDED HEAD LENGTH (mm)	KIT CODE
▶ RS5DF	203 ÷ 225	357 ÷ 372	3001016

LPG kit



For burning LPG gas, a special kit is available to be fitted to the combustion head on the burner, as shown in the following table.

BURNER	KIT CODE FOR STANDARD HEAD	KIT CODE FOR EXTENDED HEAD
▶ RS5DF	3001011	3001011

Burner accessories

Ground fault interrupter kit



A "Ground fault interrupter kit" is available as a safety device in case of electrical system fault. It is supplied with burners with pin plug.

BURNER	KIT CODE
▶ RS5DF	3001180

Multibloc rotation kit

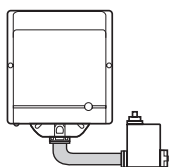

There is a special kit available that can be used to install the burner turned 180°. This kit is designed to ensure the gas train valve properly.

BURNER	KIT CODE
▶ RS5DF	3001178

7-pin plug kit

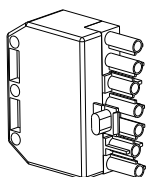

If necessary a 7-pin plug kit is available (in packaging of n. 5 pieces).

BURNER	KIT CODE
▶ RS5DF	3000945

Gas train accessories

Seal control kit



To test the valve seals on the gas train a special "seal control kit" is available.

GAS TRAIN	KIT CODE for 50 Hz operation	KIT CODE for 60 Hz operation
▶ MB/1 type	3010123	20168805

RX S/PV F SERIES

The RX S/PV F gas burner series with linear flame for light process applications has been designed and developed by Riello, based on the premix combustion technology. The adopted technical solutions represent the best answer to obtain low pollutant emissions, high performance and wide modulating turn down ratio. The in-depth study of fluid dynamics and the use of innovative porous materials has allowed a flame to be distributed throughout the length of the combustion zone and stability even in environments characterized by turbulence and internal recirculations. The sealed fans equipped with brushless motors allow speed variations. Moreover, the use of proportional valves guarantees a perfect control of the power output and reduced electrical consumption. The complete autonomy of each burner allows the optimization of the temperature distribution inside the oven and simplifies the realization of the plant. The use of certified components and the easy maintenance makes RX gas burner a highly reliable product. The microprocessor control box, integrated with the valve, has been developed exclusively for RIELLO. RX S/PV F series is strongly oriented to customer needs: burners are tailor made developed and provided for each specific application. The premix models are therefore not orderable as standard products but only in the versions assuring a matching to target applications. A wide range of configuration is available to comply with every customer ovens specification. RX S/PV F products permit the complete autonomy of each burner allows the optimization of the temperature distribution inside the oven and simplifies the realization of the plant.



PROCESS
BURNERS

APPLICATIONS

Use of the RX S/PV F range is addressed to convection ovens, of the type rotary or with fixed pans, in plates, conductive and irradiation, as well as industrial ovens of continuous type, tunnel and tube type of steam. Also possibility of replacement on electric ovens is available.

FIRING RATES

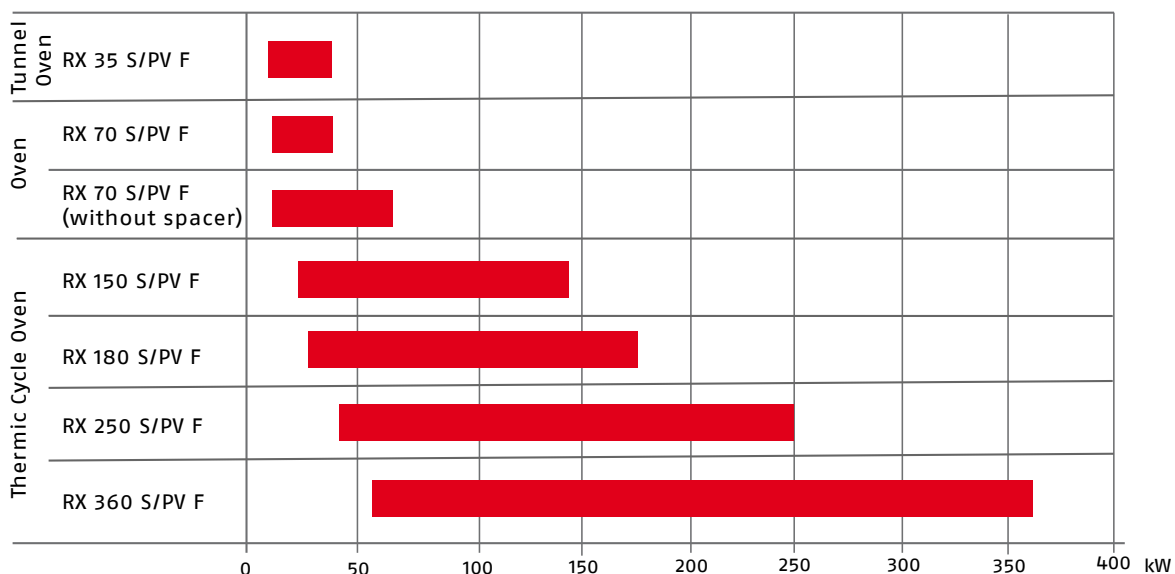

Gas Oven Burners

RX S/PV F SERIES

Overall dimensions (mm)

BURNER

RX 35 S/PV F

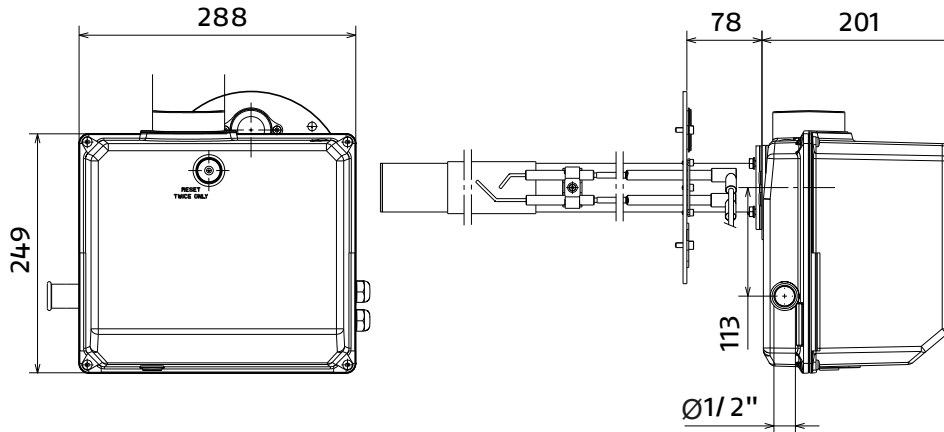

COMBUSTION HEAD

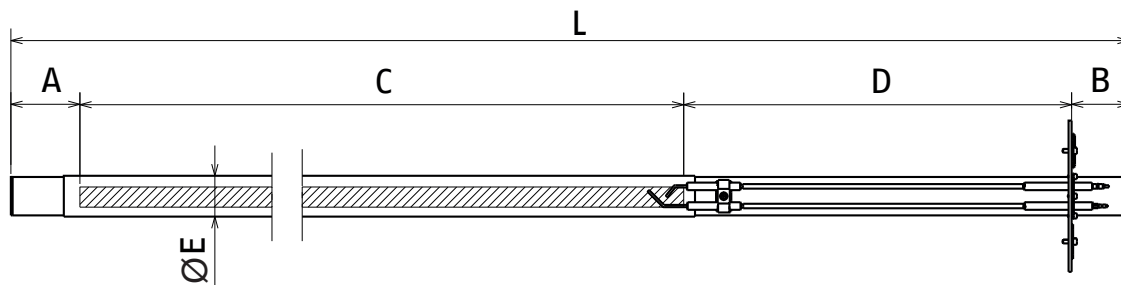

CODE	A	B	C	D	E	L	NOTE
▶ 20110452	106	85	1000	518	50	1709	
▶ 20110544	106	85	1000	518	60	1709	(1)
▶ 20095286	106	85	1206	518	50	1915	
▶ 20095407	106	85	1206	518	60	1915	(1)
▶ 20045263	106	85	1400	518	50	2110	
▶ 20134436	106	85	1400	518	60	2110	(1)
▶ 20131416	106	85	1506	518	50	2215	
▶ 20131419	106	85	1506	518	60	2215	(1)

C: combustion zone length; it should coincide with the tape's width of the tunnel oven.

(1) The three-flame version can be used when it is necessary to adapt the temperature inside the oven. The combustion head assembly is characterized by three zones (1) (2) (3) that can deliver a different power output. The adjustment of these zones is carried out in easy way using a screws on the modulator.

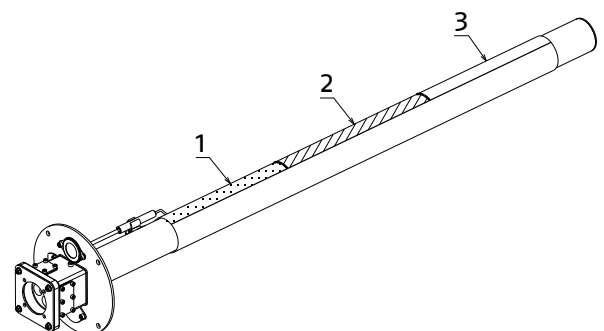

Overall dimensions (mm)

BURNER (HEAD INCLUDED)

RX 70 S/PV F
 RX 70 S/PV F (WITHOUT SPACER)

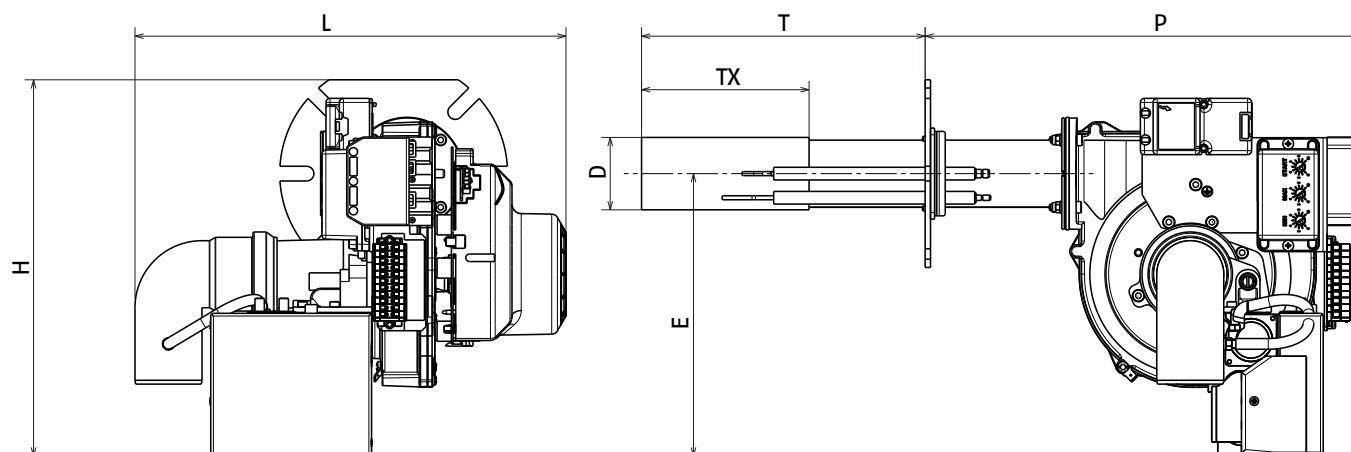

mm	H	L	P	T	TX	D	E
▶ RX 70 S/PV F	280	320	325	212	125	54	210
▶ RX 70 S/PV F (without spacer)	280	313	225	296	185	67	210

TX: combustion zone length.

PACKAGING

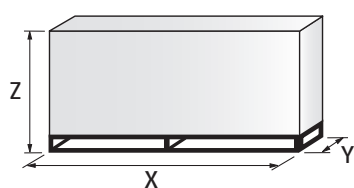

mm	X	Y	Z
▶ RX 70 S/PV F	590	395	305
▶ RX 70 S/PV F (without spacer)	590	395	305

Gas Oven Burners

RX S/PV F SERIES

Overall dimensions (mm)

BURNER

RX 150 S/PV F

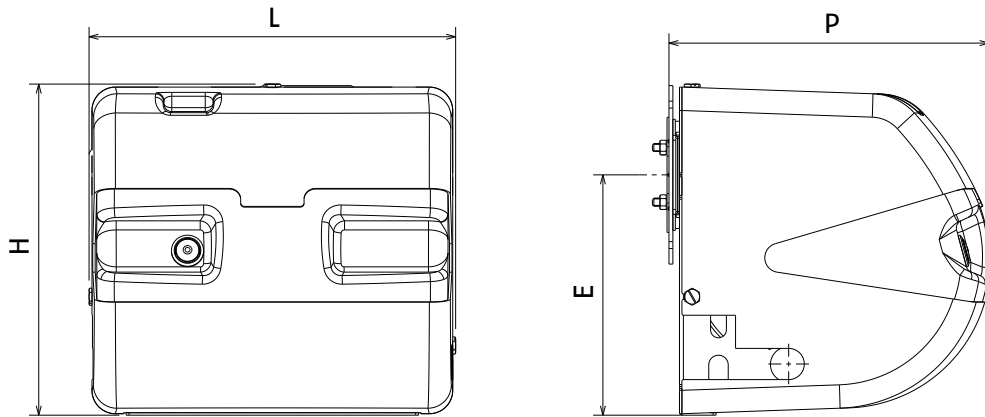

mm	H	L	P	E
▶ RX 150 S/PV F TC	340	380	330	247
▶ RX 150 S/PV F TL	340	380	330	247

COMBUSTION HEAD

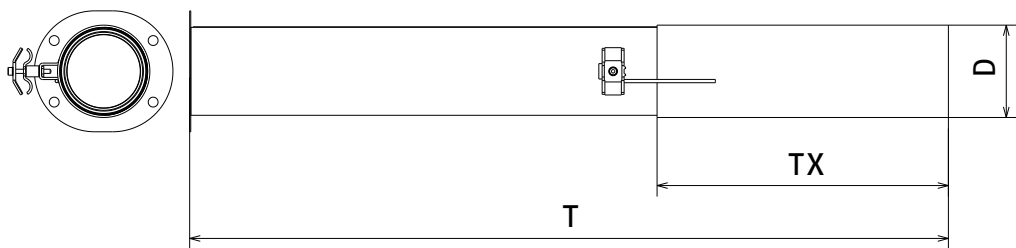

BURNER	COMBUSTION HEAD ASSEMBLY	T	TX	D
▶ RX 150 S/PV F TC	SUPPLIED HEAD	392	265	84
▶ RX 150 S/PV F TL	20048844	690	265	84

TX: combustion zone length.

PACKAGING

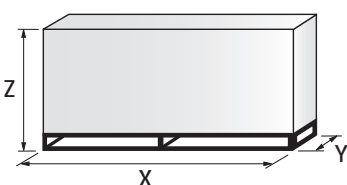

mm	X	Y	Z
▶ RX 150 S/PV F TC	778	398	476
▶ RX 150 S/PV F TL	778	398	476

Overall dimensions (mm)

BURNER

RX 180 S/PV F TC
 RX 250 S/PV F TC

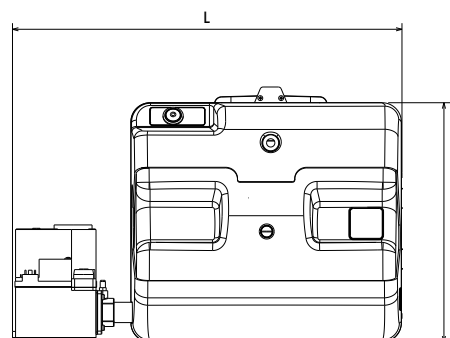
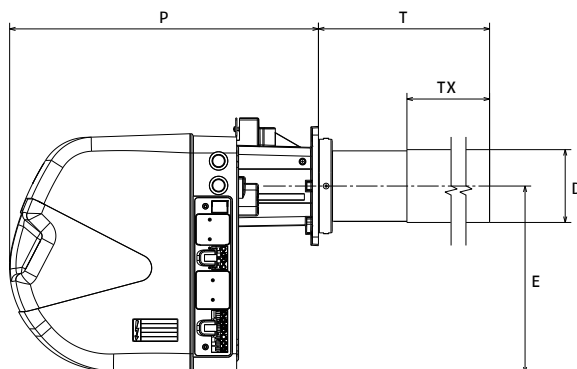

RX 180 S/PV F TL
 RX 250 S/PV F TL

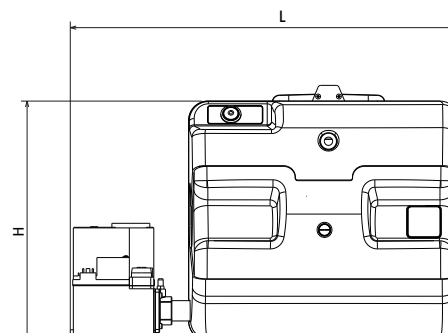
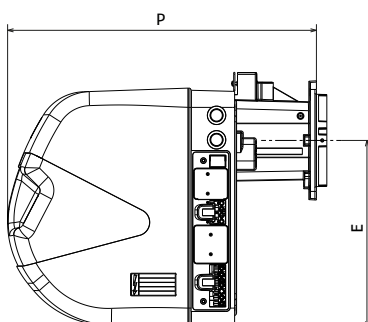

mm	H	L	P	E	T	TX	D
▶ RX 180 S/PV F TC	390	640	503	306	465	320	119
▶ RX 250 S/PV F TC	390	640	503	306	465	320	119
▶ RX 180 S/PV F TL	390	640	503	306	-	-	-
▶ RX 250 S/PV F TL	390	640	503	306	-	-	-

COMBUSTION HEAD

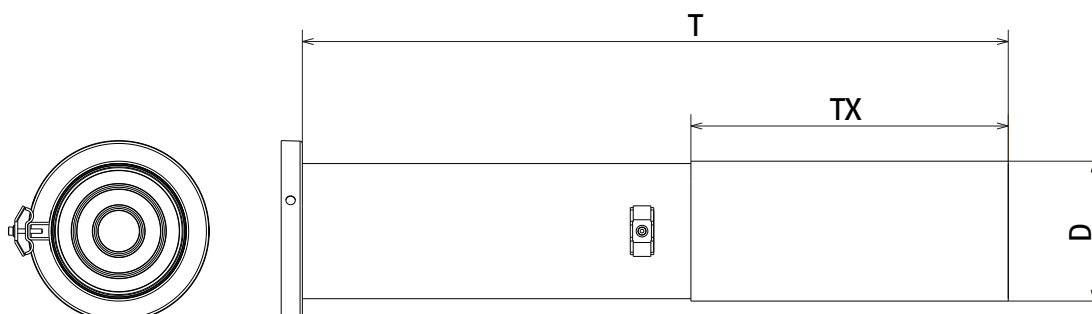

BURNER	COMBUSTION HEAD ASSEMBLY	T	TX	D
▶ RX 180 S/PV F TC	SUPPLIED HEAD	160	460	119
▶ RX 250 S/PV F TC	SUPPLIED HEAD	160	460	119
▶ RX 180 S/PV F TL	20028729	600	250	119
	20054833	500	150	119
▶ RX 250 S/PV F TL	20058677	690	250	119

TX: combustion zone length.

Gas Oven Burners

RX S/PV F SERIES

Overall dimensions (mm)

BURNER

RX 180 S/PV F TL
RX 250 S/PV F TL

PACKAGING

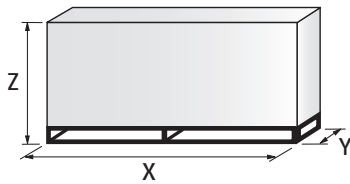

mm	X	Y	Z
▶ RX 180 S/PV F TC	730	550	530
▶ RX 250 S/PV F TC	730	550	530
▶ RX 180 S/PV F TL	730	550	530
▶ RX 250 S/PV F TL	730	550	530

BURNER

RX 360 S/PV F

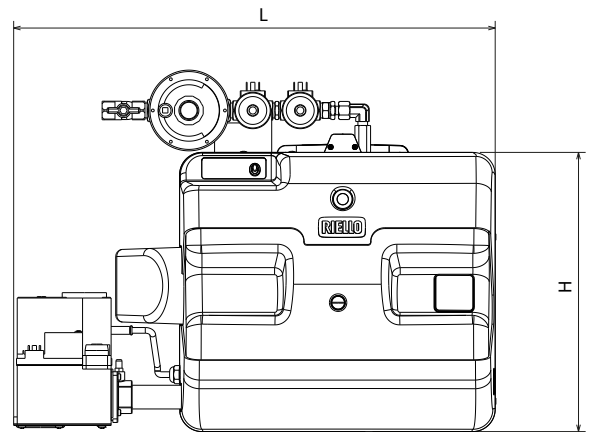
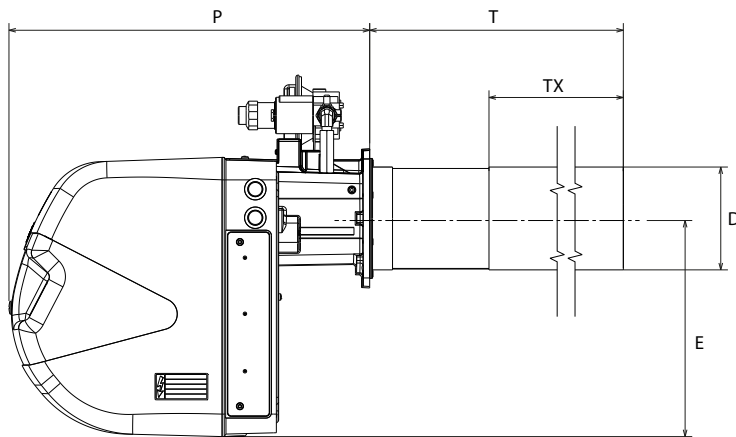

mm	H	L	P	T	TX	D	E
▶ RX 360 S/PV F	390	675	502	635	410	144	306

TX: combustion zone length.

PACKAGING

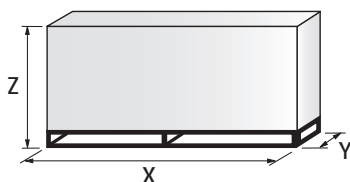

mm	X	Y	Z
▶ RX 360 S/PV F	1218	564	485

Specification

DESIGNATION OF SERIES

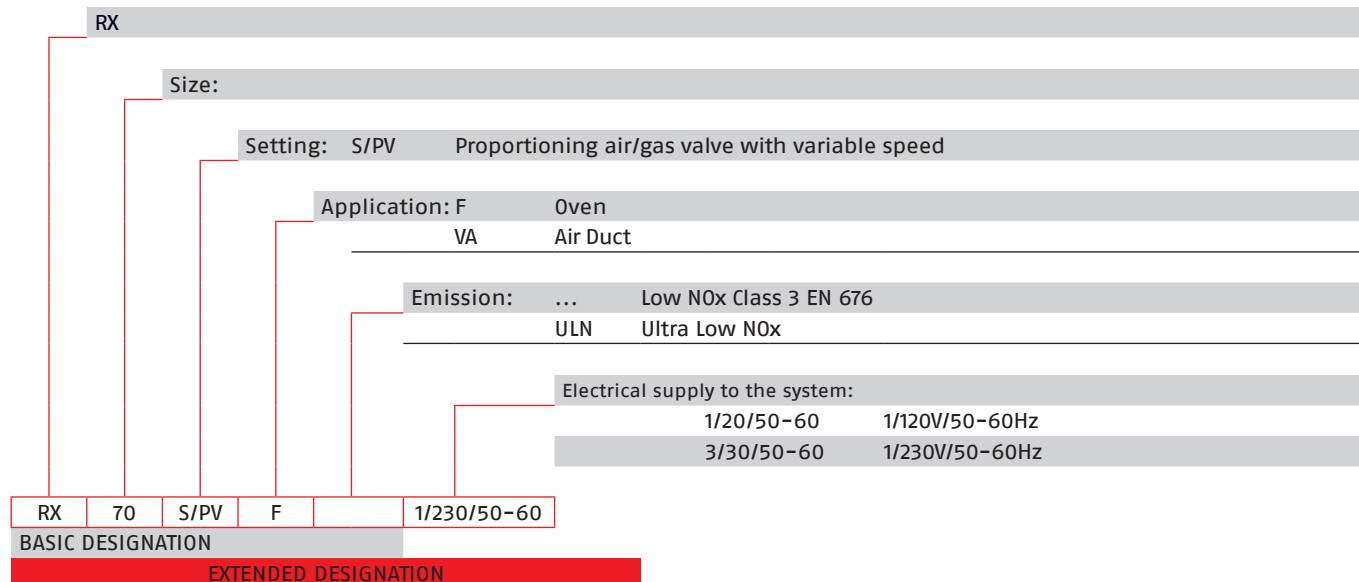

AVAILABLE SPECIFICATIONS

RX S/PV F series are strongly oriented to customer needs: burners are tailor made developed and provided for each specific application.

The premix models are therefore not orderable as standard products but only in the versions assuring a matching to target applications.

A wide range of configuration is available to comply with every customer ovens specification.

RX S/PV F products permit the complete autonomy of each burner allows the optimization of the temperature distribution inside the oven and simplifies the realization of the plant.

- **Available power output:**
 - From 5 to 60 kW
- **Available electrical supply:**
 - 1/230/50-60
 - 1/120/50-60
- **Fuel:**
 - Natural Gas
 - LPG
- **Operating mode:**
 - One stage
 - Two Stage Progressive
 - Modulating
- **Modulation signal input:**
 - 0-10 V
 - 4-20 A
 - 3-point modulation or Up/Down
- **Aesthetic**
 - With cover
 - Without cover
- **Combustion head**
 - Cylindrical or frontal shaped head
 - One or three different combustion zones
 - Customizable length and cross section
- **Other:**
 - Variable speed brushless motor
 - Compact proportional valve
 - Diagnostic via PC
 - Possibility of canalize the air circuit
 - Possibility of discharge in the environment
 - Programmable pre-purging, post-purging, safety time
 - BUS management
 - Wide modulating turn down ratio up to 1:8 with shutdowns/starts-up
 - On field or EN 676 certification

Gas Oven Burners

RX S/PV F SERIES

Available models

Burners

CODE	MODEL	FUEL	MAIN APPLICATION	HEAT OUTPUT (kW)	HEAD ASSEMBLY	EXTERNAL MODULATION	NOTE
20042815	RX 35 S/PV F 1/230/50-60	Natural Gas/ LPG	Tunnel Oven	6-40	Not Included	0-10 V	(1)
20140590	RX 70 S/PV F 1/230/50	Natural Gas/ LPG	Oven	10-40	Included	0-10 V	(1)
20144823	RX 70 S/PV F 1/230/50	Natural Gas/ LPG	Oven	10-40	Included	3 Points	(1)
20026963	RX 70 S/PV F 1/230/50-60	Natural Gas/ LPG	Oven	14-70	Included	3 Points	(1)(3)
20138689	RX 150 S/PV F TC 1/230/50-60	Natural Gas/ LPG	Thermal Cycle Oven	25-145	Included	3 Points	(1)
20139759	RX 150 S/PV F TL 1/230/50-60	Natural Gas/ LPG	Thermal Cycle Oven	25-145	Not Included	0-10 V	(1)
20135846	RX 180 S/PV F TC 1/230/50-60	Natural Gas/ LPG	Thermal Cycle Oven	30-180	Included	3 Points	(1)
20137565	RX 180 S/PV F TL 1/230/50-60	Natural Gas/ LPG	Thermal Cycle Oven	30-180	Not Included	0-10 V	(1)
20134866	RX 250 S/PV F TC 1/230/50-60	Natural Gas/ LPG	Thermal Cycle Oven	42-250	Included	3 Points	(1)
20137510	RX 250 S/PV F TL 1/230/50-60	Natural Gas/ LPG	Thermal Cycle Oven	42-250	Not Included	0-10 V	(1)
20148871	RX 360 S/PV F 1/230/50	Natural Gas/ LPG	Thermal Cycle Oven	65-360	Included	3 Points	(2)

(1): External modulation signal as per factory setting. Refer to the installation manual for compatibility with other signals

(2): with pilot ignition

(3): without spacer

Burner accessories

BUS control

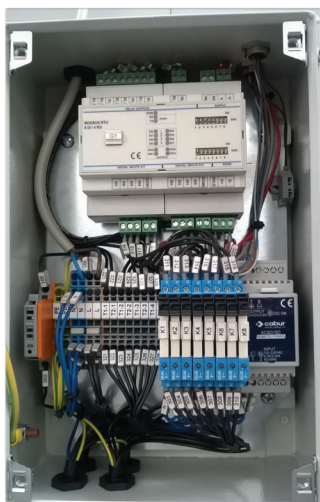

It is used to simplify the wiring harness in the plants with a large number of installed burners.

This accessory consists of an I/O module contained in an IP65 metal box (called sub-panel). The sub-panel can manage from 1 to 4 burners and can be connected in "sequence" using the bus connection cable for a maximum of 31 sub-panels (124 burners in all).

By means of the BUS system, for each connected burner, it is possible to manage : burner ON/OFF, signaling of burner operation or lock-out. Thanks to the configuration parameters adjustable via dip-switches, the system is easy to set up both in case of new installation and replacement.

In order to guarantee the plant safety, the device is equipped with a Watch-Dog timer system; If the module does not receive commands for a longer time than the set time, the WatchDog Alarm will be triggered and the burners will be switched off (thermostat opening) to avoid system damages.

- Modbus Slave module on RS-485 net
- MODBUS RTU/ MODBUS ASCII
- 8-digital input channels
- 4-digital output channels with relay (2 SPDT format + 2 SPST format)
- Communication parameters set via dip-switch
- Watch-Dog alarm
- Remote configuration
- Remote configuration
- LED signaling on the front side for power supply and communication
- LED signaling on the front side for digital inputs and outputs
- Connection to extractable terminals

BURNER

CODE

► RX 35 S/PV F

(A)

(A) Please contact Riello Burners Commercial and Technical Department, our Application Engineers will be pleased to help you.

Burner accessories

Accessories for modulating operation

POWER CONTROLLER



To obtain modulating operation, the RX S/PV F series of burners requires a regulator with three point outlet controls. The following table lists the accessories for modulating operation with their application range.

BURNER	REGULATOR TYPE	REGULATOR CODE
▶ RX 180 S/PV F	RWF 50.2 – Basic version with 3 position output	20094733
▶ RX 250 S/PV F		
▶ RX 360 S/PV F	RWF 50.2 – Basic version with 3 position output	20086840

PROBE



The relative temperature or pressure probes fitted to the regulator, must be chosen on the basis of the application.

BURNER	PROBE TYPE	RANGE (°C) (bar)	PROBE CODE
▶ All models	Temperature PT 100	-100 ÷ 500°C	3010110
	Pressure 4 ÷ 20 mA	0 ÷ 2,5 bar	3010213
	Pressure 4 ÷ 20 mA	0 ÷ 16 bar	3010214
	Pressure 4 ÷ 20 mA	0 ÷ 25 bar	3090873

PC interface kit

A special kit is available for the connection with a PC and the indication of hours of operation, number and types of blocks, number of engine revolutions and parameters safety.

BURNER	KIT CODE
▶ RX 70 S/PV F	On Demand
▶ RX 150 S/PV F	
▶ RX 180 S/PV F	
▶ RX 250 S/PV F	
▶ RX 360 S/PV F	

Display and Operating Unit

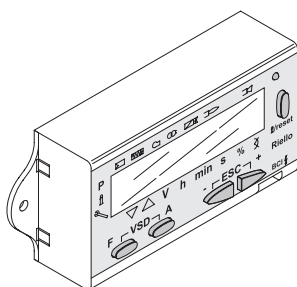

The AZL 21 LCD display Kit is suitable to be connected to the LME 71 control box in order to get indication of the operating status, to activate the diagnostic functions and to change the password-protected parameters (carried out only by qualified personnel)

BURNER	KIT CODE
▶ RX 150 S/PV F	20109292
▶ RX 180 S/PV F	
▶ RX 250 S/PV F	
▶ RX 360 S/PV F	

RS VA SERIES

Riello series RS 5-28-38-50-70 VA and RS 28-38-50-70/M VA of monoblock air duct burner is designed for the installation in low-medium temperature direct air heating system, such as painting booths ones.

These burners are strongly performing when used in applications with:

- High recirculation ratio: the embedded air fan ensure the right oxidizer air flow rate
- High variability of the air flow to be treated: combustion head is crossed by homogeneous oxidizing air flow ensuring the right air/fuel ratio in every point of the combustion head
- Presence of impurities in the air to be treated: the protection of the combustion head from the primary air flow avoid depositing of impurities on the combustion module, preserving efficiency and durability over the time



FIRING RATES

Burners fire rate depends on the size of fitted head and on the pressure in the duct section.

Air duct pressure = 0-3 mbar

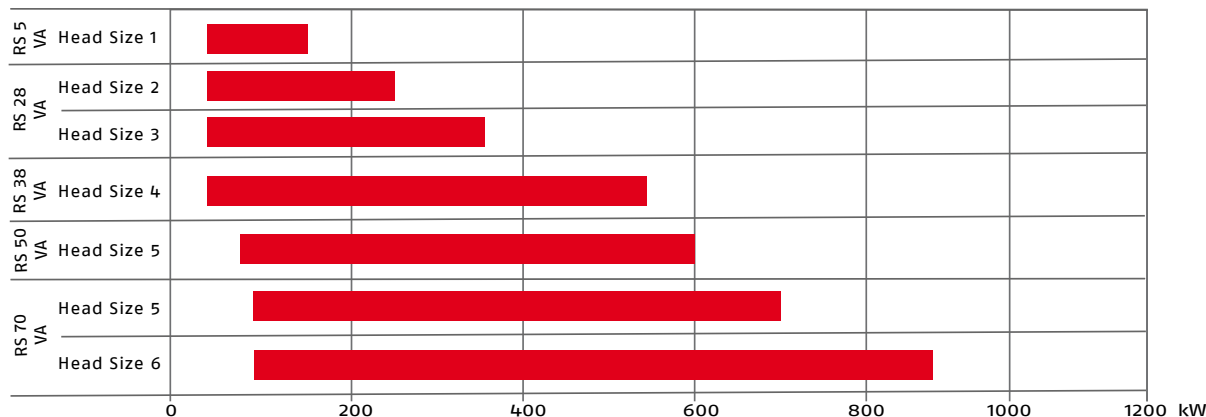

Air duct pressure > 3 mbar

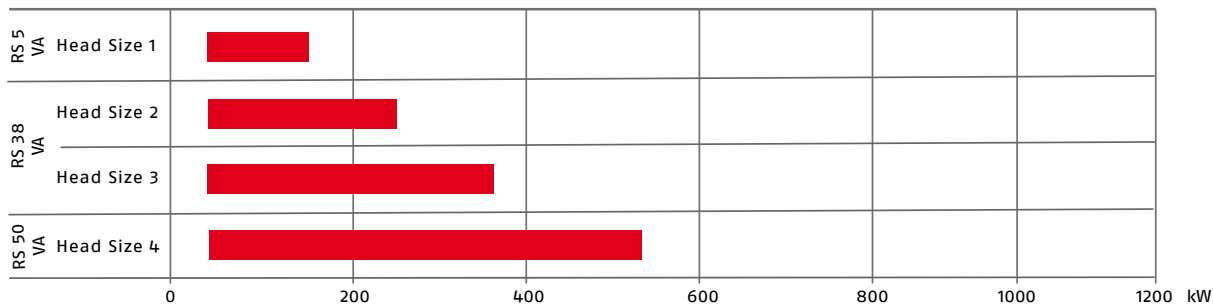

Air Duct Burners

RS VA SERIES

Overall dimensions (mm)

VENTILATING STRUCTURE

RS 5 VA

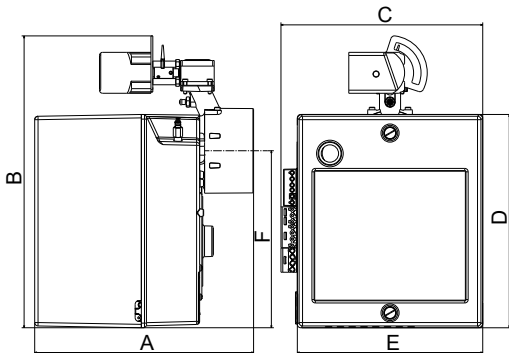

RS 28-38-50 VA

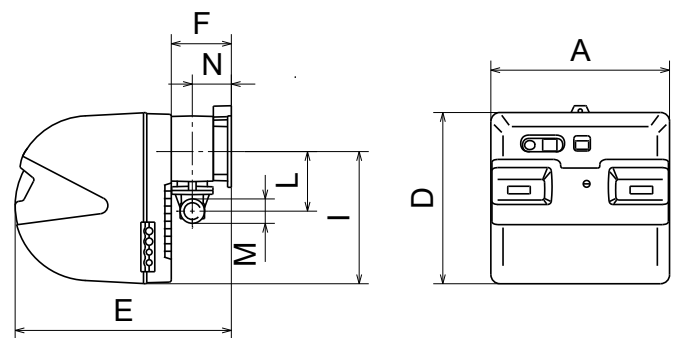

RS 70 VA

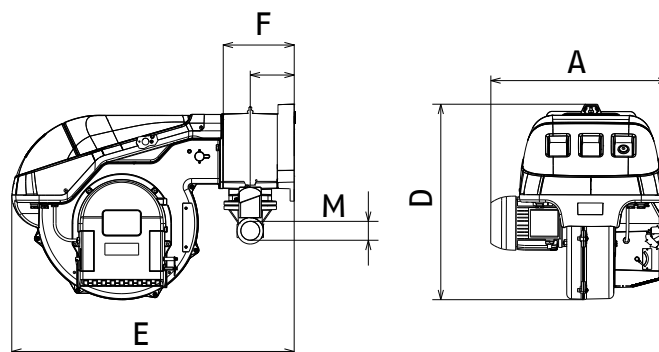

MODEL	A	B	C	D	E	F	I	L	M	N
▶ RS 5 VA	353	471	325	344	302	286	-	-	-	-
▶ RS 28 VA	476	-	-	474	580	164	352	168	1" 1/2	108
▶ RS 38 VA	476	-	-	474	580	164	352	168	1" 1/2	108
▶ RS 50 VA	476	-	-	474	580	164	352	168	1" 1/2	108
▶ RS 70 VA	523.5	-	-	577	836	210	-	-	2"	130

RS VA SERIES

Overall dimensions (mm)

HEAD ASSEMBLY

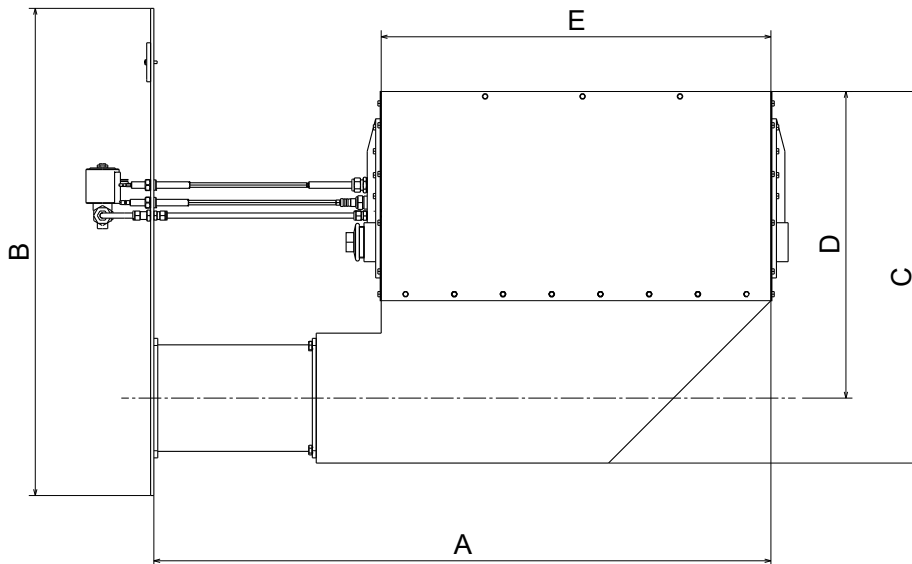

MODEL	HEAD SIZE	A	B	C	D	E
RS 5 VA	1/250	661	750	574	453	307
	1/750	1161				
RS 28-38-50 VA	2/110	656	750	574	451	450
	2/250	796				
	2/350	896				
	2/500	1046				
	2/750	1296				
	2/1000	1546				
	3/250	946	750	574	451	600
	3/350	1046				
	3/500	1196				
	3/750	1446				
	3/1000	1696				
	4/110	1106				
	4/250	1246	750	574	451	900
	4/250	1246				
	4/500	1496				
	4/750	1746				
	4/1000	1996				
	4/1500	2496				
5/250	1546	750	574	451	1200	
5/500	1796					
5/750	2046					
5/1000	2296					
5/1500	2796					

MODEL	HEAD SIZE	A	B	C	D	E
RS 70 VA	5/250	1746	800	574	451	1200
	5/500	1996				
	5/750	2246				
	5/1000	2496				
	6/250	2046				1500
	6/500	2296				
	6/750	2546				
	6/1000	2796				

Air Duct Burners

RS VA SERIES

Overall dimensions (mm)

FIXING PLATE

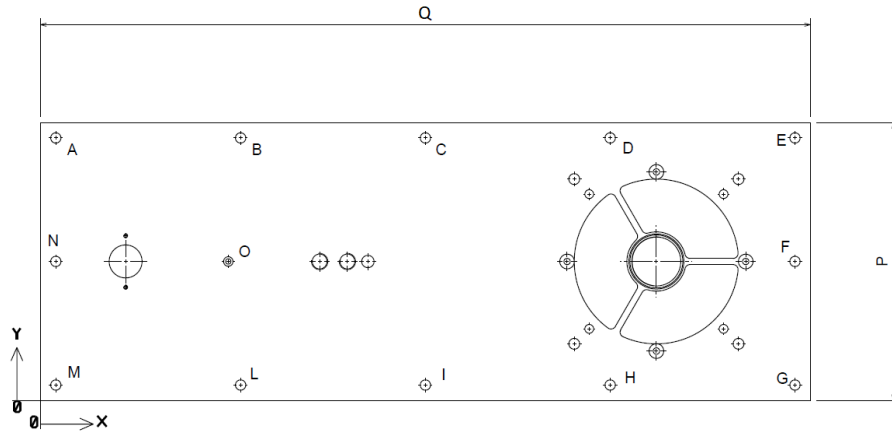

MODEL	HOLES	X	Y	Ø	L	P
RS 5-28-38-50 VA	A	15	255	10	750	270
	B	195	255	10		
	C	375	255	10		
	D	555	255	10		
	E	735	255	10		
	F	735	135	10		
	G	735	15	10		
	H	555	15	10		
	I	375	15	10		
	L	195	15	10		
	M	15	15	10		
	N	15	135	10		
	"O (RS 5 VA only)"	183	135	5,2		
RS 70 VA	A	20	330	10	800	350
	B	210	330	10		
	C	400	330	10		
	D	590	330	10		
	E	780	330	10		
	F	780	175	10		
	G	780	20	10		
	H	570	20	10		
	I	400	20	10		
	L	210	20	10		
	M	20	20	10		
	N	20	175	10		
	O	-	-	-		

RS VA SERIES

Overall dimensions (mm)

PACKAGING

The ventilation structures are shipped in cardboard boxes with the overall dimensions shown in the table. The weight of the ventilation structure, complete with packaging, is indicated in the table.

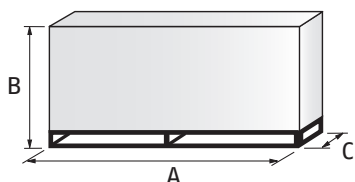

MODEL	A	B	C	kg
▶ RS 5 VA	460	505	340	17
▶ RS 28 VA	872-1007	550	540	38
▶ RS 38 VA	872-1007	550	540	40
▶ RS 50 VA	872-1007	550	540	41
▶ RS 70 VA	1405	740	692	70

The head assemblies are shipped on pallets with the dimensions shown in the table.

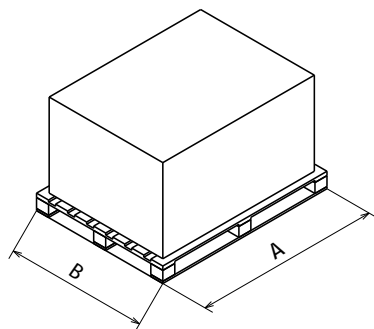

HEAD SIZE	A	B
1/250	1200	800
2/250	1000	800
2/500	1200	800
2/750	1800	800
2/1000	1800	800
3/250	1200	800
3/500	1400	1000
3/750	1800	800
3/1000	2200	800
4/250	1400	1000
4/500	1800	800
4/750	2200	800
4/1000	2200	800
5/250	1800	800
5/500	2200	800
5/750	2200	800
5/1000	2600	800
5/250	2200	850
5/500	2200	850
5/750	2700	850
5/1000	2700	850
5/1500	3400	940
6/250	2200	850
6/500	2700	850
6/750	2700	850
6/1000	3400	940

Air Duct Burners

RS VA SERIES

Configurations

STANDARD CONFIGURATION

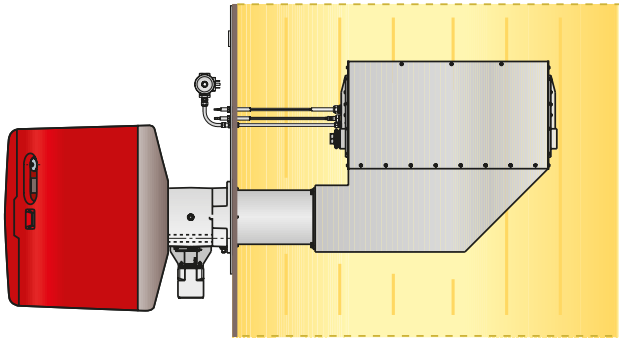

L1 - Angle configuration with combustion head developed in horizontal in primary air duct

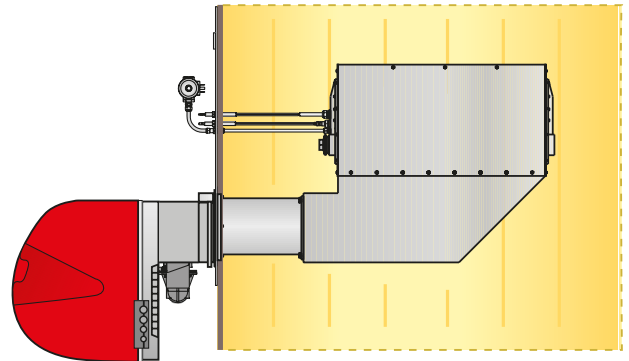

L2 - Angle configuration with combustion head developed in vertical in primary air duct

Available models

AVAILABLE BURNERS STRUCTURE

BURNER MODEL		RS 5 VA	RS 28 VA	RS 38 VA	RS 50 VA	RS 70 VA
			RS 28/M VA	RS 38/M VA	RS 50/M VA	RS 70/M VA
FUEL	Natural Gas	•	•	•	•	•
	LPG	•	•	•	•	•
ELECTRICAL SUPPLY	1/230/50 Hz	•	•	•		
	1/220-230/60Hz	◆	•	•		
	3/230-400/50Hz		◆	•	•	•
AUXILIARY	3/208-230/380-460/60 Hz		◆	◆	◆	◆
	230/50-60 Hz	•	•	•	•	•
	110/50-60 Hz	◆	◆	◆	◆	◆
CONFIGURATION	L1 - Angle configuration with combustion head developed in horizontal in primary air duct	•	•	•	•	•
	L2 - Angle configuration with combustion head developed in vertical in primary air duct	◆	◆	◆	◆	◆
OPERATION	Two stage/Fixed Air	•	•	•	•	•
	Modulating/ Air adjustment with mechanical cam		•	•	•	•

- Standard
- ◆ On Demand

For more informations about product codes, please contact Riello Commercial and Technical departments, our Application Engineers will be pleased to help you.

RS VA SERIES

AVAILABLE HEAD ASSEMBLY

The table shows the possible combinations between the structures and the combustion heads available. Power values are to be considered with ignition pilot off and with the following reference conditions: ambient temperature 20 ° C, gas temperature 15 ° C, pressure barometric 1013 mbar, altitude 0 m s.l.m

SIZE	LENGHT [mm]	p<3 mbar *	p>3 mbar *	Pmin [kW]	Pmax [kW]
1	250	RS 5 VA	RS 5 VA	20	180
	750				
2	110	RS 28 VA	RS 38 VA	30	270
	250				
	350				
	500				
	750				
3	1000	RS 28 VA	RS 38 VA	30	360
	250				
	350				
	500				
	750				
4	1000	RS 38 VA	RS 50 VA	30	530
	1500				
	110				
	250				
	500				
5	750	RS 50 VA	-	110	600
	1000				
	250				
	500				
5	750	RS 70 VA	-	150	720
	1000				
	1500				
	250				
6	500	RS 70 VA	-	150	900
	750				
	1000				

* Please refers to the pressure in the air duct section.

For the application of the depressurized combustion head or for more informations about product codes, please contact Riello Commercial and Technical departments, our Application Engineers will be pleased to help you."

STATE OF SUPPLY

- Screws to fix the flange
- Thermal screen
- Plugs for 4 - 5 - 6 - 7 poles electrical connections
- Flexible piping for ignition pilot
- Pilot train assembly
- Pilot train fixing fittings with main gas train
- Instruction handbook for installation, use and maintenance
- Spare parts catalogue.

Burner accessories

Accessories for modulating operation

POWER CONTROLLER



To obtain modulating operation, the burners requires a regulator with three point outlet controls. The following table lists the accessories for modulating operation with their application range.

BURNER	REGULATOR TYPE
▶ RS 28-38-50-70 VA	RWF 50
	RWF 55

POWER CONTROLLER



Modulating operation can also be obtained with an analog control signal converter and a feedback three-pole potentiometer. Alternatively, the potentiometer can be used to check the servomotor position.

BURNER	TYPE (INPUT SIGNAL)
▶ RS 28-38-50-70 VA	0/2 - 10 V (impedance 200 K Ω) 0/4 - 20 mA (impedance 250 Ω)

POTENTIOMETER

BURNER
▶ RS 28-38-50-70 VA

Continuous ventilation kit



If the burner requires continuous ventilation in the stages without flame, a special kit is available as given in the following table.

BURNER
▶ RS 28-38-50-70 VA

Ground fault interrupter kit



BURNER
▶ RS 28-38-50-70 VA

RS VA SERIES

Specification

DESIGNATION OF SERIES

A specific index guides your choice of burner from the various models available in the RS VA series. Below is a clear and detailed specification description of the product.

Series: R	
Fuel: S Natural Gas	
L Light oil	
LS Light oil/Natural Gas	
N Heavy oil	
Size:	
Setting: /1 Single stage	
Two stage	
/M Modulating-Mechanical cam	
Application: VA Air Duct	
Emission:	... or C01 Class 1 EN676
MZ	Class 2 EN676
BLU	Class 3 EN676
MX	Class 3 ENE676
Electrical supply to the system:	
1/230/50	1/230V/50Hz
3/230/50	3/230V/50Hz
3/400/50	3N/400V/50Hz
3/230-400/50	3/230V/50Hz - 3N/400V/50Hz
3/220/60	3/220V/60Hz
3/380/60	3N/380V/60Hz
3/220-380/60	3/220/60Hz - 3N/380V/60Hz
Auxiliary voltage: 230/50-60 230V/50-60H	
110/50-60 110V/50-60Hz	

R	S	70		VA		3/230-400/50	230/50-60
---	---	----	--	----	--	--------------	-----------

BASIC DESIGNATION

EXTENDED DESIGNATION

RX S/PV VA

The Riello RX S/PV VA series of modulating premix gas burner, is a range of product developed to respond to direct exchange application (e.g paint booth).

The RX S/PV series is available in five different models, with an output ranging for 22 to 400 kW.

The burners are fitted with a micro-processor based safety control which supplies indication of operation and diagnosis fault cases.

Burners can operate on 50 or 60 Hz (dual-frequency).

Also combustion head over a wide range of different lengths are available, meeting every application needs.

Burners can operate with LPG also by means of a simple regulation on the gas valve.

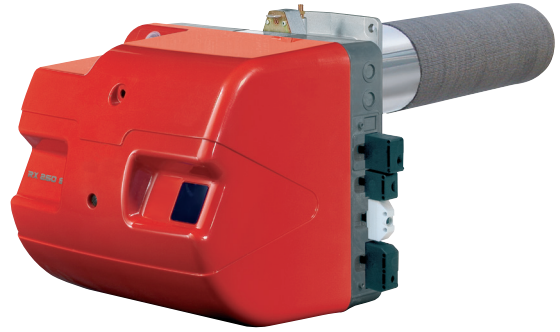

FIRING RATES

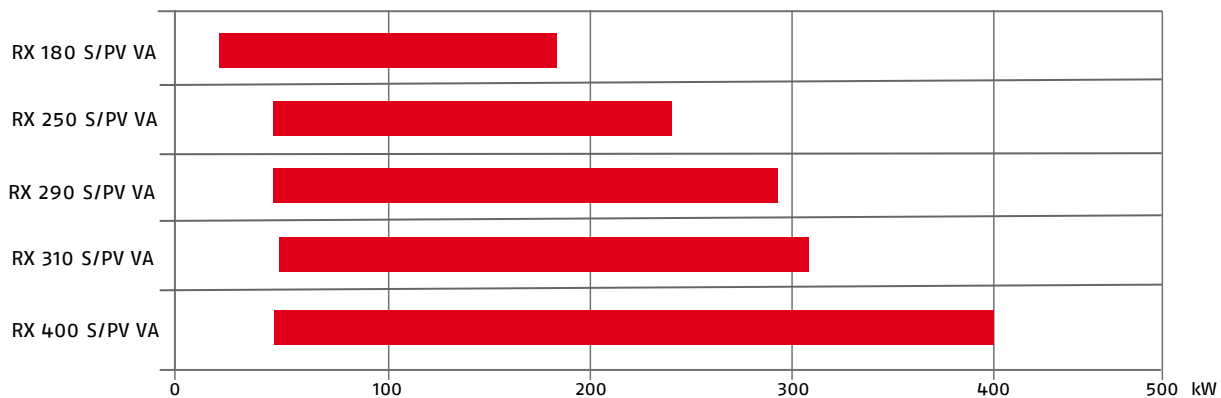

Air Duct Burners

RX S/PV VA SERIES

Overall dimensions (mm)

VENTILATING STRUCTURE

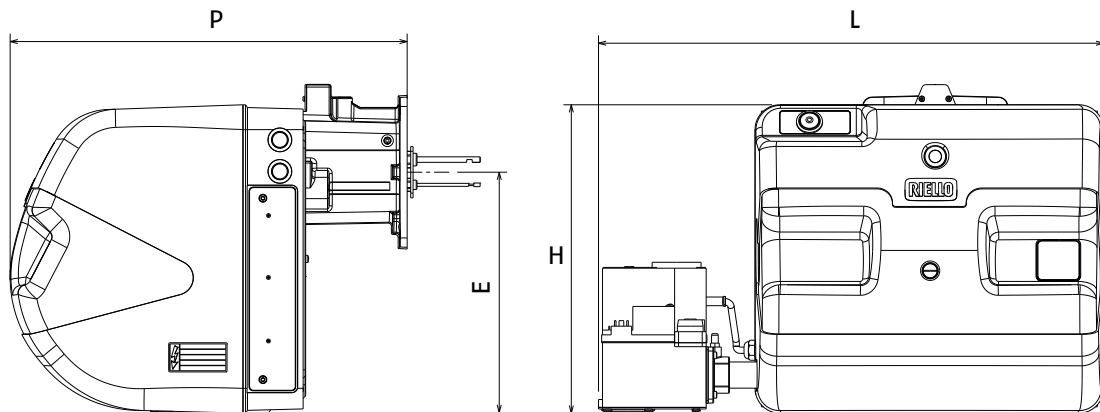

MODEL	H	L	P	E
▶ RS 180 S/PV VA	390	640	503	306
▶ RS 250 S/PV VA	390	640	503	306
▶ RS 290 S/PV VA	390	640	503	306
▶ RS 310 S/PV VA	390	640	503	306
▶ RS 400 S/PV VA	457	707	524	353

COMBUSTION HEADS

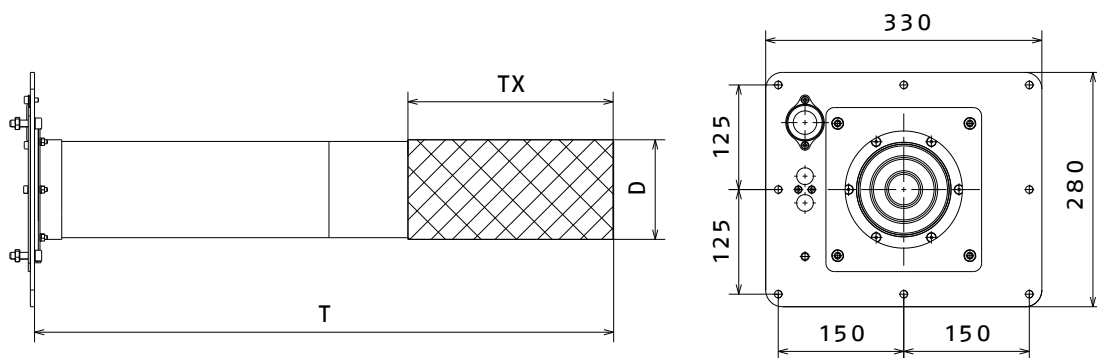

Several combustion head sizes are available

HEAD ASSEMBLY	T	TX	D
▶ 3151000-20085194	1000	350	119
▶ 3151002-20069560	1250	350	119
▶ 3151003-20085180	1470	350	119
▶ 20025306	1000	250	119
▶ 3151001	1250	450	119
▶ 3151004	1570	450	119

TX is the flame zone length

Overall dimensions (mm)

PACKAGING

The ventilating structures and the head assemblies are shipped in cardboard boxes with the overall dimensions shown in the table.

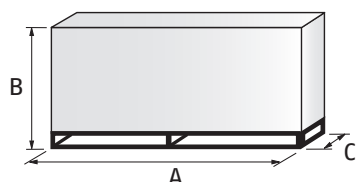

BURNER MODEL	A	B	C
▶ RX 180 S/PV VA	1000	500	485
▶ RX 250 S/PV VA	1000	500	485
▶ RX 290 S/PV VA	1000	500	485
▶ RX 310 S/PV VA	1000	500	485
▶ RX 400 S/PV VA	1000	500	485

HEAD LENGTH	A	B	C
▶ T = 1000	1065	283	345
▶ T = 250	1315	283	345
▶ T = 1470	1535	283	345
▶ T = 1570	1635	283	345

Available models

Burners

CODE	MODEL	HEAT OUTPUT (kW)	TOTAL ELECTRICAL POWER (kW)	NOTE
20141998	RX 180 S/PV VA 1/230/50-60	25-180	0,51	(1)
20141388	RX 250 S/PV VA 1/230/50-60	42-250	0,51	(1)
20141857	RX 290 S/PV VA 1/230/50-60	42-290	0,51	(1)(2)
20141861	RX 310 S/PV VA 1/230/50-60	50-310	0,51	(1)
20140981	RX 400 S/PV VA 1/230/50-60	45-400	1,0	(1)

(1) 0-10V external modulation

(2) This maximum power is obtained only with depression exchange channels.

Combustion Heads

BURNER	HEAD ASSEMBLY	LENGTH
RX 180 S/PV VA	20025306	T = 1000
	3151000	T = 1000
RX 250-290-310 S/PV VA	3151002	T = 1250
	3151003	T = 1470
	20085194	T = 1000 High temperature
	20069560	T = 1250 High temperature
	20085180	T = 1470 High temperature
	RX 400 S/PV VA	3151000
3151001		T = 1250
3151004		T = 1570

Air Duct Burners

RX S/PV VA SERIES

Specification

DESIGNATION OF SERIES

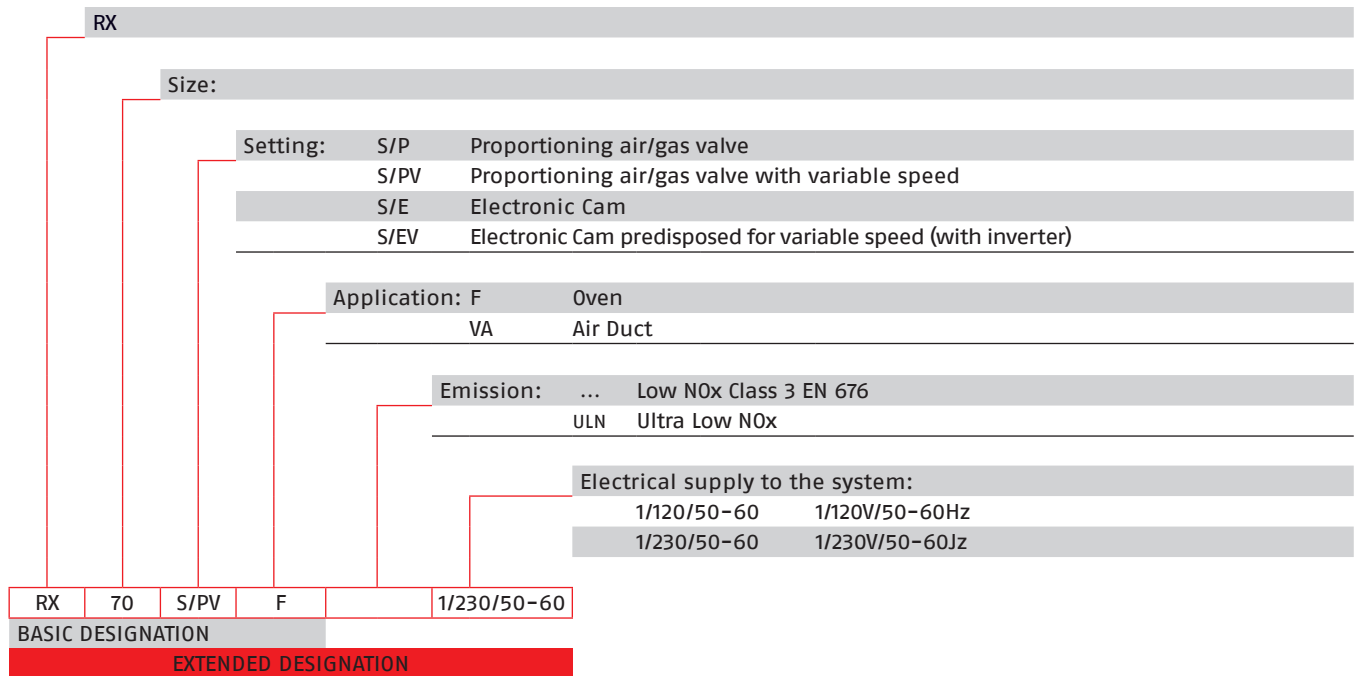

STATE OF SUPPLY

- Flange for gas valve
- Screws to fix the valve
- Gas valve
- 2, 4 and 7-pole plugs
- Gas pipe (only for RX 400 S/PV VA)
- Hood protection (only for RX 400 S/PV VA)
- Fixing screw
- Instruction handbook for installation, use and maintenance
- Spare parts catalogue.

Burner accessories

Accessories for modulating operation

POWER CONTROLLER



To obtain modulating operation, the RX S/E series of burners requires a regulator with three point outlet controls. The following table lists the accessories for modulating operation with their application range.

BURNER	REGULATOR TYPE	REGULATOR CODE
▶ RX 180-250-290-310-400 S/PV VA	RWF 50.2	20086840
▶ RX 400 S/PV VA	RWF 50.2	20095185

PROBE



The relative temperature or pressure probes fitted to the regulator, must be chosen on the basis of the application.

BURNER	PROBE TYPE	RANGE (°C) (bar)	PROBE CODE
▶ RX 180-250-290-310-400 S/PV VA	Temperature PT 100	-100 ÷ 500°C	3010110
	Pressure 4 ÷ 20 mA	0 ÷ 2,5 bar	3010213
	Pressure 4 ÷ 20 mA	0 ÷ 16 bar	3010214
	Pressure 4 ÷ 20 mA	0 ÷ 25 bar	3090873

Display and Operating Unit

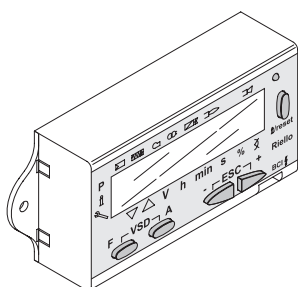

The AZL 21 LCD display Kit is available to be connected to the LME 71 control box in order to get indication of the operating status, to activate the diagnostic functions and to change the password-protected parameters (carried out only by qualified personnel)

BURNER	KIT CODE
▶ RX 180-250-290-310-400 S/PV VA	20109292

Gas Valve space saving kit

BURNER	KIT CODE
▶ RX 180-250-290-310-400 S/PV VA	20016843

Diagnostic software kit

A special kit is available that identifies the life of the burner by connecting to a PC indicating hours of operation, number and types of blocks, number of engine revolutions and parameters safety.

BURNER	KIT CODE
▶ RX 180-250-290-310-400 S/PV VA	On demand

BP R

The gas burners of the "BP R" series have a light and handy structure, reduced overall dimensions and this is why they are ideal for all the installations requiring a compact and silent combustion unit with high turndown ratio.

The burner structure is in painted carbon steel; parts in contact with the flame are in refractory steel and in Nickel Chrome alloys.

Externally to the burner, with a layout that depends on installation requirements, the following are located: the gas train, the combustion air fan and the flame control box. Maximum power is 1450 kW (while minimum power can be up to 5 kW).

The completely automatic operation allows for different controls such as on-off, high-low flame, modulating on gas or modulating on air ratio. These latter allow to obtain a turndown ratio of up to 50:1 with neutral combustion chamber.

The burner can be supplied in the following versions:

- Installed inside the duct (duct-type);
- Installed outside the duct;

According with customers needs, special executions, that can include complete equipment of combustion system, can be developed.

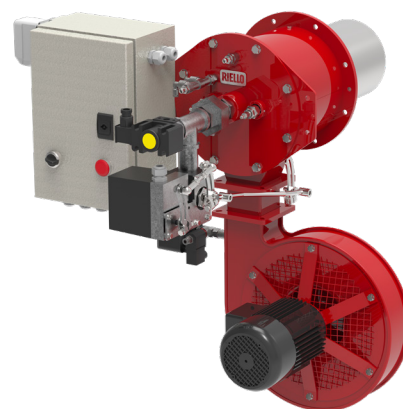
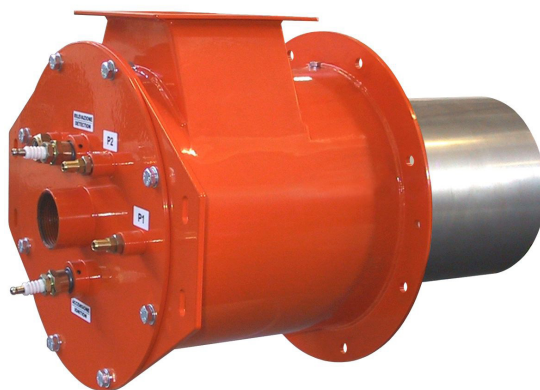

APPLICATIONS

- Ceramic, Tile, Refractory industries: Roller dryers, Tunnel dryers, Continuous and intermittent dryers
- Textile industry: Stenter, Dryers, Polymerising devices, Print dryers
- Surface treatment: Dryers/kilns and paint furnaces
- Paper industry: Air heaters for Drying hoods
- Converting industry: Air heaters for Rotogravure and Flexographic printing machinery, Adhesive coating machines
- Food industry: Cereal dryers, Roasting machines
- Tobacco drying

Firing Rates

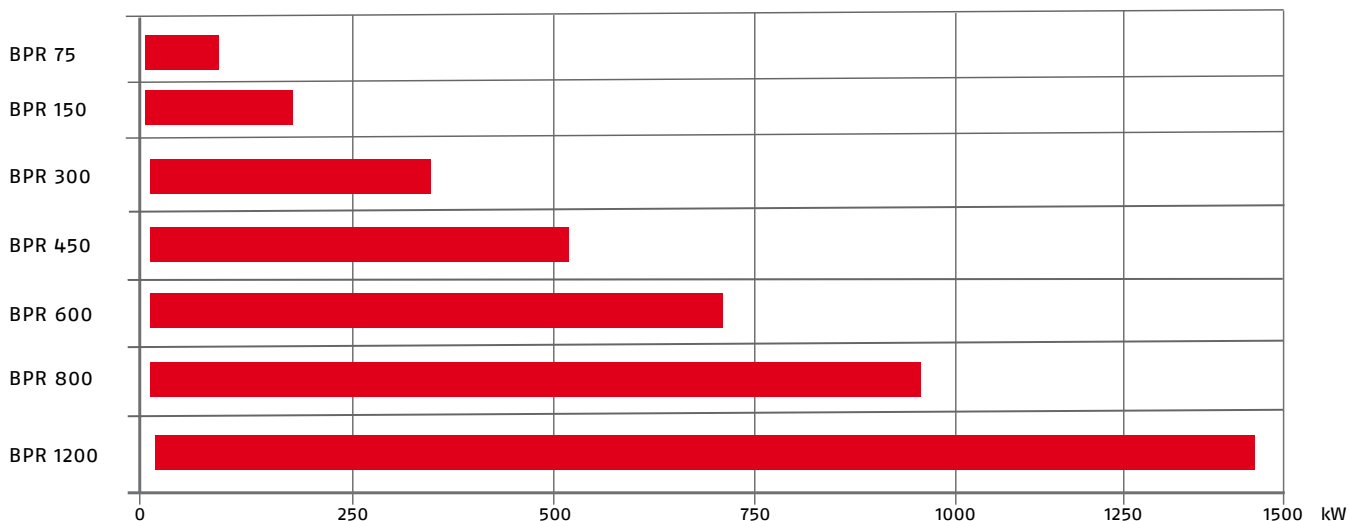

High Ratio Adjustment Burners

BP R

Overall dimensions (mm)

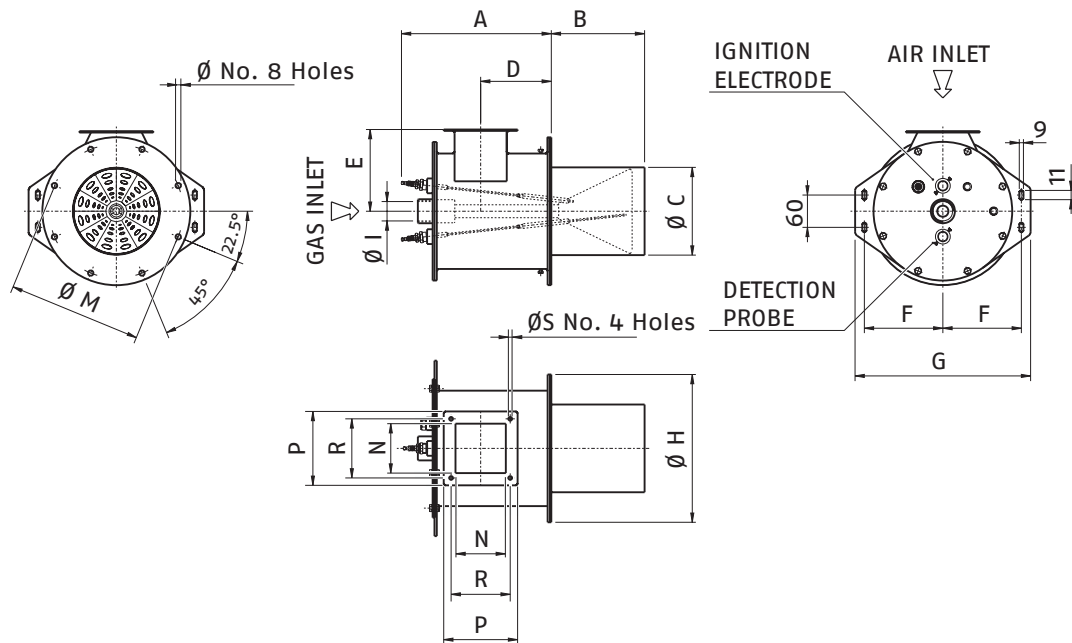

MODEL	A	B	$\varnothing C$	D	E	F	G	$\varnothing H$	$\varnothing I$	$\varnothing L$	$\varnothing M$	N	P	R	$\varnothing S$
▶ BP R 75	270	210	110	140	120	120	270	250	3/4"	9,5	225	66	105	85	7
▶ BP R 150	275	205	145	145	150	140	310	250	1"	9,5	225	66	105	85	7
▶ BP R 300	320	205	190	150	180	170	380	320	1 1/2"	11,5	290	114	160	128	9
▶ BP R 450	370	215	220	200	220	195	430	370	1 1/2"	11,5	340	140	190	165	10
▶ BP R 600	370	215	220	200	220	195	430	370	1 1/2"	11,5	340	140	190	165	10

Specification

FEATURES

- Turndown ratio up to 50:1
- Thermal steel flame tube
- Direct spark ignition, ionisation-type flame detection
- Standard versions are for natural gas and LPG. Versions for other gases available on request
- Available as complete unit, with gas train with right or left hand layout
- Single phase or 3 phase motor, 50/60 Hz.
- Easy to install, start, operate
- Instruction handbook for installation, use and maintenance
- Spare parts catalogue.

Available models

MODEL	POWER RANGE [kW]	FUEL	TURNDOWN RATIO	OPERATION	MAX AIR EXCESS	FLAME DIAMETER [mm]	FLAME LENGHT [mm]	GAS SUPPLY PRESSURE [mbar]	AIR SUPPLY PRESSURE [mbar]	WEIGHT [kg]
BPR 75	5-87	Natural gas and LPG	18:1	Modulating	50% at 87 kW	160	600	30	8	22
BPR 150	6-175	Natural gas and LPG	30:1	Modulating	50% at 175 kW	200	600	10	10	38
BPR 300	9-350	Natural gas and LPG	40:1	Modulating	50% at 350 kW	250	600	40	10	45
BPR 450	18-525	Natural gas and LPG	30:1	Modulating	50% at 325 kW	300	600	20	10	48
BPR 600	18-700	Natural gas and LPG	25:1	Modulating	50% at 700 kW	350	700	35	17	48
BPR 800	18-930	Natural gas and LPG	50:1	Modulating	50% at 930 kW	350	1000	35	17	52
BPR 1200	30-1450	Natural gas and LPG	30:1	Modulating	50 % at 1450 kW	350	1200	35	17	56

The above data refer to maximum power conditions. The pressure values are approximate, the gas values refer to Natural Gas.
 Flame dimensions are referred to 30% air excess condition
 Performance data and dimensions are guidelines only.
 Other versions are available on demand by means a special execution request.

Industrial combustion system data sheets section

INDUSTRIAL BURNERS

pag 733

SYSTEM COMPONENTS

pag 749

HEATING PUMPING UNITS

pag 749

PRESSURE REGULATING / REDUCING UNITS

SAFETY / REGULATING GAS TRAINS

pag 749

SAFETY / REGULATING PROPORTIONAL GAS TRAINS

CENTRIFUGAL AIR FANS

pag 767

BURNER CONTROL PANELS

pag 769

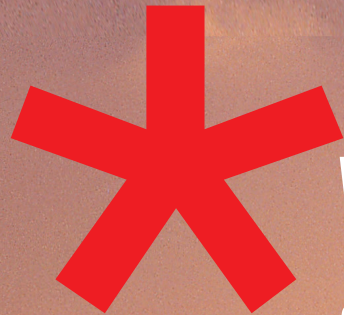

We are here
energizing your working
environment and processes



RIELLO

www.riello.com

DB SERIES

The new DB burners range represents the evolution in Riello Burners industrial product range.

They are dual block burners for application in big plants (district heating, hospitals) as well as in food, chemicals, textile industry for matching with hot water boilers, steam and thermal oil generators.

DB series burners can be supplied with electronic or mechanical air-fuel ratio control according to customer specification.

DB 9-12-16-20 are equipped with pilot ignition, while for DB 4-6 models it can be supplied on demand. DB series can work with pre-heated air up to 150°C as standard, up to 250°C with special construction. New variable geometry combustion head allows to reach < 80 mg/kWh NOx emission on natural gas operations.

An hinge system for easier combustion head maintenance is available on all models.

As part of the offer, various accessories (air fan, control panels, high pressure gas train, etc) are available.

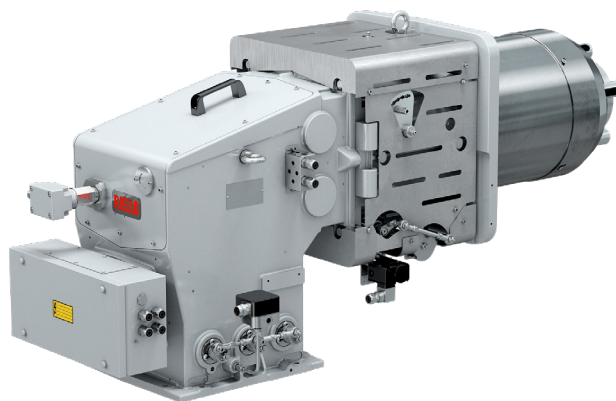

DB 4	1000/2500 ÷	5000 kW
DB 6	1400/4000 ÷	7800 kW
DB 9	1500/5000 ÷	9500 kW
DB 12	1700/7000 ÷	12500 kW
DB 16	3000/10000 ÷	16000 kW
DB 20	3000/10000 ÷	20000 kW

Industrial Dual Block Oil, Gas and Dual Fuel Burners

DB SERIES

FIRING RATES

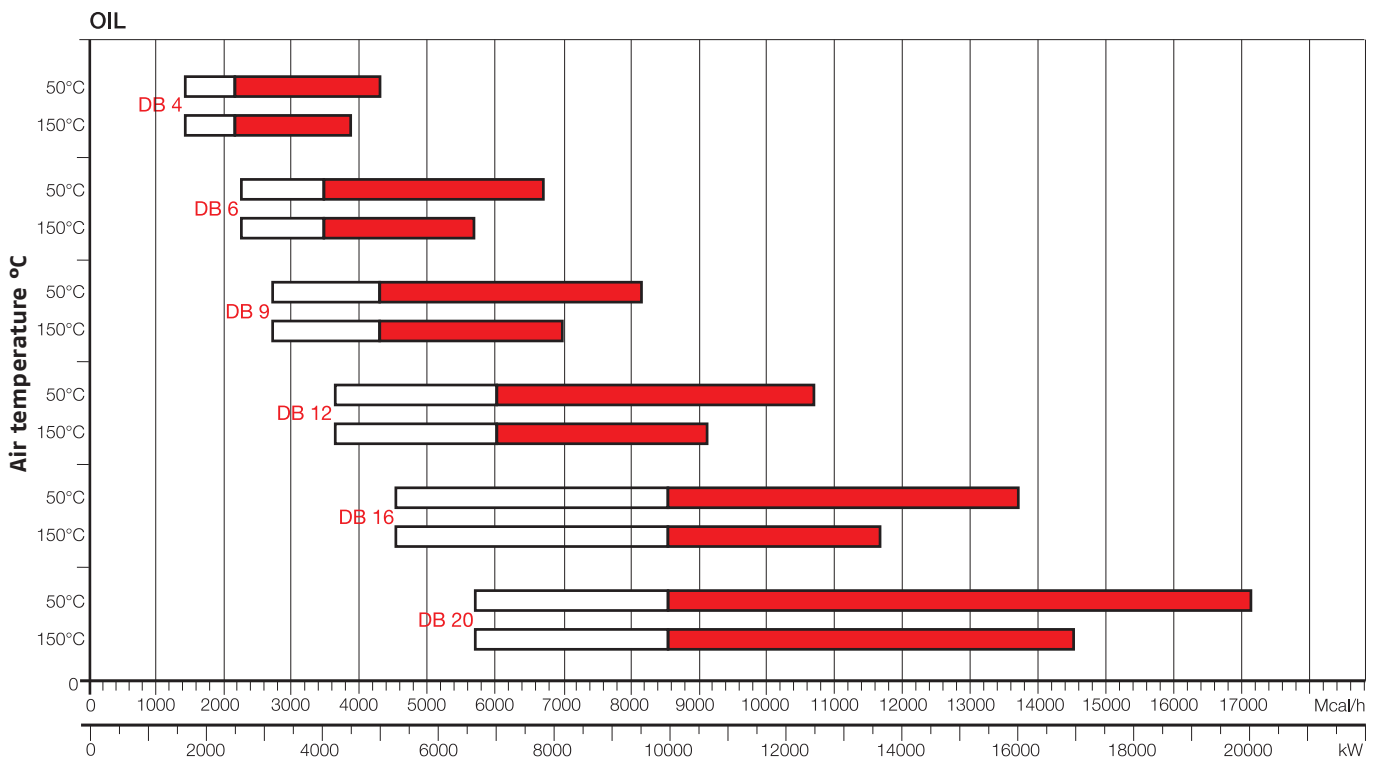
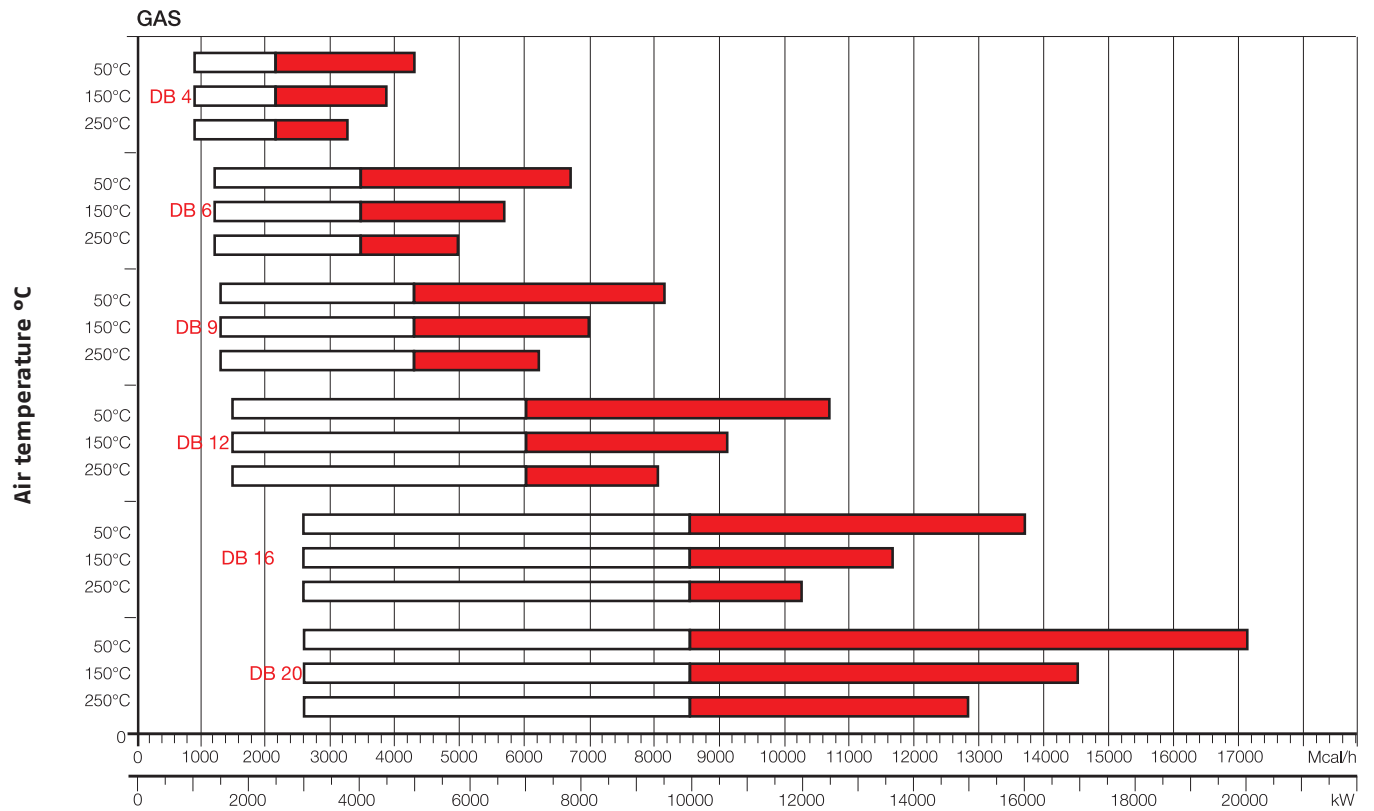

Modulation range Working field

Test conditions conforming to EN 267- EN676

Temperature: 20°C

Pressure: 1013.5 mbar

Altitude: 100 m a.s.l.

For high air temperature applications, higher than 150°C, a special burner execution is required.

DB SERIES

Overall dimensions (mm)

BURNER

The burner drawings below are referred to the low NOx version.

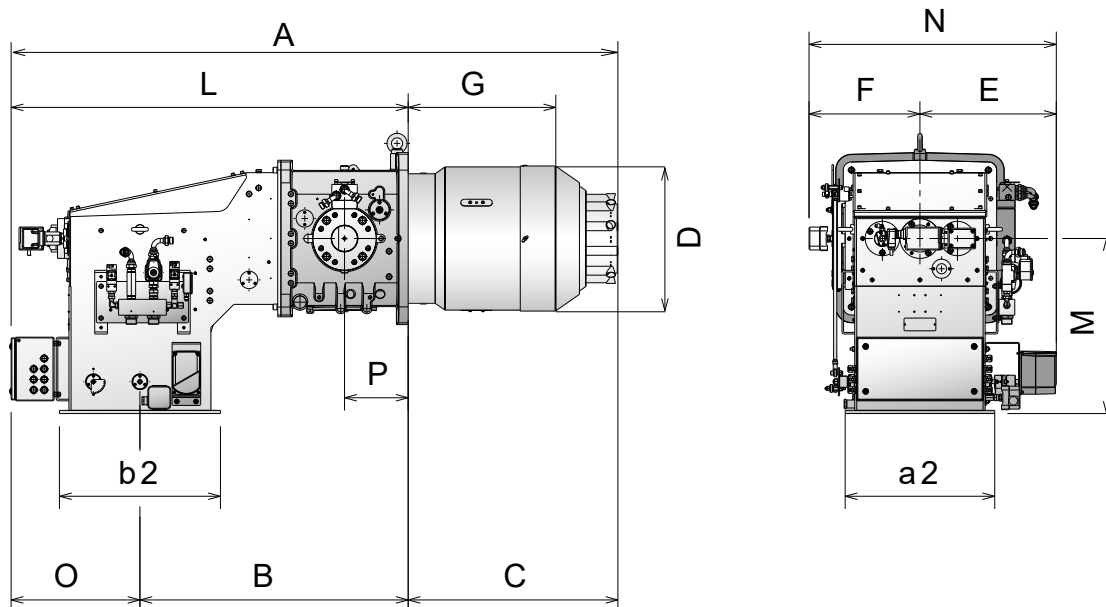

MODEL	A	B	C	D	E	F	G	L	M	N	O	P
▶ DB 4 SM C03	1530	655	536	313	275	453	370	1009	450	728	341	183
▶ DB 6 SM C03	1582	670	521	363	275	460	400	1024	450	728	341	183
▶ DB 9 SM C03	1911	843	669	413	566	360	484	1242	550	926	344	200
▶ DB 12 SM C03	1911	843	669	456	579	337	463	1242	550	916	344	200
▶ DB 16 SM C03	2245	852	797	544	448	375	540	1242	761	934	431	250
▶ DB 20 SM C03	2003	851	797	590	448	375	561	1393	761	934	431	258

L = gas version

a2 - b2 = see "Burner-boiler mounting flange" dimensions table

All dimensions are approximate and mentioned just as an indication. Please refer to Riello Burners Technical Department for further detailed information.

GAS CONNECTIONS

DB 4: DN 65
DB 6: DN 80

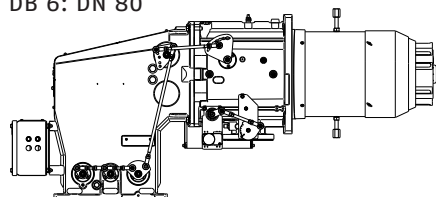

DN 65 gas connection from below
Elbow adapter DN 65 required
DN 80 gas connection from below (for gas versions). Elbow adapter DN 80 required.

DB 9 - 12

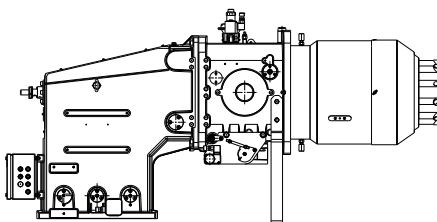

DN 80 gas connection from below (for gas versions). Elbow adapter DN 80 required.

DB 16 - 20

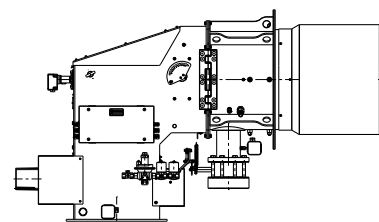

DN 100 gas connection from the side
Elbow 100/100 adapter already included as standard equipment

DB SERIES

Overall dimensions (mm)

BURNER - BOILER MOUNTING FLANGE

AIR DUCT CONNECTION

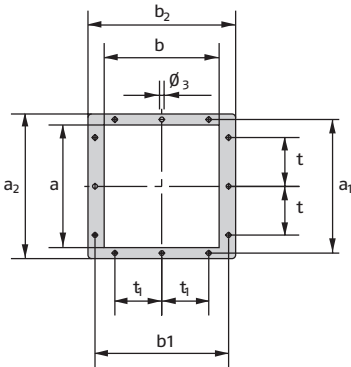

FIXING TO THE BOILER

DB 4 - 6 - 9 - 12

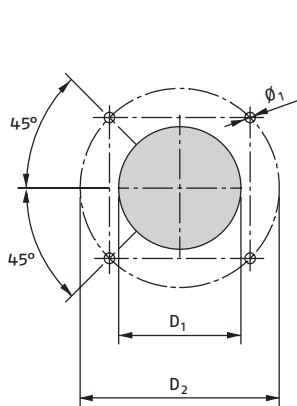

DB 16 - 20

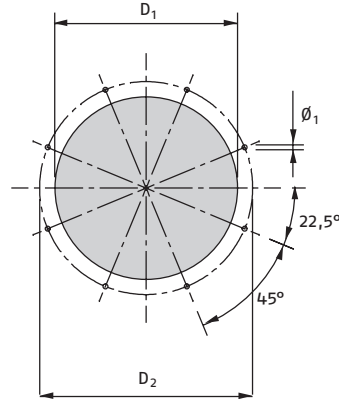

GAS SUPPLY

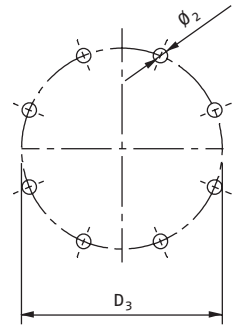

MODEL	a	a ₁	a ₂	b	b ₁	b ₂	D ₁	D ₂	D ₃	t	t ₁	Ø ₁	Ø ₂	Ø ₃
▶ DB 4	329	370	400	308	370	409	350	452	145 - DN 65	130	130	M18	4x45°M16	13
▶ DB 6	329	370	400	308	370	409	380	495	160 - DN80	130	130	M18	M16	13
▶ DB 9	436	476	506	400	440	470	420	608	160 - DN 80	200	180	M20	M18	11
▶ DB 12	436	476	506	400	440	470	465	608	160 - DN 80	200	180	M20	18	11
▶ DB 16	562	620	652	452	510	542	560	700	180 - DN 100	260	205	M16	18	11
▶ DB 20	562	620	652	452	510	542	600	700	160 - DN 100	260	205	M16	18	11

PACKAGING

Overall dimensions and weights to estimate the delivery.

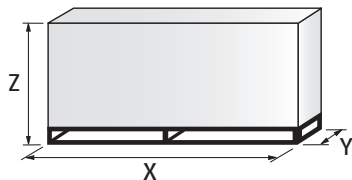

MODEL	X	Y	Z	kg
▶ DB 4	2100	1000	1200	200
▶ DB 6	2040	1180	1125	200
▶ DB 9	2040	1180	1125	270
▶ DB 12	2040	1180	1125	250
▶ DB 16	2200	1000	1300	530
▶ DB 20	2200	1000	1300	550

DB SERIES

Specification

DESIGNATION OF SERIES

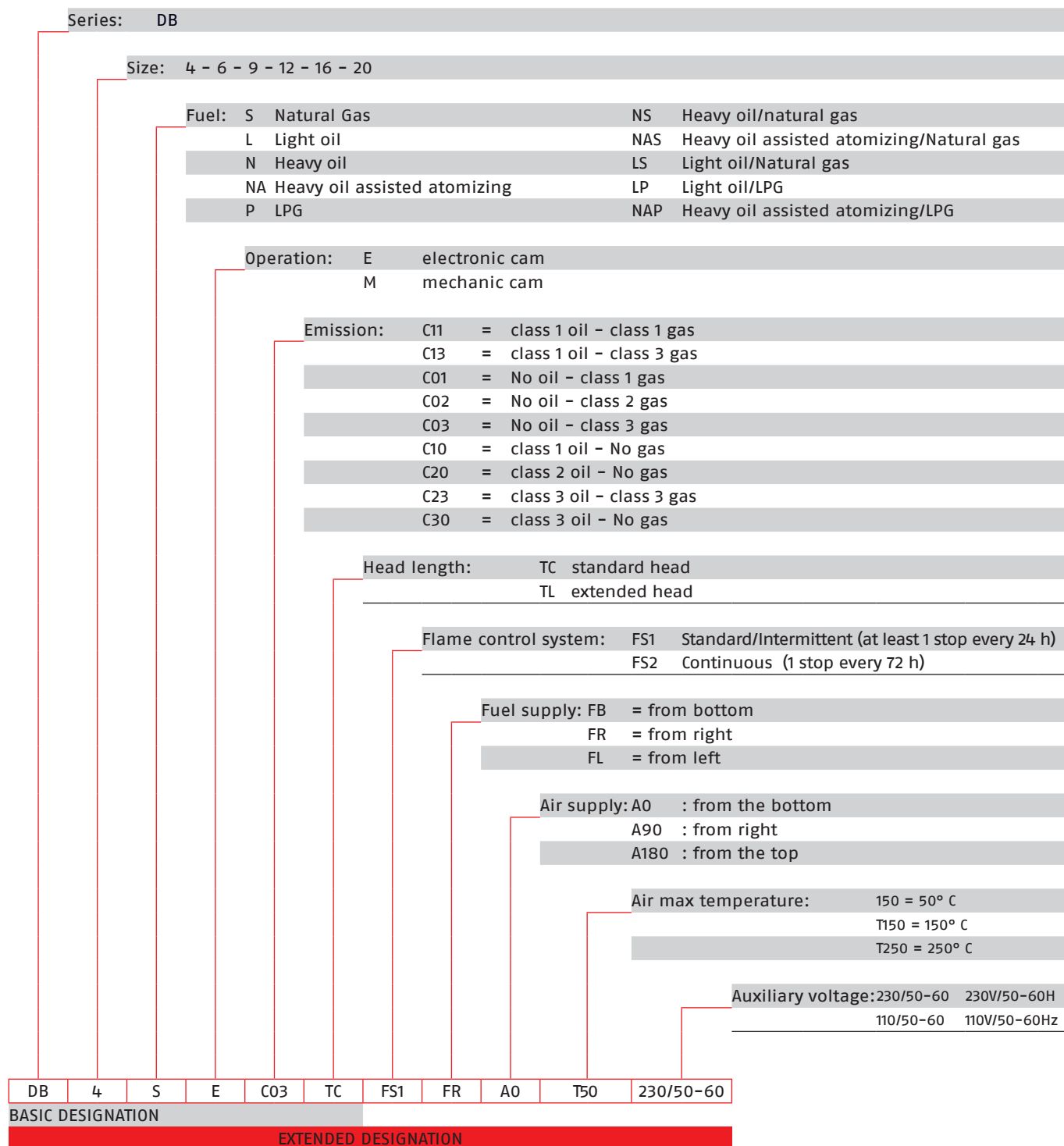

* Estimated, emissions values, considering a hot water boiler with thermal load of 1,1 MW/m³
 Guaranteed values to be confirmed after the verification of the combustion chamber characteristics

DB SERIES

Specification

DB SERIES - STATE OF SUPPLY

All burners

Dual block forced draught burner, two stages progressive or modulating operation (with a kit), separate supply, fully automatic, made up of:

- Air damper for air setting with variable profile cam controlled by a servomotor (version /M – mechanical cam)
- Air damper for air setting with air servomotor managed by microprocessor (version /E – electronic cam)
- Variable geometry combustion head that can be set according to the required output
- Combustion head servomotor managed by microprocessor (version /E – electronic cam DB16-20 only)
- Pilot burner with two gas valves and pressure regulator (as standard on DB9-12-16-20 only)
- Minimum air pressure switch
- Flame inspection window
- Electrical interface box with ignition transformer inside
- Opening hinge to have easier combustion head inspection and maintenance
- IP54 protection level.

Oil Burner

- Photocell for flame detection
- Nozzle pipe
- Safety nozzle valve
- Oil lance without nozzle (nozzle must be ordered separately)
- Valves group with safety oil valves
- Oil capacity regulator controlled by air servomotor linkage (version /M – mechanical cam)
- Oil capacity regulator with servomotor managed by microprocessor (version /E – electronic cam)
- Maximum oil pressure switch on the return circuit
- Pressure gauge on delivery and return circuit.

Standard equipment:

- screws for fixing the burner flange to the boiler
- thermal screen
- instruction handbook for installation, use and maintenance
- spare parts catalogue.

Gas Burner

- Photocell for flame detection
- Maximum gas pressure switch
- Butterfly gas valve controlled by air servomotor linkage (version /M – mechanical cam)
- Butterfly gas valve with servomotor managed by microprocessor (version /E – electronic cam)
- Gas pressure test point to the combustion head.

Standard equipment:

- screws for fixing the burner flange to the boiler
- thermal screen
- screws for fixing the gas train flange to the burner
- gas train gasket
- high voltage burner ignition for DB 4÷6
- pilot burner ignition for DB 9÷20 (for DB 4÷6 on demand)
- instruction handbook for installation, use and maintenance
- spare parts catalogue.

DB SERIES

Specification

DB SERIES - STATE OF SUPPLY

Dual fuel Burner (Oil/Gas)

- Photocell for flame detection
- Nozzle pipe
- Safety nozzle valve
- Oil lance without nozzle (nozzle must be ordered separately)
- Valves group with safety oil valves
- Oil capacity regulator controlled by air servomotor linkage (version /M – mechanical cam)
- Oil capacity regulator with servomotor managed by microprocessor (version /E – electronic cam)
- Maximum oil pressure switch on the return circuit
- Pressure gauge on delivery and return circuit
- Maximum gas pressure switch
- Butterfly gas valve controlled by air servomotor linkage (version /M – mechanical cam)
- Gas/oil servomotor managed by microprocessor (version /E – electronic cam) for butterfly gas valve / oil capacity regulator control
- Gas pressure test point to the combustion head.

Standard equipment:

- screws for fixing the burner flange to the boiler
- thermal screen
- screws for fixing the gas train flange to the burner
- gas train gasket
- high voltage burner ignition for DB 4÷6
- pilot burner ignition for DB 9÷20 (for DB 4÷6 on demand)
- instruction handbook for installation, use and maintenance
- spare parts catalogue.

Industrial Dual Block Oil, Gas and Dual Fuel Burners

DB SERIES

Models available

Burners

MODEL (1)	OPERATION	FUEL (2)	HEAT OUTPUT (3)
DB 4 S	M - E - EV	Natural Gas	1000/2500 ÷ 5000 kW
DB 6 S			1400/4000 ÷ 7800 kW
DB 9 S			1500/5000 ÷ 9500 kW
DB 12 S			1700/7000 ÷ 12500 kW
DB 16 S			3000/10000 ÷ 16000 kW
DB 20 S			3000/10000 ÷ 20000 kW
DB 4 P	M - E - EV	LPG	1000/2500 ÷ 5000 kW
DB 6 P			1400/4000 ÷ 7800 kW
DB 9 P			1500/5000 ÷ 9500 kW
DB 12 P			1700/7000 ÷ 12500 kW
DB 16 P			3000/10000 ÷ 16000 kW
DB 20 P			3000/10000 ÷ 20000 kW
DB 4 L	M - E - EV	Light Oil	1000/2500 ÷ 5000 kW
DB 6 L			1400/4000 ÷ 7800 kW
DB 9 L			1500/5000 ÷ 9500 kW
DB 12 L			1700/7000 ÷ 12500 kW
DB 16 L			3000/10000 ÷ 16000 kW
DB 20 L			3000/10000 ÷ 20000 kW
DB 4 N	M - E - EV	Heavy Oil	1000/2500 ÷ 5000 kW
DB 6 N			1400/4000 ÷ 7800 kW
DB 9 N			1500/5000 ÷ 9500 kW
DB 12 N			1700/7000 ÷ 12500 kW
DB 16 N			3000/10000 ÷ 16000 kW
DB 20 N			3000/10000 ÷ 20000 kW

(1) Further versions are available according to the variants listed at the paragraph 'Specification, Designation of Series'

(2) Dual Fuel versions are available on the basis of a combination of listed fuels

(3) Max capacity is referred to:

Light oil net calorific value 11,8 kWh/kg - 10200 kcal/kg - Viscosity at 20°C 4-6 mm²/s (cSt)

Heavy oil net calorific value 11,1-11,3 kWh/kg - 9545-9720 kcal/kg - Viscosity at 20°C 500 mm²/s (cSt)

G20 net calorific value 10 kWh/Nm³ - Density 0,71 kg/Nm³

G25 net calorific value 8,6 kWh/Nm³ - Density 0,78 kg/Nm³

LPG net calorific value 25,8 kWh/Nm³ - Density 2,02 kg/Nm³

The burners of DB series can work with pre-heated air up to 150°C as standard, for high air temperature applications up to 250°C, a special burner execution is required.

For more information about product codes, please contact Riello Burners Commercial and Technical Department, our Application Engineers will be pleased to help you.

ER SERIES

The industrial burners ER series are designed especially for water tube boilers used in big civil installations and industrial processes with a remarkable thermal demand.

These burners allow to realise a modular and flexible combustion system adding a preparation fuel unit (regulation pressure group set, preheating/pumping oil station), a gas train, a control panel and a fan.

Preheated air can also be used as in the oil diathermic generators and other heat recovery systems.

The modulating regulation always allows to reach a wide modulation ratio and optimal fluid-dynamics conditions for a good combustion.



ER 4	540/2500 ÷	4000 kW
ER 6	840/4000 ÷	6000 kW
ER 9	1250/6000 ÷	9000 kW
ER 12	1750/9000 ÷	12000 kW
ER 16	2350/12000 ÷	16000 kW
ER 20	3000/16000 ÷	20000 kW
ER 25	3500/20000 ÷	25000 kW
ER 32	4000/25000 ÷	32000 kW

Industrial Oil, Gas and Dual Fuel Air Register Burners

ER SERIES

FIRING RATES

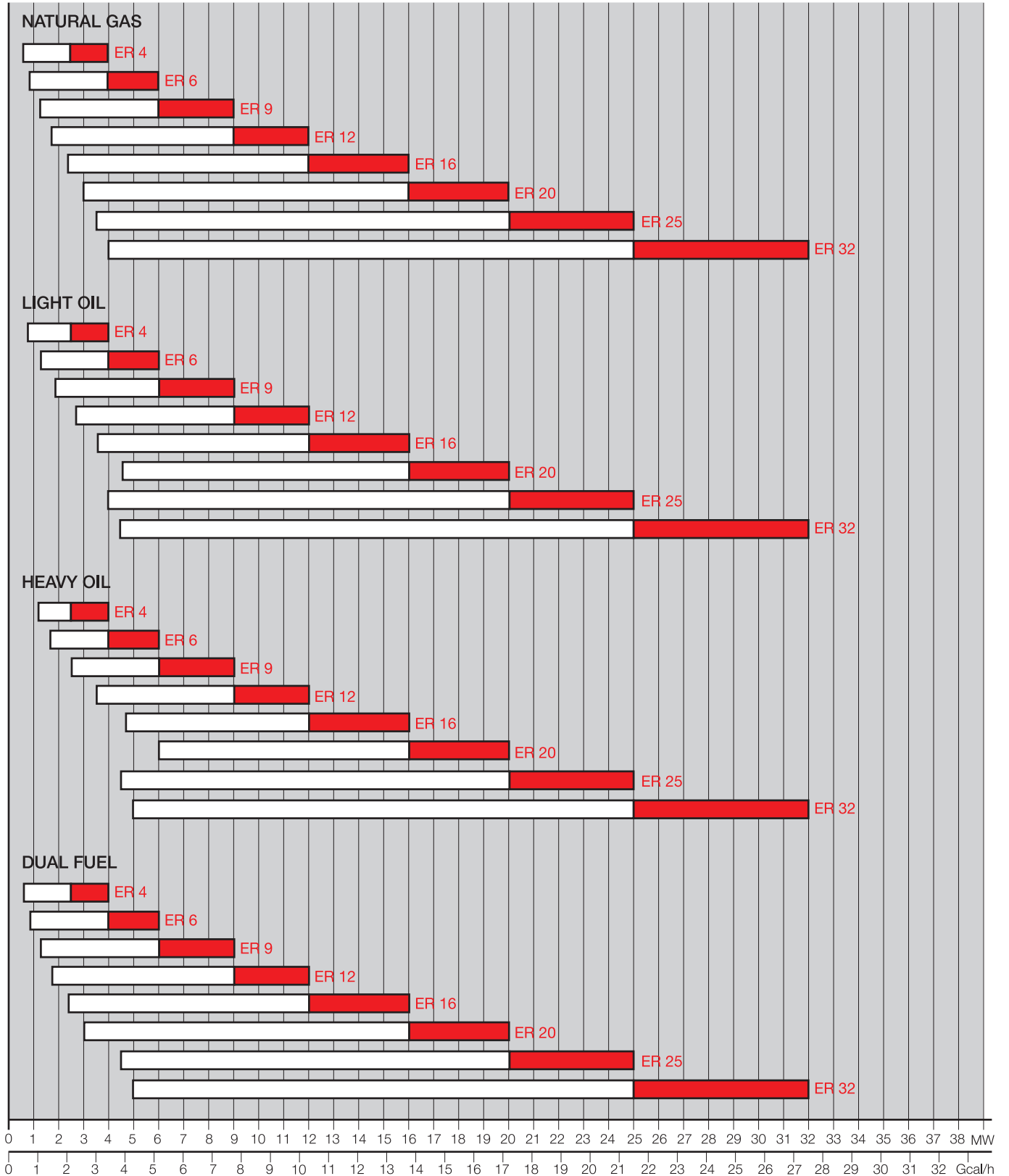

Test conditions conforming to EN 267 - EN 676:
 Temperature: 20°C - Pressure: 1013,5 mbar - Altitude: 0 m a.s.l.

Modulation range Working field

ER SERIES

Overall dimensions (mm)

BURNER

ER 4 - 6 - 9 - 12

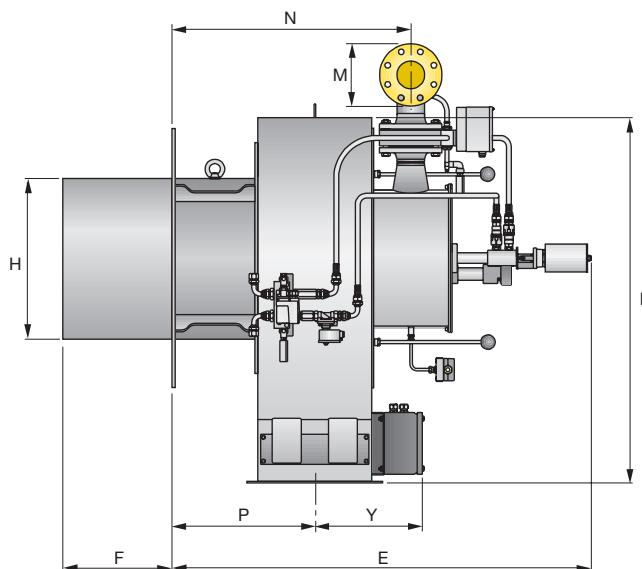
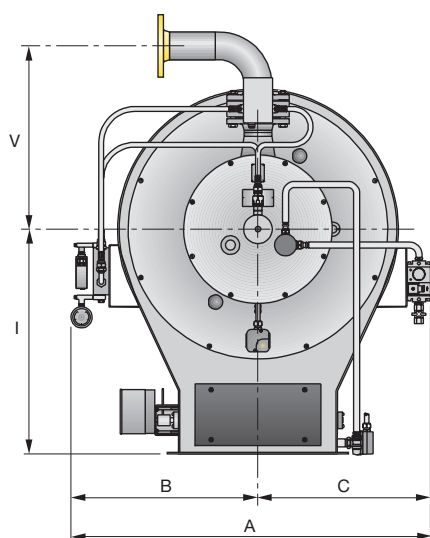

ER 16 - 20 - 25 - 32

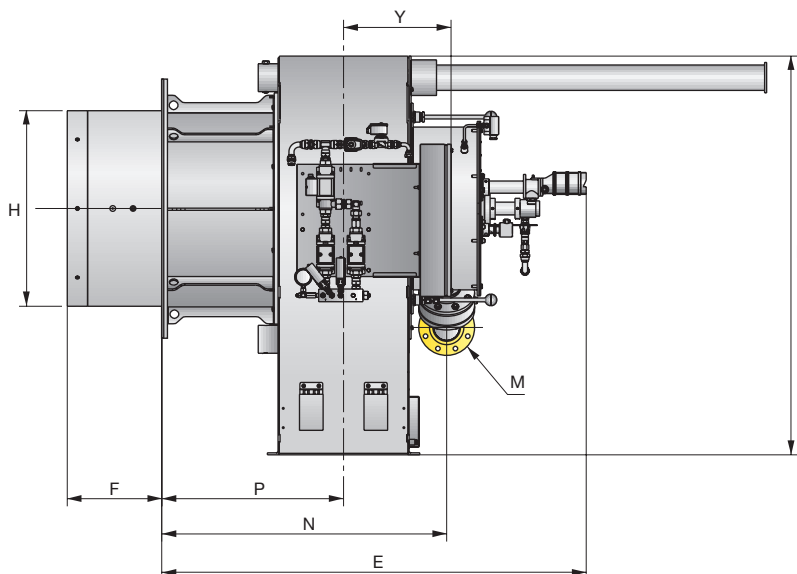
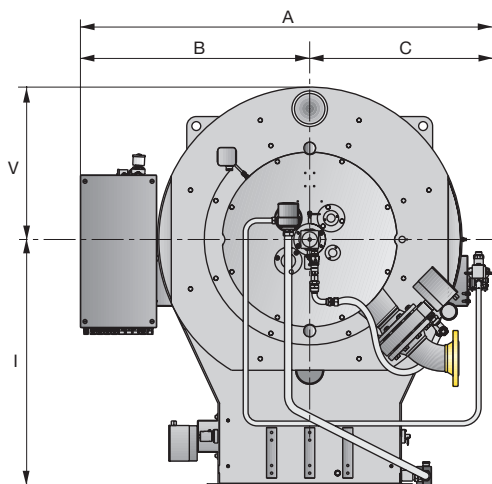

All dimensions are approximate and mentioned just as an indication. Please refer to Riello Burners Technical Department for further detailed information.

MODEL	A	B	C	D	E	F	H	I	M	N	P	Y	V
▶ ER 4	855	455	400	835	1160	330	370	530	DN65	605	380	307	542
▶ ER 6	855	455	400	835	1160	330	430	530	DN65	605	380	307	542
▶ ER 9	1150	600	550	1170	1345	350	520	720	DN80	765	457	345	588
▶ ER 12	1150	600	550	1170	1345	350	600	720	DN80	765	457	345	588
▶ ER 16	1623	903	720	1570	1670	372	690	970	DN100	1122	716	423	600
▶ ER 20	1623	903	720	1570	1670	372	770	970	DN100	1122	716	423	600
▶ ER 25	1835	1007	828	1758	1952	472	870	1050	DN125	1294	794	487	708
▶ ER 32	1835	1007	828	1758	1952	472	980	1050	DN125	1294	794	487	708

Overall dimensions (mm)

BURNER - BOILER MOUNTING FLANGE

AIR DUCT CONNECTION

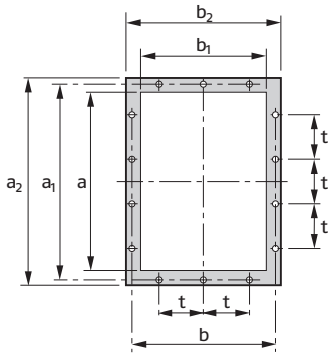

FIXING TO THE BOILER

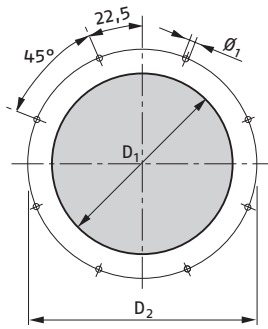

GAS SUPPLY

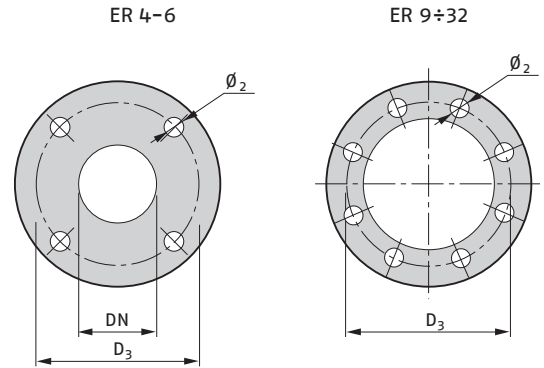

MODEL	a	a ₁	a ₂	b	b ₁	b ₂	D ₁	D ₂	D ₃	t	Ø ₁	Ø ₂
▶ ER 4	400	444	480	324	280	360	380	552	145	148	M18	18
▶ ER 6	400	444	480	324	280	360	440	552	145	148	M18	18
▶ ER 9	500	551	580	405	355	435	540	800	160	125	M18	18
▶ ER 12	500	551	580	405	355	435	620	800	160	125	M18	18
▶ ER 16	710	775	810	567	500	600	720	860	180	160	M18	18
▶ ER 20	710	775	810	567	500	600	800	970	180	160	M18	18
▶ ER 25	900	968	1018	708	640	758	930	1200	210	200	M20	18
▶ ER 32	900	968	1018	708	640	758	1050	1200	210	200	M20	18

All dimensions are approximate and mentioned just as an indication. Please refer to Riello Burners Technical Department for further detailed information.

ER SERIES

Specification

DESIGNATION OF SERIES

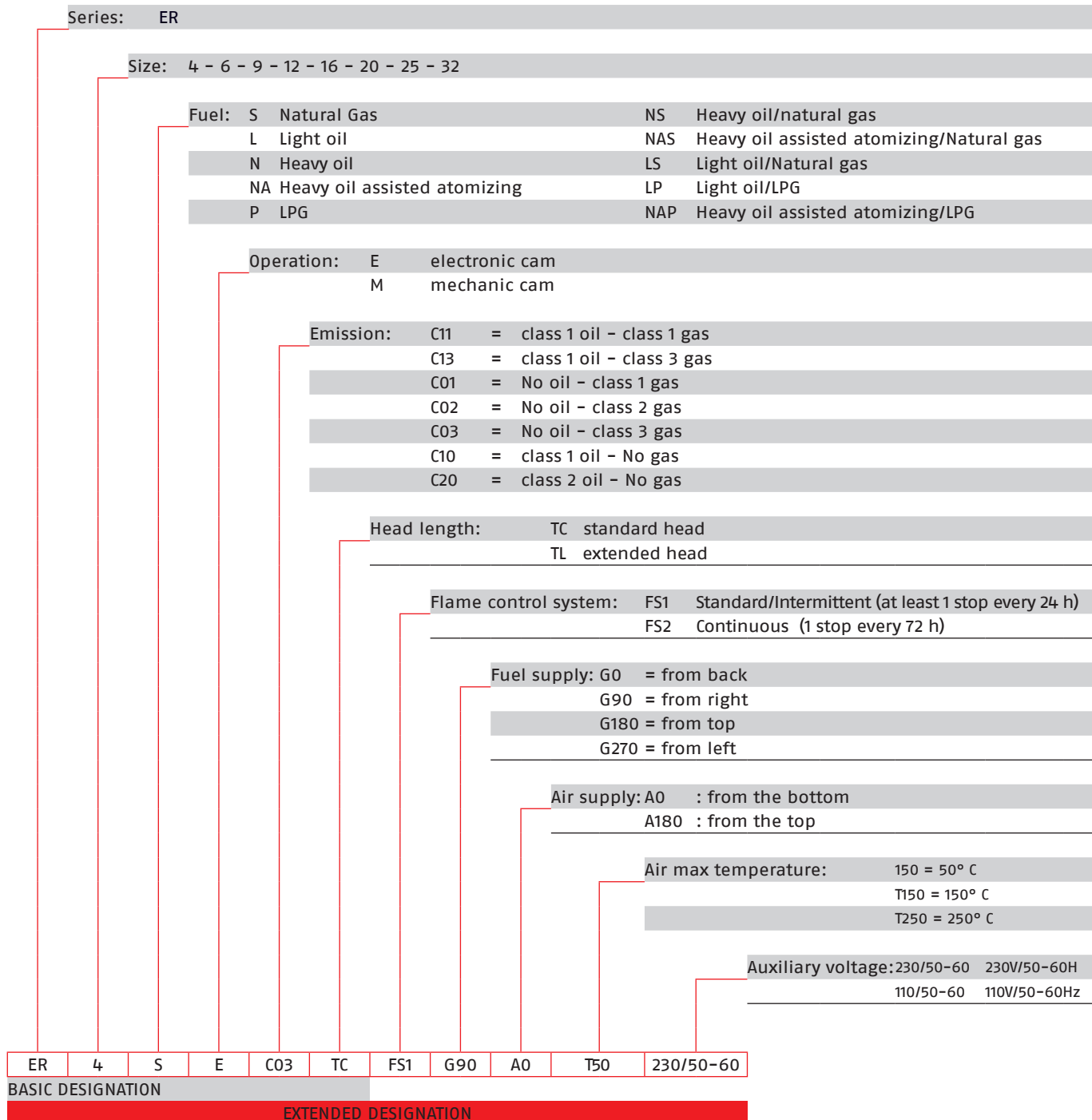

* Estimated, not guaranteed emissions values, considering a hot water boiler with thermal load of 1,1 MW/m³

Specification

STATE OF SUPPLY

Oil burner

Forced draught oil burner with modulating operation and separate supplies, fully automatic, made up of:

- Sheet-steel airlock painted with a front cover for access to the internal elements
- Air dampers for air setting controlled by two independent high precision servomotors
- Combustion head fitted with:
 - stainless steel end cone, resistant to corrosion and high temperatures
 - pilot burner with gas train and ignition electrodes
 - flame stability disk made up of axial swirlers
- Flame shape regulation device
- Photocell for flame detection
- Minimum air pressure switch
- Nozzle pipe
- Safety nozzle valve
- Valves group with safety oil valves
- Automatic regulator of oil delivery controlled by a high precision servomotor
- Maximum oil pressure switch on the return circuit
- Pressure gauge on the delivery circuit
- Pressure gauge on the return circuit
- Electrical box with ignition transformer
- IP 54 electric protection level.

Standard equipment:

- Screws for fixing the burner flange to the boiler
- Thermal screen
- Instruction handbook for installation, use and maintenance
- Spare parts catalogue.

Gas burner

Forced draught gas burner with modulating operation and separate supplies, fully automatic, made up of:

- Sheet-steel airlock painted with a front cover for access to the internal elements
- Air dampers for air setting controlled by two independent high precision servomotors
- Combustion head fitted with:
 - stainless steel end cone, resistant to corrosion and high temperatures
 - gas distributor with multiple pipes
 - pilot burner with gas train and ignition electrode and probe
 - uv photocell
 - flame stability disk made up of axial swirler
- Flame shape regulation device
- Minimum air pressure switch
- Maximum gas pressure switch
- Automatic regulator for gas delivery, controlled by a high precision servomotor
- Gas pressure test point to the combustion head
- Electrical box with ignition transformer
- IP 54 electric protection level.

Standard equipment:

- Screws for fixing the burner flange to the boiler
- Thermal screen
- Screws for fixing the gas train flange to the burner
- Gas train gasket
- Instruction handbook for installation, use and maintenance
- Spare parts catalogue.

ER SERIES

Specification

STATE OF SUPPLY

Dual fuel burner (oil/gas)

Forced draught dual fuel burner with modulating operation and separate supplies, fully automatic, made up of:

- Sheet-steel airlock painted with a front cover for access to the internal elements
- Air dampers for air setting controlled by two independent high precision servomotors
- Combustion head fitted with:
 - stainless steel end cone, resistant to corrosion and high temperatures
 - gas distributor with multiple pipes
 - pilot burner with gas train and ignition electrode and probe
 - flame stability disk made up of axial swirler
- Flame shape regulation device
- UV photocell for flame detection
- Nozzle pipe
- Safety nozzle valve
- Valves group with safety oil valves
- Automatic regulator of oil and gas delivery controlled by a high precision servomotor
- Maximum oil pressure switch on the return circuit
- Pressure gauge on the delivery circuit
- Pressure gauge on the return circuit
- Minimum air pressure switch
- Maximum gas pressure switch
- Gas pressure test point to the combustion head
- Electrical box with ignition transformer
- IP 54 electric protection level.

Standard equipment:

- Screws for fixing the burner flange to the boiler
- Thermal screen
- Screws for fixing the gas train flange to the burner
- Gas train gasket
- Instruction handbook for installation, use and maintenance
- Spare parts catalogue.

Industrial Oil, Gas and Dual Fuel Air Register Burners

ER SERIES

Models available

Burners

MODEL (1)	Operation	FUEL (2)	HEAT OUTPUT (3)
ER 4 S	M - E	Natural Gas	540/2500 ÷ 4000 kW
ER 6 S			840/4000 ÷ 6000 kW
ER 9 S			1250/6000 ÷ 9000 kW
ER 12 S			1750/9000 ÷ 12000 kW
ER 16 S			2350/12000 ÷ 16000 kW
ER 20 S			3000/16000 ÷ 20000 kW
ER 25 S			3500/20000 ÷ 25000 kW
ER 32 S			4000/25000 ÷ 32000 kW
ER 4 P	M - E	LPG	540/2500 ÷ 4000 kW
ER 6 P			840/4000 ÷ 6000 kW
ER 9 P			1250/6000 ÷ 9000 kW
ER 12 P			1750/9000 ÷ 12000 kW
ER 16 P			2350/12000 ÷ 16000 kW
ER 20 P			3000/16000 ÷ 20000 kW
ER 25 P			3500/20000 ÷ 25000 kW
ER 32 P			4000/25000 ÷ 32000 kW
ER 4 L	M - E	Light Oil	540/2500 ÷ 4000 kW
ER 6 L			840/4000 ÷ 6000 kW
ER 9 L			1250/6000 ÷ 9000 kW
ER 12 L			1750/9000 ÷ 12000 kW
ER 16 L			2350/12000 ÷ 16000 kW
ER 20 L			3000/16000 ÷ 20000 kW
ER 25 L			3500/20000 ÷ 25000 kW
ER 32 L			4000/25000 ÷ 32000 kW
ER 4 N	M - E	Heavy Oil	540/2500 ÷ 4000 kW
ER 6 N			840/4000 ÷ 6000 kW
ER 9 N			1250/6000 ÷ 9000 kW
ER 12 N			1750/9000 ÷ 12000 kW
ER 16 N			2350/12000 ÷ 16000 kW
ER 20 N			3000/16000 ÷ 20000 kW
ER 25 N			3500/20000 ÷ 25000 kW
ER 32 N			4000/25000 ÷ 32000 kW

(1) Further versions are available according to the variants listed at the paragraph 'Specification, Designation of Series'

(2) Dual Fuel versions are available on the basis of a combination of listed fuels

(3) Max capacity is referred to:

Light oil net calorific value 11,8 kWh/kg - 10200 kcal/kg - Viscosity at 20°C 4-6 mm²/s (cSt)

Heavy oil net calorific value 11,1-11,3 kWh/kg - 9545-9720 kcal/kg - Viscosity at 20°C 500 mm²/s (cSt)

G20 net calorific value 10 kWh/Nm³ - Density 0,71 kg/Nm³

G25 net calorific value 8,6 kWh/Nm³ - Density 0,78 kg/Nm³

LPG net calorific value 25,8 kWh/Nm³ - Density 2,02 kg/Nm³

For more information about product codes, please contact Riello Burners Commercial and Technical Department, our Application Engineers will be pleased to help you.

SG and DG SERIES SN and DN SERIES

The unit skids of SG, DG, SN and DN series to treat and prepare fuel are an integral part of the industrial burners. The system, designed for oil fuel with max viscosity 65°E at 50°C, consists mainly of a filter, a heater, a pump and a vent valve. Electric or steam/electric heaters may be used and a double system with backup filter and pump is also available.

The unit skids come ready assembled and tested for fast installation and the wide range of models available makes the system suitable for many different application.



SG and DG series	250 ÷ 2000 kg/h	set at 28 bar
SGA/DGA series	300 ÷ 2000 kg/h	set at 10 bar for assisted atomization
SN/DN series	250 ÷ 2100 kg/h	set at 30 bar
SNA/DNA series	350 ÷ 2200 kg/h	set at 10 bar for assisted atomization

Light Oil Pumping Unit Skids - Heavy Oil Heating and Pumping Unit Skids for Industrial Burners

SG and DG SERIES - SN and DN SERIES

Specification

DESIGNATION OF SERIES

Series:	S	single pump and single filter skid
	D	double pump and double filter skid
Fuel:	G	Light oil
	K	Kerosene
	N	Heavy oil
Pressure:	low range pressure	
Type :	160 - 250 - 320 - 400 - 500 - 650 - 800 - 1000 - 1200 - 1500 - 2000	
Heating type:	EP	electrical heating
	EV	mixed heating: electrical/ steam
	V	steam heating
	AS	superheated water heating
Electrical connection:	SB	shunt box
	SC	direct connection (standard)
Electrical supply:	3/400/50	3/440/60 3/380/60
		3/220/60
Control circuit electrical:	230/50-60 Hz	
	110/50-60 Hz	
Installation:	I	internal
	O	external

R	S	A	500	EV	SB	3/400/50	230/50-60	I
BASIC DESIGNATION					EXTENDED DESIGNATION			

STATE OF SUPPLY

- Base on paint steel sheet
- Manual shut-off valve
- Selfcleaning filter on SN skids and cartridge filter on SG skids
- Gas separator group
- Pressure regulator on the burner oil circuit
- Pumping group
- Pressure gauge
- Electrical heater (on the EP models)
- Mixed heating: electrical/steam (on the EV models)
- Maximum thermostat
- Minimum thermostat
- Shunt box
- Steam circuit solenoid valve
- Temperature probe
- Safety valve
- Heating cartridge.

SG and DG SERIES - SN and DN SERIES

Available models

MODEL	FUEL	PORT SIZE IN	PORT SIZE OUT	PUMP DELIVERY *l/h	PUMP MOTOR kW	SKID DELIVERY **kg/h
SG 250	Light-oil	G1/2"	G1/2"	600	1,1	250
SG 320	Light-oil	G1/2"	G1/2"	800	1,5	350
SG 500	Light-oil	G1/2"	G1/2"	1200	2,2	520
SG 800	Light-oil	G3/4"	G3/4"	1700	3,0	800
SG 1000	Light-oil	G1"	G3/4"	2200	4,0	950
SG 1500	Light-oil	G1"	G1"	3600	5,5	1500
SG 2000	Light-oil	G1"1/4	G1"	4800	7,5	2000

* these data are referred at 50Hz and pump pressure factory set at 28 bar

** Max. oil delivery of Skid considering a safety increase of 100%, oil density 0,86

MODEL	FUEL	PORT SIZE IN	PORT SIZE OUT	"PUMP DELIVERY *l/h	PUMP MOTOR kW	SKID DELIVERY **kg/h
SGA 320	Light-oil	G1/2"	G1/2"	450	0,37	310
SGA 500	Light-oil	G1/2"	G1/2"	700	0,75	480
SGA 800	Light-oil	G3/4"	G3/4"	1000	1,5	690
SGA 1000	Light-oil	G1"	G3/4"	1500	2,2	1000
SGA 1500	Light-oil	G1"	G1"	2000	3,0	1380
SGA 2000	Light-oil	G1"1/4	G1"	3000	5,5	2070

* these data are referred at 50Hz and pump pressure factory set at 28 bar

** Max. oil delivery of Skid considering a safety increase of 20%, oil density 0,86

MODEL	FUEL	PORT SIZE IN	PORT SIZE OUT	PUMP DELIVERY *l/h	PUMP MOTOR kW	HEATING POWER kW	SKID DELIVERY **kg/h
SN 250 EP	Heavy-oil	G1/2"	G1/2"	600	1,5	14	250
SN 320 EP	Heavy-oil	G1/2"	G1/2"	700	1,5	20	350
SN 650 EP	Heavy-oil	G1/2"	G1/2"	1200	2,2	28	600
SN 800 EP	Heavy-oil	G3/4"	G3/4"	1700	3,0	40	850
SN 1000 EP	Heavy-oil	G1"	G3/4"	2200	4,0	60	1100
SN 1500 EP	Heavy-oil	G1"	G1"	3600	5,5	80	1700
SN 2000 EP	Heavy-oil	G1"1/4	G1"	4800	7,5	100	2100

* these data are referred at 50Hz and pump pressure factory set at 30 bar

** Max. oil delivery of Skid considering a safety increase of 100% and an heating increase of 80°C, oil density 0,98

MODEL	FUEL	PORT SIZE IN	PORT SIZE OUT	PUMP DELIVERY *l/h	PUMP MOTOR kW	HEATING POWER kW	SKID DELIVERY **kg/h
SNA 320 EP	Heavy-oil	G1/2"	G1/2"	450	0,37	14	350
SNA 500 EP	Heavy-oil	G1/2"	G1/2"	700	0,75	20	560
SNA 800 EP	Heavy-oil	G3/4"	G3/4"	1000	1,5	28	800
SNA 1200 EP	Heavy-oil	G1"	G3/4"	1500	2,2	40	1200
SNA 1600 EP	Heavy-oil	G1"	G1"	2000	3,0	56	1600
SNA 2200 EP	Heavy-oil	G1"1/4	G1"	3000	4	80	2200

* these data are referred at 50Hz and pump pressure factory set at 10 bar

** Max. oil delivery of Skid considering a safety increase of 20% and an heating increase of 60°C, oil density 0,98

For more information about product codes, please contact Riello Burners Commercial and Technical Department, our Application Engineers will be pleased to help you.

HPRT SERIES
CB SERIES
MBC SERIES
VGD SERIES
DMV SERIES

Pressure reduction and regulation units allow to bring gas pressure available in the line to values suited to the specific application.

Gas trains include a series of safety and control devices for gas feeding to the burner.

They are constructed and supplied with two different selection options (separated or assembled units). The selection has to be made on the specific application (available pressure, installation chances,...).

This permits to reach the best flexibility using pre-assembled units, which are also tested in the factory according with existing norms and designed for a easy installation.

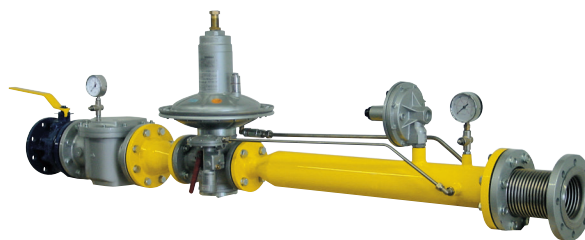

HPRT	Pin = 0,5 ÷ 4	bar
CB	Pin ≤ 0,5	bar
MBC	Pin ≤ 0,5	bar (≤ 0,36 threaded)
VGD	Pin ≤ 0,5	bar
DMV	Pin ≤ 0,5	bar

Gas Trains

HPRT - CB - MBC - VGD - DMV SERIES

Overall dimensions (mm)

HIGH PRESSURE REGULATING / REDUCING UNITS (HPRT series)

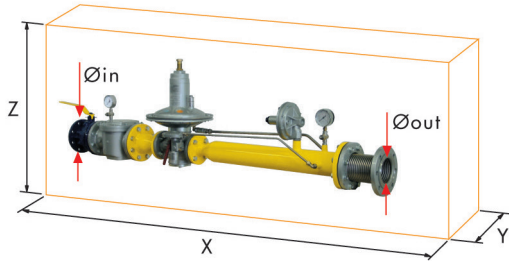

MODEL	X	Y	Z	Ø IN	Ø OUT
▶ HPRT 80	625	120	250	Rp 1	Rp 1
▶ HPRT 180	1255	230	400	Rp 1 1/2	Rp 2
▶ HPRT 250	1340	230	400	Rp 2	Rp 2
▶ HPRT 500	1730	230	400	DN 65	DN 65
▶ HPRT 750	1900	350	550	DN 80	DN 80
▶ HPRT 1000	2220	350	550	DN 100	DN 100
▶ HPRT 1500	2220	350	550	DN 100	DN 100
▶ HPRT 2000	2630	350	550	DN 125	DN 125

SAFETY / REGULATING GAS TRAINS (CB series)

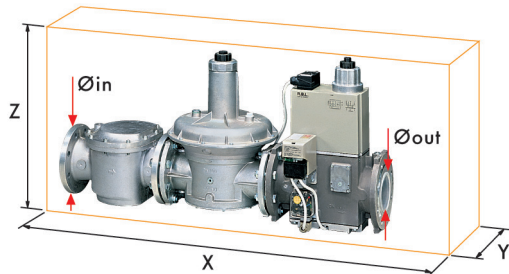

MODEL	X	Y	Z	Ø IN	Ø OUT
▶ CB 512/1 - RSM 30	891	245	261	Rp 1 1/2	Rp 1 1/2
▶ CB 520/1 - RSM 30	986	255	328	Rp 2	Rp 2
▶ CB 525/1 - RSM 30	1025	285	356	Rp 2	Rp 2
▶ CB 5065/1 - FSM 30	906	285	356	DN 65	DN 65
▶ CB 5080/1 - FSM 30	934	285	416	DN 80	DN 80
▶ CB 50100/1 - FSM 30	1054	350	501	DN 100	DN 100
▶ CB 50125/1 - FSM 30	1164	400	780	DN 125	DN 125
▶ CB 512/1 CT - RSM 30	891	245	261	Rp 1 1/2	Rp 1 1/2
▶ CB 520/1 CT RSM 30	986	255	328	Rp 2	Rp 2
▶ CB 525/1 CT - RSM 30	1026	285	356	Rp 2	Rp 2
▶ CB 5065/1 CT FSM 30	906	285	356	DN 65	DN 65
▶ CB 5080/1 CT FSM 30	934	285	416	DN 80	DN 80
▶ CB 50100/1 CT FSM 30	1054	350	501	DN 100	DN 100
▶ CB 50125/1 CT FSM 30	1164	400	780	DN 125	DN 125

HPRT - CB - MBC - VGD - DMV SERIES

Overall dimensions (mm)

SAFETY / REGULATING GAS TRAINS (MBC series)

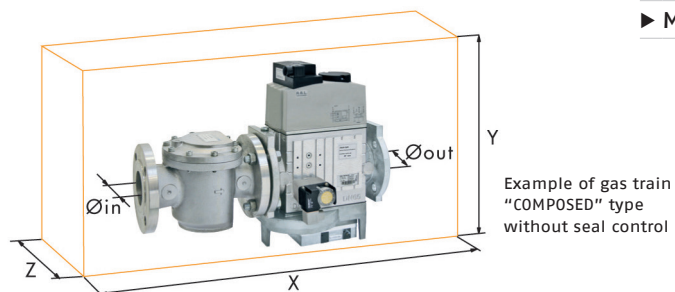
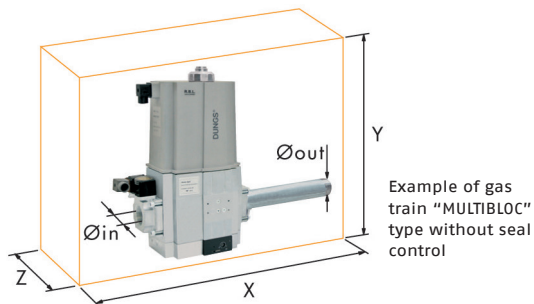

MODEL	X	Y	Z	Ø IN	Ø OUT
▶ MBC 1200/1 - RSM 60	573	425	161	2"	2"
▶ MBC 1900/1 - FSM 40	583	430	237	DN 65	DN 65
▶ MBC 3100/1 - FSM 40	633	500	240	DN 80	DN 80
▶ MBC 5000/1 - FSM 80	733	576	350	DN 100	DN 100
▶ MBC 1200/1 CT RSM 60	573	425	290	2"	2"
▶ MBC 1900/1 CT FSM 40	583	430	300	DN 65	DN 65
▶ MBC 3100/1 CT FSM 40	633	500	320	DN 80	DN 80
▶ MBC 5000/1 CT FSM 80	733	576	350	DN 100	DN 100

SAFETY / REGULATING GAS TRAINS (VGD series)

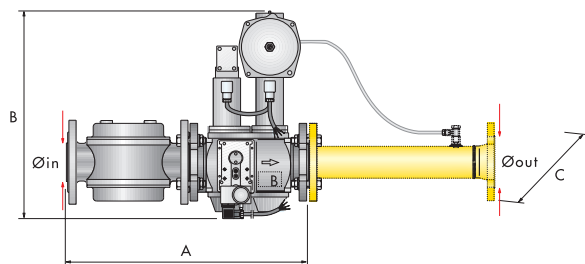

MODEL	A	B	C	Ø IN	Ø OUT
▶ VGD 50	615	495	245	2"	DN 80
▶ VGDF 65	600	520	245	DN 65	DN 80
▶ VGDF 80	625	545	245	DN 80	DN 80
▶ VGDF 100	755	575	245	DN 100	DN 80
▶ VGD 40/1	842	380	180	1" 1/2	1" 1/2
▶ VGD 50/1	880	380	194	2"	2"
▶ VGDF 65/1	1013	420	230	DN 65	DN 65
▶ VGDF 80/1	1033	450	230	DN 80	DN 80

Overall dimensions (mm)

DOUBLE SOLENOID VALVE (DMV series)

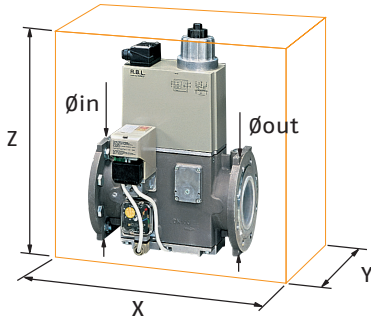

MODEL	X	Y	Z	Ø IN	Ø OUT
▶ DMV 512/1 – RSM –0	490	245	292	Rp 1 1/2	Rp 1 1/2
▶ DMV 512/1 CT RSM –0	490	245	292	Rp 1 1/2	Rp 1 1/2
▶ DMV 512/1 CQ RSM –2	490	245	292	Rp 1 1/2	Rp 1 1/2
▶ DMV 520/1 – RSM –0	490	255	292	Rp 2	Rp 2
▶ DMV 520/1 CT RSM –0	490	255	292	Rp 2	Rp 2
▶ DMV 520/1 CQ RSM –2	490	255	292	Rp 2	Rp 2
▶ DMV 525/1 – RSM –0	530	270	338	Rp 2	Rp 2
▶ DMV 525/1 CT RSM –0	530	270	338	Rp 2	Rp 2
▶ DMV 525/1 CQ RSM –2	530	270	338	Rp 2	Rp 2
▶ DMV 5065/1 – FSM –0	290	270	338	DN 65	DN 65
▶ DMV 5065/1 CT FSM –0	290	270	338	DN 65	DN 65
▶ DMV 5065/1 CQ FSM –2	290	270	338	DN 65	DN 65
▶ DMV 5080/1 – FSM –0	310	290	397	DN 80	DN 80
▶ DMV 5080/1 CT FSM –0	310	290	397	DN 80	DN 80
▶ DMV 5080/1 CQ FSM –2	310	290	397	DN 80	DN 80
▶ DMV 50100/1 – FSM –0	350	307	449	DN 100	DN 100
▶ DMV 50100/1 CT FSM –0	350	307	449	DN 100	DN 100
▶ DMV 50100/1 CQ FSM –2	350	307	449	DN 100	DN 100
▶ DMV 50125/1 – FSM –0	400	333	554	DN 125	DN 125
▶ DMV 50125/1 CT FSM –0	400	333	554	DN 125	DN 125
▶ DMV 50125/1 CQ FSM –2	400	333	554	DN 125	DN 125

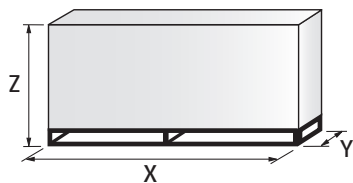
HPRT - CB - MBC - VGD - DMV SERIES**Overall dimensions (mm)****PACKAGING (HPRT - CB - MBC - VGD - DMV series)**

Model	X	Y	Z
▶ HPRT 80	890	245	260
▶ HPRT 180	1300	530	440
▶ HPRT 250	1300	530	440
▶ HPRT 500	2000	500	800
▶ HPRT 750	2000	500	800
▶ HPRT 1000	2500	500	800
▶ HPRT 1500	2500	500	800
▶ HPRT 2000	2800	500	800
▶ CB 512/1	1050	370	320
▶ CB 520/1	1050	370	320
▶ CB 5065/1	940	480	530
▶ CB 5080/1	1120	570	580
▶ CB 50100/1	1120	570	580
▶ CB 50125/1	1390	710	795
▶ MBC 1200/1	650	490	350
▶ MBC 1900/1	690	410	490
▶ MBC 3100/1	750	460	570
▶ MBC 5000/1	850	510	660
▶ VGD 50	860	360	620
▶ VGDF 65	860	360	620
▶ VGDF 80	860	360	620
▶ VGDF 100	860	360	620
▶ DMV 512/1	940	480	530
▶ DMV 520/1	940	480	530
▶ DMV 525/1	940	480	530
▶ DMV 5065/1	940	480	530
▶ DMV 5080/1	940	480	530
▶ DMV 50100/1	940	480	530
▶ DMV 50125/1	940	480	530

HPRT - CB - MBC - VGD - DMV SERIES

Specification

DESIGNATION OF SERIES

Series: HPRT high pressure regulating / reducing unit

Size: 80 - 180 - 250 - 500 - 750 - 1000 - 1500 - 2000

HPRT 180

Series: MB

MBC

VGD

CB

DMV

CG

Size:	405	407	410	412	415	420	-
	65	1200	1900	3100	5000		
	50	65	80	100	-	-	-
	512	520	525	5065	5080	50100	50125
	512	520	525	5065	5080	50100	50125
	120	220	-	-	-	-	-

Operating mode: /S = only ON-OFF function

/1 = 1 step opening

/2 = 2 steps opening

/P = 1 step opening with air/gas proportioning regulator

Valves proving system: - = non installed

CT = Valves proving system installed

CQ = Pressure Switch installed for valves proving system function

Outlet port: R = threaded

F = ISO standard flange

F1 = BS1 square flange

F2 = BS2 square flange

F3 = BS3 - BS4 square flange

Electrical connecton: T = Terminal board

SD = Domestic Plug

SM = Medium Power Plug

Standard outlet pressure range: - = without pressure regulator

0 = with regulator and air/gas proportioned pressure

2 = with regulator and outlet pressure up to 20 mbar

3 = with regulator and outlet pressure up to 30 mbar

4 = with regulator and outlet pressure up to 40 mbar

5 = with regulator and outlet pressure up to 50 mbar

6 = with regulator and outlet pressure up to 60 mbar

8 = with regulator and outlet pressure up to 80 mbar

15 = with regulator and outlet pressure up to 150 mbar

Valve driving: 0 = Common

2 = Separate

CB 5065 /1 CT F SM 3 0

HPRT - CB - MBC - VGD - DMV SERIES**Specification****STATE OF SUPPLY****HPRT series**

High pressure regulating/reducing unit, for gas of 1st - 2nd - 3rd family, with max. inlet pressure of 5 bar made up of:

- 1 manual shut-off valve (ball valve)
- 1 gas filter with filtering degree lower than 50 µm
- 1 gas pressure gauge, with shut-off push-button cock, located upstream to the regulator
- 2 connection stubs
- 1 pressure regulator-stabilizer
- 1 slam-shut valve
- 1 gas pressure gauge, with shut-off push-button cock, located downstream to the regulator
- 2 pipelines for sensing line
- 1 vent valve
- 1 antivibrating joint
- Nipples (in threaded version)
- Gaskets (in flanged version)
- Fixing screws (in flanged version).

CB series

Safety/regulating gas train for gas of 1st - 2nd - 3rd family, with MAX supply pressure of 500 mbar made up of:

- 1 gas filter with filtering degree lower than 50 µm
- 1 pressure regulator-stabilizer, for stabilizing gas inlet pressure to the burner with a $\pm 5\%$ max. tolerance respect the fixed value
- 1 valves unit composed from two automatic closing valves EN 161, class A, group 2, realized with double diaphragm technology, comprised in a single body and featured by:
 - fast closing and slow opening with adjustable fast stroke for initial gas volume
 - adjustable main delivery
 - anti-dust filter with net
- 1 minimum gas pressure switch that allows system working only with a suited pressure in the gas distribution line
- 1 automatic seal control with a release time of $10 \div 26$ seconds (when equipped)
- Nipples (in threaded version)
- Gaskets (in flanged version)
- Fixing screws (in flanged version).

MBC series

Safety shut-off valve for gas of 1st - 2nd - 3rd family, with MAX supply pressure of 360 mbar for threaded version and 500 mbar for flanged version.

Gas train are composed of:

- 1 gas filter with filtering degree lower than 50 µm (inside for the threaded valve)
- 1 valves unit composed from two automatic closing valves EN 161, class A, group 2, realized with double diaphragm technology, comprised in a single body and featured by:
 - ant-dust filter with net
 - fast closing and slow opening
- servo pressure regulator unit as per DIN EN 88 Class A Group 2
- 1 automatic seal control with a release time of $10 \div 26$ seconds (when equipped)
- Gaskets (in flanged version)
- Fixing screws (in flanged version).

Standard equipment:

- Instruction handbook for installation, use and maintenance
- Gaskets (in flanged version)
- Fixing screws (in flanged version)
- Electrical connection terminals whit plug.

Specification

STATE OF SUPPLY

VGD series

Safety shut-off valve for gas of 1st - 2nd - 3rd family, with MAX supply pressure of 500 mbar composed from:

- 1 valves unit composed from two automatic closing valves EN 161, class A, group 2, realized with double diaphragm technology, comprised in a single body and featured by:
 - fast closing and slow opening with adjustable fast stroke for initial gas volume
 - adjustable main delivery and proportional regulation
 - ant-dust filter with net
- 1 automatic seal control with a release time of 10÷26 seconds (when equipped)
- nipples (in threaded version)
- gaskets (in flanged version)
- fixing screws (in flanged version).

Standard equipment:

- instruction handbook for installation, use and maintenance
- gaskets (in flanged version)
- fixing screws (in flanged version)
- electrical connection terminals.

DMV series

Safety shut-off valve for gas of 1st - 2nd - 3rd family, with MAX supply pressure of 500 mbar composed from:

- 1 valves unit composed from two automatic closing valves EN 161, class A, group 2, realized with double diaphragm technology, comprised in a single body and featured by:
 - fast closing and slow opening with adjustable fast stroke for initial gas volume
 - adjustable main delivery and proportional regulation
 - anti-dust filter with net
- 1 automatic seal control with a release time of 10÷26 seconds (when equipped)
- nipples (in threaded version)
- gaskets (in flanged version)
- fixing screws (in flanged version).

Standard equipment:

- instruction handbook for installation, use and maintenance
- gaskets (in flanged version)
- fixing screws (in flanged version)
- electrical connection terminals.

HPRT - CB - MBC - VGD - DMV SERIES

Available models

CODE	MODEL	CONNECTION		OUTLET PRESSURE RANGE (mbar)	MAX DELIVERY PINLET = 1 BAR	MAX DELIVERY PINLET = 1 bar PINLET = 2-4 bar
		IN	OUT			
20070203	HPRT 80	Rp 1"	Rp 1"	30 ÷ 90	100	100
20069397	HPRT 180	Rp 1"1/2	Rp 2"	50 ÷ 95	250	300
20065422	HPRT 250	Rp 2"	Rp 2"	85 ÷ 180	250	380
20066448	HPRT 500	DN65	DN65	85 ÷ 180	500	650
20074024	HPRT 750	DN80	DN80	110÷200	850	850
20074026	HPRT 1000	DN100	DN100	110÷200	1000	1000
20074031	HPRT 1500	DN100	DN100	110÷200	1500	1600
20074032	HPRT 2000	DN125	DN125	110÷200	2200	2300

CODE	MODEL	Ø		PRESSURE RANGES (mbar)		NOTE
		IN	OUT	MAX INLET	OUTLET (4)	
3970145 *	CB 512/1 - RSM 30	Rp 1"1/2	Rp 1"1/2	500	10 - 30	(1)
3970146 *	CB 520/1 - RSM 30	Rp 2"	Rp 2"	500	10 - 30	(1)
20044659 *	CB 525/1 - RSM 30	Rp 2"	Rp 2"	500	10 - 30	(1)
3970147 *	CB 5065/1 - FSM 30	DN 65	DN 65	500	10 - 30	(1)
3970148 *	CB 5080/1 - FSM 30	DN 80	DN 80	500	10 - 30	(1)
3970149 *	CB 50100/1 - FSM 30	DN 100	DN 100	500	10 - 30	(1)
20015871 *	CB 50125/1 - FSM 30	DN 125	DN 125	500	10 - 30	(1)
20045589 **	CB 512/1 CT RSM 30	Rp 1"1/2	Rp 1"1/2	500	10 - 30	(2)
3970160 **	CB 520/1 CT RSM 30	Rp 2"	Rp 2"	500	10 - 30	(2)
20044660 **	CB 525/1 CT RSM 30	Rp 2"	Rp 2"	500	10 - 30	(2)
3970161 **	CB 5065/1 CT FSM 30	DN 65	DN 65	500	10 - 30	(2)
3970162 **	CB 5080/1 CT FSM 30	DN 80	DN 80	500	10 - 30	(2)
3970163 **	CB 50100/1 CT FSM 30	DN 100	DN 100	500	10 - 30	(2)
3970196 **	CB 50125/1 CT FSM 30	DN 125	DN 125	500	10 - 30	(2)
3090436 *	CB 5080/1 CQ FSM 30	DN 80	DN 80	500	10 - 30	(3)
3090327 *	CB 50100/1 CQ FSM 30	DN 100	DN 100	500	10 - 30	(3)
20010671 *	CB 50125/1 CQ FSM 30	DN 125	DN 125	500	10 - 30	(3)
3970221 *	MBC 1200/1 - RSM 60	Rp 2"	Rp 2"	360	4-60	(1)
3970222 *	MBC 1900/1 - FSM 40	DN 65	DN 65	500	20-40	(1)
3970223 *	MBC 3100/1 - FSM 40	DN 80	DN 80	500	20-40	(1)
3970224 *	MBC 5000/1 - FSM 80	DN 100	DN 100	500	40-80	(1)
3970225 **	MBC 1200/1 CT RSM 60	Rp 2"	Rp 2"	360	4-60	(2)
3970226 **	MBC 1900/1 CT FSM 40	DN 65	DN 65	500	20-40	(2)
3970227 **	MBC 3100/1 CT FSM 40	DN 80	DN 80	500	20-40	(2)
3970228 **	MBC 5000/1 CT FSM 80	DN 100	DN 100	500	40-80	(2)
3970215 *	VGD 50/P - FT 02	Rp 2"	DN 80	500	proportional	(5)
3970212 *	VGD 65/P - FT 02	Rp 2"	DN 80	500	proportional	(5)
3970213 *	VGD 80/P - FT 02	DN 65	DN 80	500	proportional	(5)
3970214 *	VGD 100/P - FT 02	DN 65	DN 80	500	proportional	(5)

* 230V/50Hz -220V/60Hz electrical supply.

** 230V/50Hz electrical supply.

(1) Seal control accessory

(2) Seal control incorporated

(3) Seal control on control panel

(4) For CB and MBC units, for different outlet pressure ranges, it is possible to match the correct springs selecting them from accessories section

(5) gas trains suitable to RS/P BLU burners only.

Available models

CODE	MODEL	CONNECTION		OUTLET PRESSURE RANGE (mbar)	MAX DELIVERY PINLET = 1 BAR	MAX DELIVERY PINLET = 1 bar PINLET = 2-4 bar
		IN	OUT			
20137712*	VGD 40/1 - RSM 02	Rp 1"1/2	Rp 1"1/2	500	0-22	(4)
20137718*	VGD 50/1 - RSM 02	Rp 2"	Rp 2"	500	0-22	(4)
20140762	VGD 65/1 - RSM 02	DN 65	DN 65	500	0-22	(4)
20140763	VGD 80/1 - RSM 08	DN 80	DN 80	500	15-120	(4)
20043035 *	DMV 512/1 - RSM -0	Rp 1" 1/2	Rp 1" 1/2	500	-	-
20043036 **	DMV 512/1 CT RSM -0	Rp 1" 1/2	Rp 1" 1/2	500	-	-
20043037 *	DMV 512/1 CQ RSM -2	Rp 1" 1/2	Rp 1" 1/2	500	-	-
20043038 *	DMV 520/1 - RSM -0	Rp 2"	Rp 2"	500	-	-
20043039 **	DMV 520/1 CT RSM -0	Rp 2"	Rp 2"	500	-	-
20043040 *	DMV 520/1 CQ RSM -2	Rp 2"	Rp 2"	500	-	-
20043053 *	DMV 525/1 - RSM -0	Rp 2"	Rp 2"	500	-	-
20043054 **	DMV 525/1 CT RSM -0	Rp 2"	Rp 2"	500	-	-
20043055 *	DMV 525/1 CQ RSM -2	Rp 2"	Rp 2"	500	-	-
20043041 *	DMV 5065/1 - FSM -0	DN 65	DN 65	500	-	-
20043042 **	DMV 5065/1 CT FSM -0	DN 65	DN 65	500	-	-
20043043 *	DMV 5065/1 CQ FSM -2	DN 65	DN 65	500	-	-
20043044 *	DMV 5080/1 - FSM -0	DN 80	DN 80	500	-	-
20043045 **	DMV 5080/1 CT FSM -0	DN 80	DN 80	500	-	-
20043046 *	DMV 5080/1 CQ FSM -2	DN 80	DN 80	500	-	-
20043047 *	DMV 50100/1 - FSM -0	DN 100	DN 100	500	-	-
20043048 **	DMV 50100/1 CT FSM -0	DN 100	DN 100	500	-	-
20043049 *	DMV 50100/1 CQ FSM -2	DN 100	DN 100	500	-	-
20043050 *	DMV 50125/1 - FSM -0	DN 125	DN 125	500	-	-
20043051 **	DMV 50125/1 CT FSM -0	DN 125	DN 125	500	-	-
20043052 *	DMV 50125/1 CQ FSM -2	DN 125	DN 125	500	-	-

* 230V/50Hz -220V/60Hz electrical supply.

** 230V/50Hz electrical supply.

(1) Seal control accessory

(2) Seal control incorporated

(3) Seal control on control panel

(4) For CB, VGD and MBC units, for different outlet pressure ranges, it is possible to match the correct springs selecting them from accessories section

(5) gas trains suitable to RS/P BLU burners only.

HPRT - CB - MBC - VGD - DMV SERIES

Accessories

Springs for pressure regulators



Accessories springs are available for varying pressure range of the regulator-stabilizer included in the regulating/reducing unit or in MBC train.

In the following table, the springs are listed with their application range.

	SPRING	PORT	OUTLET PRESSURE (mbar)	CODE
CB/DMV 512	red	Rp 1"1/2	25÷55	3010131
CB/DMV 512	yellow	Rp 1"1/2	30÷70	-
CB/DMV 512	black	Rp 1"1/2	60÷110	3010157
CB/DMV 512	pink	Rp 1"1/2	90÷150	3090486
CB/DMV 520-525	red	Rp 2"	25÷55	3010132
CB/DMV 520-525	yellow	Rp 2"	30÷70	20026575
CB/DMV 520-525	black	Rp 2"	60÷110	3010158
CB/DMV 520-525	pink	Rp 2"	90÷150	3090487
CB/DMV 5065-5080	red	DN 65/80	25÷55	3010133
CB/DMV 5065-5080	yellow	DN 65/80	30÷70	20026575
CB/DMV 5065-5080	black	DN 65/80	60÷110	3010135
CB/DMV 5065-5080	pink	DN 65/80	100÷150	3090456
CB/DMV 5065-5080	grey	DN 65/80	140÷200	3090992
CB/DMV 50100	red	DN 100	25÷55	3010134
CB/DMV 50100	yellow	DN 100	30÷70	-
CB/DMV 50100	black	DN 100	60÷110	3010136
CB/DMV 50100	pink	DN 100	100÷150	3090489
CB/DMV 50100	grey	DN 100	140÷200	3092174
CB/DMV 50125	red	DN 125	25÷55	3010315
CB/DMV 50125	yellow	DN 125	30÷70	3010316
CB/DMV 50125	black	DN 125	60÷110	3010317
CB/DMV 50125	pink	DN 125	100÷150	3010318
MBC series	neutral	DN 68÷100	0÷20	3010381
MBC series	red	DN 68÷100	20÷40	3010382
MBC series	black	DN 68÷100	40÷80	3010383
MBC series	green	DN 68÷100	80÷150	3010384

Accessories

Connection adapters

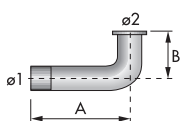
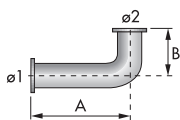

In some cases, an adapter must be fitted between the gas train and the burner, when the diameter of the gas train is different from the set diameter of the burner. Below the available adapters that can be fitted are listed.

TYPE	$\phi 1$	$\phi 2$	A	B	CODE
▶ L 65/80 - 320	DN 65	DN 80	320	174	3000831
▶ L 65/65 - 320	DN 65	DN 65	320	129	20025934
▶ L 80/80 - 320	DN 80	DN 80	320	174	3000832
▶ L 80/65 - 400	DN 80	DN 65	400	174	3010352
▶ L 100/80 - 320	DN 100	DN 80	320	174	3010127
▶ L 2"/80	2"	DN 80	540	174	3010128
▶ L 100/100	DN 100	DN 100	320	174	3090680
▶ L125/100 - 320	DN 125	DN 100	320	174	3090679
▶ L 125/80 - 320	DN 125	DN 80	320	174	3090940
▶ L 100/65	DN 100	DN 65	320	174	3010353

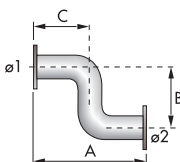

TYPE	$\phi 1$	$\phi 2$	A	B	C	CODE
▶ I 65/80 - 320	DN 65	DN 80	400	-	-	3010221
▶ I 80/80 - 320	DN 80	DN 80	400	-	-	3010222
▶ I 100/80 - 320	DN 100	DN 80	400	-	-	3010223
▶ I 125/80 - 320	DN 125	DN 80	320	-	-	3010224
▶ I 125/100 - 320	DN 125	DN 100	320	-	-	3091093
▶ Z 65/80 - 400/480/225	DN 65	DN 80	400	480	225	3010225
▶ Z 80/80 - 400/480/225	DN 80	DN 80	400	480	225	3010226
▶ Z 100/80 - 400/480/225	DN 100	DN 80	400	480	225	3010227
▶ Z 125/80 - 500/480/300	DN 125	DN 80	500	480	300	3010228

Manual valves



Ball shut-off manual valves are available in different sizes and listed in the following table.

MODEL	MAX OPERATING PRESSURE (bar)	PORT	CODE
▶ GBV 1/2"	5	1/2"	-
▶ GBV 3/4"	5	3/4"	3090097
▶ GBV 1"	5	1"	3090967
▶ GBV 1 1/2"	5	1 1/2"	3090143
▶ GBV 2"	5	2"	3090968
▶ GBV DN65	16	DN65	3090947
▶ GBV DN80	16	DN80	3090969
▶ GBV DN100	16	DN100	3090962
▶ GBV DN125	16	DN125	3091065
▶ GBV DN150	16	DN150	-

HPRT - CB - MBC - VGD - DMV SERIES

Accessories

Anti-vibrating joints

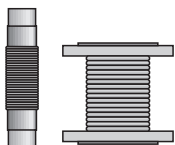

Anti-vibrating joints to damp vibrations and facilitate application of the gas train to the gas distribution line are available in different sizes listed in the table below.

TYPE	PORT SIZE	INLET MAX PRESSURE (mbar)	CODE
▶ GA 20	3/4"	500	3891033
▶ GA 25	1"	500	3891034
▶ GA 40	1"1/2	500	3891043
▶ GA 50	2"	500	3891053
▶ GAF 65	DN65	500	3891013
▶ GAF 80	DN80	500	3891003
▶ GAF 100	DN100	500	3891023
▶ GAF 125	DN125	500	3091092

Filters

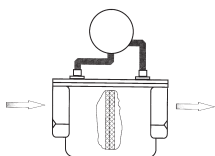

A series of gas filters of different sizes are available and listed in the following table.

TYPE	PORT IN/OUT	INLET MAX PRESSURE (bar)	CODE
▶ GF515/1	1"1/2	0,5	3012198
▶ GF520/1	2"	0,5	3012199
▶ GF40065/3	DN 65	4	3012200
▶ GF40080/3	DN 80	4	3012201
▶ GF40100/3	DN 100	4	3012202
▶ GF40125	DN 125	4	3013141

Pressure regulators

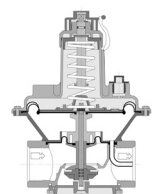

A series of pressure regulators of different sizes are available and listed in the following table.

TYPE	PORT IN/OUT	INLET MAX PRESSURE (bar)	CODE
▶ FRS 515	1"1/2	0,5	3012203
▶ FRS 520	2"	0,5	3012204
▶ FRS 5065	DN 65	0,5	3012205
▶ FRS 5080	DN 80	0,5	3012206
▶ FRS 5100	DN 100	0,5	3012207
▶ FRS 5125	DN 125	0,5	-

Accessories

Pressure gauge kit + push-button cock



A kit composed from a pressure gauge and a push-button cock for measuring gas pressure is available in different sizes following the table.

MODEL	MAX PRESSURE (mbar)	CODE
▶ NGPG 1	60	3090062
▶ NGPG 2	160	3091805
▶ NGPG 3	300	3091491
▶ NGPG 4	500	3090099
▶ NGPG 5	1000	-
▶ NGPG 6	2000	-
▶ NGPG 7	3000	-
▶ NGPG 8	4000	-

Gas pressure switch for seal control installed on the control panel



A gas pressure switch is available as seal control accessory to be installed on the control panel.

MODEL	SETTING RANGE ΔP (mbar)	CODE
▶ GW 1500	300 ÷ 1500	-
▶ GW 6000	1000 ÷ 6000	-

Seal control kit



To test the valve seals on the gas train, a special "seal control kit" is available. The valve seal control device is compulsory (EN 676) on gas trains to burners with a maximum output over 1200 kW. The seal control is type VPS 504.

GAS TRAIN	KIT CODE	
	for 50 Hz operation	for 60 Hz operation
▶ MBC/1 type	3010123	20168805
▶ CB/1 type	3010123	20168805
▶ DMV/1 type	3010123	20168805
▶ VGD type	3010123	20168805

INDUSTRIAL FANS SERIES

In order to obtain a complete Industrial Combustion System, RIELLO is able to offer various components to be matched with the Combustion Heads of DB and ER series, such as the Centrifugal Air Fans.

The fans allow to supply the air flow to the combustion head through the adduction channel, with the appropriate technical features required from the application.

The air delivery processed from the fan is in a correct proportion to the fuel in order to guarantee the required burner output with a safe operation.

The use of a separate air fan allows:

- The matching with high boiler combustion pressure.
- The working with pre-heated combustion air to reach a higher system efficiency.
- The reduction or the elimination of fan noise on boiler room.

All the fan models are pre-assembled and tested in factory, conforming to the reference standards, so to permit the maximum easiness of installation.

In Riello' Application Engineering department a dedicated team works to perform application matching and burner integration, optimizing performance to help our Customers achieving the competitive advantage they need.

We can offer a great support in terms of burner application consulting, analysis for product engineering, job development, integrated system proposals and assistance for international standards compliance.

Training, start-up, commissioning and after-sale assistance are also performed by headquarter expert engineers.

For more information about product codes, please contact Riello Burners Commercial and Technical Department.

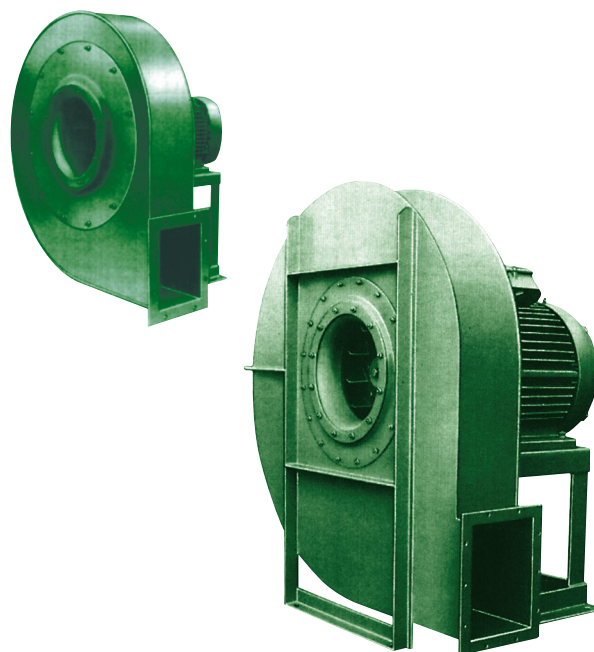

QE SERIES

In order to obtain a complete Industrial Combustion System, RIELLO is able to offer various components to be matched with the Combustion Heads of DB and ER series, such as the Control Panels.

Burner control panels are available in different structural versions, such as wall-mounted and desk type (on request). The automatic control system makes the logical integration of whole combustion system.

The customisation of this logic is carried out with the different type of combustion process and in compliance with the main safety norms.

Basic operation can be increased by the addition of more sophisticated control systems such as continuous regulation of combustion (oxygen trim), fan speed control (with inverter), electronic cam and others.

The standard control panels are designed and realized according to the norm EN 60439-1. They are suitable for indoor application (IP 54), on request, suitable for outdoor applications.

In Riello' Application Engineering department a dedicated team works to perform application matching and burner integration, optimizing performance to help our Customers achieving the competitive advantage they need.

We can offer a great support in terms of burner application consulting, analysis for product engineering, job development, integrated system proposals and assistance for international standards compliance.

Training, start-up, commissioning and after-sale assistance are also performed by headquarter expert engineers.

For more information about product codes, please contact Riello Burners Commercial and Technical Department.



QE...PM	Natural Gas
QE...PG	Light Oil
QE...PN	Heavy Oil
QE...PGM	Natural Gas and Light Oil
QE...PNM	Natural Gas and heavy Oil

Request for information

If you did not find the product for your application in this catalogue, please fill in the following form and send it to RIELLO BURNERS APPLICATION ENGINEERING DEPT. (fax +39 0442 630 375 - application.engineering@rielloburners.com)

Customer:		Contact person:		Riello Project Ref.:	
Boiler model:		Manufacturer:		Year:	
<input type="checkbox"/> Hot water	<input type="checkbox"/> Superheated water	<input type="checkbox"/> Thermal oil	<input type="checkbox"/> _____		
<input type="checkbox"/> High pressure steam	<input type="checkbox"/> Low pressure steam	<input type="checkbox"/> Superheated steam			
Max working pressure <input type="text"/> bar		Max working temperature <input type="text"/> °C		Steam <input type="text"/> ton/h	
System design		<input type="checkbox"/> Firetube	<input type="checkbox"/> 3-pass	<input type="checkbox"/> Heat recovery	<input type="checkbox"/> Twin chamber/Twin burner
		<input type="checkbox"/> Watertube	<input type="checkbox"/> Reversed flame	<input type="checkbox"/> Single chamber/Twin burner	
Type of Process application					
Thermal power					
Boiler nominal output		<input type="text"/> kW	<input type="text"/> kcal/h	Efficiency <input type="text"/> %	
Burner nominal output		<input type="text"/> kW	<input type="text"/> kcal/h		
Combustion chamber data					
Combustion chamber resistance		<input type="text"/> mbar	<input type="text"/> mm W.C.	<input type="text"/> W.C.	
Length	<input type="text"/> mm	High	<input type="text"/> mm		
Diameter	<input type="text"/> mm	Width	<input type="text"/> mm	Min burner head projection <input type="text"/> mm	
Fuel					
<input type="checkbox"/> Natural gas	<input type="checkbox"/> LPG	<input type="checkbox"/> Town gas	<input type="checkbox"/> _____	<input type="checkbox"/> _____	
<input type="checkbox"/> Light oil	<input type="checkbox"/> Heavy oil	<input type="checkbox"/> Kerosene	<input type="checkbox"/> _____		
Gas supply					
Net calorific value		<input type="text"/> kWh/Nmc	<input type="text"/> kcal/Nmc		
Gas supply pressure		<input type="text"/> mbar	<input type="text"/> Bar		
Gas train					
<input type="checkbox"/> Regulating gas train		<input type="checkbox"/> Safety gas train		<input type="checkbox"/> Leakage control	
Oil supply					
Viscosity:		<input type="checkbox"/> 6 cSt at 20°C	<input type="checkbox"/> 3°E at 50°C	<input type="checkbox"/> 20°E at 50°C	<input type="checkbox"/> 50°E at 50°C
Lower calorific value: ...		<input type="text"/>	kWh/kg <input type="text"/>	kcal/kg <input type="text"/>	
Burner site installation					
Country		<input type="text"/>	Town		<input type="text"/>
Altitude <input type="text"/> m a.s.l.		<input type="checkbox"/> Indoor	<input type="checkbox"/> Outdoor	Temperature <input type="text"/> °C	
Electrical data (Power voltage / control voltage / frequency)					
<input type="checkbox"/> 400/230/50	<input type="checkbox"/> 380/220/60	<input type="checkbox"/> 210/120/60	<input type="checkbox"/> 440/220/60	<input type="checkbox"/> 230/230/50	<input type="checkbox"/> other ____ / ____ / ____
Burner control options					
<input type="checkbox"/> Mechanical cam		<input type="checkbox"/> O ₂ only Analysis		<input type="checkbox"/> Fan speed control (VSD)	
<input type="checkbox"/> Electronic cam		<input type="checkbox"/> O ₂ Trim			
Burner pumping unit					
<input type="checkbox"/> Single pump		<input type="checkbox"/> Single filter	Oil preheater		
<input type="checkbox"/> Double pump		<input type="checkbox"/> Double filter	<input type="checkbox"/> Electrical		
			<input type="checkbox"/> Steam + Electrical		
Approval/compliance with:					
<input type="checkbox"/> European Standards EN 267, EN 676		<input type="checkbox"/> North American Standards UL 296, UL 795		<input type="checkbox"/> _____	
Other requirements					
Date					
Signature					

Sales & Service Network

WEST EUROPE

COUNTRY	COMPANY	REFERENCES FOR CONTACT
ALBANIA	Name: Klevis&Rjello Address: Rruga Don Bosko, Pallati 139/3 City: Tirane	Office Phone: 00355 683032965 e-mail: shehudenis@yahoo.it
AUSTRIA	Name: Eibisberger Gerhard Address: Südbahnstraße 34 - 36 City: A- 8700 Leoben	Office Phone: +43 0 3842/44749 Office Fax: +43 0 3842/44749-1 e-mail: info@riello.at website: www.riello.at
BELGIUM	Name: Riello S.p.A. Address: Via Ing. Pilade Riello, no. 7 City: I-37045 Legnago (VERONA)	Office Phone: 0039 0442 630111 Office Fax: 0039 0442 21980 e-mail: info@riello.com
BOSNIA	Name: Vokel D.O.O. Address: Vinjani B.B. City: 88240 Posusje	Office Phone: 0039 739693 Office Fax: 0039 739693199 e-mail: vokel@vokel.com
CROATIA	Name: Riello Address: Gaje Alage 1 City: 10000 Zagreb	Office Phone: 00385914578808 website: www.riello.hr
CYPRUS	Name: Royal Engineering Co. Ltd. Address: 1, Prodicou Str. P.O. Box 20689 City: 1662 Nicosia	Office Phone: +357-2-344985 / 347782 Office Fax: +357 - 2 - 348436 Mobile Phone: +35-09-657192 e-mail: styleng@cytanet.com.cy
DENMARK	Name: Milton Megatherm A/S Address: Formervangen 12-16 City: DK-2600 Glostrup	Office Phone: +45 46970000 Office Fax: +45 46970001 e-mail: info@miltonmegatherm.dk www.miltonmegatherm.dk

WEST EUROPE

COUNTRY	COMPANY	REFERENCES FOR CONTACT
DENMARK	Name: V. Hansen ApS Address: Tarupvej 57 City: DK 5210 Odense NV	Office Phone: +45 66156151 e-mail: info@vh-as.dk website: www.vh-as.dk
FRANCE	Name: Riello France Brûleurs France Address: Espace Vinci - Balthus 3A - 24/28 Avenue Graham Bell City: 77600 Bussy Saint Georges	Office Phone: +33 1 80 66 99 66 Office Fax: +33 1 80 66 99 55 e-mail: contact@riello.fr website: www.riello.com www.interventions.riello.fr
GERMANY	Name: Riello S.p.A. Zweigniederlassung Deutschland Address: Josef-Baumann-Str. 19a City: 44805 Bochum	Office Phone: +49 234 8901412 Office Fax: +49 234 8901419 e-mail: info@rielloburners.de
GREECE	Name: Caloria S.A. Address: 57 Ifestou str. City: 19400 Koropi - Athens	Office Phone: 0030-210-6628068/69/70/71/72/73 Office Fax: 0030-210-6623784 Mobile Phone: 0030-6944841974 e-mail: info@caloria.gr
HOLLAND	Name: Condair BV Address: Gyroscoopweg 21 City: 1042 AC Amsterdam	Office Phone: +31 020-7058200 Office Fax: +31 020 7058201 e-mail: info@condair.nl www.condair.nl
	Name: Vitotherm B.V. Address: Overgauwseweg 8 City: 2641 NE Pijnacker	Office Phone: +31 15 3694757 website: www.vitotherm.nl e-mail: info@vitotherm.nl
ITALY	Name: Riello S.p.A. Address: Via Ing. Pilade Riello, 7 City: 37045 Legnago (VR)	Office Phone: +39 0442 630111 Office Fax: +39 0442 631527 e-mail: assistenza@riello.it website: www.riello.it
MALTA	Name: Anthony Falzon Energy Projects Address: 12, Triq il-Parrocca City: St. Venera HMR 18	Office Phone: +356 21470265 Office Fax: +356 21470264 e-mail: info@energyprojectsmalta.com

WEST EUROPE

COUNTRY	COMPANY	REFERENCES FOR CONTACT
NORWAY	Name: VV Gruppen AS avd. WVPARTS Address: Larkollveien 10 City: N-1570 Dilling	Office Phone: +47 69 26 46 70 e-mail: post@vvparts.no website: www.vvparts.no
PORTUGAL	Name: Euroma 21, Lda. Address: Tv. Sá e Melo, 161 - Fracção LB City: 4470-116 Maia	Office Phone: +351 229421058 Office Fax: +351 229489456 e-mail: euroma21@gmail.com website: www.riello.com
	Name: Alfa Combustion S.L. Address: Passatge dels Til.lers,13 City: 08390 Montgat (Spain)	Office Phone: +34 93 2427852 e-mail: alfa@alfacombustion.com website: www.alfacombustion.com www.riello.com
	Name: Sanitop Material Sanitario, Lda Address: Zona Industrial 2º Fase, Apartado 538 City: 4935-232 Neiva - Viano do Castelo	Office Phone: +351 258350010 Office Fax: +351 258350011 e-mail: sanitop@sanitop.pt website: www.riello.com
SERBIA	Name: Doming D.O.O. Address: Vodovodska 164E City: 11250 Belgrado	Office Phone: 0038 1112589666 Office Fax: 0038 1112577161 website: www.doming.rs
SLOVENIA	Name: Riello Address: Gaje Alage 1 City: 10000 Zagreb	Office Phone: 0038 5914578808 website: www.riello.si
SPAIN	Name: Alfa Combustion S.L. Address: Passatge dels Til.lers,13 City: 08390 Montgat (Spain)	Office Phone: +34 93 2427852 e-mail: alfa@alfacombustion.com website: www.alfacombustion.com
SWITZERLAND	Name: Riello Suisse S.A. Address: Via Industria City: CH-6814 Lamone	Office Phone: +41/91/6045022 Office Fax: +41/91/6045024 Mobile Phone: +41/79/2070551 e-mail: guenther.bezler@riello.ch

WEST EUROPE

COUNTRY	COMPANY	REFERENCES FOR CONTACT
SWEDEN	Name: Milton Sverige AB Address: Lastgatan 13 City: 254 64 Helsingborg	Office Phone: +46 042252840 Office Fax: +46 042158621 e-mail: info@milton.se website: www.milton.se
	Name: V. Hansen ApS Address: Tarupvej 57 City: DK 5210 Odense NV	Office Phone: +45 66156151 e-mail: info@vh-as.dk website: www.vh-as.dk
UK	Name: Riello Ltd. Address: The Ermine Centre Ermine Business Park City: Huntingdon Cambridgeshire PE29 6WX	Office Phone: +44 1480432144 Office Fax: +44 1480432191 e-mail: info@rielloburners.co.uk

EAST EUROPE

COUNTRY	COMPANY	REFERENCES FOR CONTACT
BULGARIA	Name: Caloria Ltd. Address: 202 Street, no. 8 City: 1220 Sofia	Office Phone: +359 2 83111-30/33 Office Fax: +359 2 83111-34 Mobile Phone: +359 89845150 +395 888233284 e-mail: riello@techno-link.com website: www.caloria.bg
CZECH REPUBLIC	Name: RUG Riello Urzadzenia Grzewcze S.A. - Subsidiary Wroclaw Address: UL. PÓLNOČNA 15-19 City: 54-105 Wroclaw (Polska)	Office Phone: +48 71 326 53 4 - 95 e-mail: sales@rielloburners.pl serwis@rielloburners.pl
ESTONIA	Name: RUG Riello Urzadzenia Grzewcze S.A. - Subsidiary Wroclaw Address: UL. PÓLNOČNA 15-19 City: 54-105 Wroclaw (Polska)	Office Phone: +48 71 326 53 4 - 95 e-mail: sales@rielloburners.pl serwis@rielloburners.pl

EAST EUROPE

COUNTRY	COMPANY	REFERENCES FOR CONTACT
HUNGARY	Name: Riello S.p.A. Magyarországi Fiòktelepe Address: Lomb Utca 37-39 City: H-1139 Budapest	Office Phone: +36 1 3399069 Office Fax: +36 1 3200578 e-mail: info@riello.hu
LATVIA	Name: RUG Riello Urzadzenia Grzewcze S.A. - Subsidiary Wroclaw Address: UL. PÓLNOCNA 15-19 City: 54-105 Wroclaw (Polska)	Office Phone: +48 71 326 53 4 - 95 e-mail: sales@rielloburners.pl serwis@rielloburners.pl
LITHUANIA	Name: RUG Riello Urzadzenia Grzewcze S.A. - Subsidiary Wroclaw Address: UL. PÓLNOCNA 15-19 City: 54-105 Wroclaw (Polska)	Office Phone: +48 71 326 53 4 - 95 e-mail: sales@rielloburners.pl serwis@rielloburners.pl
POLAND	Name: RUG Riello Urzadzenia Grzewcze S.A. - Subsidiary Wroclaw Address: UL. PÓLNOCNA 15-19 City: 54-105 Wroclaw (Polska)	Office Phone: +48 71 326 53 4 - 95 e-mail: sales@rielloburners.pl serwis@rielloburners.pl
ROMANIA	Name: Riello RO S.r.l. Address: Str. Copilului Nr. 20 Sector 1 City: 012178 Bucuresti	Office Phone: +40 21 2246648 Office Fax: +40 21 2029287 e-mail: office@riello.ro
SLOVAK REPUBLIC	Name: RUG Riello Urzadzenia Grzewcze S.A. - Subsidiary Wroclaw Address: UL. PÓLNOCNA 15-19 City: 54-105 Wroclaw (Polska)	Office Phone: +48 71 326 53 4 - 95 e-mail: sales@rielloburners.pl serwis@rielloburners.pl

MIDDLE EAST AND AFRICA

COUNTRY	COMPANY	REFERENCES FOR CONTACT
EGYPT	Name: Mohamed Ahmed Omer Address: 11 Darb Shaikh Faraq St. City: Block Ela - Cairo	Office Phone: +2 02 5762898-5797176 Office Fax: +2 02 5779503 e-mail: a-omar@link.net
JORDAN	Name: Matco - Mazzawi Trading Co. Address: P.O. Box 9151 City: Amman 11191	Office Phone: +962 6 5513462 - 5513463 Office Fax: +962 6 5524127 e-mail: adel@mazzawitrading.com
	Name: United Pioneering Business Address: 309 Wasfi Tal Street Khalda Amman Jordan City: Amman	Office Phone: +962 6-552-6850 Office Fax: +962 6-552-6859 e-mail: info@upb.com.jo info@upbgroup.com website: www.upbgroup.com
LEBANON	Name: Hage Group Address: Rue Monot, Imm. Tabet 11-4991 City: 9312 Beirouth	Office Phone: +961 1 329209 Office Fax: +961 1 329209 Mobile Phone: +961 3 618558 e-mail: rony@hagegroup.com
MOROCCO	Name: Aqua Flamme Address: Rue de l'Aisne Belvedere 22-24 City: Casablanca	Office Phone: +212 22 305 350 Office Fax: +212 22 305 289 e-mail: aquaflamme@aquaflamme.ma
	Name: VM DISTRIBUTION Address: Route de Rabat B.P. 2578 Aïn Sebaâ City: Casablanca	Office Phone: +212 522 677 450 e-mail: mailto:distrib@vmdistribution.ma website: www.vmdistribution.ma
NAMIBIA	Name: Rentech Address: Rentech Building, no. 5, 12th street, Industrial Area City: Walvis Bay	Office Phone: +264 64 204327 Office Fax: +264 64 204328 e-mail: info@rentech.bz website: www.rentech.bz

MIDDLE EAST AND AFRICA

COUNTRY	COMPANY	REFERENCES FOR CONTACT
SOUTH AFRICA	Name: Combustion Technology (Pty) Ltd. Postal Address: P.O. BOX 30047, Tokai, 7966, Cape Town Premises Address: Unit 28E, 60 White Road, Retreat, 7945, Cape Town	Office Phone: +27 (21) 7153171 Office Fax: +27 (21) 7156297 Mobile Phone: +27 82 568 4012 e-mail: grant@rielloburners.co.za
TUNISIA	Name: Sotucep S.A. Address: 8, Rue Abou El Hassen Gabsi City: Citè El Khadra - 1003 Tunis	Office Phone: +216 1 772506 Office Fax: +216 1 770476 Mobile Phone: +21609342132 e-mail: khouja.samir@sotucep.com
TURKEY	Name: e-Gaz Malzemeleri Mühendislik Ltd. Şti. Address: Perpa Ticaret Merkezi B Blok Kat: 2 No. 58 City: 34384 Şişli / İstanbul	Office Phone: +90 (0) 212 3203400-02 Office Fax: +90 (0) 212 3207925 e-mail: info@e-gaz.com.tr www.e-gaz.com.tr www.riellobrulor.com.tr
UNITED ARAB EMIRATES	Name: Alitaliya Trading Est. Address: P.O. Box 28095 City: Sharjah	Office Phone: +971 6 5671265 Office Fax: +971 6 5670260 e-mail: mail@alitaliya.com

FAR EAST AND OCEANIA

COUNTRY	COMPANY	REFERENCES FOR CONTACT
AUSTRALIA	Name: Accutherm Address: Unit 1/5 Samantha Court City: Knoxfield 3180 Victoria	Office Phone: +61 3 97636335 Office Fax: +61 3 97638003 e-mail: sales@accutherm.com.au
	Name: System Control Engineering PTY. LTD. Address: 5 Alfred Street, Blackburn, Victoria 3130 City: Melbourne	Office Phone: +61 3 9877 3211 Office Fax: +61 3 9878 5337 e-mails: scott.rimes@systemcontrol.com.au brian.walton@systemcontrol.com.au website: www.systemcontrol.com.au
CHINA	Name: Riello Heating Equipment (Shanghai) Co., Ltd, Beijing Branch Address: Rm. 606, Wanhao Office Building A, No. 7 jianguomen South Avenue Dongcheng District City: 100005 Beijing	Office Phone: +86 10 6563 0131 Office Fax: +86 10 6566 2772 e-mail: beijing.office@riello.com
INDIA	Name: Suntec Energy Systems Address: Plot no. 56, Phase-1 GIDC, Naroda, City: 382330 Ahmedabad	Office Phone: +91 79 22805529-30-31 Office Fax: +91 79 22805532 e-mail: anita@suntecenergy.in
INDONESIA	Name: PT. Unitek Standarindo Engineering Address: Jl. Pangeran Jayakarta 44/29 City: 10730 Jakarta	Office Phone: +62 21 6289456 - 6264806 Office Fax: +62 21 6264807 e-mail: unitek@unitek.co.id
JAPAN	Name: SAN-E Inc. Address: Code 230-0003, 2-Chome, Shitte Shitte 2-1-53, Tsuruni-ku City: Yokohama	Office Phone: +81 45-575-8097 Office Fax: +81 45-575-8099 e-mail: info@san-eee.com website: https://www.san-eee.com
KOREA	Name: Chungwoo Gnt. Co. Ltd. Address: 23, 58 Beon-Gil, MTV25-Ro Siheung-Si City: Gyeonggi-Do	Office Phone: +82 31 4972041 Office Fax: +82 31 4972048 e-mail: cwgnt@naver.com website: http://www.cwgnt.co.kr

FAR EAST AND OCEANIA

COUNTRY	COMPANY	REFERENCES FOR CONTACT
MALAYSIA	Name: Unimech Eng. Sdn Bhd. Address: No. 4934, Jalan Chain Ferry City: 12100 Butterworth, Penang	Office Phone: +60 4 33288821/2/3 Office Fax: +60 4 3325491 e-mail: lk.wong@unimechgroup.com
NEW ZEALAND	Name: System Control Engineering NZ Ltd. Address: 182 Station Road, Penrose, 1006 City: Auckland	Office Phone: + 64 9 636 1401 Office Fax: + 64 9 636 1525 Mobile: 0275 939 684 e-mail: sales@systemcontrol.co.nz website: www.systemcontrol.co.nz
PHILIPPINES	Name: Riello S.p.A. Rep. Off. Address: 10, Winstedt Road #03-11 City: 227977 Singapore	Office Phone: +65 63415580 Office Fax: +65 63980314 e-mail: info@riello.com.sg
SRI LANKA	Name: Ess Kaye Enterprise Address: 6/1B, Tyre Corporation Road, Dalugama City: Kelaniya	Office phone: +94 11 4815918 Office fax: +94 11 5511351 e-mail: sksiva@sol.lk
TAIWAN	Name: Ching Ye Co. Ltd. Address: 8F-11, No.16, Lane. 609, Sec. 5, Chung Hsin Rd., Sanchung Dist. City: New Taipei City 24159	Office Phone: +886 2 29990456 Office Fax: +886 2 29990455 e-mail: info@chingye.com.tw website: www.ching-ye.com.tw
THAILAND	Name: R.L. Burner (Thailand) Co., Ltd. Address: 24, 26 Soi Chan 18/7 Yak 3 Thungwatdon, Sathorn City: 10120 Bangkok	Office Phone: +66 2 6732772 Office Fax: +66 2 6731881 e-mail: rielloth@truemail.co.th
VIETNAM	Name: Dinh Hai Equipment Co. Ltd.-DHE Address: 1C Street No 10, Tan Binh Industrial Park City: Ho Chi Minh	Office Phone: +84 8 38155195 Office Fax: + 84 8 38155196 Mobile Phone: +84 90701 289 e-mail: dinhhai@hcm.vnn.vn
	Name: Dinh Hai Equipment Co. Ltd.-DHE Address: Floor 8th, No. 804, Tower 562, Nguyen Van Cu Street, Long Bien Dist., City: Hanoi	Office Phone: +84 8 043212790 Mobile Phone: +84 911412884 e-mail: hanoi@dinhhai.com

AMERICA

COUNTRY	COMPANY	REFERENCES FOR CONTACT
ARGENTINA	Name: EQA S.A.I.C. Address: 26 de Abril 3836 City: 1714 Ituzaingo	Office Phone: +54 11 44819950 y rotativas Office Fax: +54 11 44819288 e-mail: eqa@eqa.com.ar website: www.eqa.com.ar
BOLIVIA	Name: EQA S.A.I.C. Address: 26 de Abril 3836 City: 1714 Ituzaingo	Office Phone: +54 11 44819950 y rotativas Office Fax: +54 11 44819288 e-mail: eqa@eqa.com.ar website: www.eqa.com.ar
BRAZIL	Name: Auto-Ferr Ind. e Com. de Queimadores Ltda. Address: Av. Álvaro Guimarães, 322 09890-001 Bairro Planalto City: São Bernardo do Campo	Office Phone: +55 11 4341-3020 Office Fax: +55 11 4341-3021 e-mail: autoferr@riello.com.br website: www.riello.com.br
CANADA	Name: Riello Burners North America Address: 2165 Meadowpine Blvd. City: L5N 6H6 Mississauga (Ontario)	Office Phone: +1-800-4-RIELLO +1-800-474-3556 Office Fax: +1-866-2-RIELLO e-mail: info@rbna.com
CHILE	Name: Commercial Anwo Ltda Av. Address: Eduardo Frei Montalva17.001 City: Colina Santiago	Office Phone: +56 2 29890000 Office Fax: +56 2 2730404 website: www.anwo.cl
COLOMBIA	Name: Equisol Commercial Division of INDISA S.A. Address: Carrera. 75 no. 48A-07 City: 55812 Medellin	Office Phone: +57 4 4446169 Office Fax: +57 4 2308388 e-mail: equisol@equisol.com.co website: www.equisol.com.co
ECUADOR	Name: Calderas y Servicios del Ecuador Calser S.A. Address: Juan Barrezueta N77-313 Y Juan De Selis City: Quito	Office Phone: +593 2 2479992 +593 2 2480102 +593 2 2473862 e-mail: ventasquito@calser.com.ec calserecuador@yahoo.com website: www.calser.com.ec

AMERICA

COUNTRY	COMPANY	REFERENCES FOR CONTACT
GUATEMALA	Name: Comercial Fema, S. A. Address: 6ta. Avenida 13-53 Zona 9	Office Phone: +502 2361-2825 +502 2361-9039 +502 2361-5337 +502 2360-5899 e-mail: info@comercialfema.com website: www.comercialfema.com
MEXICO	Name: Thermal Combustion S. de R.L. de C.V. Address: Calle 37 poniente 2520-B Col. Benito Juárez City: C.P. 72410 Puebla	Office Phone: +52 222 279-6643 (Puebla) e-mail: info@thermalcombustion.com website: www.thermalcombustion.com
	Name: Controles y Quemadores de Mexico, S.A. de C.V. Address: Blvd. Hermanos Serdan, 41 Col. Amor City: Puebla	Office Phone: +52 22 480817 Office Fax: +52 22 480817 e-mail: info@cqmexico.com.mx website: www.cqmexico.com.mx
PANAMA	Name: Servipan S.A. Address: Calle Principal Altos de Bethania 3C - Apartado 6 City: 2680 El Dorado Panama	Office Phone: +507 2600748 Office Fax: +507 2606342 e-mail: servipa@sinfo.net
PARAGUAY	Name: EQA S.A.I.C. Address: 26 de Abril 3836 City: 1714 Ituzaingo	Office Phone: +54 11 44819950 y rotativas Office Fax: +54 11 44819288 e-mail: eqa@eqa.com.ar website: www.eqa.com.ar
PERÙ	Name: RACINGAS EIRL Address office: Jr San Pedro 845 of 206 Surquillo City: Surquillo - Perú	Office Phone: +511 424-2935 +511 241-6529 Cel: +511 985241888 NEXTEL: 99-421*9647 94-601*0913 e-mail: mhuapalla@racingas.com.pe nbravoracingas.com.pe website: www.racingas.com.pe

AMERICA

COUNTRY	COMPANY	REFERENCES FOR CONTACT
URUGUAY	Name: Tecnosolar S.A. Address: Calle Paraguay 1968/76 City: 11800 Montevideo	Office Phone: +59829240738-42 Office Fax: +59829248423 e-mail: info@tecnosolar.com.uy website: www.tecnosolar.com.uy
	Name: CIR Acondicionamiento Termico Grupo CIR Address: Bvar. Artigas 2879 City: Montevideo - Uruguay	Office Phone: +598 2200 7821 website: www.ciruy.com
USA	Name: Riello Burners North America Address: 35 Pond Park Road City: 02043 Hingham (Massachusetts)	Office Phone: +1-800-4-RIELLO +1-800-474-3556 Office Fax: +1-866-2-RIELLO e-mail: info@rbna.com
VENEZUELA	Name: Riello Venezuela Address: Calle 13, edf Yamato PB Local 6-E - La Urbina City: Caracas	Office Phone: +58 212 2416748 Office Fax: +58 414 3268480 e-mail: enricopancera@hotmail.com

Certificate

Standard **ISO 9001:2015**

Certificate No. 39 00 2281611

TÜV Rheinland Italia S.r.l. certifies:

Certificate Holder: **RIELLO S.p.A**
HQ

Via Ing. Pilade Riello, 7
37045 San Pietro di Legnago (VR)
Italy

Scope: Design, manufacture sales and service of: burners for residential heating and for commercial and industrial application; wall hung boilers and water heaters; units, floor-standing boilers and heating systems; solar collectors and solar boilers. Sales and assistance of its own brand traded products for heating; products for conditioning and cooling, products for cogeneration and trigeneration; system accessories; spare parts and accessories; moduls, solar inverter and structures for photovoltaic systems.

IAF sector: 18

Proof has been furnished by means of an audit that the requirements according to ISO 9001:2015 are fulfilled.

The due date for all future audits is 11-19.

Validity: The certificate is valid from 2016-12-11 until 2019-12-10.
First certification 1992.

2017-01-13

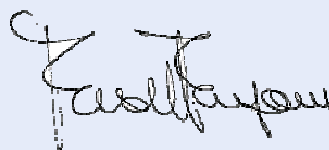

TÜV Rheinland Italia S.r.l., Via E. Mattei, 3
I - 20010 Pogliano Milanese (MI)

www.tuvitalia.com



SGQ N° 083A SGA N° 052D

Membro degli Accordi di Mutuo Riconoscimento EA, IAF e ILAC

Signatory of EA, IAF and ILAC Mutual Recognition Agreement

 **TÜVRheinland®**
Precisely Right.

RIELLO S.p.A. - 37045 Legnago (VR) - Italy
tel. +39 0442 630111 - fax +39 0442 21980
www.riello.com

Since the Company is constantly engaged in the production improvement, the aesthetic and dimensional features, the technical data, the equipment and the accessories can be changed.
This document contains confidential and proprietary information of RIELLO S.p.A. Unless authorised, this information shall not be divulged, nor duplicated in whole or in part.

RIELLO

27015813